

Project of the electronic system for automatic interpretation of the combustion engine control characteristics

Abstract: In the article a method for acquiring ignition angle maps and cylinder filling characteristics from EEC-IV control unit was described. Originally, the chosen EEC unit was controlling Ford Sierra 2.0DOHC engine. Measuring method principle was to substitute real sensors with compatible artificial electrical signals, expose EEC to them and eventually measure how EEC changes output signals values in real-time. Arranging input signals in patterns resembling typical engine working conditions allowed considering EEC response as valid for analysis. This response is a group of signals controlling such executive elements like injectors, sparking plugs, exhaust gases recirculation system and others. Specially designed embedded software of the measurement system enabled consecutive and automatic input values setting and capturing the following control decision in whole applicable range. This allowed creation of ignition angle maps and cylinder filling characteristics of the examined EEC module.

Key words: *Electronic Engine Control, educational, sensors, real-time visualization, interface*

Projekt układu elektronicznego do automatycznego odczytywania charakterystyk sterowania silnikiem spalinowym

Streszczenie: W artykule przedstawiono jedną z metod odczytania charakterystyk zapłonu i wtrysku paliwa zapisanych w jednostce sterującej EEC-IV pochodzącej z samochodu Ford Sierra 2.0DOHC EFI. Polegała ona na stworzeniu wirtualnych sensorów, realizowanych przez autorski układ elektroniczny, którego zadaniem było zadawanie na wejścia EEC sygnałów o przebiegach możliwie zbliżonych do sygnałów z czujników rzeczywistych. Odpowiednie skorelowanie ich wartości, odzwierciedlających potencjalne warunki pracy silnika, pozwoliło na traktowanie odpowiedzi EEC jako wymiernej do analizy. Odpowiedź EEC to grupa sygnałów sterujących elementami wykonawczymi takimi jak układ wtryskowy, układ zapłonowy, układ recyrkulacji spalin i inne. Oprogramowanie układu pomiarowego umożliwiło automatyczne i stopniowe zadawanie wielkości wejściowych oraz przyporządkowywanie im zmierzonych wielkości wyjściowych jednostki EEC. Dzięki temu możliwe było stworzenie map wtryskowych i zapłonowych badanego modułu sterującego.

1. Introduction

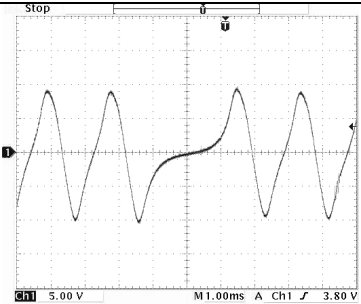
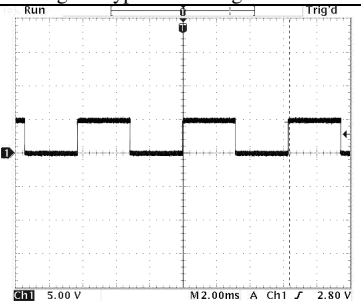
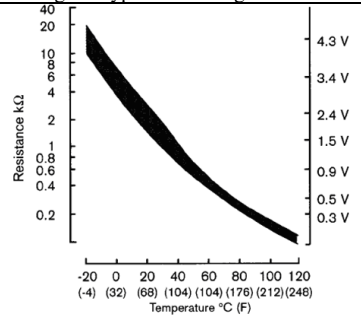
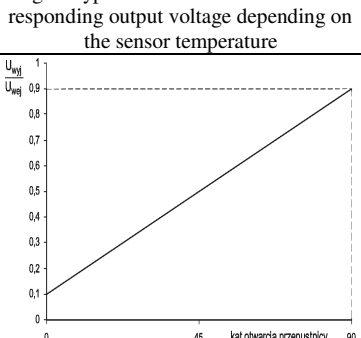
Technology of electronic engine control is a modern and extensively developed branch of motorization industry. Main reasons for it are: introducing rigorous norms concerning toxic fumes emission, minimization of fuel consumption, attempt to gain as much power as possible from a certain cubic capacity. In addition to above, trends to simplify car maintenance and automatic failures diagnosing systems should be mentioned. Currently all cars equipped with direct fuel injection engine have a dedicated type of Electronic Engine Control (EEC) unit as an integral element of whole driving system[1].

Major difficulty while electronically controlling a combustion engine is a possible sensor defect. The common way to deal with this problem is to use some default reading value or attempt to estimate the value on the basis of other sensors. The sensors can be differentiated on those which mal-

function is resulting with improper engine behavior (diminished power, irregular work) and on those, like Crankshaft Position Sensor, which failure immobilizes the engine completely. Other problem is that sensor readings could be affected by random or systematic noise. Presence of such condition, in state of dynamic adaptation functioning, can disturb control characteristics. In worst case they have to be manually reset.

This paper presents a device that is enabling to observe EEC internal characteristics. The main idea behind is to replace all of the real sensors attached to EEC unit with artificially generated signals. Their time and frequency characteristics should resemble the specifics of each physical sensor. Additionally, the simulator is attached to EEC outputs for parallel monitoring EEC response (control decision) in real-time. The device can be used in real engine diagnostic (by serving a "fake signal" instead of a temporarily disconnected sensor) or for educational purposes.

Tab. 1. Summary of major sensors present in direct fuel injection engine control systems

EEC-IV Input name	Functional description	Signal shape expected by EEC-IV	Signal properties description
Crankshaft Position (CKP) Sensor	Used to record the rate at which the crankshaft is spinning. The sensor system consists of a rotating part, typically a disc, as well as a static part, the actual sensor. Typically a Hall Effect sensor is used as the static part requiring a magnet to be mounted somewhere in the periphery of the rotating disc[2,3,4].	 <p>Fig. 1. Typical CKP signal curve</p>	Sinusoid changing its amplitude and period depending on engine RPM. For 800RPM the absolute values were in range of -10V/+10V, but for 6000RPM between -50V and +50V.
Mainfold Absolute Pressure (MAP) Sensor	Indicated data is used to calculate air density and determine the engine's air mass flow rate, which in turn determines the required fuel metering for optimum combustion[2,4].	 <p>Fig. 2. Typical MAP signal curve</p>	Square wave of 5V amplitude. Modulated by frequency, from 160Hz (which corresponds to maximal engine load) to 100Hz (engine idling).
Engine Coolant Temp. (ECT) and Intake Air Temp. (IAT) Sensor	Temperature indicators of an engine and it's environment. Used for determining cold engine start, operating temperature reach as well as overheating [2,3].	 <p>Fig.3. Typical ECT resistance and corresponding output voltage depending on the sensor temperature</p>	Almost linear voltage from 0.2V to 4.5V. The sensor is connected in series to a fixed value resistor. The ECM supplies 5V to the circuit and measures the change in voltage between the fixed value resistor and the temperature sensor.
Throttle Position (TP) Sensor	Usually a potentiometer located on the butterfly spindle so that it can directly monitor the position of the throttle valve butterfly. In fuel injected engines, in order to avoid stalling, extra fuel may be injected if the throttle is opened rapidly (mimicking the accelerator pump of carburetor systems) [2,4].	 <p>Fig. 4. Typical curve for V_{tp} / V_{ref} relationship</p>	Almost linear voltage from 0.5V to 4.5V.

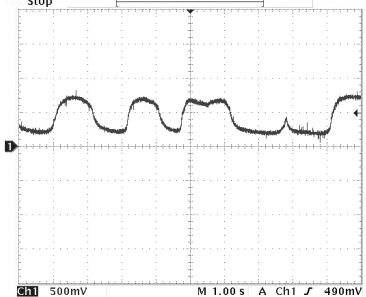
Heated Oxygen Sensor (HO ₂ S)	Used to regulate the fuel mixture in a "closed loop" operation. The result is a constant flip-flop back and forth from rich to lean which allows the catalytic converter to operate at peak efficiency while keeping the average overall fuel mixture in proper balance to minimize emissions [2,4].		Constantly changing signal between two levels: 0,2V and 0,8V.
--	--	--	---

Fig. 5. Typical HO₂S signal curve

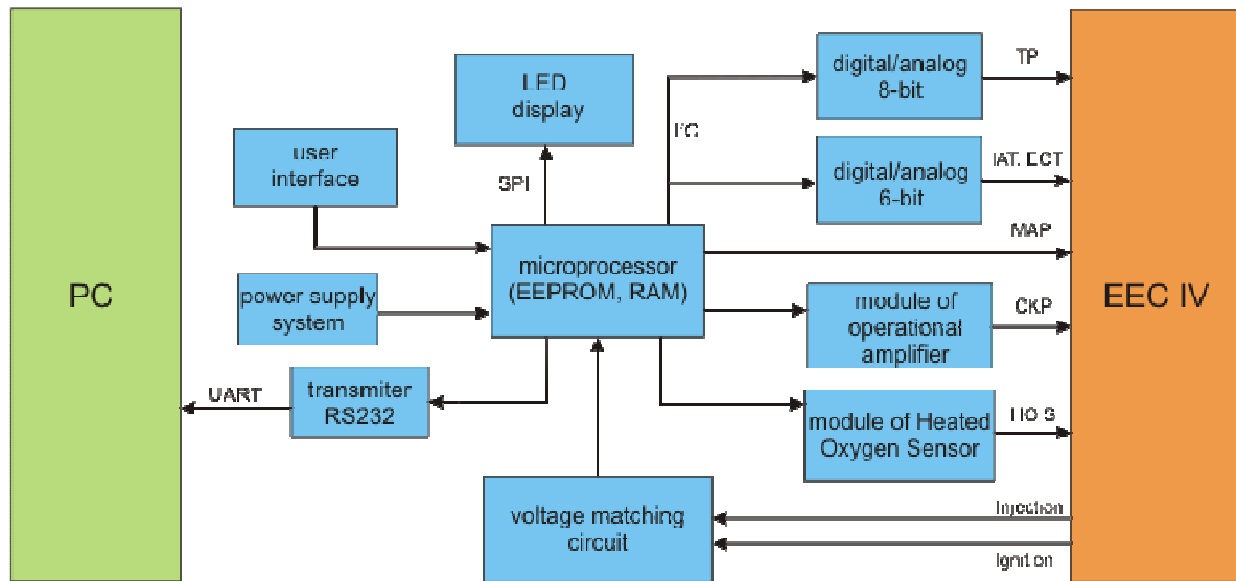


Fig. 6. Simulator functional block diagram

2. Inputs of an EEC unit

The target chosen to interface with is Ford EEC-IV unit, originally designed for Ford Sierra 2.0DOHC EFI engine. It is an example of an early design, done in late 80's, where it was mostly responsible for substituting mechanical carburetor. Still, the functions realized are not differing much from newest EEC constructions. What is more, its relative simplicity helps to predict and track EEC decisions.

There is a number of sensors that EEC-IV unit requires to monitor in order to discover engine working conditions. Below an absolute minimum set is listed. This set is sufficient enough to make EEC "think" it is mounted and working in a real car. Other inputs can be left connected to signal ground or supply voltage.

3. Simulator circuit

Core of the simulator is an 8-bit Atmel ATmega88 RISC microcontroller. Because most of the generated/measured signals have simple digital nature, there was no reason to introduce a microprocessor of a greater complexity. Due to the fact that EEC consumes about 500mA of current (at

12V) in a normal state and a need for two operational voltage levels (+5V for the micro and +12V for operational amplifiers) to power up the system, an external ATX computer power supply was used. Main sub-circuits that can be identified in the device are:

- user interface (potentiometer, buttons) and a context numerical display
- MAX517 8-bit and TDA8444P 6-bit D/A converters, instructed through I²C bus by the micro, serving an analog signal for TP, IAT and ECT
- LM324N configured as differential amplifier, powered by symmetrical -12V/+12V voltage taken from ICL7660CPA voltage inverter. Used for adjusting the micro PWM signal levels in CKP sensor module. What is worth mentioning is that the CKP signal was reconstructed as a square wave, but this occurred sufficient enough for EEC and allowed to keep maximal circuit simplicity.
- simple voltage divider associated with transistor, for HO₂S signal. The resistors have been chosen in such a way that output voltage shall be equal 200mV or 800mV, depending on the transistor state.

Software necessary for the simulator was created in ANSI C language, in AVR Studio 4 environment. A great focus on modularity and future extensions has been made. Implemented software architecture is time-slotted, with no autonomous OS.

Two working modes are foreseen for the device. One can be called real-time emulation, in which the user can set a quantized value for a certain sensor (from its valid range). Second mode is an automatic data acquisition mode, in which the user interface is disabled, UART and monitor circuits activated and previously uploaded (into micro Flash memory) test vector is executed. The structure of test vector is described in detail in the simulator manual. It enables to define simulated sensor values, sampling time, idle time needed to cover EEC lag when executing control decision and samples number for one measurement.

4. Measured signals and data acquisition method

It was decided that two events will illustrate EEC unit control decision: injection duration and ignition timing. Both of those events were considered with reference to TDC (Top Dead Centre) of the crankshaft.

For injection in Ford Sierra 2.0DOHC EFI engine four electromagnetic valves are used. They are grouped in two pairs (1-3 and 2-4). Valves can be considered as bi-state elements driven by current. Their circuit is energized once each full crankshaft rotation. Energizing time shall be proportional to amount of fuel to be supplied to the cylinder. To measure this signal a simple circuit transferring current amount to voltage level is needed.

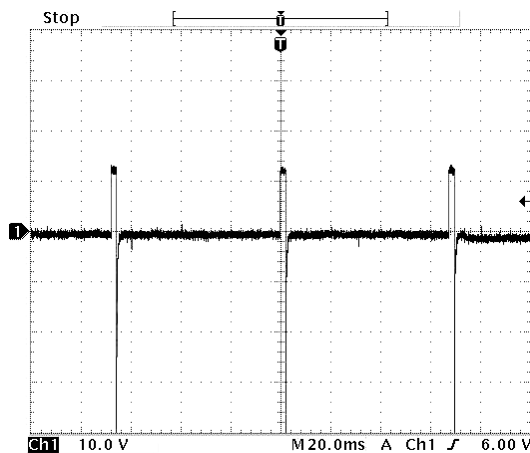


Fig. 7. Oscilloscope curve representing voltage applied to injector

The ignition angle is measured in crankshaft rotation degrees. They represent crankshaft position

(relatively to TDC occurrence) in which the ignition spark should appear. The proper ignition plug is selected mechanically by an ignition distributor. A following circuit was developed to measure the ignition moment.

The high voltage (about 7kV) present on ignition cable results in voltage induction in the test coil. The D1 and R1 elements are only for adopting induced voltage level. To measure the ignition signal the system must react on signal edge.

For the data being gathered a following scheme was accepted. After system power-up, an EEC unit is stimulated with conditions resembling a cold engine start and idle work for 15 minutes. Then the required sensor values are set. To ensure that EEC will have the time to react properly, a three second pause is made. Assuming that after that time the control decision is stable and unchangeable, 1000 samples is gathered. This is done by resetting the internal timers each time TDC occurs and continuously debouncing the EEC output signal in anticipation of a certain slope appearance. The trigger for each single measurement is the nearest TDC occurrence. The final registered value is an arithmetical average of previously collected in a whole step. After that the emulator is switching to next set of emulated sensor output values or finishes the activity. Gathered data and procedure status are being outputted to UART in parallel with measurements progression.

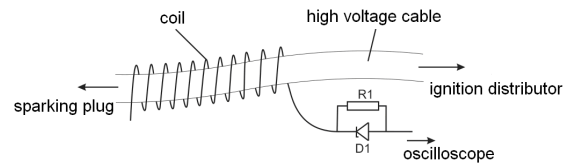


Fig. 8. Circuit used for measuring ignition moment

The reason behind taking an average for estimating the real value is an assumption that the signal is time stable and is not affected by hysteresis effect. Reason for having 1000 samples is that the earlier oscilloscope observation had shown that the control signals have the tendency to fluctuate 30-60us relatively to TDC moment. While sample taking time equals roughly 2us, having 1000 samples is aimed to eliminate this effect. Increasing samples number beyond that count would theoretically improve the precision, but make the overall process unrealistic in terms of time.

5. Example characteristics and final summary

The simulator outcome data was eventually stored and reworked on a PC. Data selection, filtration and visualization were done using Microsoft Excel and MathWorks Matlab. Obtained values were visualize.

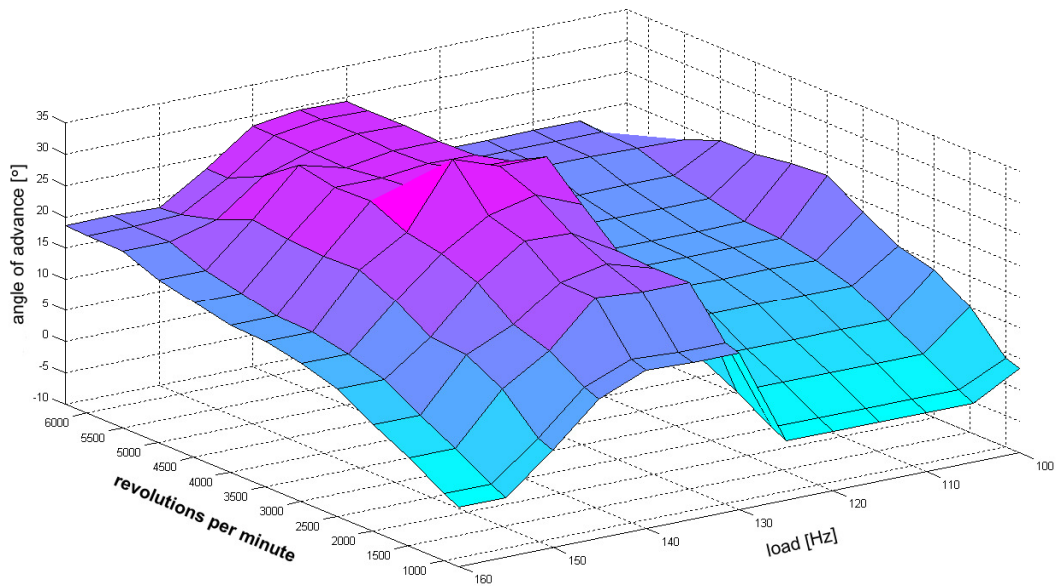


Fig. 9. Example of obtained ignition angle characteristics, $TP = 5^\circ$, $ECT = 0^\circ\text{C}$, $IAT = 0^\circ\text{C}$

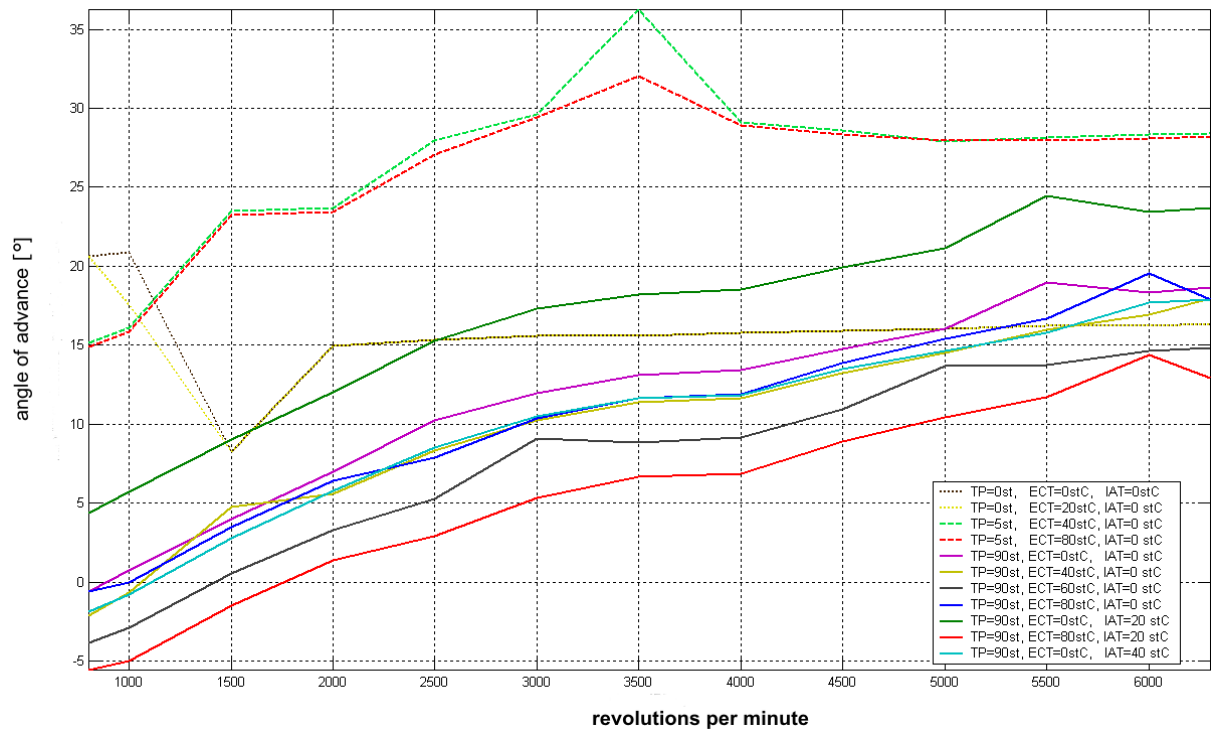


Fig. 10. Example of obtained ignition angle characteristics for different temperatures, $MAP = 140\text{Hz}$

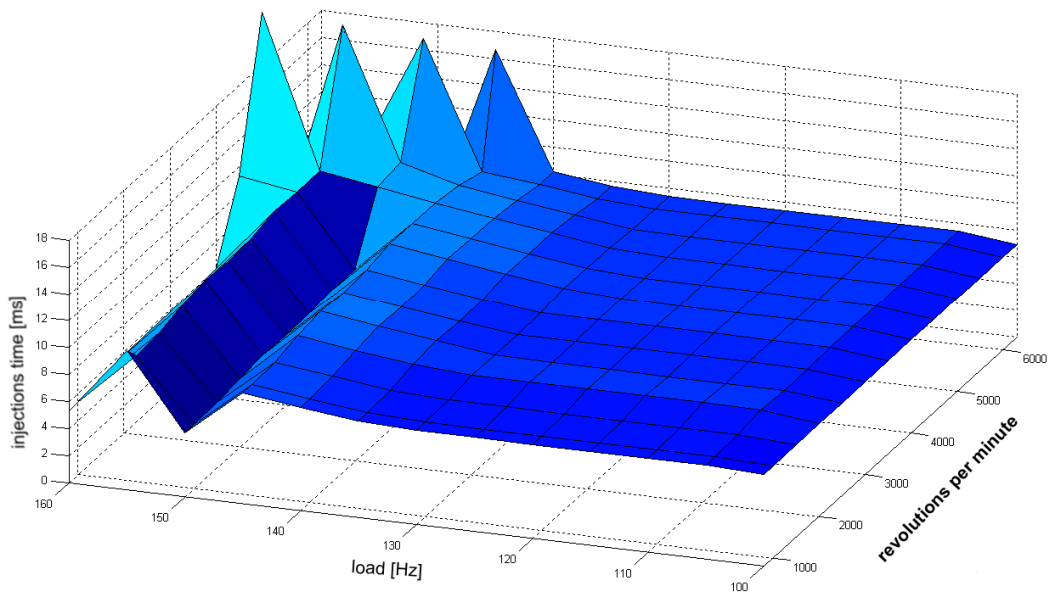


Fig. 11. Example of obtained filling characteristics, $TP = 90^\circ$, $ECT = 0^\circ\text{C}$, $IAT = 0^\circ\text{C}$

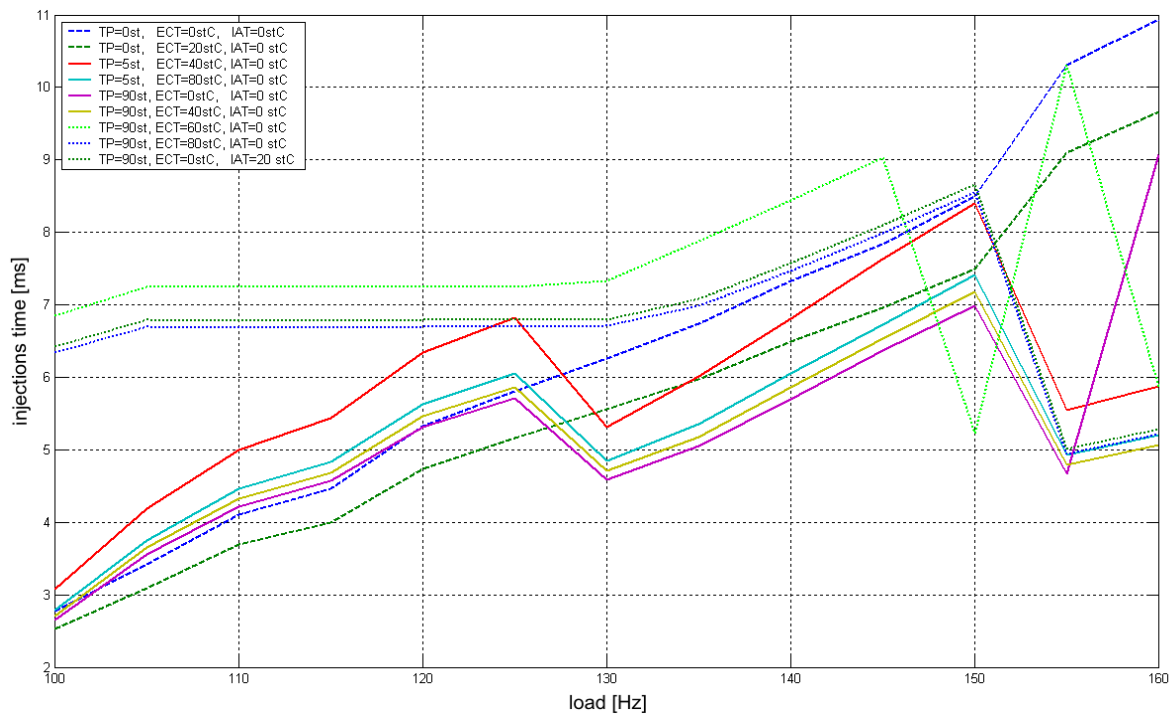


Fig. 12. Example of obtained filling characteristics for different temperatures, $MAP = 140\text{Hz}$

In general it can be said that the designed device itself proved well. When attached to EEC-IV it enabled to create a stable test environment and continuous data gathering. Obtained data can be perceived as representative. However, it must be noticed, that in case of other families of EECs, considering in particular variety of input sensors and their electrical characteristics, it is not effective to universalize this tool. Having the electronic circuit generic and microprocessor software paramete-

rized would increase by far the device complexity. The imaginary cost of creating and maintaining such a tool could be considered higher than potential benefits of its rather specific usage.

Other conclusion from above and other test series (not presented in this paper) is that the reverse engineering attempts, aimed to uncloak EEC internal control algorithms, are very hard to succeed. The vast number of factors that are influencing the momentary control decision, dynamic

adaptation mechanism presence and the fact that some of the constant parameters are estimated empirically by manufacturer during engine develop-

ment, makes the obtained results valid only for an qualitative rather than quantitative analysis.

Nomenclature/Skróty i oznaczenia

EEC Electronic Engine Control/centralna jednostka sterująca
CKP Crankshaft Position/czujnik położenia wału korbowego
TP Throttle Position/ czujnik położenia przepustnicy

MAP Mainfold Absolute Pressure/ czujnik podciśnienia w kolektorze dolotowym
ECT Engine Coolant Temp./ czujnik temp. cieczy chłodzącej
IAT Intake Air Temp./ czujnik temp. powietrza
H₂OS Heated Oxygen Sensor/ sonda lambda

Bibliography/Literatura

- [1] Jürgen Kasedorf, Zasilanie wtryskowe benzyną, Wydawnictwo Komunikacji i Łączności, Warszawa, 1989
[2] Andrzej Gajek, Zdzisław Juda, Czujniki. Mechatronika samochodowa, Wydawnictwo Komunikacji i Łączności, Warszawa, 2008
[3] Anton Herner, Hans-Jürgen Riehl, Elektrotechnika i elektronika w pojazdach samocho-

wych, Wydawnictwo Komunikacji i Łączności, Warszawa, 2009

- [4] Praca zbiorowa, Sterowanie silników o zapłonie iskrowym. Układy Motronic., Wydawnictwo Komunikacji i Łączności, Warszawa, 2008

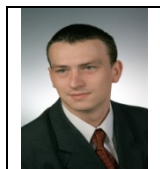
Mr Andrzej Kaźmierczak, DEng. – Professor in the Faculty of Mechanical Engineering at Wrocław University of Technology.

Dr hab. inż. Andrzej Kaźmierczak – profesor na Wydziale Mechanicznym Politechniki Wrocławskiej.



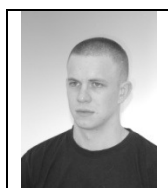
Mr Marcin Terelak, M.Eng. – PhD student in the Faculty of Mechanical Engineering at Wrocław University of Technology.

Mgr inż. – Marcin Terelak - doktorant na Wydziale Mechanicznym Politechniki Wrocławskiej



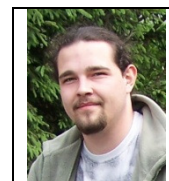
Mr Aleksadner Górniak, – PhD student in the Faculty of Mechanical Engineering at Wrocław University of Technology.

mgr. inż. Aleksadner Górniak - doktorant na Wydziale Mechanicznym Politechniki Wrocławskiej



Mr Konrad Krakowian, M.Eng. – PhD student in the Faculty of Mechanical Engineering at Wrocław University of Technology.

Mgr inż. – Konrad Krakowian doktorant na Wydziale Mechanicznym Politechniki Wrocławskiej.



Mr Paweł Kawaliło, M.Eng. – PhD student in the Faculty of Mechanical Engineering at Wrocław University of Technology.

Mgr inż. Paweł Kawaliło - doktorant na Wydziale Mechanicznym Politechniki Wrocławskiej

