



Norbert CHAMIER-GLISZCZYŃSKI

## **MODELLING OF SUSTAINABLE URBAN TRANSPORT SYSTEM**

### *Abstract*

*The present study covers issues of the modelling of the sustainable urban transport system in relation to an analysis presented of the transport behaviour of the dwellers of Polish cities. The analysis was conducted taking into consideration the relation of city travels that are realized by city dwellers on weekdays (Monday through Friday) as well as on Saturdays and Sundays. The results presented of the investigations into the transport behaviour of city dwellers are related to the group of those people (i.e. drivers) who travel in passenger cars (not on business) at least five times in a week. The following criteria were taken into account: the type of the means of transport as well as the distance covered while travelling in a city.*

### **INTRODUCTION**

Urban areas constitute the living space for over 60 per cent of the European population [4]. A migration of the population of a given state to urban or suburban areas has a substantial influence for the significance of the transport system in the area of the city and its peripheries. The city transport which functions in an urban agglomeration constitutes an inseparable element of the social life. At the same time, in spite of its key function, city transport involves a number of negative effects, i.e. an increased environment pollution, high noise emission levels, problems related to an overburden of the communications system and to the safety of road users. The idea of a sustainable city transport constitutes one of those elements which serve the purpose of a minimization of the effects of the city transport impact on the natural environment. Its objective is to decrease the number of travels in passenger cars.

### **1. SUSTAINABLE URBAN TRANSPORT SYSTEM**

The structure of a sustainable urban transport system will be presented by means of graph  $G$ , where each connection is represented in the form of a graph arc. Destination points will be represented in the form of the components of this graph. This graph is written in the following form [1, 2]:

$$G = \langle W, L \rangle \quad (1)$$

where:  $G$  – graph,  $W$  – set of components of graph,  $L$  – set of connections of graph.

For the purpose of the uniqueness of further considerations, we accept the following notation of the components and connections in graph  $G$  [1, 2]:

$$W = \{w(i) \equiv i: i = 1, 2, \dots, I\}; \quad i = \{1, 2, \dots, i, j, \dots, I\} \quad (2)$$

$$L = \{(w(i), w(j)): w(i), w(j) \in W, w(i) \neq w(j) \quad i, j \in I\} \quad (3)$$

When knowing the structure of the sustainable transport system and knowing the quantitative characteristics being defined, we can determine the model of sustainable urban transport system, which is written as an ordered triplet in the following form:

$$MSTS = \langle G, F, T \rangle \quad (4)$$

where: *MSTS* – model of sustainable urban transport system, *G* – graph, *F* – the set of the functions determined on the set of the components and connections of graph *G*,

$$F = \langle F_W, F_L \rangle \quad (5)$$

*F<sub>W</sub>* – the set of the functions determined on the set of the components of graph *G*,

$$F_W = \{\varphi_1, \varphi_2, \dots, \varphi_u\}, \quad u = 1, 2, \dots, U \quad (6)$$

*U* – the number of representations determined on the set of the components of graph *G*,

*F<sub>L</sub>* – the set of the functions determined on the set of the connections of graph *G*,

$$F_L = \{\gamma_1, \gamma_2, \dots, \gamma_z\}, \quad z = 1, 2, \dots, Z \quad (7)$$

*Z* – the set of the representations determined on the set of the connections of graph *G*,  
*T* – traffic flow.

The movement of city dwellers in a transport system of a given city is represented by the traffic flow *T* through the junctions and arcs of the city transport network. The traffic flows to the transport network through those points that constitute the flow sources, it moves through the individual indirect junctions and connections in the transport network and leaves the network at the outlet point of the traffic flow. In the case of travels in the city area, the residents move from beginning points (set *A*) through a number of intermediate points (set *V*) to finish points (set *B*), Fig. 1. There occurs a condition between the individual points:

$$W = A \cup V \cup B \quad (8)$$

where: *W* – set of components of graph *G*, *A* – set of beginning points, *V* – set of intermediate points, *B* – set of finish points.

The relationship between an ordered pair of points from sets *A* and *B* constitutes a transport relation:

$$A \subset W, \quad B \subset W \quad (9)$$

On this basis, we can define a set of all transport relations *TR* in the city's transport network:

$$TR \subset (A \times B) = \{(a, b): a \in A, b \in B\} \quad (10)$$

At the same time, for each transport relation, a set of connections between the individual components of the graph of the city's transport network is defined. This set is marked as  $P^{ab}$ , where  $P$  is the set of all the routes in the city's transport network:

$$P = \bigcup_{(a,b) \in TR} P^{ab} \quad (11)$$

The size of the traffic flow in the city's transport network between a distinguished pair of components  $(a, b)$  on the set of transport relations  $TR$  is defined as:

$$x(a, b) = x^{ab} \quad (12)$$

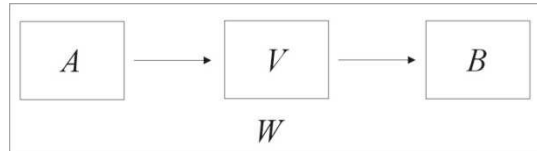

**Fig. 1.** Diagram of the movement of the traffic flow in the city's transport network:  $W$  – set of components of graph  $G$ ,  $A$  – set of sending points,  $V$  – set of intermediate points

## 2. PARAMETERS WHICH DESCRIBE TRANSPORT RELATIONS IN SUSTAINABLE URBAN TRANSPORT SYSTEM

### Time of the day

We assume that on Cartesian product  $X^{ab} \times W \times W$ ,  $dt$  representation is given of the following form:

$$dt: X^{ab} \times W \times W \rightarrow R^+ \quad (13)$$

where quantity  $dt(a, b)$  is a non-negative real number with an interpretation of time interval  $(i, j)$  which determines the time of the day in the relation of transport  $(a, b)$ . For the purpose of clarity, we will use the notation as below:

$$d((a, b), (i, j)) \equiv dt^{(a,b)}, \quad dt^{(a,b)} \geq 0 \quad (14)$$

### Distance

Quantity  $d(a, b)$  is a non-negative real number with an interpretation of the distance covered  $(i, j)$  in the relation of transport  $(a, b)$ :

$$d: X^{ab} \times W \times W \rightarrow R^+, \quad d((a, b), (i, j)) \equiv d^{(a,b)}, \quad d^{(a,b)} \geq 0 \quad (15)$$

### Duration time of the journeys

Quantity  $t(a, b)$  is a non-negative real number with an interpretation of the duration time of the journeys  $(i, j)$  of the relation of transport  $(a, b)$ :

$$t: X^{ab} \times W \times W \rightarrow R^+, \quad t((a, b), (i, j)) \equiv t^{(a,b)}, \quad t^{(a,b)} \geq 0 \quad (16)$$

### Means of transport

Quantity  $mt(a, b)$  is a non-negative real number with an interpretation of the selected means of transport  $(k)$  in the relation of transport  $(a, b)$ :

$$mt: X^{ab} \times W \times W \rightarrow R^+, \quad mt((a, b), (i, j)) \equiv mt^{(a,b)}, \quad mt^{(a,b)} \geq 0 \quad (17)$$

### 3. ANALYSIS OF THE TRAFFIC FLOW IN SUSTAINABLE URBAN TRANSPORT SYSTEM

#### Stage 1

The objective of the first stage was to determine a set of the destination points (components of graph  $G$ ) of the journeys of city dwellers in the period of seven days and set of connections of graph  $G$ :

$$W = \{w_1, w_2, w_3, w_4, w_5, w_6, w_7, w_8, w_9, w_{10}\} \quad (18)$$

where:  $w_1$  – home,  $w_2$  – workplace,  $w_3$  – shopping,  $w_4$  – next of workplace,  $w_5$  – visits of friend,  $w_6$  – next of shopping,  $w_7$  – escort,  $w_8$  – amusement,  $w_9$  – school,  $w_{10}$  – other,

$$L = \{l_1, l_2, l_3, l_4, l_5, l_6, l_7, l_8, l_9, l_{10}, l_{11}, l_{12}, l_{13}, l_{14}, l_{15}, l_{16}, l_{17}, l_{18}, l_{19}, l_{20}\} \quad (19)$$

where:  $l_1$  – connection  $w_1$ - $w_2$  (home-workplace),  $l_2$  – connection  $w_2$ - $w_1$  (workplace-home),  $l_3$  – connection  $w_1$ - $w_3$  (home-shopping),  $l_4$  – connection  $w_3$ - $w_1$  (shopping-home),  $l_5$  – connection  $w_2$ - $w_4$  (next of workplace-workplace),  $l_6$  – connection  $w_4$ - $w_1$  (next of workplace-home),

$l_7$  – connection  $w_2$ - $w_3$  (workplace-shopping),  $l_8$  – connection  $w_3$ - $w_6$  (shopping-next of shopping),  $l_9$  – connection  $w_6$ - $w_1$  (next of shopping-home),  $l_{10}$  – connection  $w_1$ - $w_5$  (home-visits to friend),  $l_{11}$  – connection  $w_5$ - $w_1$  (visits to friend-home),  $l_{12}$  – connection  $w_1$ - $w_7$  (home-escort),  $l_{13}$  – connection  $w_7$ - $w_1$  (escort-home),  $l_{14}$  – connection  $w_1$ - $w_8$  (home-amusement),  $l_{15}$  – connection  $w_8$ - $w_1$  (amusement-home),  $l_{16}$  – connection  $w_1$ - $w_9$  (home-school),  $l_{17}$  – connection  $w_9$ - $w_1$  (school-home),  $l_{18}$  – connection  $w_1$ - $w_{10}$  (home-other),  $l_{19}$  – connection  $w_{10}$ - $w_1$  (other-home),  $l_{20}$  – connection  $w_1$ - $w_1$  (home-home).

When having a set of components  $W$  and a set of connections  $L$  between these components, graph  $G$  can be built which presents the communication related behaviour of city dwellers (Fig. 2).

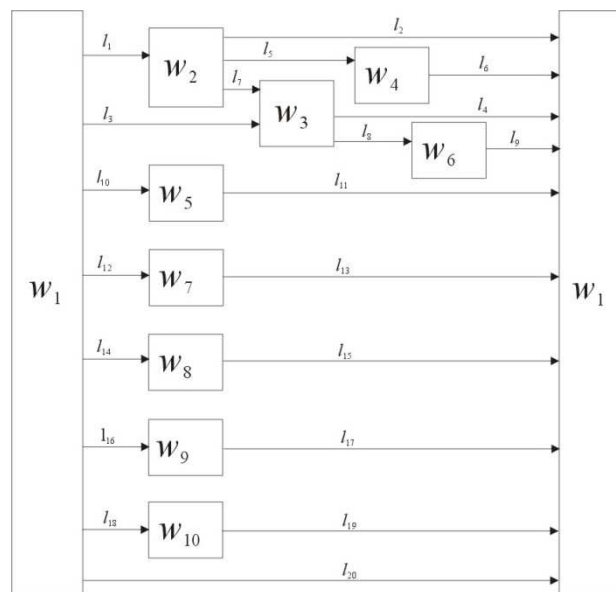

**Fig. 2.** The graph  $G$  of the journeys:  $w_1$  – home,  $w_2$  – workplace,  $w_3$  – shopping,  $w_4$  – next of workplace,  $w_5$  – visits to friend,  $w_6$  – next of shopping,  $w_7$  – escort,  $w_8$  – amusement,  $w_9$  – school,  $w_{10}$  – other,  $l_1, l_2, \dots, l_{20}$ , – connections  $L$  of graph  $G$

## Stage 2

The objective of the second stage was to determine the constituent elements of the individual parameters that characterize the transport relation in the city transport network.

On the basis of an analysis of the papers concerning the investigation methodology of the traffic intensity, one day, i.e. 24 hours was divided into five time intervals (20). This is tantamount to taking into consideration in the times of the day the morning and afternoon rush hours as well as the traffic in the evening and at night.

$$dt = \{dt_1, dt_2, dt_3, dt_4, dt_5\} \quad (20)$$

where:  $dt$  – time of the day,  $dt_1$  – 6:00am-9:59am,  $dt_2$  – 10:00am-2:59pm,  $dt_3$  – 3:00pm-5:59pm,  $dt_4$  – 6:00pm-9:59pm,  $dt_5$  – 10:00pm-5:59am.

The distance covered during journeys within the city area was divided into two ranges:

$$d = \{d_1, d_2\} \quad (21)$$

where:  $d$  – distance,  $d_1$  – short distance (up to 5 km),  $d_2$  – long distance (over 5 km).

Introductory investigations into the time of journeys within city areas demonstrated that the greatest time differentiation occurs in the range from 5 to 30 minutes. Taking into consideration the results of these investigations, the journey time was divided into seven time intervals:

$$t = \{t_1, t_2, t_3, t_4, t_5, t_6, t_7\} \quad (22)$$

where:  $t$  – duration time,  $t_1$  – up to 5 min,  $t_2$  – 6-10 min,  $t_3$  – 11-15 min,  $t_4$  – 16-20 min,  $t_5$  – 21-30 min,  $t_6$  – 31-60 min,  $t_7$  – over 60 min.

Four means of transport were used for trips in the city area:

$$mt = \{mt_1, mt_2, mt_3, mt_4\} \quad (23)$$

where:  $mt$  – means of transport,  $mt_1$  – passenger car,  $mt_2$  – public transport,  $mt_3$  – on foot,  $mt_4$  – other.

## 4. TRANSPORT BEHAVIOUR OF CITY DWELLERS

At this stage, an analysis was presented that covers the transport behaviour of the dwellers of Polish cities. For this purpose, the results were used of the report entitled “Monitoring of social attitudes in relation to sustainable transport”. The research into the transport behaviour of city dwellers was conducted on a group of those dwellers who trip in passenger cars (not on business) at least five times in a week. The transport behaviour of drivers in 94 Polish cities was investigated [3].

When taking into account all the journeys that are made by drivers, two areas were isolated, i.e. those travels that are realized by city dwellers on weekdays (Monday through Friday) as well as journeys that are made on Saturdays and Sundays. On weekdays, the highest percentage, i.e. 17 per cent, is travels from home to workplace and from workplace to home (Fig. 3). A high percentage was also observed in the case of relations from home to shops (8%) and from shops to home (9%) (Fig. 3). Concerning city travels on Saturdays and Sundays, most of these are realized in the relation of home-shops (11%), shops-home (11%)

as well as home-visits to friends (9%) and relatives and visits to friend-home (9%) and relatives (Fig. 3).

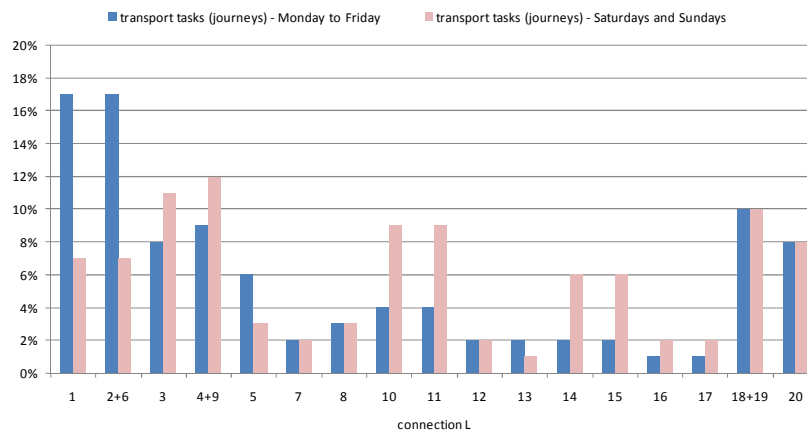

**Fig. 3.** The transport tasks (journeys) realized in the period from Monday to Friday and Saturdays and Sundays [3]: 1 – connection ( $l_1$ ) home-workplace, 2 + 6 – connection ( $l_2$ ) workplace-home + connection ( $l_6$ ) next of workplace-home, 3 – connection ( $l_3$ ) home-shopping, 4 – connection ( $l_4$ ) shopping-home, 5 – connection ( $l_5$ ) next of workplace-workplace, 7 – connection ( $l_7$ ) workplace-shopping, 8 – connection ( $l_8$ ) shopping-next of shopping, 9 – connection ( $l_9$ ) next of shopping-home, 10 – connection ( $l_{10}$ ) home-visits to friend, 11 – connection ( $l_{11}$ ) visits to friend-home, 12 – connection ( $l_{12}$ ) home-escort, 13 – connection ( $l_{13}$ ) escort-home, 14 – connection ( $l_{14}$ ) home-amusement, 15 – connection ( $l_{15}$ ) amusement-home, 16 – connection ( $l_{16}$ ) home-school, 17 – connection ( $l_{17}$ ) school-home, 18 + 19 – connection ( $l_{18}$ ) home-other + connection ( $l_{19}$ ) other-home, 20 – connection ( $l_{20}$ ) home-home

Among all the journeys from Monday to Friday in the area of the selected towns and cities, most of them were made in passenger cars (87%). Every eleventh journey was on foot (9%) and only as few as 1% of travellers chose the city public transport to satisfy their transport needs.

When analyzing journeys that are made in passenger cars on weekdays, it was noted that the highest percentage was constituted by journeys in the relation from home to workplace (18%) and from workplace to home (18%) as well as in the relation from home to shops (7%) and from shops to home (8%) (Fig. 4a). On Saturdays and Sundays, the highest percentage was travels in the relation from home to shops (11%) and from shops home (13%) and in the relation home-visits to friends (8%) and relatives as well as visits to friend-home (8%) and relatives (Fig. 4a).

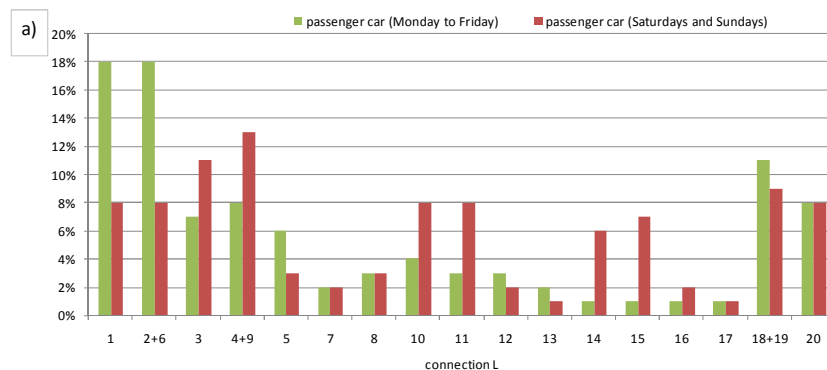

**Fig.4a.** Use of the means of transport depending on the relation of the journey [3]: a) passenger car. Marking of journey relations (connection L): cf. Fig. 3.

In the case of journeys on foot, journeys dominated in the relation of home-shops (17%) and shops-home (16%) on weekdays (Fig. 4b). On Saturdays and Sundays, the greatest percentage was related to journeys on foot in the relation of visits to friends and relatives-home (15%), home-shops (13%) as well as home- visits to friends(11%) and relatives (Fig. 4b).

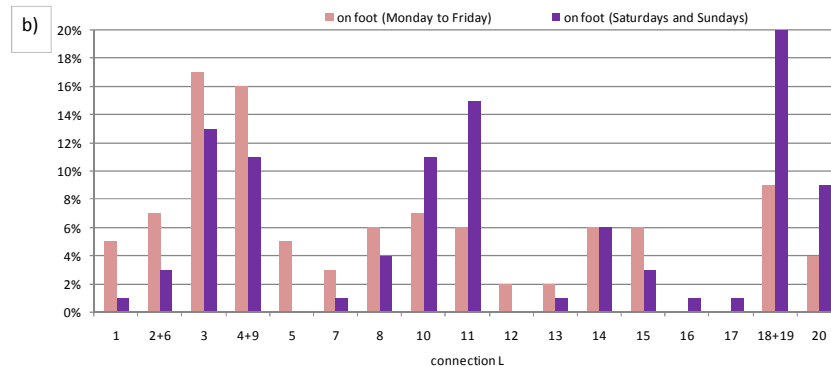

**Fig.4b.** Use of the means of transport depending on the relation of the journey [3]: b) on foot. Marking of journey relations (connection L): cf. Fig. 3.

The distances that are covered by the city dwellers under examinations is journeys over short distances up to 5 kilometres (49%) as well as over long distances over 5 kilometres (51%). From among those journeys that are realized on weekdays over short distances, the greatest percentage was journeys in the relation of home-workplace and workplace-home (14 per cent each) and in the relation of home-shops and shops-home (13 per cent each) (Fig. 5a). On Saturdays and Sundays, travels realized over short distances are in the relations of shops-home (17%), home-shops (16%) as well as home-home (8%) (Fig. 5a).

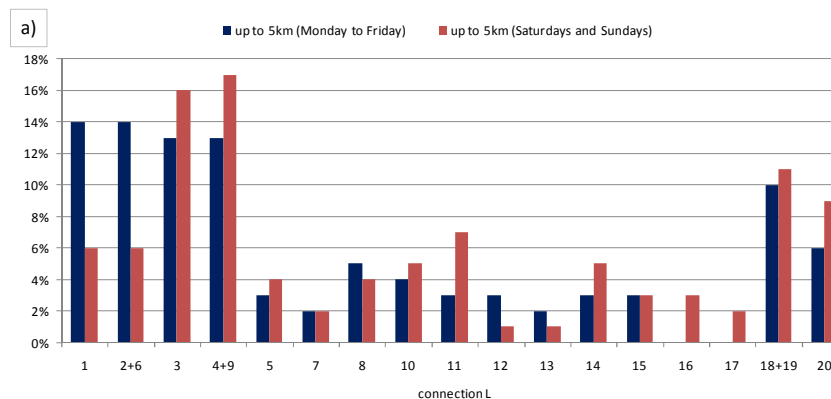
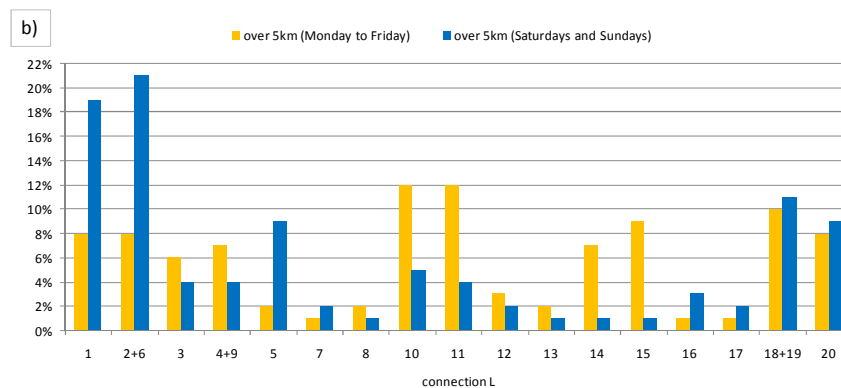

**Fig.5a.** The distance covered during journeys within the city [3]: a) short distance up to 5 km. Marking of journey relations (connection L): cf. Fig. 3.

Concerning journeys made by city dwellers over long distances on weekdays, the greatest percentage is journeys that are realized in the relation from workplace to home and from home to workplace (21 per cent and 19 per cent respectively) (Fig. 5b). On Saturdays and Sundays, city dwellers most frequently travel over long distances in the relation of home-visits to friends and relatives as well as home-visits to friends and relatives-home (12 per cent each) (Fig. 5b).

## CONCLUSIONS

The report on the communication behaviour of city dwellers demonstrated that in Polish cities, it is the passenger car that is the dominating means of transport. City dwellers travel in passenger cars both on short and long distances irrespective of the duration of the journey. This is true both of journeys that are realized on weekdays and those that are realized on Saturdays and Sundays. Such a high level of the use of passenger cars in city travels generates high external costs related to air and soil pollution, noise emission, road accidents and the quantities of waste in the form end-of life vehicles. Concerning these alarming results, it is justifiable to conduct research into a reduction of the use of passenger cars in city travels. The author of the present study uses the model presented of a sustainable urban transport system in optimization investigations related to the minimization of those external costs that are generated by city travels.



**Fig.5b.** The distance covered during journeys within the city [3]: b) long distance over 5 km. Marking of journey relations (connection L): cf. Fig. 3.

## MODELOWANIE ZRÓWNOWAŻONEGO SYSTEMU TRANSPORTOWEGO W MIASTACH

### Streszczenie

W pracy zaprezentowano problematykę modelowania zrównoważonego systemu transportowego w miastach w odniesieniu do zaprezentowanej analizy zachowań transportowych mieszkańców polskich miast. Analiza została przeprowadzona w odniesieniu do relacji podróży miejskich realizowanych przez mieszkańców miast w dni powszednie (od poniedziałku do piątku) oraz w soboty i niedziele. Zaprezentowane wyniki badań zachowań transportowych mieszkańców miast odnoszą się do grupy osób (kierowców) wykonujących przynajmniej pięć podróży samochodem osobowym (nie służbowo) w ciągu tygodnia. Uwzględniono kryteria: rodzaj środka transportu oraz dystans podróży miejskich.

## REFERENCES

1. Ambroziak T.: *Modelowanie procesów technologicznych w transporcie*. Prace Naukowe, Transport 40, Oficyna Wydawnicza Politechniki Warszawskiej, Warszawa 1998.
2. Jacyna M.: *Modelowanie i ocena systemów transportowych*. OWPW, Warszawa 2009.
3. Raport: *Monitorowanie postaw społecznych w zakresie zrównoważonego transportu*. PBS DGA/Ministerstwo Środowiska, Sopot 2010.



4. *Opinion of the European Economic and Social Committee on the Action Plan on Urban Mobility*, COM(2009), 2011/C 21/10.

***Autor:***

**dr inż. Norbert CHAMIER-GLISZCZYŃSKI** – Politechnika Koszalińska.