

Evaluation of Backwater Flow Over Broad Crest Weir Using Matlab Simulink

Fatin M. Shehab¹

¹ Geomatics Department, Technical Engineering College, Northern Technical University, Mosul, Iraq

E-mail: fatin.m.alobaid@ntu.edu.iq

ABSTRACT

The main purpose of the construction of weirs is to raise the water level and control it in front of the weir. It is important to know the longitudinal section of the variable flow behind the weir in the open channels. A total of 30 experiments were conducted in a horizontal laboratory channel with a length of 12 m, a width of 0.5 m, and a depth of 0.45 m. The longitudinal flow section was evaluated follow a step-by-step process under the influence of five different slopes of the channel bottom with five different flow discharges (0.035, 0.028, 0.022, 0.016 and 0.012 m³/sec), for each slope. After that, a Matlab simulation model was built in order to evaluate the longitudinal section of water surface, which is a plot of the water level along the length of the structure. The MATLAB Simulink gave more accurate results at speed that does not exceed seconds, as long mathematical equations.

Keywords: backwater flow, Broad crest weir, MATLAB Simulink, submerged dam, CFD.

INTRODUCTION

It is essential to state that backwater flow refers to the height in water level in the upstream at submerged dams according obstruction due to this dam. This natural phenomenon happens when the flow of water is exactly restricted by the existence of these dams causing increasing in the water level at the upstream. We can say that calculation of backwater flow over submerged dam's deepened on various factors such as the dam geometry, channel characteristics, and the flow conditions. A weir can be considered as the main barrier or dam-like structure built across rivers or channels in order to control the flow of water (Noori and Juma, 2009). As with the case of backwater flow over submerged dams, more the one method can be used, such methods are analytical solutions, numerical models, and empirical formulas. Thus, fundamental methods are the energy equation approach, which refers to the conservation of energy line along a reach of open channel flow. Energy equation represents the total energy head at any point in the channel

due to the elevation head, pressure head, and velocity head. To determine the change in water level caused by the presence of the dam, energy equation must apply at the upstream and downstream of the dam. Moreover, the water surface profile behind dams or weir is affected by various factors, such as the height of the weir crest, discharge rate, and the characteristics of the channel downstream the weir (Kalajdzisalihović et al., 2021; Al-Hashimi et al., 2016).

To add more information, these present basic calculations are so essential and useful, they can actually help engineers designing constructing in controlling and managing weirs so as to accurately ensure safe and efficient flow control. In addition to this, civil and modern engineers are capable of using both computer model and engineering analyses so that they can estimate the natural longitudinal section of water flow upstream the dams. Within the scope of the remarkable analytical method, it can be perceived that numerical models are implied so as to distinctively simulate backwater flow being over the previously mentioned submerged dams. Moreover, these present

and prominent models repeatedly adopt computational fluid dynamics (CFD) techniques in order to solve the complicated equations which also control the fluid flow (Hargreaves et al., 2007). Thus numerical models can support the detailed prediction of the backwater flow pattern by discretizing the control into small units and solving the information equations interactively. It can be said that MATLAB Simulation can be used to permit exact calculations of water flow and surface water levels being in the hydraulic structures which are so beneficial for civil engineers in designing more effective structures. Added to that MATLAB Simulation can be used to minimize the need for both expensive physical testing and experimentation, saving cost and resources. In accordance with this, the practical experience of civil engineers working in the design and construction of dams also hydraulic projects can be beneficial (Azimi and Rajaratanam, 2009; Irzooki and Yass, 2015).

Fulasa (2019) was investigated the flow over various shape of broad-crested weirs and simulated by computational fluid dynamic models (CFD). The water surface profiles over – a sharp-edged broad-crested weirs were measured in laboratory, then comparison between the results of the numerical models and experimental results was done. This study demonstrates the accuracy of (CFD) models, the free surface modeling of open FOAM, thus it is considered the most accurate, economical and efficient for designing construction and operation.

Yuce et al. (2015) studied the effects of computational fluid dynamics (CFD) modeling on the impact of geometrical characteristic of oblique cylindrical weirs on discharge features, like velocity distribution, pressure distribution, and water depth over the weir. The results of the simulation analyses proved that the oblique cylindrical weirs have significant effects on the flow velocity, pressure, and the water surface profile over the weir, also, it showed that the minimum velocity as the weir was perpendicular on the flow direction.

Aydin (2012) investigated the surface flow over a triangular side weir, and it was modeled by using volume of fluid method (VOF) to show the flow characteristics in subcritical flow. The volume method in open channel boundary conditions was the most effective for obtaining the surface shape over labyrinth side weirs and also the (CFD) simulation may be useful to determine flow characteristics of hydraulic structures

including free surface water flow like side weirs when used with physical model studies.

Daneshfaraza et al. (2019) examined three-dimensional numerical modelling for flow over broad-crested weir with different slopes, using numerical simulation. A comparison between the models showed the correlation between the simulation results and experimental data.

In this study, modeling and simulating were developed by using Matlab Simulink to evaluate the longitudinal section of water surface to obtain the best results at a record time and to compare the results obtained using the MATLAB Simulink model with the results obtained using equations and traditional methods. In previous studies, researchers used the Matlab Simulink model method. In this study, a block diagram model was created using MATLAB Simulink that simulates the equations for evaluating the longitudinal section of the water surface. Comparing the current study, it was found that the circuit obtained using a new technology in the field of Matlab Simulink gave more accurate models at a speed that does not exceed seconds, as long mathematical equations that take a long time to solve have been eliminated.

MATERIAL AND METHODS

This study was conducted in the Hydraulic Laboratory of Dams Engineering Department of Northern Technical University, Iraq. Experimental data were achieved by calibrated instruments and standard techniques which were highly reliable and accurate. The flume is rectangular with cross section 0.5 m wide, 0.50 m deep and 12 m long with a Manning coefficient of 0.015. It has vertical glass sidewalls and metal bottom. In total, 30 experiments were performed with five bed slope in the channel (Figure 1). The water surface levels were measured at different locations with an accurate point gauge reading to 0.1 mm. Discharge was measured by a pre-calibrated triangle weir installed at the channel inlet. A board crest weir with a height of 28 cm, width of 50 cm and side thickness of 8 cm, made of thermos-stone and painted to decrease the surface roughness of the models, has been used. To guarantee stability of water surface levels and uniform flow with very low turbulence, the models were fixed at a distance of 5 m from the channel inlet. All measurements were carried out at the center line of the channel width. Experimental results gave a high validity.



Fig. 1. General view of the laboratory channel with a broad crest weir

EVALUATION LONGITUDINAL SECTION USING A STEP-BY-STEP PROCESS

The water surface profile behind weirs refers to the shape and elevation of the water surface downstream of a weir structure. A weir is a barrier or dam-like structure built across a river or channel to control the flow of water. The water surface profile behind a weir is influenced by various factors, including the height of the weir crest, the discharge rate, and the characteristics of the channel downstream of the weir (Madadi et al., 2014; Taghavi and Ghodousi, 2015).

The step-by-step method for determining the depth change in the flow of gradually changing open channels is an approximate method based mainly on the use of regular flow equations, assuming that the hydrostatic pressure distribution and the flow lines are almost parallel and that the slope of the channel bottom S is small (Parsaie et al., 2022). In this method, the length of the channel in which the longitudinal section of the liquid surface is to be evaluated is divided into parts or stretches in which the depth difference is not large in order to reduce the error that may occur from this approximation, as shown in Figure 2 for the shape of the backwater in a long channel for a submersible dam.

In deriving the equation for evaluating the shape of the backwater surface, the one-dimensional analysis method was followed and it was assumed that the energy coefficient K_o is equal to one. Figure 3 shows an extension between two sections close to each other of a long channel with variable flow. The figure has been drawn on a distorted scale, meaning that it has been exaggerated on the vertical scale to show the different charges. It should be noted that the energy line E.L., as well as the longitudinal section of the water surface, are both concave curves or convexities in the variable flow according to the energy equation, and they are not straight except in the case of regular flow, where they are also parallel and parallel to the bottom line of the channel, and this does not represent the slope of the power line drawn straight in the figure, except the approximate rate of slope between sections 1 and 2 that are relatively close to each other.

To derive the energy equation between sections 1 and 2

$$Z_1 + y_1 + \frac{v_1^2}{2g} = y_2 + \frac{v_2^2}{2g} + h_f \quad (1)$$

Substitute for Z_1 and for h_f from the two relationships

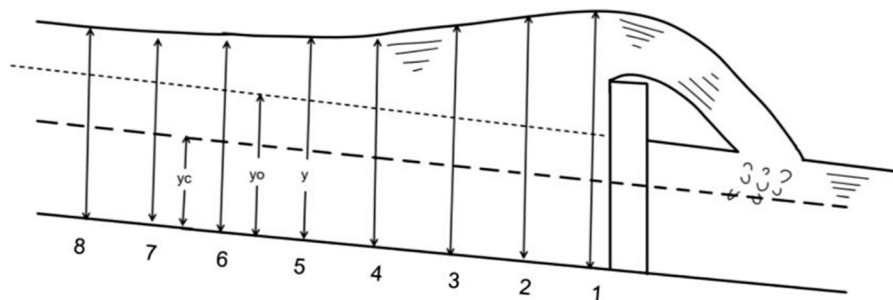

Fig. 2. Backwater curve upstream of weir

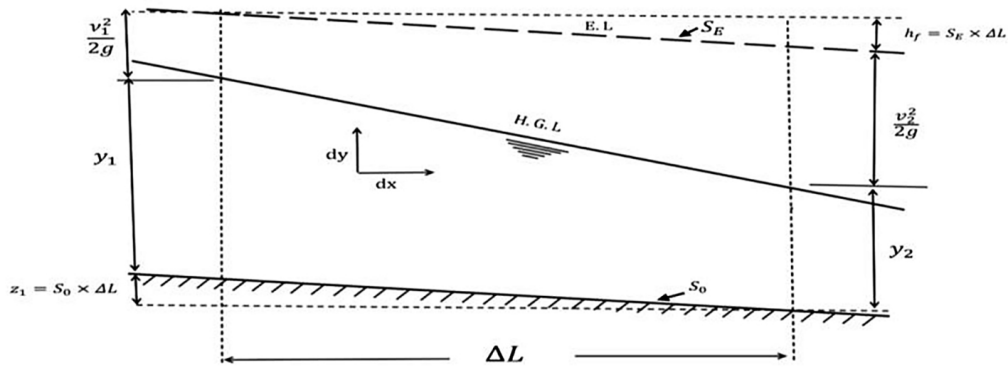

Fig. 3. The extension between two sections

$$z_1 = S_o \times \Delta L \quad (2)$$

$$h_f = S_E \times \Delta L \quad (3)$$

where: S_o symbolizes the slope of the bottom of the channel and S_E is the slope of the energy head line, both of which are positive dimensions when the channel slopes downward, and ΔL symbolizes the length of the extension between segments 1 and 2, and thus the following relationship is obtained

$$S_o \cdot \Delta L + y_1 + \frac{v_1^2}{2g} = y_2 + \frac{v_2^2}{2g} + S_E \times \Delta L \quad (4)$$

From which it can be found that the extension between the two syllables is:

$$\Delta L = \frac{(y_2 + \frac{v_2^2}{2g}) - (y_1 + \frac{v_1^2}{2g})}{S_o - S_E} \quad (5)$$

$$H_{S_1} = (y_1 + \frac{v_1^2}{2g}) \quad (6)$$

It is also possible, by substituting in the specific charge relation, to write the equation in the following form

$$\Delta L = \frac{H_{S_2} - H_{S_1}}{S_o - S_E} \quad (7)$$

Since the power line is curved, its slope rate was approximated using the average values of S_E in sections 1 and 2, and approximation was used to estimate the value of S_E .

From Chezy's equation for uniform runoff

$$V = \sqrt{RS_E} \quad (8)$$

That results

$$S_E = \frac{V^2}{C^2 R} \quad (9)$$

Let Equation 7 take the practical form

$$\Delta L = \frac{H_{S_2} - H_{S_1}}{S_o - S_{Em}} \quad (10)$$

$$S_{Em} = \left(\frac{V^2}{C^2 R} \right)_m = \frac{S_{E_1} + S_{E_2}}{2} \quad (11)$$

where: C can be estimated from the Chezy-Manning equation:

$$C = \frac{R^{1/6}}{n} \quad (12)$$

$$A = B \cdot y; P = B + 2y; R = \frac{A}{P} \quad (13)$$

MATLAB Simulink

MATLAB Simulation is a very useful tool for modeling and simulating in different application in hydraulic structures, such as dams, weirs and spillway. Its ability to deal with complex equations and simulation. It is used for modeling the hydraulic behavior of different types of structures, such as valves, gates, and pumps (Naghavi et al., 2011).

A MATLAB Simulink model has been built to evaluating the longitudinal section of flow in step-by stepped method, so that the dimensions of the channel, depth of the water in the channel, are show the input values while ΔL is represented the output results in the circuit Figure (4).

RESULTS

The water surface profile over submerged dams and weirs depend on various factors, such

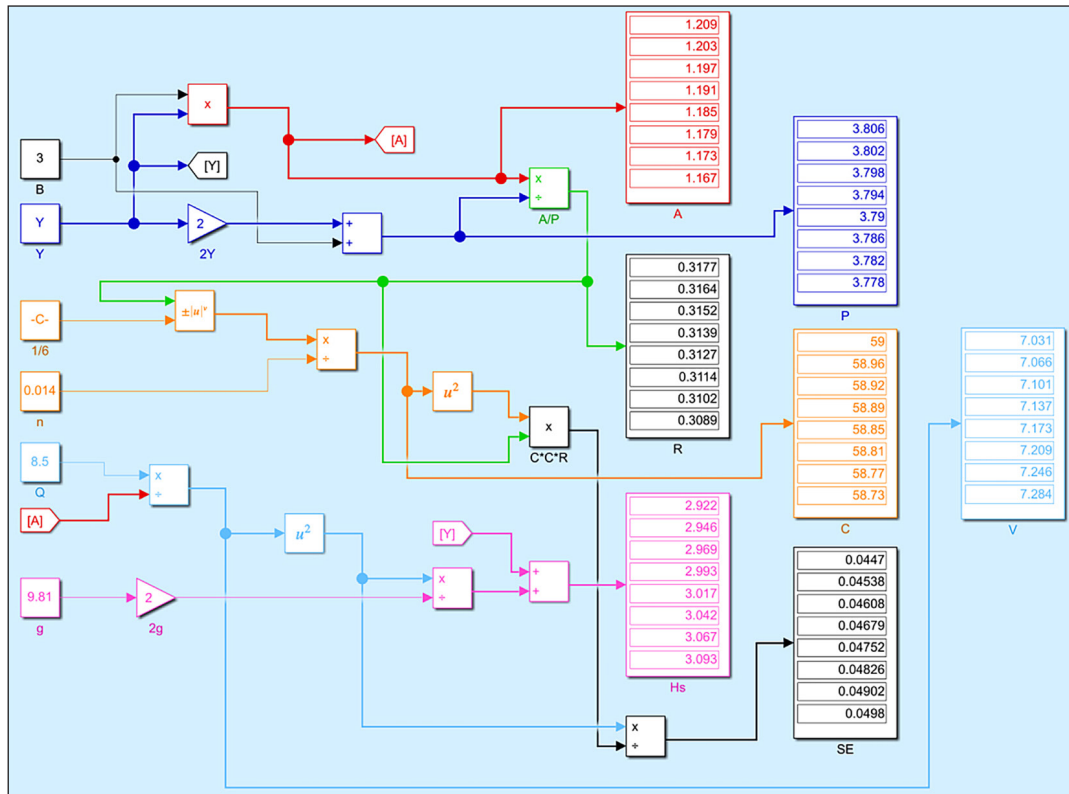

Fig. 4. The extension between two sections

as, dam geometry, channel characteristics and flow conditions. To evaluate the backwater flow over submerged dams, several methods can be used, including analytical solutions, numerical models, and empirical formulas. In this study, modeling and simulating were developed by using MATLAB Simulink to evaluate the longitudinal section of the water surface to obtain the best results. In Table 1–5, which represents the values of (ΔL) with a change in (y) at flow discharges (0.035, 0.028, 0.022, 0.016 and 0.012 m³/s), respectively, with bed channel slope of 0.003 for laminar flow, it takes a few

seconds, which makes the method characterized by speed and accuracy in the results. Fifteen trials were tested by selecting three channel slopes and five discharges. The shape of the water surface was drawn for each case and the results achieved from the MATLAB model were compared with the measured and evaluated results manually, where the results obtained from the MATLAB circle were more accurate. Figure 5 shows the relationship between water depth and discharge for eight sections. Figure 6 represents the runoff surface profile at different discharges for $S_o = 0.003$. Figure 7, and 8 show

Table 1. Summary of calculations for the backflow water profile for the channel data: $Q_1 = 0.035$ m³/sec, $S_o = 0.003$, $n = 0.015$, $B = 0.5$ m

Run No.	Y (m)	A (m ²)	P (m)	R (m)	C	V (m/s)	Hs	S_E	ΔL (m)
1	0.403	0.2015	1.306	0.1543	48.82	0.1737	0.4045	8.203	
2	0.401	0.2005	1.302	0.1540	48.81	0.1746	0.4026	8.307	0.6513
3	0.399	0.1995	1.298	0.1537	48.79	0.1754	0.4006	8.412	0.6858
4	0.397	0.1985	1.294	0.1534	48.78	0.1763	0.3986	8.518	0.6860
5	0.395	0.1975	1.290	0.1531	48.76	0.1772	0.3966	8.627	0.6863
6	0.393	0.1965	1.286	0.1528	48.74	0.1781	0.3946	8.738	0.6865
7	0.391	0.1955	1.282	0.1525	48.73	0.1790	0.3926	8.851	0.6868
8	0.389	0.1945	1.278	0.1522	48.71	0.1799	0.3907	8.967	0.6527

Table 2. Summary of calculations for the backflow water profile for the channel data: $Q_1 = 0.028 \text{ m}^3/\text{sec}$, $S_o = 0.003$, $n = 0.015$, $B = 0.5 \text{ m}$

Run No.	Y (m)	A (m ²)	P (m)	R (m)	C	V (m/s)	Hs	S _E	ΔL (m)
1	0.388	0.194	1.276	0.1520	48.7	0.1443	0.3891	5.776	0.000
2	0.386	0.193	1.272	0.1517	48.69	0.1451	0.3871	5.852	0.6798
3	0.384	0.192	1.268	0.1514	48.67	0.1458	0.3851	5.929	0.680
4	0.382	0.191	1.264	0.1511	48.65	0.1466	0.3831	6.008	0.6802
5	0.380	0.190	1.260	0.1508	48.64	0.1474	0.3811	6.088	0.6804
6	0.378	0.189	1.256	0.1505	48.62	0.1481	0.3791	6.170	0.6806
7	0.376	0.188	1.252	0.1502	48.60	0.1489	0.3771	6.253	0.6808
8	0.374	0.187	1.248	0.1498	48.59	0.1497	0.3751	6.338	0.681

Table 3. Summary of calculations for the backflow water profile for the channel data: $Q_1 = 0.022 \text{ m}^3/\text{sec}$, $S_o = 0.003$, $n = 0.015$, $B = 0.5 \text{ m}$

Run No.	Y (m)	A (m ²)	P (m)	R (m)	C	V (m/s)	Hs	S _E	ΔL (m)
1	0.376	0.188	1.252	0.1502	48.60	0.117	0.3767	3.86	0.00
2	0.374	0.187	1.248	0.1498	48.59	0.1176	0.3747	3.913	0.6754
3	0.372	0.186	1.244	0.1495	48.57	0.1183	0.3727	3.967	0.6755
4	0.370	0.185	1.240	0.1492	48.55	0.1189	0.3707	4.021	0.6757
5	0.368	0.184	1.236	0.1489	48.53	0.1196	0.3687	4.077	0.6758
6	0.366	0.183	1.232	0.1485	48.52	0.1202	0.3667	4.137	0.6759
7	0.364	0.182	1.228	0.1482	48.50	0.1209	0.3647	4.192	0.6761
8	0.362	0.181	1.224	0.1479	48.48	0.1215	0.3628	4.251	0.6424

Table 4. Summary of calculations for the backflow water profile for the channel data: $Q_1 = 0.016 \text{ m}^3/\text{sec}$, $S_o = 0.003$, $n = 0.015$, $B = 0.5 \text{ m}$

Run No.	Y (m)	A (m ²)	P (m)	R (m)	C	V (m/s)	Hs	SE	ΔL (m)
1	0.362	0.181	1.224	0.1479	48.48	0.0884	0.3624	2.248	0.000
2	0.360	0.180	1.220	0.1475	48.46	0.0889	0.3604	2.280	0.6717
3	0.358	0.179	1.216	0.1472	48.44	0.0894	0.3584	2.313	0.6718
4	0.356	0.178	1.212	0.1469	48.42	0.0899	0.3564	2.346	0.6719
5	0.354	0.177	1.208	0.1465	48.41	0.0904	0.3544	2.380	0.6720
6	0.352	0.176	1.204	0.1462	48.39	0.0909	0.3524	2.415	0.6720
7	0.350	0.175	1.200	0.1458	48.37	0.0914	0.3504	2.450	0.6721
8	0.348	0.174	1.196	0.1455	48.35	0.0919	0.3484	2.486	0.6722

Table 5. Summary of calculations for the backflow water profile for the channel data: $Q_1 = 0.012 \text{ m}^3/\text{sec}$, $S_o = 0.003$, $n = 0.015$, $B = 0.5 \text{ m}$

Run No.	Y (m)	A (m ²)	P (m)	R (m)	C	V (m/s)	Hs	S _E	ΔL (m)
1	0.348	0.174	1.196	0.1455	48.35	0.0690	0.3482	1.399	0.000
2	0.346	0.173	1.192	0.1451	48.33	0.0694	0.3462	1.419	0.6698
3	0.344	0.172	1.188	0.1448	48.31	0.0698	0.3442	1.441	0.6699
4	0.342	0.171	1.184	0.1444	48.29	0.0702	0.3423	1.462	0.6364
5	0.340	0.170	1.180	0.1441	48.27	0.0706	0.3403	1.484	0.6700
6	0.338	0.169	1.176	0.1437	48.25	0.0710	0.3383	1.507	0.6700
7	0.336	0.168	1.142	0.1433	48.23	0.0714	0.3363	1.530	0.6701
8	0.334	0.167	1.168	0.1430	48.21	0.0719	0.3343	1.554	0.6701

the contour lines of the velocity distribution on the water surface, which show the flow behavior above and below the weir at $Q = 0.012 \text{ m}^3/\text{s}$ and $0.035 \text{ m}^3/\text{s}$, respectively. The comparison between the height of flow above and below the weir for maximum and minimum discharge was drawn using the ANSIS Flow in Figure 9.

DISCUSSION

In previous studies, researchers used the Matlab Simulink models method. In this study, a simulation model circuit was built by the Matlab programmer for the purpose of evaluating the longitudinal section of the variable flow in a step-by-step method, giving more accurate models at a speed that does not exceed seconds, as long mathematical equations that take a long time to solve have been eliminated. The water surface profile is shown in Figure

5 which was measured along the center line of the channel and represents the relationship between water depth and discharge for eight sections and different channel slopes. Figure 6 shows the water surface profile at different discharges at slope $S_o = 0.003$. The outcomes of the simulations carried out using the numerical model are presented. Figures 7 and 8 represent the outline of the water surface, which shows the difference in height between the two discharges ($0.012 \text{ m}^3/\text{s}$ and $0.035 \text{ m}^3/\text{s}$) using the ANSIS Flow, in addition to the contour lines that represent velocity distribution on the water surface. According to these numbers, there is a good agreement between the results that were predicted and those that were measured, with a percentage error rate of 1.4%. The water surface plans for the two discharges have been combined in Figure 9. It shows the height of water at the upstream and downstream of the weir for maximum and minimum discharge and

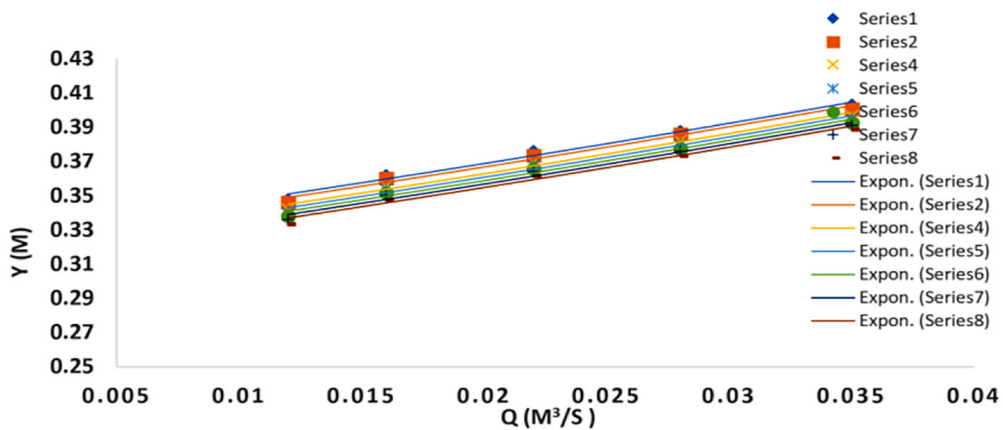

Fig. 5. The relationship between water depth and discharge for eight sections

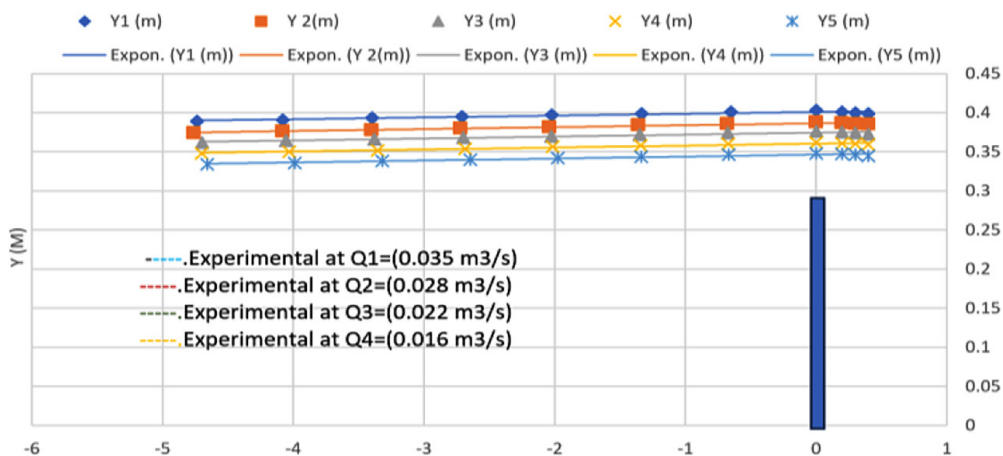

Fig. 6. The water surface profile for different discharges and $S_o = 0.003$

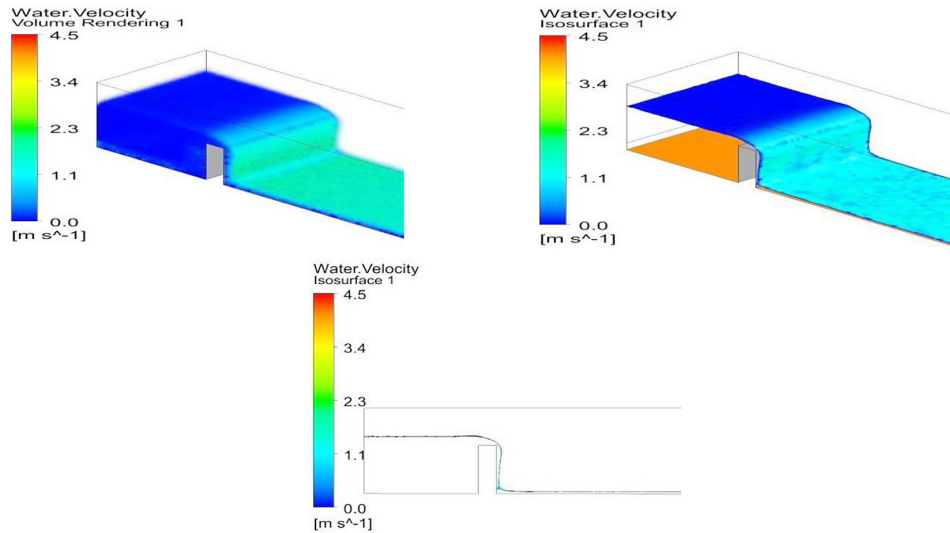

Fig. 7. The contour lines of the velocity distribution on the water surface, which show the flow behavior above and below the weir at $Q = 0.012 \text{ m}^3/\text{s}$

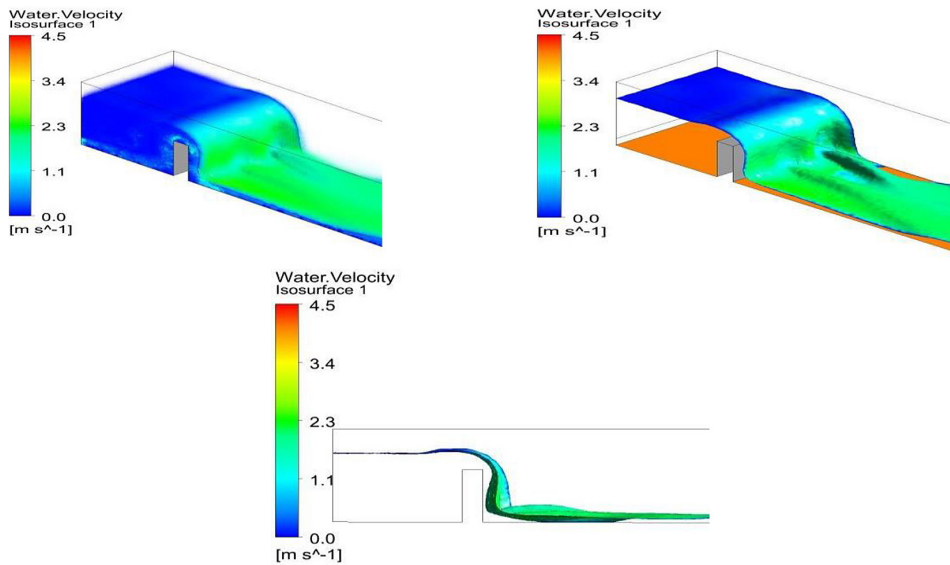

Fig. 8. The contour lines of the velocity distribution on the water surface, which show the flow behavior above and below the weir at $Q = 0.035$

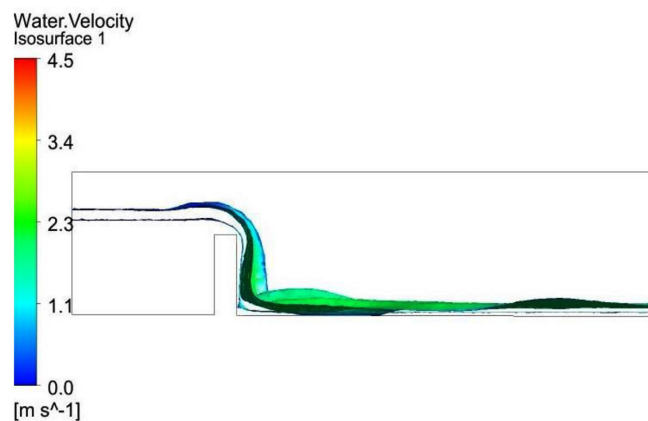

Fig. 9. The height of water at the upstream and downstream of the weir for maximum and minimum discharge

significant change in the surface water profile and flow state from laminar to turbulent.

CONCLUSIONS

MATLAB Simulink can be actually used to assess the longitudinal section of the water surface in rivers and channels. This is done by modelling the flow of water over a long distance, such as in hydraulic structures and analyzing the changes in the height of water along the length of structure. In this study, we used the hydraulic equations that realistically govern flow behavior of water flow. Bernoulli equation and the continuity equation, had been incorporated into Simulink model. Then flow of water through the structure simulated under different conditions, such as varying flow rates or changes in the geometry of the structure. Then the model can be adopted to evaluate the water surface profile along the length of the structure. The results information is considered very important to understanding the water flows through the structure and designing structures that can handle various discharges and water levels. In conclusion, we can say that MATLAB Simulink is a multiuse tool that can be used for a wide range of applications in hydraulic structure research. Throughout what has been discussed, modelling and simulating the behavior of hydraulic structures to estimating the longitudinal section of the water surface, Simulink supports researcher strong and powerful tools for analyzing and resolving these complex systems. It also reveals more accurate and actual results in a short time and low cost.

Acknowledgements

We would like to express our thanks of gratitude to Northern Technical University, Technical College of Engineering in Mosul, for supporting us with a simulation package that allowed us to complete our research.

REFERENCES

1. Al Hashimi, S., Madhloom, H. 2018. Determination of discharge coefficient for broad crested weir. Paper identification.
2. Aydin, M.C. 2012. CFD simulation of free-surface flow over triangular labyrinth side weir. *Advances in Engineering Software*, 45(1), 159–166.
3. Azimi, A.H., Rajaratnam, N. 2009. Discharge characteristics of weirs of finite crest length. *Journal of Hydraulic Engineering*, 135(12), 1081–1085.
4. Daneshfaraz, R., Minaei, O., Abraham, J., Dadashi, S., Ghaderi, A. 2021. 3-D numerical simulation of water flow over a broad-crested weir with openings. *ISH Journal of Hydraulic Engineering*, 27(sup1), 88–96.
5. Fulasa, B.F. 2019. Investigation on different shapes of broad-crested weirs by means of CFD. Master's thesis, NTNU.
6. Hargreaves, D.M., Morvan, H.P., Wright, N.G. 2007. Validation of the volume of fluid method for free surface calculation: the broad-crested weir. *Engineering Applications of Computational Fluid Mechanics*, 1(2), 136–146.
7. Irzooki, R.H., Yass, M.F. 2015. Hydraulic characteristics of flow over triangular broad crested weirs. *Engineering and Technology Journal, University of Technology*, 33(7), 1186–1196.
8. Juma, I.A., Noori, B.M. 2009. Performance improvement of broad crested weirs. *Al-Rafidain Engineering*, 17(2).
9. Kalajdzisalihovic, H., Milasinovic, Z., Harapin, A. 2021. Developing a new weir type using the smoothed particle hydrodynamic model. *Coupled Systems Mechanics*, 10(6), 491.
10. Madadi, M.R., Dalir, A.H., Farsadizadeh, D. 2014. Investigation of flow characteristics above trapezoidal broad-crested weirs. *Flow Measurement and Instrumentation*, 38, 139–148.
11. Mahmoud, A.S., Mezaal, M.R., Hameed, M.R., Naje, A.S. 2022. A framework for improving urban land cover using object and pixel-based techniques via remotely sensed data. *Nature Environment & Pollution Technology*, 21.
12. Mezaal, M.R., Pradhan, B., Shafri, H.Z.M., Mojadadi, H., Yusoff, Z.M. 2019. Optimized hierarchical rule-based classification for differentiating shallow and deep-seated landslide using high-resolution LiDAR data. In *GCEC 2017: Proceedings of the 1st Global Civil Engineering Conference*, 1, 825–848. Springer Singapore.
13. Ayoob, N.S., Hamad, A.M. 2022. Numerical simulation for flow over a broad-crested weir using FLOW-3D program. *Civil Engineering and Architecture*, 10(5), 2157–2171. doi: 10.13189/cea.2022.100534.
14. Naghavi, B., Esmaili, K., Yazdi, J., Vahid, F.K. 2011. An experimental and numerical study on hydraulic characteristics and theoretical equations of circular weirs. *Canadian Journal of Civil Engineering*, 38(12), 1327–1334.

15. Parsaie, A., Shareef, S.J.S., Haghiabi, A.H., Irzoo-ki, R.H., Khalaf, R.M. 2022. Numerical simulation of flow on circular crested stepped spillway. *Applied Water Science*, 12(9), 215.
16. Sameen, M.I., Pradhan, B., Shafri, H.Z., Mezaal, M.R., bin Hamid, H. 2017. Integration of ant colony optimization and object-based analysis for LiDAR data classification. *IEEE Journal of Selected Topics in Applied Earth Observations and Remote Sensing*, 10(5), 2055–2066.
17. Taghavi, M., Ghodousi, H. 2015. Simulation of flow suspended load in weirs by using flow3D model. *Civil Engineering Journal*, 1(1), 37–49.
18. Yuce, M.I., Al-Babely, A.A., Al-Dabbagh, M.A. 2015. Flow simulation over oblique cylindrical weirs. *Canadian Journal of Civil Engineering*, 42(6), 389–407.