SELECTED ENGINEERING PROBLEMS

NUMBER 6

INSTITUTE OF ENGINEERING PROCESSES AUTOMATION
AND INTEGRATED MANUFACTURING SYSTEMS

Andrzej WRÓBEL^{*1}, Wojciech SURMA

¹Institute of Engineering Processes Automation and Integrated Manufacturing Systems
Faculty Of Mechanical Engineering, Silesian University of Technology

* andrzej.wrobel@polsl.pl

TEMPERATURE MEASUREMENT OF DRIVE SYSTEMS WITH INCREASED RESISTANCE TO ELECTROMAGNETIC INTERFERENCE

Abstract: In the paper design of the measurement and diagnostic-based of digital temperature sensors MAXIM DB18B20 was presented. System dedicated for drive systems which generate electromagnetic interference. To build the system computing unit with an open architecture and the recommended software was used.

1. Introduction

One of the basic diagnostic parameters of drive systems is the temperature. The study of this parameter allows identify fault or determine technical condition of the system. Contact temperature measurements of electric motors require sensors with very small dimensions, compact design, resistant to damage and immune to electromagnetic interference. In addition, it is recommended that high measurement accuracy and the lowest temperature inertia [1-6].

2. Function of sensors DB20B18 MAXIM

The main advantages of the system DB18B20 is a digital communication interface with 12-bit resolution. The measuring system can have unlimited number of temperature sensors. This is possible by built individual 64-bit addressing system. One-Wire Interface, based on one line of data, which represents the name of the bus was used. The transmission speed is in the range from 16 kb/s to 142 kb/s. The interface is similar to I2C, but considerably slower. This is due to the lack of the line clock (look fig.1 and fig. 2) . The advantage is the simplicity of implementation and the cost of use. One wire bus is based on the architecture of one master device and multiple slave devices. Low demand for energy, allow to supply system from data line. Each device has a capacitor of 800 pF, which is loaded during the breaks between the transmission data [1,6].

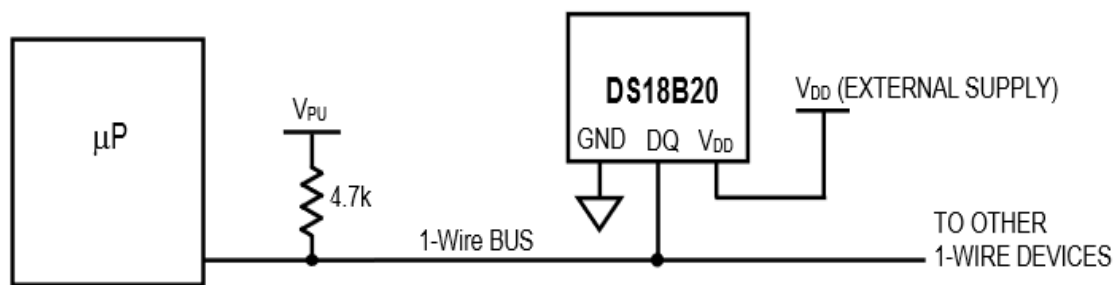

Fig. 1. Diagram of the sensor supply DS18B20 [1]

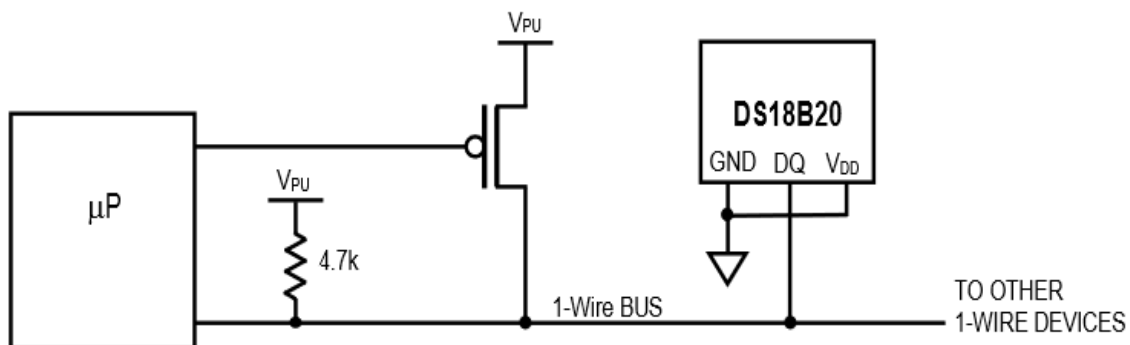

Fig. 2. Scheme of parasitic supply of sensor DS18B20 [1]

Data line interface requires a pull-up resistor at the default value of 4.7 k Ω for supply voltage. This is due to the construction of systems of broadcasting. All transmitters are an open drain or open collector, it gives rise to the so-called product on the wire. High state is recessive and dominant state is low. This enables detection of collision broadcast by various system components. The device giving high state on the bus also checking its status. None of the changes on the line indicates that the other device is in the process of transmission. The bus does not have a strictly defined format for transmission of information, but by default, both through the 8-bit messages (fig. 3) [1,6].

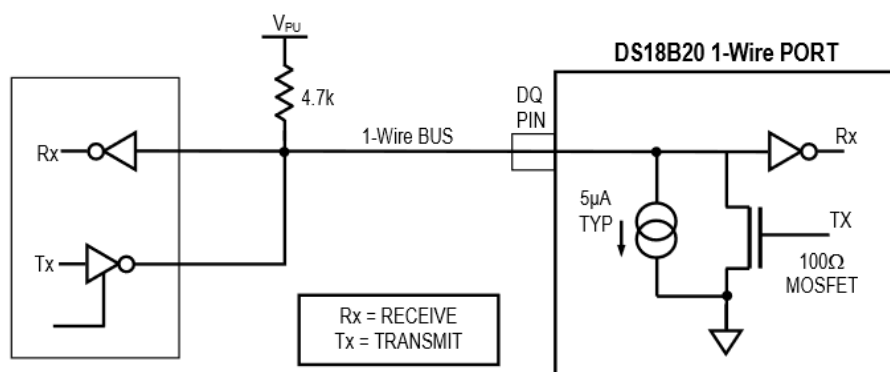

Fig. 3. Diagram of the internal structure of the transmission. [1]

The user has the ability to configure the resolution of the transducer in the range of 9 to 12 bits. This corresponds to a measurement accuracy of 0.5 $^{\circ}$ C, 0.25 $^{\circ}$ C, 0.125 $^{\circ}$ C and

0.0625° C. The increase in the resolution increases the conversion time of which a maximum of 750 ms. The measuring range is in the range from -55°C to 125°C [1].

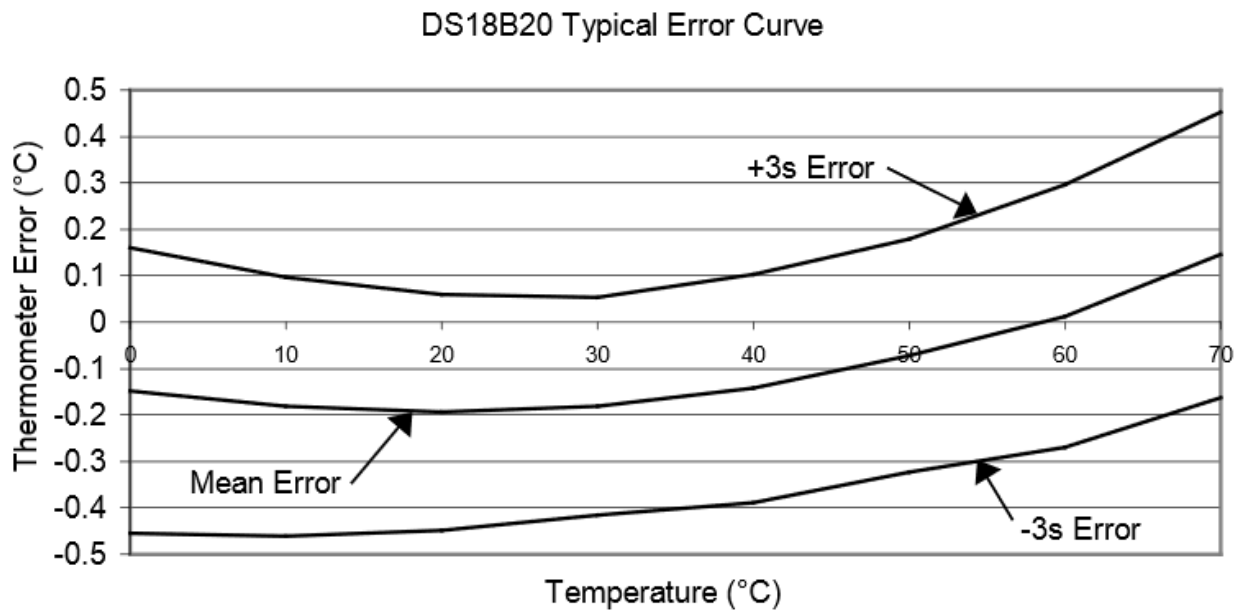

Fig. 4. The impact of temperature for the measurement error [1]

Measurement errors for standard operating conditions powertrain shown in Figure 4. Electromagnetic Interference negative impact on the quality of the data, but does not significantly affect the temperature measurement. This is due to a compact internal structure of the measurement system. Mistakenly data packets caused by interference are repeated. The system does not require the use of length compensation wires connecting the system with a microcontroller [1,6].

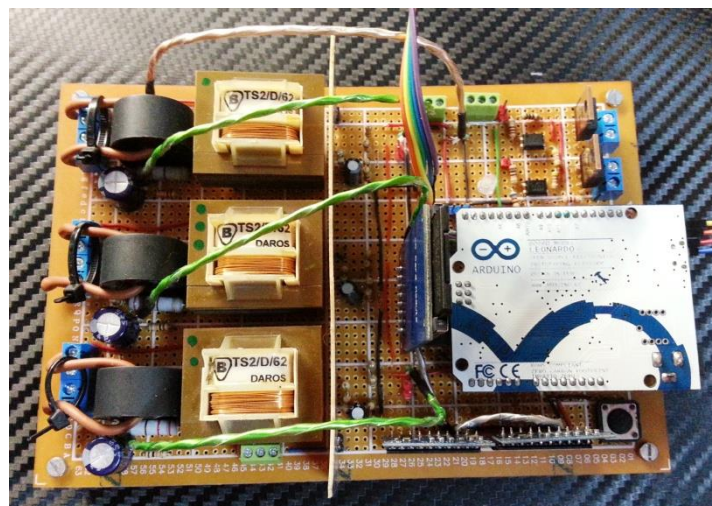

Fig. 5. Measuring system

The system samples the temperature 25 times per second of the four points. The sensors are placed on the body, bearings and motor windings. Data is stored on the SD card as a text file

or sent to a PC via UART interface. Each measurement contains information about the test step, the rotational speed, during operation of the microcontroller and sequentially recorded temperatures. Appropriate formatting stored data can be further processed in programs such as computing Matlab, Scilab or Excel. This makes possible to show temperature characteristics of engines, construction impact on the quality of the cooling fan or determine recommended downtime to cool the system.

It is possible to directly control the two inverters, as the regulation of the load and speed of the drive system. Changes in the values of frequency and modes of operation of the system are held by the analog joystick bi-axial.



Fig. 6. Display of current temperature

Figure 6 shows the view of the display of temperature measurements from four independent sources.

3. Conclusions

The measuring system based on sensors, digital MAXIM DS18B20 has many features that are recommended for measuring drive systems. No analog signals on communications significantly reduces the occurrence of measurement errors caused by electromagnetic interference. This enables temperature measurements motor windings, bearings and motor housings of electrical drive systems. [4-6].

References

1. <https://www.adafruit.com/datasheets/DS18B20.pdf> [20.02.2016].
2. Przyborowski W.: Electrical machines. OWPW. Warszawa 2014.
3. Plamitzer M.: Electrical machines. WNT. Warszawa 1986.
4. PN-EN-06717: Rotating electrical machines.
5. Charoy A.: Interference in electronic devices. WNT. Warszawa 1999.
6. Czaja Z.: Microcontrollers and microsystems. Gdańsk 2015.