

Vibrations produced by petrol chainsaws with variable-length guide bars during cross-cutting

KRZYSZTOF WÓJCIK

Department of Agricultural and Forest Engineering, Warsaw University of Life Sciences – SGGW

Abstract: *Vibrations produced by petrol chainsaws with variable-length guide bars during cross-cutting.* The aim of the study is to compare equivalent values of vibrations measured on the front and rear handles of a portable petrol chainsaw during cross-cutting. The survey encompassed an analysis of the guide bar length impact on vibrations emitted when cutting off individual fragments of the measurement log, with dimensions determined by the length of the guide bar used during cross-cutting, on a dedicated test stand. The measurements carried out also made it possible to establish the daily exposure to vibrations and the admissible operating time resulting from the acceleration of vibrations emitted by the chainsaw with guide bars of different lengths. During the testing, higher vibrations were registered on the rear handle of the saw, with values growing together with the increase of the guide bar length. Performance was higher and work was easier when the guide bars were longer than the diameter of the timber logged, while when the bar lams were shorter, exposure to vibrations decreased proportionally. In all the cases subjected to analysis, the admissible vibration acceleration values were exceeded and need to be limited in an 8-hour working time.

Key words: petrol chainsaw, vibrations, cross-cutting, daily exposure to vibrations, admissible operating work time, surface cutting efficiency

INTRODUCTION

Saw vibrations cannot be fully eliminated and can be only slightly reduced. Therefore, no matter how the timber is obtained, the chainsaw operator is significantly exposed to strong vibrations during wood processing [Pitts et al. 1990, Monarca et al. 2003a, b, Pitts 2004].

Cross-cutting usually occupies 15 to 30% of the overall time of processing of one tree and is performed after the tree has been cut, thrown and lopped. Such an order of operations is typical of the timber acquisition method known as the grading method or the short timber method. Currently, when this method is used, logging is not performed right after each tree has been cut off and lopped, but collectively for several or a dozen or so trees. Therefore, the share of logging in the entire working day can sometimes exceed the previously established levels and take up to 100% of the working time, serving as the main determinant of the operator's exposure to vibrations [Wójcik 2007, Wójcik and Petrów 2013].

Even if the chainsaw operator has two sawing machines, a bigger one and a smaller one, he usually keeps using the bigger one (i.e. the one which he used for tree cutting) for the logging operation, leaving the smaller one for lopping only. If there is only one saw at the operator's disposal, it is used for all three operations. Nonetheless, in both variants (with two chainsaws and with one chainsaw), the length of the bar lam used for the logging often varies.

Delimiting is usually performed with shorter bar lams, which makes it easier both to operate the chainsaw and move around the tree with the saw in the hands. When it comes to tree cutting and logging, in turn, longer bar lams seem better, as they allow more static work, with only slight movements by the tree. Additionally, in this latter case, the efficiency of work grows due to bigger machining performance per area and due to the possibility to log the timber piece making one kerf only, without going to the other side of the tree.

It shows that the factual time of chainsaw operation in the process of logging different timber grades is almost inversely proportionate to the length of the grades produced [Szyber and Wójcik 2007].

The time of cross-cutting depends on the size of the chainsaws used in the process and on the parameters of the trees obtained, including, in particular the number and diameter of the grades produced [Wójcik 2007, 2009].

Based on previous research [Wójcik and Skarzyński 2008, Wójcik 2009, 2012], it can be concluded that together with the growth in the diameter of the wood logged grows the volume of vibrations produced on the chainsaw handles. Similar observations can be made for growing wood thickness [Skarzyński and Wójcik 2008].

Numerous research shows that for the cross-cut kerfing technique, the biggest vibration-related risk occurs if the logging is performed with the bottom side of the bar lam with a felling dog, irrespective of the timber diameter, while the lowest risk occurs when the cutting is done with the bottom side of the bar lam [Pitts et al. 1990, Sowa 1995, 1998, Wójcik and Skarzyński 2008, Rottensteiner and Stampfer 2013].

The most frequent kerfing operations are shown on Figure 1. The figure shows cross-cutting with the bottom side of the guide bar without the bumper spike (Fig. 1a), cross-cutting with the upper

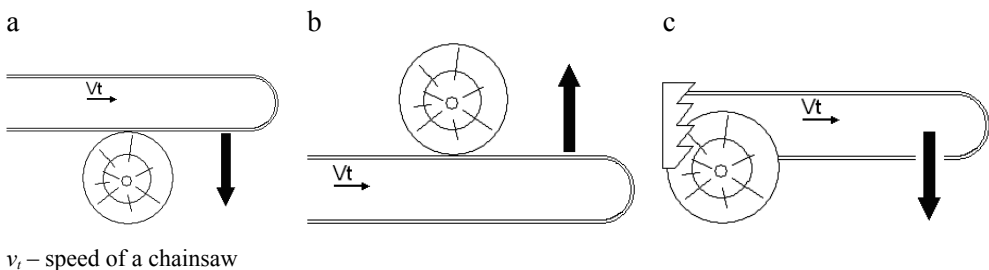

FIGURE 1. Methods of making a cross-cutting: a – the bottom of the guide bar without using a bumper spike, b – the upper side of the guide bar without using a bumper spike, c – the bottom of the guide bar with a bumper spike

side of the guide bar without the bumper spike (Fig. 1b), and cross-cutting with the bottom side of the guide bar with the bumper spike (Fig. 1c).

The aim of the study is to compare equivalent values of vibrations measured on the front and rear handles of a portable petrol chainsaw during cross-cutting.

The survey encompassed an analysis of the bar lam length impact on vibrations emitted when cutting off individual fragments of the measurement log, with dimensions determined by the length of the guide bar used during cross-cutting, on a dedicated test stand, with a view to determining their relevance for the operation.

The measurements also made it possible to establish the daily exposure to vibrations and the admissible operating time resulting from the acceleration of vibrations emitted by the chainsaw with guide bars of different lengths, which can be of use for the operators who are unsure what bar lam to use for the cross-cutting.

MATERIAL AND METHODS

The research was performed on five Stihl MS 250 petrol chainsaws after successful technical inspection. The model

represents medium-sized chainsaws with engine cubic capacity of 45.4 cm³, power of 2.3 kW, maximum torque of 2.6 Nm (2.3 Nm for maximum power) and weight without the bar lam and the saw of 4.6 kg. Idling rotational speed is 2,800 rpm, maximum idling rotational speed is 14,000 rpm (or 10,000 and 7,200 rpm, respectively, for maximum torque and power). According to data provided by the manufacturer, vibrations on handles equal 5.7 m·s⁻² for the front and 6.8 m·s⁻² for the rear handle. Noise level equals 99 dB(A).

The three-part low-profile Rollmatic E guide bars (3/8" P) used with the chainsaw were made of three welded plates, with a star-shaped sprocket and a 1.3-mm wide guiding groove on the nose. The low-profile Pico Super 3 (3/8" P) chain saws integrated with the lams were fitted with chisel links and 1.3-mm wide guiding links. Both the lams and the saws were new and unused. The parameters of the guide bars and chain saws used are shown in Table 1.

The research was performed in measurement conditions consistent with standards PN-EN ISO 22867:2009, PN-EN ISO 5349-1:2004 and PN-EN ISO 5349-2:2004.

TABLE 1. Characteristic parameters of guides bar and the corresponding chainsaw used in the measurements

Parameter	Set				
	12"	14"	15"	16"	18"
Length of guide bar, l_p [cm]	30	35	37	40	45
Weight of guide bar, m_p [g]	450	550	580	600	650
Length of chain saw, l_l [drive links]	44	50	52	55	61
Weight of chain saw, m_l [g]	151	172	180	189	209
Weight of cutting system (chain saw and guide bar), m_{zr} [g]	601	722	760	789	859

Vibration acceleration was measured with the use of the second class integral averaging sound meter by Brüel & Kjær with a dedicated module to assess the impact of vibrations transmitted to the human body through the upper limbs (local vibration measurements), on a measuring plate with suitable testing conditions (level surface; ambient temperature of 10–15°C, measured with a mercurial thermometer; wind speed of 0.5–2.5 m·s⁻¹ measured with electronic Kestrel 5000 weather meter).

The timber used for the research was placed on a dedicated rack in such a way that the geometrical centre of the sample was at the height of 600 ± 10 mm above the surface of the measurement plate which served as the reference level for the proper positioning of the measurement stand. The lower edge of the measurement log was placed more than 30 cm above the reference level, which prevented accidental contact of the guide bars nose with the base, and allowed the operator to comfortably finish the kerf without unnecessary knee bending. The measurement log was installed firmly, in a manner preventing its relocation in the

process of logging. The rack, together with the timber affixed thereto, was placed on a hard, level base preventing its accidental displacement.

Dimensions of the measurement log were consistent with the recommendations of standard PN-EN ISO 5349-1:2004, PN-EN ISO 5349-2:2004 and appropriate for the active length of lam bars used in the chainsaws. According to the standard, the log subjected to machining should have the width of 200 ± 10 mm, and the height of 250 ± 10 mm. After the necessary adjustment (connected with the necessity to choose a log with the l_k appropriate for the width of the l_p – Fig. 2), a log with the width of 190 mm and the height of 240 mm was selected (area of 456 cm²). The machining was performed on air-dry pine timber (prism) with humidity of 14% and 3.5 rings per 1 cm².

Vibrations were measured with the use of piezoelectric vibration sensors with sensitivity of 63.9 mV and frequencies as set forth in PN-EN ISO 22867:2009, placed on chainsaw handles (the front one and the rear one) at the points where they come into contact with the opera-

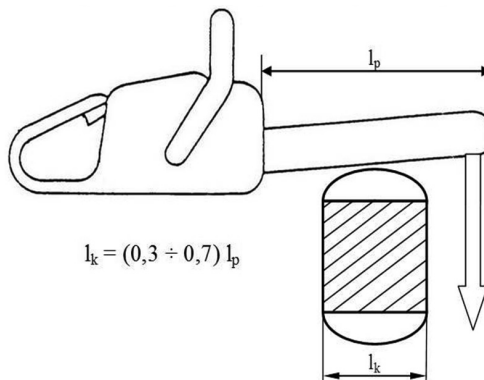

FIGURE 2. Selection of log width (l_k) to length of active guide bar (l_p)

tor's hands, and kept in place for the time of the measurements with the use of a support. The measurement of vibrations on the handles was conducted in three mutually perpendicular directions (x , y , z) defined, according to the standard, as: direction x – parallel to the movement of the chainsaw engine piston, direction y – parallel to the axis of the chainsaw engine crankshaft, direction z – lateral, perpendicular to the plane xy (Fig. 3).

Before beginning each measurement cycle, the following elements were adjusted: carburettor, chainsaw tension, idling speed, gear speed and maximum speed. Fuel and oil tanks were filled up, the engine was warmed-up and the noise meter with the vibration measuring module was calibrated.

The measurement cycle included five measurements for each bar lam length and each chainsaw, the overall time of which did not exceed 120 s; each measurement signal was between 15 and 30 s. The meter was activated and the measurement started (at a stable engine speed of ± 100 rpm) at the start of the cutting-off of the first log section, and was switched off at the end of the cutting-off of the section. Ten slices were cut off during each measurement, with the bar lam kept horizontal at all times, perpendicularly to the log axis, and the kerf was made with the bottom side of the saw, without a felling dog.

The statistical analysis was based on the analysis of the Pearson correlation coefficients and standard deviations of the results obtained. The measurements were carried out with the use of Statistica 12.5 PL software.

Table 2 shows the average equivalent acceleration of vibrations for individual directions (weighted RMS values – a_{eqx} , a_{eqy} , $a_{eqz} = a_{hvx}$, a_{hvy} , a_{hvz}) measured on the handles of the chainsaws evaluated, with bar lams of different lengths, and the weighted RMS value of the vibrations (vector sum of averaging RMS values – $a_{eqSum} = a_{hv,eq}$) calculated on the basis of such averaging values, as well as the permissible working time (t_{dop}) established based thereon. Additionally, Table 2 lists the results of machining performance

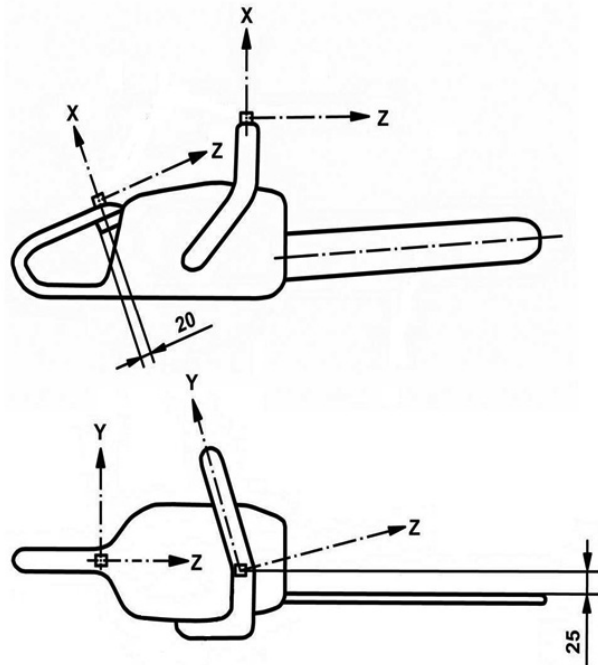

FIGURE 3. Fixing of vibration sensors on the chainsaw handles in three mutually perpendicular directions according to PN-EN ISO 22867:2009

TABLE 2. Vibration measurement results on Stihl MS 250 chainsaw with different length guides bar during cross-cutting (average values) and surface cutting performance

Lenght of guide bar [in·cm ⁻¹]	Handle	RMS for single-axis acceleration value of the frequency-weighted hand-transmitted vibration [m·s ⁻²]			Daily vibration exposure (8-hour energy-equivalent vibration total value) [m·s ⁻²]	Admissible operating work time [min]	Surface cutting efficiency [cm ² ·s ⁻¹]
		a_{eqx}, a_{hwx}	a_{eqy}, a_{hwy}	a_{eqz}, a_{hwz}	$a_{eqSum}, a_{hv,eq}, A(8)$		
l_p						t_{dop}	W_s
12/30	front	3.04	3.34	5.80	7.40	144.8	57.62
	rear	3.98	3.64	7.56	9.28		
14/35	front	3.66	4.24	5.79	8.08	142.4	59.68
	rear	3.92	3.30	7.84	9.44		
15/37	front	4.62	3.48	5.54	8.00	139.3	60.76
	rear	4.08	3.84	7.86	9.65		
16/40	front	4.10	4.38	5.24	7.96	133.1	61.82
	rear	5.82	4.94	6.92	10.10		
18/45	front	4.30	3.74	5.88	8.20	123.3	63.18
	rear	4.60	5.60	7.92	10.90		

per area (W_s), calculated based on the measurements of the logging time. For logging performed throughout the entire shift [with the time of exposure (T_{exp}) of 8 h], the daily exposure to vibrations [$A(8)$], equal to the weighted RMS value of the vibrations [also called equivalent vibrations ($a_{hv,eq}$)], is established according to the following formula:

$$A(8) = a_{hv,eq} \sqrt{\frac{T_{exp}}{8}} \quad [\text{m}\cdot\text{s}^{-2}] \quad (1)$$

For calculations of the permissible time of exposure to vibrations in a working day, the weighted RMS value (i.e. the vector sum from three vibration acceleration directions) to be introduced into formula (2) shall at all times be the highest of all values measured on the front and the rear handle:

$$t_{dop} = 480 \left(\frac{a_{hv,dop}}{a_{hv,eq}} \right)^2 \quad [\text{min}] \quad \text{or}$$

$$t_{dop} = 480 \left(\frac{A(8)_{dop}}{A(8)} \right)^2 \quad [\text{min}] \quad (2)$$

where

$a_{hv,dop}$ is the permitted weighted value of vibration acceleration for a continuous 8-hour exposure (2.8 m·s⁻²), corresponding to the permissible daily exposure to vibrations $A(8)_{dop}$.

RESULTS AND DISCUSSION

The highest vibrations were reported for the direction z (lateral, perpendicular to the plane xy, i.e. parallel to the bar lam on both chainsaw handles). They are

higher than vibrations for other directions by 1.55 to 4.54 $\text{m}\cdot\text{s}^{-2}$. The permissible working time established based on the vibrations obtained varies from 2.4 to 2.0 h.

Figure 4 shows a comparison of averaging results of vibration acceleration measurements during logging for the tested bar lam lengths on both Stihl MS 250 chainsaw handles, with standard deviations marked. Irrespective of the bar lam length, higher vibration values were registered on the rear handle situated along the plane z (from 9.28 for the shortest bar lam to 10.9 $\text{m}\cdot\text{s}^{-2}$ for the longest bar lam). Differences between vibrations on the front and the rear handle equal from 1.36 to 2.70 $\text{m}\cdot\text{s}^{-2}$ for different bar lam lengths and grow with the growth of the bar lam length. Standard deviations for vibrations on the front handle varied from 0.125 to 0.192 $\text{m}\cdot\text{s}^{-2}$, which is 1.55 to 2.34% of the average value of vibrations. For vibrations on the rear handle, the standard deviation was slightly higher and ranged from 0.138 to 0.234 $\text{m}\cdot\text{s}^{-2}$, i.e. from 1.46 to 1.89% of the average value of vibrations.

The impact of the guide bar length and weight of the cutting unit is shown

on Figures 5 and 6. In both cases the acceleration of vibrations produced on fuel chainsaw handles depends on the length and weight of the guide bar used increased by the weight of the chain saws installed thereon. With the significance $p = 0.05$ and $n = 25$, the critical value of the Pearson correlation coefficient equalled 0.3960. For the mathematical regression models of acceleration of the vibrations produced by the guide bar, the correlation coefficients are much higher for both the front and the rear handle and equal 0.8248 and 0.9480, respectively. The dependency between the vibrations on chainsaw handles and the weight of the cutting unit is expressed by the correlation coefficient exceeding 0.8800 and equals 0.8983 for the front and 0.8829 for the rear handle. Therefore, the longer the guide bar and the heavier the cutting unit, the bigger the acceleration of vibrations produced by the petrol chainsaw on the handles and, thus, on the chainsaw operator's knees.

Together with the increase of the guide bar length, the cutting efficiency per area grew almost linearly (Fig. 7). When the logging was performed with the shortest guide bar (12 in), performance equalled

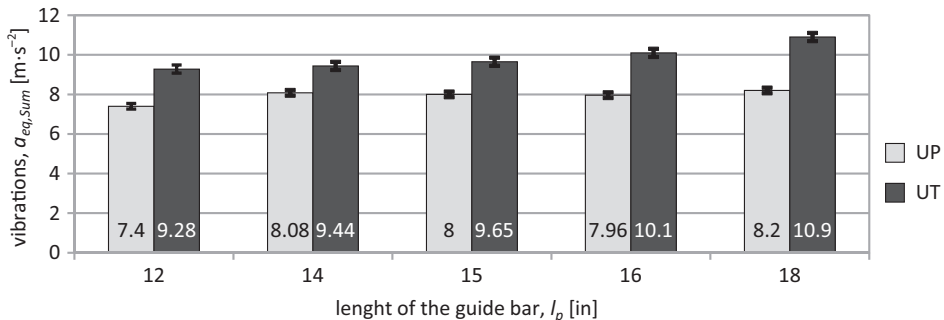

FIGURE 4. Comparison of the results of vibrations measurements during the cross-cutting for all tested guide bars lengths on handles Stihl MS 250 chainsaw, UP – front handle, UT – rear handle

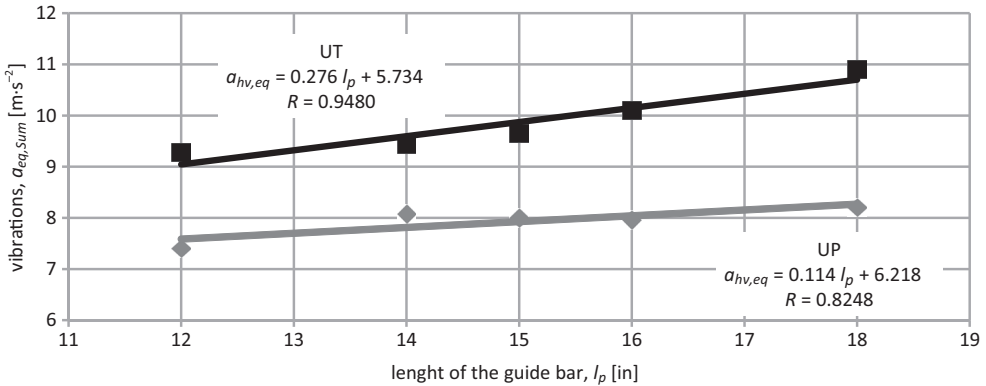

FIGURE 5. Influence of guide bar length on vibrations of the Stihl MS 250 chainsaw on the front and rear handle during cross-cutting, UP – front handle, UT – rear handle

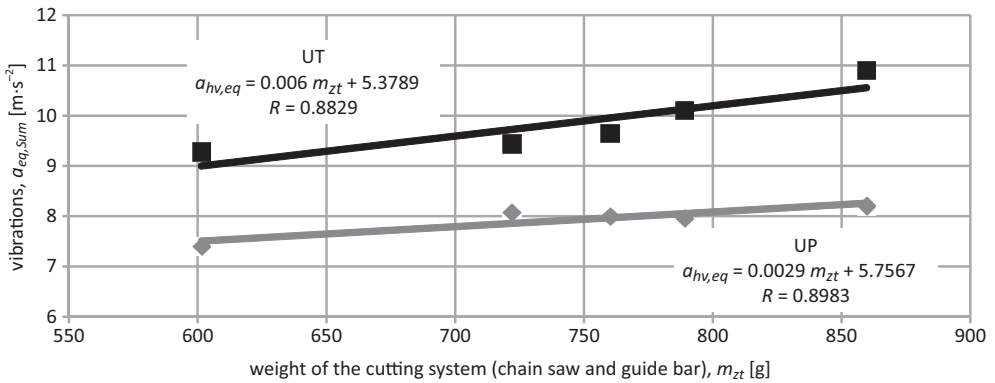

FIGURE 6. Influence of cutting system weight on vibrations of the Stihl MS 250 chainsaw on the front and rear handle during cross-cutting, UP – front handle, UT – rear handle

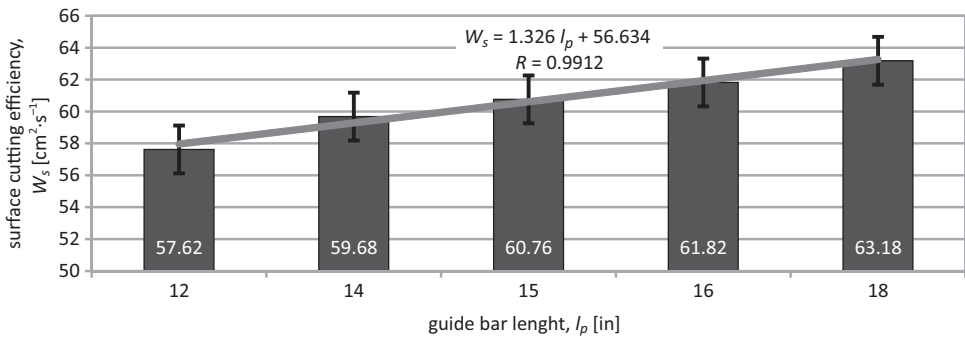

FIGURE 7. Influence of the guide bar length on the surface cutting efficiency during cross-cutting of the measuring log with the Stihl MS 250 chainsaw

57.62 $\text{cm}^2\cdot\text{s}^{-1}$ and grew to 63.18 $\text{cm}^2\cdot\text{s}^{-1}$ for an 18-inch lam bar. The correlation coefficient of the cutting efficiency per area compared to guide bar length was equalled 0.9912, which shows a very strong dependency between the values analysed. Similar effects were obtained in tests carried out by Bieńkowski [1993] and Maciak [2000, 2004].

Cross-cutting entails numerous risks for the chainsaw operator, due to the vibrations emitted, but also because of the noise, exhausts, kick-backs, or risks related to cutting tensioned log sections and considerable physical strain [Sowa 1995, Skarżyński and Wójcik 2008, 2009, Wójcik 2012].

The average time of final crop cross-cutting can take up to 30% of the overall time for the whole processing of each tree, or even reach 100% in extraordinary cases [Wójcik 2007, Wójcik and Petrów 2013]. The quickly accelerating vibrations produced in the operation, from 4 to 15 $\text{m}\cdot\text{s}^{-2}$, grow together with increase of the diameter of the bolt sections cut [Monarca et al. 2003a, Pitts 2004, Wójcik 2009], thus reducing the safe time of exposure to vibrations during the working shift, which, for continuous vibrations, equals from 18 to 235 min.

Values of chainsaw operation reducing the harmful effect of mechanical vibrations vary from 31 to 287 min, for exposure to vibrations during a working shift (i.e. factual logging time), 286 min for clear-cut and 325 min for late thinning. Irrespective of the values specified for both cases, opinions are convergent that in older class tree stands, the values of chainsaw vibrations are higher than for younger tree stands.

What also counts is the technique of kerfing in the process of cutting individual grades, in which case the cross-cutting of wood with diameter lower than 15 cm with the bottom side of the guide bar entails lower risk related to vibrations that when the cutting is made with the bottom side with a bumper spike. For wood with diameter bigger than 15 cm, cutting should be made with the upper side of the guide bar, as this produces lower vibrations [Wójcik and Skarżyński 2008].

SUMMARY AND CONCLUSIONS

The method of assessment of vibrations emitted by chainsaws during cross-cutting presented in the study, which takes into account differences in guide bar length, facilitates decision-making in the process of selection the appropriate set for the operation, in such a way as to minimise the impact of vibrations.

The following conclusions have been drawn from the study:

- during the cross-cutting, higher vibrations (from 1.36 to 2.7 $\text{m}\cdot\text{s}^{-2}$) were registered on the rear handle of the chainsaw, with values growing together with increase of the guide bar length and weight of the cutting unit (guide bar and chain saw);
- the most favourable results, in terms of vibration-related risk, were obtained with the use of chainsaw with a 12-inch long guide bar with slightly worse values reported for the 14-inch long guide bar, recommended by the producer;
- to obtain the expected machining cutting performance, the length of the guide bar should be adjusted to the

- diameter of the timber sections logged and the chainsaw engine parameters;
- the use of guide bars that are longer than the diameter of the timber cut produces better results and significantly facilitates work, but when shorter guide bars are used, the operator's vibrations exposure is lower;
 - the vibration acceleration results obtained in the study differ significantly from the data provided by the producer and are not safe for a 8-hour working time (no matter what option was chosen), with the only way to protect the operator against vibrations being reduction of the time of chainsaw operation.

REFERENCES

- BIEŃKOWSKI J. 1993: Wpływ stopienia ostrzy tnących na opory i wydajność skrawania piłą łańcuchową. *Przegl. Tech. Roln. Leś.* 12: 17–20.
- MACIAK A. 2000: Effect of wear of saw chain cutters on the rate of wood cutting. *Ann. Warsaw Agricult. Univ., Agricult.* 36: 21–26.
- MACIAK A. 2004: Influence of inclination angle of horizontal cutting edge of the chain saw link on cutting effects. *Ann. Warsaw Agricult. Univ., Agricult.* 45: 47–51.
- MONARCA D., CECCHINI M., VASSALINI G. 2003a: Hand-transmitted vibrations: reference standards for chainsaws. *Rivista di Ingegneria Agraria* 1: 45–52.
- MONARCA D., CECCHINI M., VASSALINI G. 2003b: Vibrations transmitted to hand-arm by the main chainsaw models sold in the Italian market. *Rivista di Ingegneria Agraria* 1: 53–64.
- PITTS P.M. 2004: Hand-arm vibration emission of chainsaw – comparison with vibration exposure. *Human Factors Group, HSL Internal Report.*
- PITTS P.M., JONES W., HODGES J., HEWITT S. 1990: Vibration exposure from chain saws. Parts 1–4. HSE, RLSD Internal reports.
- PN-EN ISO 22867:2009. Procedura badania drgań maszyn ręcznych napędzanych silnikiem spalinowym. Drgania na uchwytach.
- PN-EN ISO 5349-1:2004. Drgania mechaniczne. Pomiar i wyznaczanie ekspozycji człowieka na drgania przenoszone przez kończyny górne. Część 1. Wymagania ogólne.
- PN-EN ISO 5349-2:2004. Drgania mechaniczne. Pomiar i wyznaczanie ekspozycji człowieka na drgania przenoszone przez kończyny górne. Część 2. Praktyczne wytyczne do wykonywania pomiarów na stanowisku pracy.
- ROTTENSTEINER Ch., STAMPFER K. 2013: Evaluation of operator vibration exposure to chainsaws equipped with a Kesper safety bar. *Scand. J. Forest Res.* 28: 193–200.
- SKARŻYŃSKI J., WÓJCIK K. 2008: Wpływ twardości drewna na poziom drgań uchwytów pilarki spalinowej podczas przerzynki. In: *Inżynieria Rolnicza. Komitet Techniki Rolniczej PAN, Polskie Towarzystwo Inżynierii Rolniczej, Kraków: 345–351.*
- SKARŻYŃSKI J., WÓJCIK K. 2009: Ocena zagrożenia hałasem operatora pilarki spalinowej podczas okrzesywania i przerzynki. *ZPPNR* 543: 309–318.
- SOWA J.M. 1995: Badania nad określeniem modeli funkcji stanu zagrożeń od drgań pilarek spalinowych w procesie pozyskiwania drewna. *Zesz. Nauk. AR w Krakowie, Rozprawy* 205.
- SOWA J.M. 1998: Analiza zagrożeń wibracyjnych operatorów pilarek spalinowych. *Zastosowania Ergonomii* 3: 189–196.
- SZTYBER J., WÓJCIK K. 2007: Analysis of chain saw operational time during cross-cutting of pine bolt assortments. *Ann. Warsaw Univ. Life Sci. – SGGW, Agricult.* 50: 65–69.
- WÓJCIK K. 2007: Analysis of processing operation time and its percent share in timber harvesting with the chain saws. *Ann. Warsaw Univ. Life Sci. – SGGW, Agricult.* 50: 71–77.
- WÓJCIK K. 2012: Wpływ wielkości pilarki spalinowej i długości jej prowadnicy na wielkość drgań emitowanych podczas okrzesywania. *Nauka Przyroda Technologie, Leśnictwo* 6 (2): 1–10.
- WÓJCIK K., PETRÓW A. 2013: Effect of sawmen's professional experience on working time structure in pine-timber harvesting under conditions of the clear felling. *Ann. Warsaw Univ. Life Sci. – SGGW, Agricult.* 61: 65–72.

WÓJCIK K., SKARŻYŃSKI J. 2008: Wpływ techniki pracy przy przerzynce drewna na drgania i siły na uchwytach pilarki spalinowej. In: Inżynieria Rolnicza. Komitet Techniki Rolniczej PAN, Polskie Towarzystwo Inżynierii Rolniczej, Kraków: 425–431.

Streszczenie: *Drgania emitowane podczas przerzynki przez pilarkę spalinową z prowadnicami o różnej długości.* Celem opracowania jest porównanie wartości ekwiwalentnych przyspieszenia drgań mierzonych na przednim i tylnym uchwycie przenośnej pilarki z silnikiem spalinowym podczas wykonywania przerzynki. Badania obejmują poznanie wpływu długości prowadnicy na wielkość emitowanych wibracji przy odcinaniu fragmentów kłody pomiarowej o wymiarach determinowanych długością prowadnicy zastosowanej podczas wykonywania operacji przerzynki na specjalnie do tego celu skonstruowanym stanowisku testowym. Przeprowadzone pomiary pozwalają równocześnie na możliwość wyznaczenia dziennej ekspozycji na drgania i tzw. dopuszczalnego czasu pracy wynikającego z określonej wielkości emitowanego przyspieszenia

drgań przez pilarkę wyposażoną w prowadnicę o różnej długości. W wyniku przeprowadzonych badań większe wartości drgań zarejestrowano na tylnym uchwycie badanej pilarki, a ich wartość rośnie wraz z długością prowadnicy. Stosowanie prowadnic o długości większej niż średnica przerzynanego drewna pozwala na uzyskanie większej wydajności i znacznie ułatwia pracę. Przy stosowaniu krótszych prowadnic narażenie na drgania jest odpowiednio mniejsze. We wszystkich analizowanych przypadkach stwierdzono przekroczenie wartości dopuszczalnej przyspieszenia drgań, co przy 8-godzinnym czasie pracy wymaga jego ograniczenia.

MS received October 2017

Author's address:

Krzysztof Wójcik
Wydział Inżynierii Produkcji SGGW
Katedra Maszyn Rolniczych i Leśnych
02-787 Warszawa, ul. Nowoursynowska 164
Poland
e-mail: krzysztof_wojcik@sggw.pl