

Classics of Polish Design. Józef Chierowski's "Armchair 366" from 1962 as an icon of design from the Polish People's Republic

LUDWIKA KUJAWA ¹, ANNA ROZANSKA ²

¹Faculty of Wood Technology, Warsaw University of Life Sciences WULS-SGGW, Poland

²Department of Technology and Entrepreneurship in Wood Industry, Institute of Wood Sciences and Furniture, Warsaw University of Life Sciences WULS-SGGW, Poland

Abstract: *Classics of Polish Design. Józef Chierowski's "Armchair 366" from 1962 as an icon of design from the Polish People's Republic* presents a classic of Polish furniture design from the post-war "modernity" period. We analysed the style, structure, and functionality of this armchair, evaluating it in comparison to other Polish and foreign modern furniture designs for small apartments. The paper aims to provide a substantial analysis of the reasons for the armchair's exceptional popularity in contemporary pop culture, contributing to the series "Classics of Polish Design" that presents the results of research on Polish furniture and the icons of Polish design, carried out within the framework of dissertations in the Department of Wood Technology in the Warsaw University of Life Sciences (SGGW).

Keywords: Józef Chierowski, "Fotel 366/Armchair 366", Polish post-war furniture, 1950s and 1960s design, furniture for small apartments, "modernity", social housing, IWP, Bauhaus, Scandinavian design

1. INTRODUCTION

The post-war period in Poland was a time of huge social transformations, leading to a revolution in the organisation and layout of residential interiors. It was a time of bridging the social gaps and providing universal access to education.

The pre-war idea of designing apartments for the working class and social housing was extended to the intelligentsia and bourgeoisie. After the war, social housing developments designed by members of the artistic avant-garde started to be built in large numbers, in order to satisfy all human needs: the need for privacy, as well as social needs. Privacy was ensured by giving them an individual – although small – flat with a kitchen (which was a new standard comparing to times before the war), and with a private bathroom, although the function of washing and drying clothes was often carried out in laundry rooms shared by the entire settlement. Social needs were addressed by clubs, community centres, libraries and even a local cinema. The tenants of the social housing estate brought their kids to local kindergartens, used the services of local workshops (e.g. the cobbler) and small local shops (bakery, dairy and butcher's stores) within the settlement, only travelling to downtown Commercial Centres for more significant shopping.

Households no longer employed maids, so wives and mothers had to do all the cooking in the Polish version of the "Frankfurt kitchen" designed for them.¹

¹The "Frankfurt kitchen" was an innovative, ergonomic kitchen design created in 1927-1928 by the German architect Margarete Schütte-Lihotzky for workers' housing estates in Frankfurt am Main. The furniture set was designed for a small interior of 1,9 x 3,4 meters, with a window on its shorter wall and a working countertop below it, and a stool (location that provided appropriate lighting in daytime with the option to work while seated). The countertop had an opening and a sliding drawer for trash below it. When the countertop was not being used for kitchen work, a hinged ironing board – fixed to the wall slightly above – could be unfolded and placed on top of it. Along the longer wall on the left, there was a modern (at that time) gas cooker and dish heater; and on the right, a metal sink and a dish rack. The layout of individual zones in the kitchen was in line with the so-called ergonomic triangle that still remains valid. The kitchen was equipped with a row of hanging cupboards with glass doors, hanging above the sink, and racks with additional sliding work surface countertops and easily accessible bulk



Figure 1. Dining set [Zjednoczenie Przemysłu Meblarskiego 1960]

The number of meters per person had been limited (the living standards for M-1, M-2, M-3, etc.), so it was necessary to design new kind of furniture. The large, expensive furniture sets for dining rooms, offices and bedrooms did not fit in the newly built small apartments. Therefore, they needed to be redesigned, and furniture sets were often replaced with single, multi-functional pieces of furniture, like the highly popular coffee table (Fig. 1), whose height was adjusted to either chairs and high armchairs, or lower armchairs and sofas.



Figure2. Coffee tables [Meble do Małych Mieszkań 1966]

Small apartments required small, multifunctional, and lightweight furniture that could be shifted from place to place and adapted to different functions. Good availability of new materials such as plywood, metal, and plastic, as well as new technologies and the social need

product drawers made of aluminium. Ergonomic handles and labels on the drawers made it easier to organise work in the kitchen.

for modern style, all contributed to formal experiments (Róžańska et al. 2021a). The price of furniture did not make it possible to furnish the entire apartment at once. Therefore, furniture was designed to fit each other, even if it was designed by a different person and produced by a different production plant, at a different time. In the 1950s and 1960s, the offer of available furniture in the market grew significantly, and the development of industrial production initiated a new creative branch: industrial design, together with the profession of industrial designers who were employed by production plants. Moreover, professional institutions were created to deal with broadly understood design (Like the IWP – Institute of Industrial Design in 1950, or Design Faculties at Academies of Fine Arts), inspiring designers, providing a scientific, technical, and material base for them, and conducting research, monitoring, and consulting. The Council of Design and Aesthetics in Industrial Production was founded at the Chancellery of the Prime Minister (Swaczyna 1990).



a



b



c



d

Figure 3. Modern furniture designs: Little Shell chair by Teresa Kruszevska from 1965 (a) [Kozina 2015], upholstered armchair by Maria Chomentowska from 1957. (b) [Kozina 2015] chair "Pająk" ("Spider") from

1956 designs by Maria Chomentowska (c) [<https://wyborcza.pl>] and the “Armchair 366” by Józef Chierowski (d) produced from 1962 [<https://www.wikipedia.org>]

The style of Polish “modernity” used trapezoid and parabolic shapes, references were made to organic abstraction, furniture legs were designed as tapering downwards, and their span often stretched outward like the legs of a compass (Fig. 3) (Kozina 2015). Modern furniture was popularised by national furniture expos, photo albums, or interior columns in daily press (Fig. 1-2), and the style of residential interiors was perceived by the most part of society at that time as either progressive or obsolete.

Formally, modern Polish furniture from the 1950s and 1960s did not differ from global design trends in terms of quality or style. They continued the exquisite tradition of Polish applied arts from the interwar period (Kostrzyńska-Miłosz 2005), initiated by the high quality crafts from the turn of the 20th century (Huml 1978). Produced mainly of wood, nicely finished with glossy French polish, complemented with plywood fittings, they also contained laminated plastic elements with vivid colours: blue, green, red; as well as black countertops or recesses. Polish textile design flourished in the years after the war, translating into beautiful furniture upholstery. Furniture from that period was formally interesting and often made use of original construction designs.

Perhaps this is the reason why Polish “modernity” style from the 1950s and 1960s is gaining popularity in contemporary interior design [Różańska al.2021b]. The rekindled interest in the Polish People's Republic refers mainly to furniture, with an increase of popularity of the chairs, armchairs and tables designed in that period, which are being used in contemporary atmospheric designer's interiors. They are relatively cheap (a set of 6 chairs costs about 3500 PLN, and a cupboard ca. 500 PLN), universally available (because they were mass produced in the 1960s and 1970s), and relatively durable (which explains the large quantity of pieces preserved until today). Some time ago they were being saved from trash containers by a few enthusiasts, today they are sought-after, fashionable, and are entering pop culture – as people get tired with the impersonal interiors created by international design. Due to their universal availability and relatively low price, they often fall victim of unprofessional, botched restoration efforts that do more harm than good, obfuscating or even completely destroying their unique value. This phenomenon is gaining intensity, so it definitely requires attention and a wider commentary from the scientific community devoted to studying post-war Polish furniture design.

2. RESEARCH AIM, SCOPE AND METHODOLOGY

The aim of this paper is to provide a detailed presentation of an icon – a classic of design from the Polish People's Republic – “Fotel 366/Armchair 366” (Fig.3c), designed by Józef Chierowski, and currently gaining popularity in the second-hand furniture market in Poland. The paper presents the armchair’s characteristics in comparison with other post-war pieces of furniture in Poland, Scandinavia, and the Bauhaus school, analysing its style, structure, and functionality. In our search for the reasons of the growing popularity of this armchair in the market of revitalised, second-hand furniture, we also analysed its innovativeness and timelessness in the context of Polish furniture for small apartments and the typical stylistic features from the period of modernism in the 1950s and 1960s.

The characteristic of post-war Polish furniture was based on reference literature. The author's biographic data were taken from the literature and a documentary movie. The style of the “Fotel 366/Armchair 366” was characterised on the basis of comparisons with other pieces presented in specialist reference literature about design, as well as Internet sources and catalogues of exhibitions from the period. The structure and materials were characterised on the basis of macroscopic study of several pieces of the armchair. Style, structure, functions, and comparison with other post-war furniture pieces for small apartments were analysed on the

basis of literature and illustrations available in publications and on the Internet. The timeless character of "Fotel 366/Armchair 366" was analysed on the basis of the author's own research, including the review of its restoration and revitalisation proposals encountered in online sources.

3. CHARACTERISTICS OF "FOTEL 366/ARMCHAIR 366"

3.1 Józef Marian Chierowski – designer of "Fotel 366/Armchair 366"



Figure 4. Józef Chierowski [<https://www.yestersen.com>]

Józef Marian Chierowski (Fig.4) was born in 1927 and died in 2007. He was a designer of interiors, furniture and pianos, who cooperated with the Lower-Silesian Furniture Production Plant in Świebodzice, as well as the Musical Instruments Production Plants in Kalisz and Legnica. In 1952, Chierowski graduated from the Faculty of Interior Design at PWSSP in Wrocław, whose dean at that time was Władysław Wincze. Wincze was one of the most famous independent Polish interior designers from the interwar period and remained professionally active in the post-war times – so it is not surprising to find his influence in Chierowski's own work. After graduating, Chierowski stayed in his alma mater as an employee of the Faculty of Design, and in 1976 became its chief – a function he carried out until the end of 1980. This is where, together with Piotr Karpiński, he headed the Furniture Design Studio. Moreover, he was an active designer for the "Miastoprojekt" enterprise in Wrocław and Kalisz, designing interiors for the Regional Public Library, ZETO and the Trauma Surgery Clinic of the Medical Academy. In 1960, he received a prize from the Design Council for his numerous furniture designs, and in 1974 the "Miastoprojekt" award [Kozina 2015].

The "Fotel 366/Armchair 366" was created in 1962 and produced in the 1960s by the Lower-Silesian Furniture Production Plant in Świebodzice (until 1970), the Głuchołazy Furniture Production Plant in Głuchołazy, as well as the Furniture Industry Centre in Świdnica (since 1970). The exceptional history of this piece of furniture starts precisely at the Lower-Silesian Furniture Production Plant in Świebodzice (known as the Świdnickie Fabryki Mebli before 1975). The 1962 fire that destroyed the plant's machinery based on obsolete technologies, paradoxically created an opportunity to equip it better for more modern designs. Chierowski proposed an armchair that was going to satisfy the needs of all stakeholders [<https://vod.tvp.pl>]: on the one hand, the interests of the production plant (that wanted to

produce high amounts of furniture in a short time), and on the other hand – the needs of the consumers (who wanted cheap, durable furniture with attractive design and modern style).

3.2. Analysis of the armchair's style, structure and functionality

The "Fotel 366/Armchair 366" designed by Józef Chierowski is characterised by minimalistic, modern and dynamic forms. In the 1960s, Polish designers were fascinated by the style of modernism that preferred visually light, rounded, geometrical shapes in furniture-making (also triangular and oblique). The demand for this kind of furniture designs was very high, but the availability caused problems (due to the amounts produced and high prices). Therefore, apartments often had to make do with furniture sets composed of random pieces bought at different times, so a uniform, modern style permitted to maintain a coherent style and function of all those pieces. The "Fotel 366/Armchair 366" by Józef Chierowski was included in the catalogue as a single complementary furniture piece (complementary pieces included all chairs, armchairs, sofas, desks and coffee tables (Meble do Małych Mieszkań 1966). It fitted many furniture sets and was a universal piece to complement the furnishing of residential and office interiors.

The Institute of Industrial Design (IWP), that coordinated industrial production, forced the designers to follow certain rules for maximum functionality. "Fotel 366/Armchair 366" is a perfect design for industrial production, masterfully combining the requirements of demand with the expectations of the suppliers, which made it into one of the best-known symbols of the Polish People's Republic. It was created as highly functional and aesthetic, which satisfied the consumers. Thanks to its small dimensions and simple structure (or even austerity) it did not take up too much space and did not dominate it, which made it a perfect addition to small residential interiors, as well as public spaces such as the cafeteria [<https://vod.tvp.pl>]. Its simple structure permitted easy and cheap production, thanks to which a high number of pieces could be produced in a short time. The production was easy, most of all, due to the creative and simplified armchair construction.



Figure 5. Wooden frame of the supports and the upholstered part with structural nodes marked [<https://www.loftdizajn.pl>]



Figure 6. Layers of upholstery of the "Fotel 366/Armchair 366"

The armchair, in spite of the fact of being upholstered, has a very light, wooden frame structure. It's not big: 750 mm high, 640 mm wide, and 680 mm deep, with the height of the seat reaching 420 mm. The armchair has a frame structure with two lateral supports, with a very creative and material-effective layout. Technically, it is made of only 2 subcomponents: a frame

made of two lateral supports (connected by aprons in the front and in the back) and the seat resting on transverse braces, integrated with the back, with upholstery on a wooden frame (Fig.5). The seat integrated with the back, visually seems to be hanging between the two lateral supports, to which it is fixed with 4 screws ($\varphi=10$ mm and 70 mm long), 2 on each side. The screws, with large, hemispherical heads, were widely available in the market, because they were used to assemble toilets. Some of them had screws with brass-coated heads, which made them more luxurious.

Each stand (lateral support) is made of 3 wooden elements: 2 oblique legs that get closer to each other in their upper part and connect to horizontal armrests, significantly above the level of the seat. The oblique elements of the stands acted as legs in the bottom part, while in the top part they served as armrest supports. Structurally, the lateral stands are connected to horizontal armrests, and additionally stabilised by the above-mentioned screw connections with the wooden frame of the seat. The presence of screws is used creatively and economically, to assemble the upholstered part and at the same time make the stand structure more rigid. The legs, tapering downwards, are made of wooden beams with rectangular cross-section, which underlines the light and dynamic character of the structure. The rails of the armrests were made of almond-shaped, rounded planks, with slots on the bottom part, one for each of the legs that connect with them via rounded dowel pins with the dimensions of 20 x 29 x 45 mm (Fig.7). As mentioned above, the stands were made of solid wood: depending on the individual piece, it could be beech, oak, or ash. The visible parts of the stands were finished with transparent, glossy shellac or nitrocellulose lacquer, or with a glossy black paint that completely covered the pattern of the wooden structure [<https://www.cotozafotel.pl>].

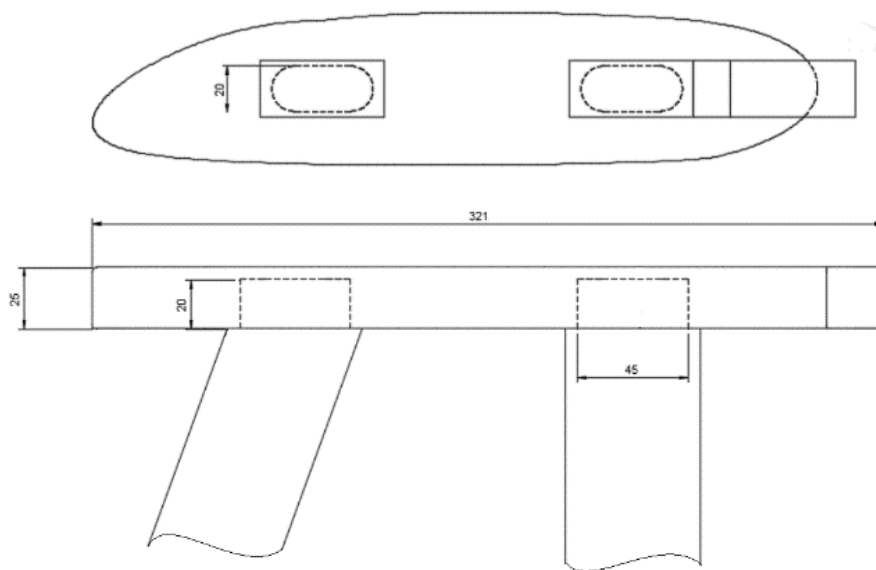

Figure 7. Connection of the horizontal armrests with the legs (a – view from the bottom, b – view from the side)

The frame was used for suspending upholstery, plastically built of two trapezoidal parts, softly connected at an obtuse angle, creating the above-mentioned integrated seat. It is quite cohesive and not too big, so the entire armchair is compact and occupies little space. The upholstered part was installed on a wooden frame (Fig.5). The seat is made of two lateral frame elements, as well as one in the front and one in the back, and the back of the armchair is made of two vertical pieces and the upper horizontal rail. The back rail of the seat is also the bottom horizontal rail of the back. The lower horizontal rail of the back/the back rail of the seat, as well as the vertical stiles of the back, are connected with the use of perpendicular comb joints and ordinary nails with a round section of $\varphi=3$ mm. On the other hand, the top horizontal rail of the

back is connected to the vertical stiles with two dowel pins and an ordinary nail with a round section of $\varphi=3\text{mm}$. The length of the nails was not determined, because they were not removed from the frame. The connective rails of the seat are connected with each other via hidden dowel pins. The wood used for the seat frame is pine and oak.

The layout of upholstery layers in the "Fotel 366/Armchair 366" is traditional [Grzeluk 1998]. The supporting layer is made of 11 upholstery bands in total (6 that support the lower part of the seat, and 5 supporting the back). The armchair does not have a layer of springs, and the seat is made of porous rubber and nonwoven fibre fabric (Fig.6). The upholstery was made of textile dedicated for this purpose from the epingle group, with a thick weave and intense, but uniform colour. Upholstery layers in the part of the back were connected by buttons in an interesting layout: 2 at the top and 1 at the bottom.

In spite of its mass production, the "Fotel 366/Armchair 366" was made of good quality materials. Structural elements of the frame were made of solid wood (beech, oak, ash), and the upholstery was covered with a wear-resistant textile with a decorative weave pattern (light in colour if the legs were black, and darker if the legs retained the colour of wood). Thanks to the materials used for the production of this armchair, it was extremely durable and many pieces have been preserved until today in a very good condition.

Both subcomponents of the armchair (wooden frame and upholstered seat integrated with the back) were made and finished independently from each other. In the production plant's warehouses, the seats could be stored on top of each other (stacked) and the flat frame subcomponents (before joining them with transverse rails) did not occupy too much space. The assembly was also very simple. Apart from the upholstered integrated seat, one needed only two lateral stands, 2 connective rails and 4 widely available screws. And although the armchair was sold in its assembled version, theoretically it could have been assembled by unqualified users with the help of very simple tools (e.g. glue and a screwdriver).

3.3. "Fotel 366/Armchair 366" compared to other modern furniture from the 1950s and 1960s



Figure 8. Scandinavian armchairs by Hans J. Wegner: armchair made of solid wood and plywood (a) [<https://www.catawiki.pl>] and "Armchair GE 290" (b) [<https://www.simplymodern.pl>]

The "Fotel 366/Armchair 366" has a lot in common with foreign furniture from late 1950s and early 1960s, when it comes to style, structure and materials. Definitely, in the period when it was created, Polish artists drew inspiration from Scandinavian design (Fig.8).

Characteristic features of Scandinavian furniture include simplicity, functionality and ergonomics. Moreover, the Scandinavian school of design preferred natural raw materials (wood, leather, stone) and paid attention to the quality of manufacture and detail (Chwierut-Jasicka, Stremlau 1987). Scandinavian design repeated the minimalist functionality of Bauhaus, but contradicted its international character in the sense of a lack of regional features.

The design of "Fotel 366/Armchair 366" also includes some features of the Scandinavian style. There is a striking likeness between the formal solutions of Chierowski's armchair frame and the armchair by Hans J. Wegner presented in Figure 8a. Both have wooden, exposed legs, are highly functional, and their shape is visually light. On the other hand, the minimalism, simplicity and original design of the "Fotel 366/Armchair 366" make reference to the Bauhaus school of design.



Figure 9. Refurbished Polish armchairs from the 1960s: "Lisek" by Hanna Lis (a) [<https://www.manudesign.eu>] and "Stefan" (b) produced mainly for export [<https://www.danielstoiniskiredesign.pl>]

Chierowski was not the only Polish designer fascinated with Scandinavian design. Other designs of Polish post-war furniture have some features in common with this style of design, but comparing to them, "Fotel 366" stands out thanks to its original structural solutions and dynamic form.

The armchairs: "Lisek" designed by Hanna Lis (Fig.9a), "Stefan" produced for export (Fig.9b), or the "Bączyk" armchair by Zenon Bączyk (Fig. 10) are equally iconic for the Polish People's Republic and – similar to "Fotel 366" – they are made of upholstery on a wooden frame. However, comparing to Chierowski's armchair, they are visually very much alike to each other, with conservative forms and little innovation. The "Lisek" armchair has upholstery on a wooden frame and integrated with the back, also supported by horizontal elements connecting two lateral stands, but the stands are made of 4 elements each, and visually it can be seen that the upholstery lies on the frame and is not suspended (Fig.9a). Similarly, the stands support upholstery loosely placed on the visible wooden frame of the seat and the back in the "Stefan" armchair (Fig.9b), or the visually much heavier armchair by Zenon Bączyk (Fig.10).



Figure 10. "Bączyk" armchair designed by Zenon Bączyk [<https://www.pinterest.com>]

3.4. "Fotel 366/Armchair 366" as a design icon – review of renovation and revitalization

Undoubtedly, in the current Polish pop culture, the "Fotel 366/Armchair 366" by Józef Chierowski has achieved the status of an icon of design from the Polish People's Republic. Looking through Internet websites, we can find many sources providing advice on the manners of its restoration (Tab.1). Some of the people do this task well and the final effect is satisfactory. The armchair preserves its antique substance as much as possible, the original shape of the seat integrated with the back is preserved, the structure and finish are refreshed but still faithful to the original, and the conservation task itself is done professionally. Unfortunately, sometimes we can also find examples of incorrect renovation or even revitalization (the aesthetics of the armchair is changed), which significantly affects its value and takes away its status of an antique (Tab.2).

Very often, after the renovation, the armchairs retain the initial features of Chierowski's design (unchanged structure), but the surface finish is different from the original. In most cases, people get rid of the lacquer gloss on the lateral stands (legs and armrests), and opt for a matt finish done, usually by waxing the surface of wooden armchair components. The upholstery, in most cases, is replaced with a new one, and the covering textile is always replaced. Sometimes, the new fabric has uniform colour without any patterns, with a clearly defined texture – similar to the original; but sometimes the armchair is given fabric with a square pattern, which is gaining popularity right now and is considered more visually attractive, which helps it fit into modern interiors. Nonetheless, a question remains whether furniture renovated or revitalised in this way is still an antique armchair?

Table 1. Examples of good conservation works of the "Fotel 366/Armchair 366" found on the Internet

"Fotel 366/Armchair 366" before renovation	"Fotel 366/Armchair 366" after renovation
 <p data-bbox="312 669 659 701">[https://www.rzucpanokiem.pl]</p>	 <p data-bbox="898 669 1228 701">[https://www.rzucpanokiem.pl]</p>
 <p data-bbox="268 1088 694 1120">[https://www.artmamma.blogspot.com]</p>	 <p data-bbox="850 1088 1276 1120">[https://www.artmamma.blogspot.com]</p>

Table 2. Examples of incorrectly done conservation works

"Fotel 366/Armchair 366" before attempted renovation	"Fotel 366/Armchair 366" after attempted renovation
 <p data-bbox="268 1666 700 1697">[https://www.reko-czynny.blogspot.com]</p>	 <p data-bbox="850 1666 1283 1697">[https://www.reko-czynny.blogspot.com]</p>

The "Armchair 366" presented in Table 2. is an example of significant interference with the original design: the fabric does not look like the original fabric and has nothing to do with the style of the 1960s, it is thicker than the original one, so the upholstery looks square in shape, the textile does not cover the upholstery smoothly, and it has been quilted with buttons in a layout completely reverse to the original one; the heads of the screws in the seat have been changed from the rounded ones to flat contemporary ones that have been painted black, while the stands have been covered with dark wood stain in a different colour than the original.

4. CONCLUSIONS

- The "Fotel 366/Armchair 366" designed by Józef Chierowski, thanks to its unique and innovative form, stood out in comparison with other designs from the 1950s and 1960s in Poland and abroad. The armchair has ambitious construction design, which at the same time is simple, and differs from other armchairs from the period of the Polish People's Republic.
- The designer was clearly inspired by Scandinavian design. The exposed wooden legs, high functionality, attention to detail and visually light shape – are all features referring to that style. Its form has also been influenced by the Bauhaus aesthetics: minimalism and functionality.
- The "Fotel 366/Armchair 366" is a perfect design adjusted to the needs of industrial production, using a limited amount of materials with a minimal number of subcomponents that do not occupy much space in storage before assembly.
- Thanks to its small dimensions, the armchair is perfect for small apartments. "Fotel 366" has a very universal shape that can successfully fit in interiors of many different types and sizes.
- The "Fotel 366/Armchair 366" has a simple construction, and the materials used in its production were of high quality (solid wood), thanks to which many pieces have been preserved in good condition – practically without any damage. The disassembly of the armchair's subcomponents is simple and does not require many tools, so many people decide to restore it or revitalise it on their own.
- The armchair's design – already over 60 years old – still remains up to date and attractive, which is confirmed by the reinitiation of production of this classical armchair, and also its high popularity in the second-hand market.

REFERENCES

1. CHWIERUT-JASICKA H., STREMLAU A. 1987. Wzornictwo przemysłu i jego twórcy, Projektanci Skandynawscy. Warszawa. Instytut Wzornictwa Przemysłowego.
2. GRZELUK I. 1998. Słownik terminologiczny mebli. Warszawa . Ministerstwo Kultury i Sztuki.
3. HUML I., 1978: Polska sztuka stosowana XX wieku, Wydawnictwo Artystyczne i Filmowe, Warszawa.
4. KOSTRZYŃSKA- MIŁOSZ A., 2005: Polskie meble 1918 – 1939: forma, funkcja, technika, Wydawnictwo IS PAN, Warszawa.
5. KOZINA I., 2015: Polski Design, Wydawnictwo SBM, Warszawa.
6. Meble do Małych Mieszkań, 1966: Katalog wystawy Warszawa 1966, Wydawnictwo Katalogów i Cenników, Warszawa.
7. ROZANSKA A., SZYMCZYK J., KUJAWA L., BALCERZAK K., BODYCH K., 2021a: Classics of Polish Design. Post-War Polish Furniture Design, Annals of WULS - SGGW Forestry and Wood Technology, 2021, vol. 115, s.85-94.
8. ROZANSKA A., SZYMCZYK J., KUJAWA L., BALCERZAK K., 2021b: Classics of Polish Design. Furniture Icons from the Polish People's Republic (PRL), Annals of WULS - SGGW Forestry and Wood Technology, 2021, vol. 116, s.61-77.
9. SWACZYNA I., 1990: Meble naprawa i odnawianie, Wydawnictwo SGGW, Warszawa.
10. Zjednoczenie Przemysłu Meblarskiego, 1960: Katalog wystawy Poznań 1960, Zjednoczenie Przemysłu Meblarskiego, Poznań.
11. <https://artmamma.blogspot.com/2018/06/renowacja-fotela-366-etap-ii.html>, 10.01.2020r.
12. <https://cotozafotel.pl/fotel-typ-366-jozef-chierowski/>, 20.01.2020r.
13. <https://loftdizajn.pl/jozef-chierowski-zobacz-projekty/>, 20.01.2020

13. <https://manudesign.eu/produkt/fotel-lisek/>, 13.01.2020r.
14. http://reko-czynny.blogspot.com/2016/04/renowacja-fotela-chierowskiego-model_21.html, 10.01.2020r.
15. <https://rzucpanokiem.pl/chierowski-bez-zmian/>, 10.01.2020r.
16. <http://simplymodern.pl/item/fotel-niski-ge-290-proj-hans-wegner/>, 13.01.2020r.
17. http://www.biznesmeblowy.pl/wzornictwo/115/doskonalosc_formy,1004289.html, 15.12.2019
18. <https://www.catawiki.pl/l/23683109-hans-wegner-carl-hansen-son-fotel-krzeslo>, 12.01.2020r.
19. <http://www.danielstoinskiredesign.pl/fotel-tapicerowany-stefan-swarzedzkie-fabryki-mebli/>, 13.01.2020r.
20. <https://www.pinterest.co.kr/pin/485614772317963235/>, 13.01.2020r.
21. <https://vod.tvp.pl/video/rzecz-polska,fotel-366-jozefa-chierowskiego,36441892>, 15.12.2019r. (film)
22. https://pl.wikipedia.org/wiki/J%C3%B3zef_Chierowski, 08.04.2022r.
23. <https://wyborcza.pl/AkcjeSpecjalne/7,155762,23582776,akademia-opowiesci-ta-mila-pani-od-mebli.html?disableRedirects=true>, 20.12.2019r.
24. <https://yestersen.com/pl-pl/p/reedycja-fotela-366-jozefa-chierowskiego> , 15.12.2019r.

Streszczenie: *Klasyka polskiego wzornictwa. "Fotel 366" projektu Józefa Chierowskiego z 1962 roku jako ikona designu PRL-u* przedstawia „klasyka” meblarstwa polskiego okresu „nowoczesności” lat powojennych. Analizie poddana została stylistyka, konstrukcja, a także funkcjonalność tego fotela, oceniona na tle innych znanych zagranicznych i polskich projektów mebli nowoczesnych przeznaczonych do małych mieszkań. Artykuł stara się merytorycznie ocenić źródła ogromnej popularności fotela we współczesnej pop-kulturze, Artykuł kontynuuje cykl „Klasyka polskiego designu”, prezentujący wyniki badań nad powojennym polskim meblarstwem i ikonami polskiego designu, prowadzonych w ramach prac dyplomowych na WTD SGGW.

Corresponding author:

Anna Rozanska
Department of Technology and Entrepreneurship in Wood Industry,
Institute of Wood Sciences and Furniture,
Warsaw University of Life Sciences – SGGW,
Nowoursynowska 159,
02-776 Warsaw, Poland
e-mail: annamaria.rozanska@gmail.com