

Paweł ŚWISŁOWSKI¹, Małgorzata RAJFUR^{1*}
and Tadeusz RODZIEWICZ¹

ASSESSMENT OF EFFECTIVENESS OF THE PHOTOVOLTAIC SYSTEM INSTALLED ON THE ROOF OF THE UNIVERSITY OF OPOLE BUILDING

OCENA EFEKTYWNOŚCI SYSTEMU FOTOWOLTAICZNEGO ZAINSTALOWANEGO NA DACHU BUDYNKU UNIWERSYTETU OPOLSKIEGO

Abstract: The objective of the carried out study was to analyse and assess effectiveness of the photovoltaic system installed on the roof of the University of Opole building at ul. Kominka 6 in Opole. The scope of the study included an assessment of: power generation – the relation between the panels location and energy yield (quantity of generated electric power and geographical location of photovoltaic panels), economic – the period of return on investment and ecological – *ie* how much larger the emission of carbon dioxide by the power plant would be during electric power generation, without work of the photovoltaic system. The studies showed good energy yield of the PV installation, typical return on investment period and ecological aspect of the project, *ie* a considerable reduction of CO₂ emission to atmosphere.

Keywords: renewable energy sources, RES, photovoltaics, photovoltaic panels, effectiveness of PV system, PV cell

Introduction

In consequence of many years of mining and using fossil fuels, a new threat to natural environment appeared. Irrational use of non-renewable sources of energy, such as coal, oil or gas influenced deterioration of natural environment quality by, for example, constant presence of many harmful substances, dust and volatile compounds in atmospheric aerosol, which negatively influence the planet's ozone layer, resulting in irreversible degradation of natural environment. More and more frequent occurrence of

¹ Independent Chair of Biotechnology and Molecular Biology, University of Opole, ul. kard. B. Kominka 6, 45-032 Opole, Poland, phone: +48 77 401 60 42, fax: +48 77 401 60 50.

* Corresponding author: mrjfur@o2.pl

violent storms alternatively with severe droughts is evidence of weather anomalies, which have recently increased their intensity. They are probably caused by the greenhouse effect, which is caused mainly by the emission of toxic products of combustion (CO , CO_2 , NO_x) and other greenhouse gases. A number of fauna and flora species may die out, in consequence of the gradual degradation of natural environment. The observed climate changes are not distant and strange phenomena; also in our country changes can be noticed, in particular in seasons: winters, which have been getting warmer in recent years and hot summers, with extreme high air temperatures. Considerable increase of temperatures in Poland may result in increasing of the Baltic Sea water levels, posing a threat to many coastal seas. Therefore, the dangers caused by anthropogenic activities, may influence not only the world of fauna and flora but also human lives. In view of these dangers, many countries have undertaken steps in order to limit the influence of human civilisation on the climate of our planet. Signing the December protocol in Kyoto in 1997 is one of such activities. On the basis of this agreement related to counteracting global warming, the role of renewable energy sources (RES) increased considerably. Searching for alternatives to fossil fuels became the priority in order to reduce quantities of pollution emitted to the atmosphere. For this purpose, regulations concerning allowed emission limits of pollution from combustion have been introduced and fines for environment pollution have been increased. However, these are the solutions which are applied on the industrial scale and in relation to a whole state policy; there are also methods of individual counteracting the climate changes such as, for example reducing consumption of technical goods or using energy-saving appliances. One of such prospective technologies is the use of solar power converted into electric energy in photovoltaic cells. These technologies have become more and more popular not only because they make it possible to generate electric energy without any side-effects such as pollution, noise or other factors, which would negatively influence natural environment [1–3].

Transformation of solar power into electric energy is possible in photovoltaic cells. This is possible thanks to the photovoltaic phenomenon discovered in 1839 by the French physicist Alexander-Edmond Becquerel [4], also known as “Becquerel’s phenomenon.” The photovoltaic phenomenon (photovoltaic effect, conversion) is based on generation of electrical charge carriers by the material, which absorbed solar beams. A typical photocell made by thick film PV technology is a rectangle semiconductor silicon plate (crystalline, polycrystalline), with the potential barrier formed by, for example, a built-in p-n junction. More information regarding construction of typical PV cells designed for common use can be found in [5–8].

A single PV cell can supply power only to receivers with low current consumption. The power of a standard PV cell, depending on the type and in normal conditions, is within the range of approximately 1–1.5 W at the voltage of 0.5–0.6 V and intensity of about 2 A. A PV cell, as the source of direct electric current, can be easily connected in parallel or series connections, into the systems with higher powers, commonly known as solar panels. Cells are connected in parallel, in order to increase the current. By connecting PV cells in series, a higher voltage is obtained at the exit of the set up. By connecting PV cells in larger systems – modules, solar panels, series, etc., it is possible

to adjust parameters of the generated electric energy to the requirements of the receivers or electric grid. Standard modules available in the market most often contain from 36 to 44 PV cells connected in series. Their typical power is within the range from 12 to 300 W. The professional PV generators use modules with capacity from 250 to 300 Wp. More information on the PV modules construction and PV matrices can be found in [7, 9].

Photovoltaics has been developing very dynamically all over the world and, after water and wind power industries, it is the third technology, as far as the installed power is concerned, which uses RES. The top ten manufacturers of PV cells and modules in the world are: Q-Cells (Germany), Sharp (Japan), Suntech (China), Kyocera (Japan), First Solar (USA), Motech (Taiwan), Sanyo (Japan), SunPower (USA), Yingli Solar (China), Solarworld (Germany/USA) [10, 11].

The condition of photovoltaics in different European Union countries vary considerably, mainly due to different policies and support programs in the sector of renewable energy sources. Germany has been the leader in the European market (EU27) for over 10 years – with more than 80%, installed capacity of 1100 MW and annual energy output of 3.07 TWh [59]. There are two large PV power plants operating in Germany: Strasskirchen (54 MW) and Lieberose (53 MW). The PV power plant near Leipzig built in 2010, with the capacity of 40 MW cost 180 million EUR; it generates 970 kWh of energy every year from 1 kW of the installed power. By the end of 2012, capacity of the PV cells installed in Germany was approximately 32 698.0 MW (in the whole European Union – 68 647.2 MW); 28 TWh energy was generated, which was approximately 2.8% of the total electric energy demand [12, 13].

The production and assembly of PV modules during the years 2011–2012 in the European Union increased from 52 127.3 MW to 68 647.2 MW, from which only 3.4 MW in Poland. Within implementation of the decisions of the climate-energy package of 2008, the EU decided to increase the share of renewable energy in the total energy consumption by 20% (15% for Poland) until 2020, by providing financial aid to member states. Both private and public institutions are allowed to use the financial aid programs for installation of RES and University of Opole is one such example. University of Opole used the resources from the European Regional Development Fund within the Regional Operational Programme for the Opole Province during the years 2007–2013 and implemented Measure 4.3. Air protection, renewable energy sources, titled *Thermal modernization and installation of renewable energy source equipment – the University of Opole didactic building at ul. Kominka 6 in Opole*. The studies on commercial PV cells, focusing on the analysis of influence of various environmental factors on actual efficiency of the cells have been under way for several years at University of Opole, however, the above mentioned investment is of a practical nature and is used to generate renewable source electric energy for the needs of the building [12–14].

Considering that the installation works of the presented PV system were completed and it was commissioned for University of Opole, it became necessary to initiate studies of its efficiency and present the results and remarks regarding its operation.

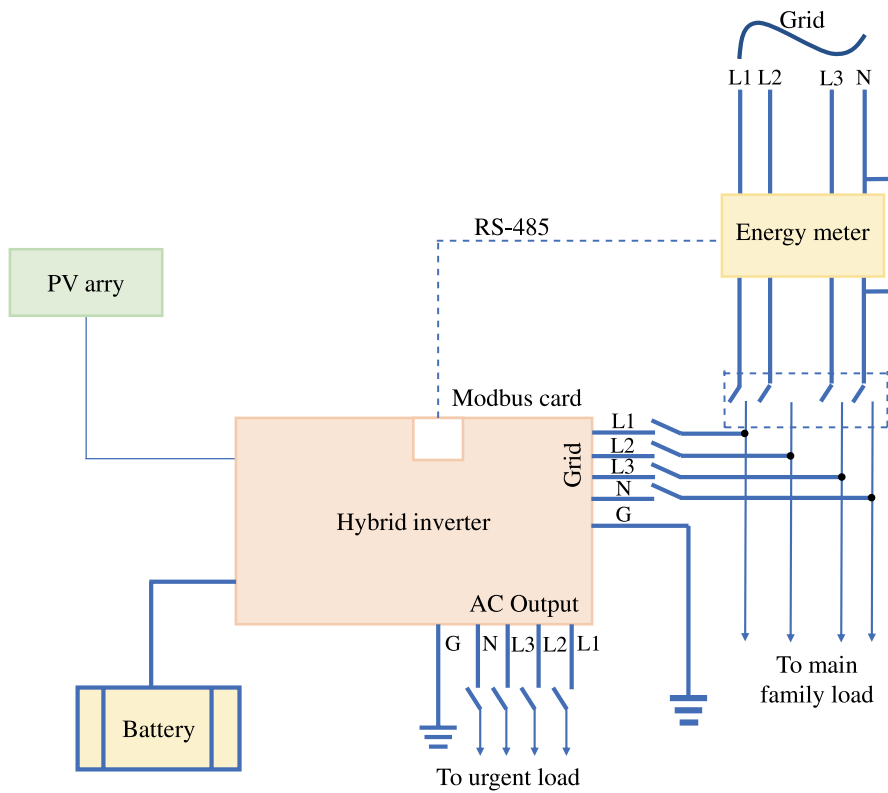

Fig. 1. The photovoltaic system diagram [15]



Fig. 2. A photograph of the PV system installed on the roof of University of Opole building (photo P. Świsłowski)

Materials and methods

The main objective of using the PV system was the reduction of electric energy use by the building users. During the design stage of the PV installation, its location and inclination were optimised, due to the occurrence of the potential shading of the installed PV modules by other buildings. This is an important issue because shading reduces insolation and, in consequence, the installation efficiency. In effect, the PV system was installed on the flat roof of the University of Opole didactic building at ul. B. Kominka 6, at the southern side. This is one of the two buildings owned by Independent Chair of Biotechnology and Molecular Biology (SKBiBM).

Location: Opole – 53,60° N 19,32° E

Level: 115.08 m above the sea level.

Modules inclination for the mounting system: 40°, azimuth 0°.

The PV system with total power of 4.50 kWp contains of 18 hybrid PVT type collectors (*Photovoltaic Thermal*) with 250 Wp power each. The PVT collector is a combination of a solar flat collector and a PV module, containing polycrystalline PV cells. The thermal solar collector converts solar radiation into heat energy, used for hot water production and central heating, whereas the PV module converts solar into electric energy. The used frequency converter with 10 kWp contains two MPP tracker inputs. 2 strings, 4 modules each were connected to the input of the first MPP1 tracker and 2 strings, 5 modules each to the other MPP2 tracker. The estimated exploitation period of the PV system is 25 years. The PV system is maintenance-free and does not require any social facilities and water-sewage installations. Electric energy generated in PV cells will be used for the building's needs – lighting of communication routes with LED light sources (some items are equipped with 360° movement sensors) and power supply to ventilation systems. The PV system will not emit noise or any pollution to environment. Considering the type of investment, there are no local or cross-border influences [15]. As the installed PVT collectors are hybrid (a combination of a solar and photovoltaic panel), this study shall focus only on the electric part, *ie* electric energy generation by the PV system. Fig. 1 presents the diagram of the discussed photovoltaic system. Fig. 2 presents the discussed photovoltaic system.

The high-voltage, photovoltaic, hybrid, three-phase frequency converter InfiniSolar 10 kW with the function of energy storage can supply electric energy to users as well as power own technical equipment (*ie* the



Fig. 3. A photograph of the frequency converter (photo P. Świsłowski)

solar system devices), with the use of: When the PV modules output power is sufficient, it is possible to simultaneously supply power to the user and to charge PV system own batteries and other technical devices [15] (Fig. 3).

Thermal upgrade and mounting the RES equipment for the University of Opole building at ul. Kominka 6 in Opole were completed in May 2015. The data was collected from September 2015 for one year, *ie* until September 2016. The data of the power generated by the PV system was collected on the last day of each month (except for Saturdays and Sundays, when access was impossible). The study activities involved retrieving the registered data with the use of SolarPower 1.07 computer software, which is dedicated to and compatible with the frequency converter of the system. With the use of the program it was possible to read the registered and generated electric energy data from the PV system.

Additionally, on the basis of literature, the energetic [16, 17], economic [18, 19] and ecological [20] analyses were carried out.

The energetic analysis was based not only on the data obtained from the PV system. In order to assess the energetic efficiency of the system, the quantity of the electric energy generated by PV cells was compared with the total quantity of electric energy used by the building. The data regarding energy consumption by the building were obtained thanks to cooperation with the Technical Department of University of Opole.

Thanks to the data obtained from Technical Department regarding costs of use of electric energy in the whole building, it was possible to calculate the economics of the renewable energy source installation program. The time of return on investment, considering the previously assumed PV system exploitation period, was calculated on that basis.

Thanks to the previously prepared results of the energetic analysis of the PV system, it is possible to draw the investment ecological benefits analysis. The objective of that analysis is calculation and assessment of CO₂ reduction, in consequence of electric energy generation by the PV system, instead of a conventional power plant, based on the previously obtained and analysed data.

Results and analysis

Table 1 presents the results of energy yield from the PV system installed on the roof of the University of Opole building.

The electric yield is the quantity of electric energy generated by the PV system during a defined period [21]. Table 2 presents a summary of daily energetic yield plus the sum of kWh electric energy generated during the whole month.

The data for the analysis regarding electric energy consumption in the building of Independent Chair of Biotechnology and Molecular Biology were obtained from University of Opole Technical Department. The data was collected and presented in Fig. 4.

Electric energy is used mainly for lighting didactic lecture rooms, sanitary, social and administration premises. Electric energy is also used to supply power to light sources in laboratories and other equipment, TV and radio equipment, domestic appliances and

Table 1
Energy yield from the photovoltaic installation in [kWh]

Year Month Day	2015						2016						
	IX	X	XI	XII	I	II	III	IV	V	VI	VII	VII	
	[kWh]												
1	26.2	31.5	24.7	2.39	0.23	1.00	0.68	4.02	31.2	36.7	31.7	20.6	
2	14.0	29.6	23.6	0.12	8.21	2.82	17.7	37.3	30.7	20.3	31.7	32.1	
3	29.5	27.2	23.3	1.82	9.18	6.56	0.86	31.7	15.9	15.4	19.5	18.7	
4	14.4	26.4	21.3	10.5	0.49	4.12	3.61	31.6	3.60	30.1	31.4	34.6	
5	24.2	20.2	11.8	13.2	0.75	6.25	14.1	30.7	30.1	28.8	25.6	17.6	
6	8.78	18.4	8.96	14.5	2.95	16.8	5.05	15.0	36.7	35.0	23.5	9.92	
7	20.4	8.52	1.33	0.44	0.36	21.5	1.44	17.8	35.9	37.5	30.1	29.6	
8	23.3	13.1	20.9	0.56	5.78	8.82	3.14	2.20	26.0	36.9	25.5	35.9	
9	23.4	10.9	1.43	1.59	8.05	17.3	3.60	0.79	24.9	19.1	20.4	19.4	
10	18.3	25.5	0.72	8.99	9.68	0.60	5.41	0.61	38.4	21.3	31.7	6.47	
11	14.7	12.8	1.02	8.00	1.31	4.17	0.30	9.78	31.4	18.0	27.0	28.5	
12	31.2	2.45	2.14	12.5	0.43	7.86	0.34	5.92	27.8	32.1	16.6	23.5	
13	29.5	1.39	14.6	1.42	3.66	1.21	2.58	24.5	20.2	13.0	22.4	11.1	
14	21.8	1.10	19.4	8.05	2.69	19.5	27.0	2.23	24.7	19.8	2.93	22.9	
15	19.3	1.41	0.88	0.59	9.39	1.13	2.49	19.1	24.8	24.5	10.2	24.4	
16	21.2	15.0	0.50	3.25	1.05	0.98	32.6	8.55	25.1	31.4	10.9	15.8	
17	31.7	1.08	1.19	0.57	5.00	0.70	32.8	23.7	12.9	25.1	20.1	29.6	

Table 1 contd.

Year Month Day	2015						2016						
	IX	X	XI	XII	I	II	III	IV	V	VI	VII	VII	
	[kWh]												
18	8.55	14.9	1.27	2.45	6.46	0.51	32.0	20.3	17.0	36.1	4.76	25.1	
19	29.7	5.51	1.79	10.8	14.6	0.42	23.4	11.0	23.8	28.9	13.5	22.9	
20	9.48	1.07	1.88	12.9	0.42	16.0	2.33	29.4	22.9	3.41	26.0	27.6	
21	25.0	1.92	1.27	3.26	1.02	2.87	12.8	38.9	35.1	22.6	35.7	3.77	
22	29.3	3.72	5.45	4.54	19.9	12.8	5.79	38.9	35.4	35.0	35.0	18.3	
23	10.7	6.24	6.36	12.5	7.30	1.49	22.2	25.5	36.9	31.0	30.3	25.4	
24	17.8	24.7	17.6	11.2	0.76	17.5	21.9	21.3	28.7	34.6	16.1	27.2	
25	19.8	3.45	10.5	3.57	0.36	1.27	14.0	28.8	24.5	31.6	15.4	36.1	
26	8.48	9.14	0.44	9.30	1.52	7.48	8.18	25.9	8.49	12.0	18.3	36.1	
27	19.4	22.4	4.46	4.03	3.97	20.1	37.2	7.09	28.7	10.8	18.0	34.5	
28	25.7	24.3	13.0	3.84	0.34	5.89	25.7	26.8	22.5	28.3	18.8	34.7	
29	24.4	2.96	1.93	1.33	17.0	0.26	23.7	10.9	8.69	27.3	10.9	24.8	
30	5.97	0.002	2.23	6.24	3.23	—	10.8	n/a	28.2	11.4	n/a	30.2	
31	—	n/a	—	n/a	n/a	—	2.02	—	11.5	—	n/a	4.07	
Total	606	367	246	174	146	208	396	550	773	758	624	731	

n/a – no data available.

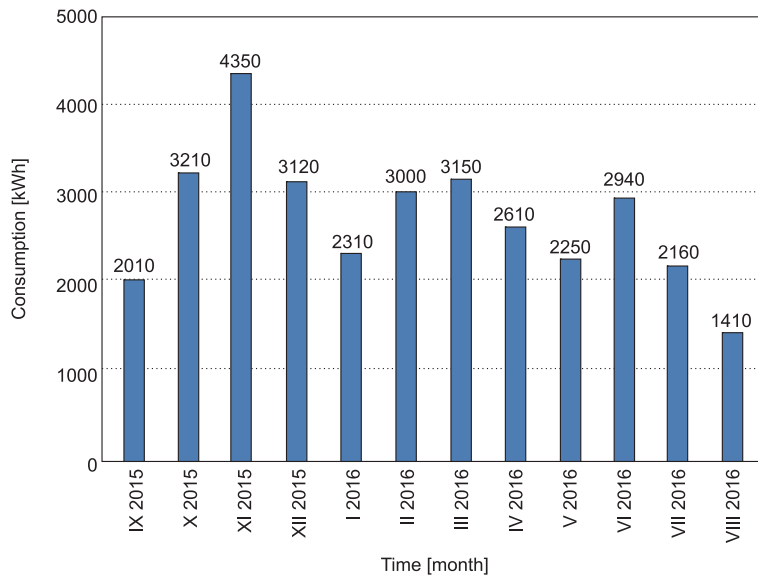

Fig. 4. Mean electric energy consumption in a year

ventilation systems. Electric energy is also used to power machines (grinders, among others) in workshops.

Table 2 presents the percent of covered energy demand with the use of the PV system.

Table 2

Electric energy demand coverage level

Year	Month	Yield [kWh]	Consumption [kWh]	Cover [%]
2015	September	606	2010	30.1
	October	367	3210	11.4
	November	246	4350	5.65
	December	174	3120	5.59
2016	January	146	2310	6.32
	February	208	3000	6.93
	March	396	3150	12.6
	April	550	2610	21.1
	May	773	2250	34.3
	June	758	2940	25.8
	July	624	2160	28.9
	August	731	1410	51.9
	Total	5579	32520	—
	Mean	465	2710	17.2

Table 2 presents percent coverage of electric energy demand by the photovoltaic system. As can be noticed, the new PV system cannot cover total demand for electric energy (it was designed to cover this demand in part).

The following assumptions were made for the calculation of profitability and exploitation of the PV system:

- electric yield of the installation during the first and subsequent years of operation 5.58 [MWh],
- electric energy price (stable) 0.54 [PLN/kWh],
- constant demand for electric energy for 25 years,
- PV installation cost 66 500 [PLN].

The diagram in Fig. 5 presents the time, after which return on investment is obtained.

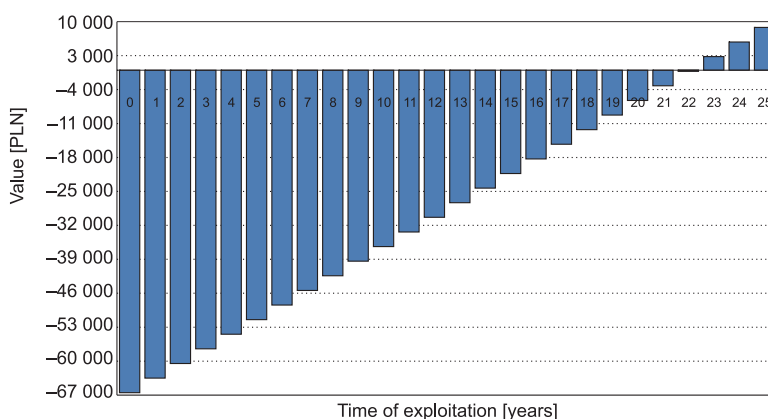

Fig. 5. Diagram of return on investment

Considering the assumptions, return on investment time will be 23 years, as presented in Fig. 5. During the 25 years of exploitation, the photovoltaic installation will generate 16.7 MWh of electric energy (after return on investment period) and the savings should amount to nearly PLN 9 000.

The ecological aspect of the renewable energy source installation is as follows: The emission index for the generated electric energy in combustion sources (from all fuels) is 823,257 kg · CO₂/MWh [20]. On the basis of the data from the National Centre for Emissions Management (KOBiZE) and own calculations, the annual reduction due to electric energy generation from the PV system (5.58 MWh) and not from a conventional power plant is 4.59 Mg of carbon dioxide. In turn, the 25 years of the photovoltaic installation operation shall bring emission to atmosphere reduction of nearly 115 Mg of CO₂.

Summary and conclusions

Renewable energy sources are a real alternative to fossil fuels for the production of electric and heat energy. The degree of their use in Poland has increased [22] despite the

fact that the regulations and energy policy do not give priority to RES. It would be a big challenge to start generating all or part of energy from renewable sources, however, they should be considered in the balanced energy mix. RES development is necessary not just to meet the EU requirements but also considering environmental issues. Ongoing degradation of nature and the increasing pollution with greenhouse gases emitted to the atmosphere cause that RES should be considered as an important element in the struggle against global warming.

The assessment of efficiency of the PV system installed on the roof of a didactic building of University of Opole at ul. Kominka 6 in Opole aimed at analysis of the energetic, economic and ecological effectiveness of the project.

As a result of the carried out study, the following conclusions have been reached:

1. The installed PV system partly covers the demand for electric energy, in line with the Investor's assumptions – University of Opole.
2. Location of hybrid collectors on the southern side, in Opole climate conditions, brought benefits in the form of energy yield of 5.58 MWh/years.
3. The return on investment for purchase and installation of RES is 23 years. From the Investor's point of view, it is a long-term investment; however, during 25 years of exploitation, the PV system generates financial gains.
4. Installing hybrid collectors causes emission reduction of 4.59 tons CO₂/year and 115 tons CO₂ in 25 years. The use of the photovoltaic system improves the image of the institution taking care of natural environment, by using the RES technology in counteracting climate changes.
5. Verification of the obtained data in further analyses of the collected results of energy yield shall allow to determine in more detail the efficiency of the installed PV system.

References

- [1] Waclawek M, Rodziejewicz T. Ogniwa słoneczne. Wpływ środowiska naturalnego na ich pracę [Solar cells. The impact of the environment on their work]. Warszawa: WNT; 2015.
- [2] Gomez-Exposito A, Conejo JA, Canizares C. Electric Energy Systems: Analysis and Operation. Boca Raton: CRC Press 2009.
- [3] Kalogirou SA. Solar Energy Engineering. Processes and Systems. Oxford: Elsevier; 2014.
- [4] Bequerel AE. Mémoire sur les effets électriques produits sous l'influence des rayons solaires. Comptes Rendus des Séances Hebdomadaires, 1839;9:561-567.
- [5] Fahrenbruch AL, Bube RH. Fundamentals of solar cells. Photovoltaic Solar Energy Conversion. New York: Academic Press; 1983.
- [6] Igliński B, Buczkowski R, Cichosz M, Ojczyk G, Plaskacz-Dziuba M, Piechota G. Technologie helioenergetyczne [Helio-energy technologies]. Toruń: Wyd Nauk Uniwersytetu Mikołaja Kopernika; 2013.
- [7] Stryczewska HD. Energie odnawialne. Przegląd technologii i zastosowań [Renewable energies. Overview of technologies and applications]. Lublin: Politechnika Lubelska; 2012.
- [8] Luque A, Hegedus S. Handbook of Photovoltaic Science and Engineering. Chichester: Wiley; 2011.
- [9] Boxwell M. Solar Electricity Handbook. A simple, practical guide to solar energy: how to design and install photovoltaic solar electric systems. Coventry: Greenstream Publishing; 2016.
- [10] OECD/IEA. Renewables for Heating and Cooling. Untapped Potential. RETD Renewable Energy Technology Deployment 2009.
- [11] Klugmann-Radziemska E. Technologiczny postęp w fotowoltaice [Technological advances in photovoltaics]. Czysta Energia. 2014;5:40-42. YADDA: bwmeta1.element.baztech-d273fce6-b144-4a4d-b6b7-189dd92c7ed0.

- [12] Tytko R. Urządzenia i systemy energetyki odnawialnej. Kraków: Towarzystwo Słowaków w Polsce; 2014.
- [13] EurObserv'ER Paris – France 2007–2012 [Monitoring of RES development in the EU]. <https://www.eurobserv-er.org/photovoltaic-barometer-2013/>.
- [14] Regionalny Program Operacyjny Województwa Opolskiego [Regional Operational Program of the Opolskie Province]. <http://rpo2007-2013.opolskie.pl/rpo/index.php?id=7875>.
- [15] Ożóg D, Ożóg K. Projekt budowlano-wykonawczy: „Termomodernizacja i montaż urządzeń odnawialnych źródeł energii” Instalacja ogniw fotowoltaicznych. [Construction-executive design: „Thermal modernization and installation of renewable energy source equipment” Installation of photovoltaic cells.] Pieszyce: Pracownia Projektowania i Nadzorów Elektrycznych; 2015.
- [16] Talavera DL, de la Casa J, Muñoz-Cerón E, Almonacid G. Grid parity and self-consumption with photovoltaic systems under the present regulatory framework in Spain: The case of the University of Jaén Campus. *Renew. Sust. Energy Rev.* 2014;33:752–771. DOI: 10.1016/j.rser.2014.02.023.
- [17] Milosavljević Dragana D, Pavlović Tomislav M, Piršl Danica S. Performance analysis of A grid-connected solar PV plant in Niš, republic of Serbia. *Renew Sust Energy Rev.* 2015;44:423-435. DOI: 10.1016/j.rser.2014.12.031.
- [18] Spertino F, Di Leo P, Cocina V. Economic analysis of investment in the rooftop photovoltaic systems: A long-term research in the two main markets. *Renew Sust Energy Rev.* 2013;28:531-540. DOI: 10.1016/j.rser.2013.08.024.
- [19] Dusonchet L, Telaretti E. Economic analysis of different supporting policies for the production of electrical energy by solar photovoltaics in eastern European Union countries. *Energy Policy.* 2010;38:4011-4020. <http://dx.doi.org/10.1016/j.enpol.2010.03.025>.
- [20] Wskaźniki emisyjności CO₂ dla energii elektrycznej u odbiorców końcowych. [CO₂ benchmarks for electricity end-use]. Kraków: Krajowy Ośrodek Bilansowania i Zarządzania Emisjami KOBiZE; 2014.
- [21] Jurasz J, Krzywdą M, Mikulik J. Wykorzystanie fotowoltaiki w warunkach solarnych miasta Krakowa – wstępne studium wykonalności dla budynku użyteczności publicznej – budynek wydziału uczelni wyższej. [The use of photovoltaics in the solar conditions of the city of Krakow – pre-feasibility study for a public building – the building department of a university]. *Napędy i Sterowanie.* 2013;12:73-77. YADDA: bwmeta1.element.baztech-fe921b71-2317-4f6a-8b2c-c20e32bbfbd2.
- [22] Ingaldi M, Brožová S. Renewable energy sources in Poland. 2013.: <https://depot.ceon.pl/handle/123456789/3353>.

OCENA EFEKTYWNOŚCI SYSTEMU FOTOWOLTAICZNEGO ZAINSTALOWANEGO NA DACHU BUDYNKU UNIWERSYTETU OPOLSKIEGO

Samodzielna Katedra Biotechnologii i Biologii Molekularnej
Uniwersytet Opolski, Opole, Polska

Abstrakt: Celem przeprowadzonych badań była analiza i ocena pracy wydajności systemu fotowoltaicznego zainstalowanego na dachu budynku Uniwersytetu Opolskiego przy ul. Kominka 6 w Opolu. Zakres pracy obejmował ocenę: energetyczną – zależność usytuowania paneli a uzysk energetyczny (ilość wyprodukowanej energii elektrycznej a położenie geograficzne paneli fotowoltaicznych), ekonomiczną – czas zwrotu poniesionych nakładów inwestycyjnych oraz ekologiczną: tj. ile elektrownia wyemitowałaby więcej dwutlenku węgla do atmosfery w wyniku produkcji energii elektrycznej bez udziału tego systemu fotowoltaicznego. Badania wykazały dobry uzysk energetyczny instalacji PV, typowy okres zwrotu poniesionych nakładów na inwestycję oraz na ekologię przedsięwzięcia w postaci znacznej redukcji emisji CO₂ do atmosfery.

Słowa kluczowe: odnawialne źródła energii, OZE, fotowoltaika, panele fotowoltaiczne, efektywność systemu PV, ogniwo PV