

*RICHARD ZEMANN, FRIEDRICH BLEICHER, REINHARD ZISSER-PFEIFER \**

## ELECTROCHEMICAL MICROMACHINING WITH ULTRA SHORT VOLTAGE PULSES

The machining technology of electrochemical micromachining with ultra short voltage pulses ( $\mu$ PECM) is based on the already well-established fundamentals of common electrochemical manufacturing technologies. The enormous advantage of the highest manufacturing precision underlies the fact of the extremely small working gaps achievable through ultra short voltage pulses in nanosecond duration. This describes the main difference with common electrochemical technologies. With the theoretical resolution of 10 nm, this technology enables high precision manufacturing [4].

### 1. Introduction

The tendency to make progressively smaller and increasingly complex products is no longer an exclusive demand of the electronics industry. Many fields such as medicine, biomechanical technology, the automotive, and the aviation industries are searching for tools and methods to realize micro- and nanostructures in various materials. The micro-structuring of very hard materials, like carbides or brittle-hard materials, pose a particularly major challenge for manufacturing technology in the near future. For these reasons, the Institute for Production Engineering and Laser Technology (IFT) of the Vienna University of Technology is working in the field of electrochemical micromachining with ultra short voltage pulses ( $\mu$ PECM) in nanosecond duration. A question, which can illustrate the motivation to do this research work in this field, is: "Which parameters have to be set at a production machine and which framework conditions have to be managed to reach a desired result?" To answer this question for the materials such as nickel and steel (1.4301), the IFT has done experimental work.

---

\* Vienna University of Technology, Institute of Production Engineering and Laser Technology, Landstrasser Hauptstrasse 152, Vienna, Austria; e-mail: zemann@ift.at

## 2. Electrochemical micromachining

Basically, the term machining stands for the removal of material. Furthermore, micromachining is the production of very small scaled shapes and parts in the range of 0.1 – 100  $\mu\text{m}$ . DIN 8580 is the classification of all manufacturing processes. Figure 1 illustrates DIN 8590 for ablation, which is a part of DIN 8580.

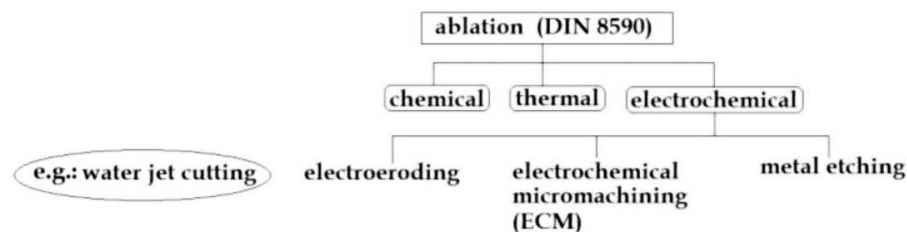

Fig. 1. Classification of ablation (DIN 8590)

Ablation is a non-mechanical separation of material. It can be divided into chemical, thermal and electrochemical methods. For example, water jet cutting is not yet assigned to either ablation methods or to cutting methods. Electrochemical micromachining (ECM) uses electrochemical reactions to treat a metal work piece. These reactions are for example processes in an electrolyser or a battery. In electrolyzers, the chemical reaction is driven by an externally applied voltage, whereas in a battery a voltage is created by a chemical reaction. As depicted in figure 1, the group of electrochemical processes are assigned to ablation, which is a non-cutting technology. Cutting technologies for the realization of microstructures, like high speed cutting, induce mechanical stress, and thermal technologies, like laser ablation, induce thermal stress upon the work piece. Due to the fact that electrochemical technologies have none of these disadvantages, they are of interest to many industrial cases. No stress is induced in the work piece, therefore the structure of the work piece remains unchanged. Another advantage is that there is no machining force necessary, and thus it is possible to machine areas which are difficult to reach. Pulsed electrochemical micromachining (PECM), as well as electrochemical micromachining with ultra short pulses ( $\mu\text{PECM}$ ), belong to the electrochemical micromachining methods. Figure 2 shows the voltage-current curve of metal dissolution. This curve is segmented in active dissolution, passivity and trans-passive dissolution. PECM is positioned in the trans-passive section of the curve (2) whereas  $\mu\text{PECM}$  is positioned in the active metal dissolution area (1). Once a voltage of  $\varepsilon_P$  is reached, the current slopes down rapidly. The current remains low until the end of the passive section. At further increase of the voltage the current rises again to

the trans-passive section. Machines, which are working with technologies in the range of active metal dissolution are more precise, but obtain lower removal rates as the others working in the trans-passive range.

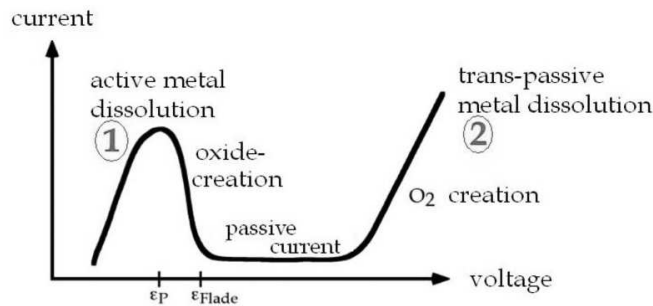

Fig. 2. Schematic illustration of current-voltage curve for metals: The three characteristic sections are: active dissolution, passivity and trans-passive dissolution

Figure 3 shows the main differences between the electrochemical micromachining methods. The conventional ECM uses direct current as energy source. Whereas both PECM and  $\mu$ PECM, use pulsed energy sources, the major difference between these technologies is the pulse width. While the PECM uses pulse widths from milli- to microseconds, the electrochemical micromachining with ultra short pulses uses pulse widths from micro- to picoseconds.

For PECM, the removal rate is dependent on the current density distribution.  $\mu$ PECM directly controls the working gap by locally charging and discharging the so-called electrochemical double layers. This leads to the advantage of  $\mu$ PECM, that the spatial confinement of electrochemical reactions and the thereby produced resolution is very high.

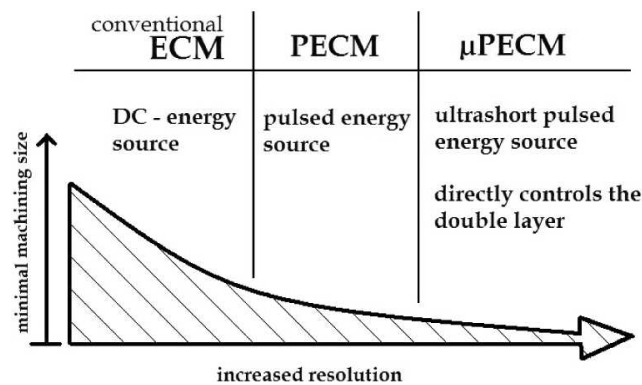

Fig. 3. Comparison of the electrochemical micromachining methods in the field of resolution

### 3. Electrochemical micromachining with ultra short voltage pulses ( $\mu$ PECM)

Electrochemical micromachining with ultra short voltage pulses was developed at the Fritz-Haber-Institute of the Max-Planck-Corporation. Furthermore, this innovative method for micromachining was published for the first time in the beginning of 2000 in Germany. Other universities and companies working on similar topics can be found in Poland, Korea, and Austria. Since late 2010 the Institute for Production Engineering and Laser Technology (IFT) at the Vienna University of Technology has been working with this method as well. The IFT is striving to deliver machining strategies, new material–electrolyte combinations and production parameters for the industrial applicability. The machining technology of  $\mu$ PECM is based on the already well-established fundamentals of common electrochemical manufacturing technologies. The major advantage of the highest manufacturing precision is derived from the extremely small working gaps that are achievable through ultra short voltage pulses. This describes the main difference with common electrochemical technologies. As previously stated, the general advantage of electrochemical machining technologies is that the treatment of the work piece takes place without any mechanical forces or thermal influences. Therefore, no abrasive wear of the tool occurs, and aspect ratios of  $>100$  are possible which sets the basis for extremely sharp-edged geometries. There is no unintentional rounding of edges and no burring on the part.

These days appropriate electrolytes have already been found for several nonferrous metals such as nickel, tungsten, gold etc., as well as alloys like non-corroding steel 1.4301. Nevertheless, a main research focus for the Institute will be the search for new material-electrolyte combinations to expand the field of application for this technology and to enhance its manufacturing productivity. This needs to be accomplished in order to fulfil the requirements of industrial production, because in industries such as the automotive sector the production rate is very important. At the Nano-/Micro-Machining-Center of the IFT, an assortment of high quality measuring devices is available. Based on the technology of  $\mu$ PECM and on the use of high end measuring devices, specimens and parts in the micrometer range are to be manufactured and analyzed in order to investigate material removal rates and the accuracy of resulting work piece geometries.

Due to the multidisciplinary nature of this technology, intensive cooperation with other institutes of the Vienna University of Technology in the fields of electro-technical engineering, high frequency technology and electrochemistry is established. The goal of this research will be to elevate this technology to an appropriate level of possible industrial usage by enhancing

the manufacturing accuracy and the process efficiency for current components. Therefore, a profound knowledge of material science, electrochemistry, and production technology for extremely small dimensions will be required. The necessary expertise in these fields will be provided by the cooperating institutes and interested companies.

To accomplish these improvements in the technology of electrochemical micromachining with ultra short pulses, it will be necessary to merge several research projects which are currently dealing with the topics of piezo-driven nano-positioning devices and the development of high precision machine structures for different types of machines. Table 1 shows all the relevant adjustable parameters for  $\mu$ PECM. In addition to the proper choice of the electrical process parameters like the amplitude of the pulses, the pulse width, the voltages at the tool, and the work piece, the right choice of electrolyte is probably the most important aspect for this process.

Table 1.

Adjustable parameters which have an influence on the process

Adjustable parameters for the process	abbreviations
amplitude of the pulses	A
pulse width	p
voltage at the tool	T
current through the backing electrode	I
pulse-pause ratio	ppr
diameter of the tool	D
electrolyte solution	E

In Fig. 4, the relevant parameters of the applied voltage pulses are illustrated. The duty cycle is the sum of the pulse width and the pause time. A pulse width of 100 ns and a pause time of 800 ns conforms a pulse-pause ratio of 1/8.

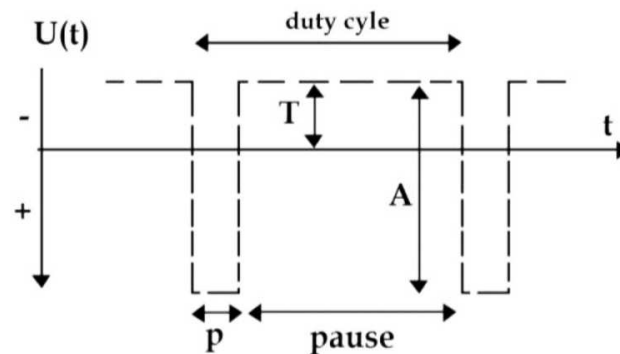

Fig. 4. Pulse-pause ratio of the applied voltage pulse, with pulse width  $p$ , length of pause, amplitude  $A$ , tool voltage  $T$ , applied pulsed voltage signal  $U(t)$

Due to the fact that  $\mu$ PECM is one of the latest elaborated removal technologies, there are no fully developed machines available in the market. All the institutes and companies, which investigate these fields, work with machines in laboratory stage. The machine at the IFT is simple constructed and very easy to maintain, consequently it is adequate for industrial usage. However, a more complex machine structure would give the possibility to reach the highest precision requirement. Figure 5 shows a view inside the IFT's machine. The whole machining process takes place in a basin filled with an electrolyte solution that has to be adequately adapted to the work piece material used. At the bottom of this **electrolyte basin** a hole for the connection of **work piece** and machine can be found. It is important that the basin is well sealed, so that no leakage can occur. The basin is made of Teflon, which has resistance against the electrolytes used in the experiments. Even when filling the basin, caution is required due to the fact that once in contact with the electrolyte, the surface of the material could begin to react. To protect the work piece surface from the influence of the electrolyte-solution, a cathodic protection-current is applied by the **backing electrode** which is immersed in the electrolyte. At the IFT, a tungsten wire is the preferred **tool** for the electrochemical micromachining with ultra short voltage pulses. With the basin filled as needed, the process of work piece calibration can be performed.

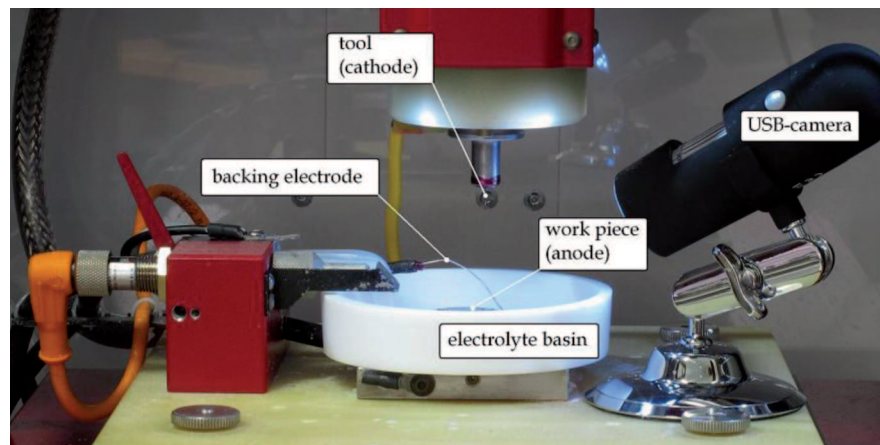

Fig. 5. View inside the electrochemical machine with all important parts for the manufacturing process labelled

The measurement process for finding the work piece surface coordinate is executed automatically by the machine. Therefore, a tool potential is necessary to detect the electrical short circuit through a contact between work piece and tool. Another possible measurement process is to match the local coordinate systems of the work piece with the global coordinate system of

the machine structure. With the result of this measurement process and three positioning screws on the plate, whereon the electrolyte basin is mounted, it is now possible to get the necessary congruence between these two coordinate systems. Then the manufacturing program, which conforms to a standard CNC-program, is started. The tool moves along the pre-programmed paths and selectively ablates material due to the principle, that is based on the finite time constant for double layer charging, which varies linearly with the local separation between the electrodes. During nanosecond pulses, the electrochemical reactions are confined to electrode regions in close proximity [5]. To view the manufacturing process and get optical magnification, a **USB-camera** is used.

Similarly to conventional electrochemical manufacturing methods, the  $\mu$ PECM process uses an oppositional electric voltage for the work piece and the tool. At the phase boundaries between the tool and the electrolyte, and also between the work piece and the electrolyte, an electrochemical double layer is formed [5].

Figure 6 shows the detailed structure of the double layer. The double layer consists of a rigid, outer Helmholtz layer (OHL) and a diffuse area. The inner Helmholtz layer (IHL) is a part of the OHL. In the diffuse area the hydrated metal ions are versatile. The functionality of the OHL can be understood basically as a kind of a plate capacitor, with a plate separation of half of the atom radius [2].

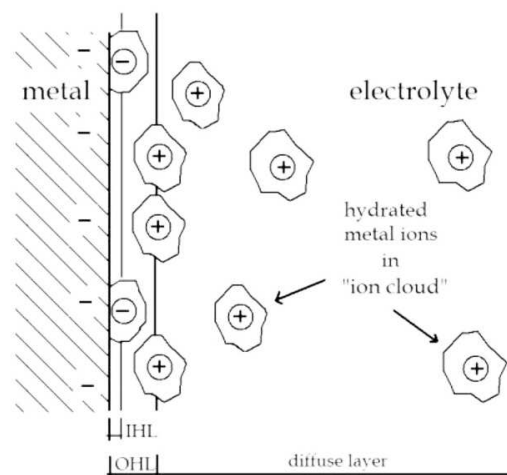

Fig. 6. Simplified Stern-Graham-Model of the electrochemical double layer [2]

The left section of Fig. 7 shows the schematic illustration of the tool, the work piece in the electrolyte basin, and the electrochemical double layers illustrated as plate capacitors. The electrolyte has comparable characteristics

to a linear ohmic resistor with a value that is dependent on the length of the current path. The length of the current path is equal to the distance between the tool and the work piece. The right section of Fig. 7 shows the equivalent circuit diagram in a simplified version of the left illustration in Fig. 7. Through charging and discharging the electrochemical double layer, metal ions are solvated out of the metal surface. If the voltage pulse width is very short, the erosion takes place very closely to the tool ( $R_{short}$ ), since the ohmic resistance of the electrolyte prevents ablation at areas further away from the tool ( $R_{long}$ ) due to the double layer capacitor not being able to be sufficiently recharged [5].

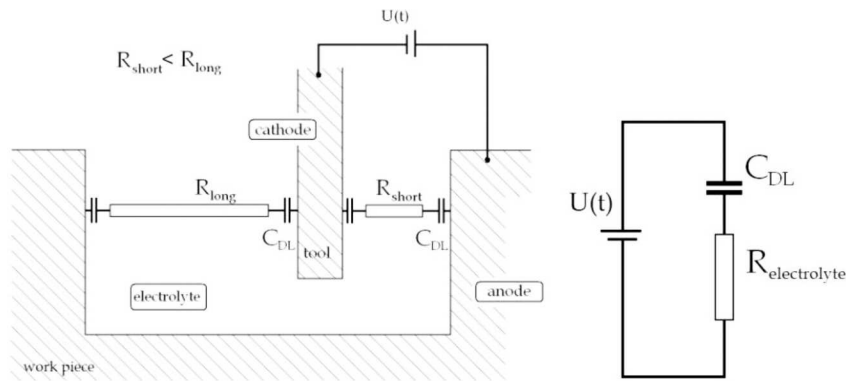

Fig. 7. Schematic illustration of the electrochemical double layers as capacitors and the electrolyte as electrical resistor between tool and work piece (left) and the equivalent circuit diagram (right) with  $U(t)$  as energy source,  $C_{DL}$  as capacitance of the double layers and  $R_{electrolyte}$  as the ohmic resistor of the electrolyte

The right illustration in figure 8 shows schematically the two different charging curves of the double layers at the work piece for  $R_{short}$  and  $R_{long}$ . At smaller distances between the tool and the work piece, the charging curve is steeper; this leads to the formulas (1) and (2).

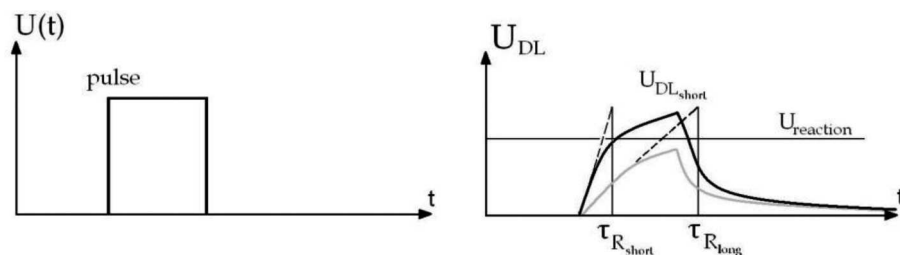

Fig. 8. Applied voltage pulse (left) and time-variable voltage curve in the electrochemical double layer (right)



$$\tau = R_{electrolyte} \cdot C_{DL} \quad (1)$$

$\tau$  . . . time constant for double capacitor charging,  
 $R_{elektrolyte}$  . . . resistance of the electrolyte,  
 $C_{DL}$  . . . capacitance of the electrochemical double layer,

$$U_{DL} = U(t) \cdot (1 - e^{(-t/\tau)}) \quad (2)$$

$U_{DL}$  . . . charging voltage of the electrochemical double layer,  
 $U(t)$  . . . applied voltage with dependence on time,  
 $\tau$  . . . time constant for double capacitor charging.

Another important influence on the charge of the double layers has the pulse width and the choice of the electrolyte. Small working gaps between the tool and the work piece of less than 1  $\mu\text{m}$  are produced with pulse widths of less than 100 nanoseconds and lead to a very high resolution of the machined structure. Even more accurate machining can be achieved with pulse widths of less than 1 nanosecond and by separating the processing pulse into a pre-pulse and a main pulse, which is a future research topic for the IFT. In order to elaborate on the research work concerning the technology of using ultra short voltage pulses, the relevant demands of industry, basically increasing the material removal rate, has to be considered as a main goal. Subsequently, an increase in the already high machining accuracy is regarded as a principal target.

Another major advantage of this technology is the possibility to reverse the process electrically. This means that not only the work piece can be machined, but also the tool itself can be defined as the work piece and be machined to its ideal geometry without any further set-up. Regarding all these functionalities, the requirements for precise micromachining are met. Possible tasks that can be performed with this machining centre include: tooling, milling, turning, sinking, and measuring.

#### **Characteristics of the $\mu\text{PECM}$ process with ultra short voltage pulses:**

- High precision (theoretical resolution of 10 nm),
- No thermal load,
- No mechanical process forces,
- High aspect-ratio >100 (only limited through the Young's modulus of the material),
- No tool wear,
- Small working gaps between tool and work piece (<1  $\mu\text{m}$ ),
- Manufacturing of hard and difficult machineable materials,
- Very small edge-rounding,

- No burring,
- Adjustable roughness of the work piece surface,
- High quality measuring function.

Table 2 shows that electrochemical micromachining with ultra short voltage pulses has several advantages compared to other nano- and micromachining technologies. For example, the theoretical dissolution range and the aspect ratio are outstanding, whereas in the case of the removal rate,  $\mu$ PECM is not competitive against technologies like high speed cutting. For material removal,  $\mu$ PECM is mainly used for post-processing and for producing special surfaces, for example with hydrophobic and hydrophilic characteristics.

Table 2.

Comparison of nano- and micromachining methods [4]

	<b>theoretical dissolution range</b>	<b>aspect ratio</b>	<b>treatable materials</b>	<b>category</b>	<b>removal rate</b>
<b><math>\mu</math>PECM</b>	limit: 10 nm	>100	electrochem. active materials	electrochem. micro-machining	*
<b>Lithography</b>	~10 nm	~1	etch-able, evaporable materials	chemical method	**
<b>LIGA</b>	~100 nm	~100	galvanic removable materials	mechanical/thermal method	**
<b>Laser ablation</b>	~ $\mu$ m	~1	metals and dielectrics	thermal method	**
<b>high speed cutting</b>	~ $\mu$ m	~1	metals and polymers	cutting method	***
<b>FIB</b>	~30 nm	~10	conducting materials	thermal method	**
<b>EDM</b>	~ $\mu$ m	~10	metals	thermal method	**

LIGA... is the acronym for lithography (L), electroforming (E) and molding (A)

FIB...focussed ion beam milling

EDM...electric discharge machining

### 3.1. Tooling

The favoured material used for the tool is tungsten. Tungsten can be easily treated with NaOH as electrolyte and has preferable mechanical properties like a Mohs hardness of 7,5 and a Young's modulus of 410 GPa. For the experimental work wires with a diameter of 75 and 150  $\mu$ m were used. The first tooling step is to cut the tungsten wire manually to a length of 15-20 mm. The wire is fixed with a collet in the toolholder and should protrude far enough to produce the necessary geometries, mostly that is about 4-5 mm.

The toolholder has to be protected from the acid to prevent corrosion, which is performed by a layer of Lacomit. It is a dark red fluid, once hardened it isolates the toolholder against the electrolyte. This red fluid functions as a barrier between the electrolyte and the toolholder. Only the top of the upper part of the tungsten wire is free of Lacomit to treat the work piece. Figure 9 shows two toolholders with the different diameters of tool wire.

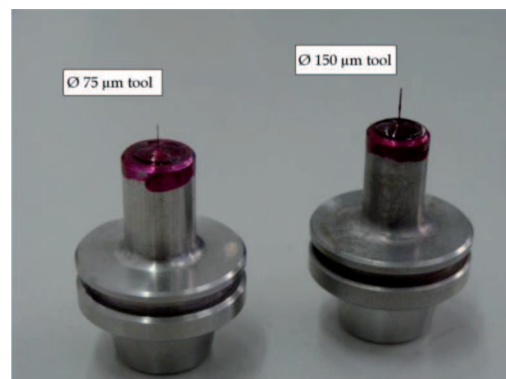

Fig. 9. Tools ready for manufacturing. The left tool has a diameter of 75  $\mu\text{m}$  and the right tool a diameter of 150  $\mu\text{m}$ , both with Lacomit layer

As mentioned before, the tool/wire is cut off manually. Due to the mechanical characteristics of tungsten it is possible that the cut end splits. If that happens, the split section and the usual cut end of the tool (Figure 10, left) has to be removed.

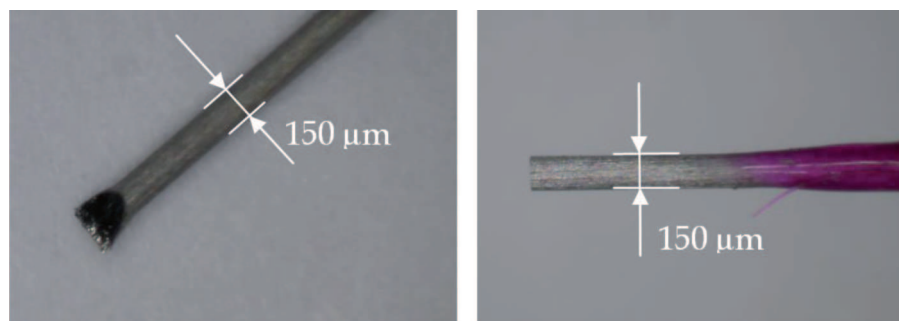

Fig. 10. Tungsten wire with a diameter of 150  $\mu\text{m}$ , untreated with the end after manual cutting (left) and the finished end after electrochemical flattening (right)

The flattening process is performed directly in the  $\mu\text{PECM}$  machine. Due to the fact that the spatial resolution and pulse width are linearly related: the higher the pulse width, the higher the spatial resolution [4], the flattening process is split into two parts to produce a tool with high quality. Another advantage of this sequential machining is that the machining time is reduced.

At first, a large pulse width (i.e. 400 ns) is used to increase the removal speed of the cut end. Afterwards, a smaller pulse width (i.e. 80 ns) is used to create a sharp edged tool with a glossy surface. Only with such tools it is possible to produce geometries with sharp edges on the work piece. Figure 11 illustrates the difference between the radii on the tool's top for small and large pulse widths.

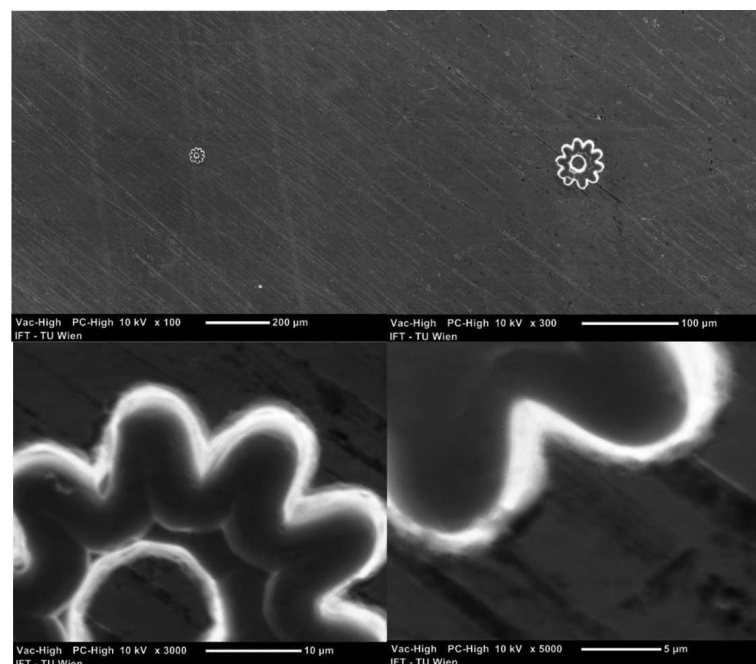

Fig. 11. Images of the microstructure, photographed with a scanning electron microscope (SEM) at different resolutions

### 3.2. Manufacturing of nickel

Nickel is a middle hard (Mohs hardness: 3,8) and ductile metal with a silvery-white and slightly golden shine. Nickel is, apart from chrome and molybdenum, an important element for the refinement of steel. This ferromagnetic metal is corrosion-resistant. Nickel's protective oxide surface resists most acids and alkalis. The corrosion-resistance is one of the most important characteristics of parts in laboratory environments or health care, therefore nickel is the common material in those branches. For the electrochemical manufacturing of nickel, the electrolyte hydrochloric acid (HCl) is used. HCl deactivates the passive surface of nickel and renders the material processable. Different experiments were done to find the optimal processing parameters for the manufacturing of products and special surfaces made of nickel. One

outcome of the investigation was the microstructure in Fig. 11. It has an overall diameter of less than  $50\ \mu\text{m}$ , is  $15\ \mu\text{m}$  deep, and approximately shaped like a gearwheel. This microstructure was manufactured in 4 hours, with an electrolyte concentration of  $0,2\text{M HCl}$ . The tool for this experiment (Fig. 12) was made out of a tungsten wire with diameter  $D = 150\ \mu\text{m}$  by successively reducing the diameter in the tooling basin to  $<5\ \mu\text{m}$ . The magnification of 45 in a light microscope was not sufficient to examine the structure; therefore, a scanning electron microscope has to be used. The experiment shows that the production of a micro injection mould in a range  $<100\ \mu\text{m}$  is possible at the IFT.

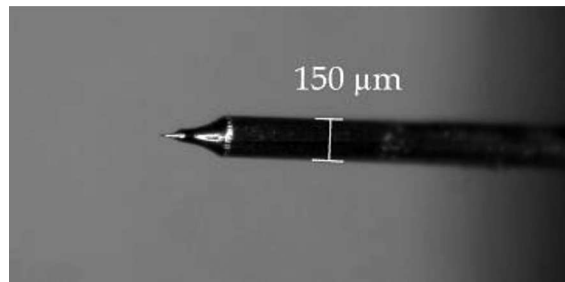

Fig. 12. Image of the tool to produce the micro injection mould with a top of  $D < 5\ \mu\text{m}$

Table 3.

Adjustments for the experiment to produce a micro injection mould

A = 3000 mV	p = 80 ns	T = 100 mV	E = 0,2M HCl
I = 2000 $\mu\text{A}$	ppr = 1/8	D < 5 $\mu\text{m}$	

### 3.3. Manufacturing of steel (1.4301)

1.4301 steel is the most widely used non-corroding steel and it has a very broad scope of application. The need of micro-structuring of such a standard material is continually growing. A solution of hydrofluoric acid and hydrochloric acid was used as electrolyte. The exact designation of this electrolyte solution is  $3\% \text{ HF}/3\text{M HCl}$ . After the basic experiments to define the ranges for the different production parameters at the machine, the goal was to produce the logo of the Institute in a steel plate. The first step was to provide an appropriate tool to produce a high-quality result. The target was to manufacture the logo with a groove width of maximum  $30\ \mu\text{m}$ , so a tool diameter of about  $20\ \mu\text{m}$  was necessary.

Figure 13 shows the result seen through a light microscope with forty-five-fold magnification and table 4 illustrates the used processing parameters.

To get an idea of the dimensions of the logo, a human hair was attached for comparison. The total removal time to produce this logo was 03:04:44 (hh:mm:ss). The groove 0-1 has an adjusted length of 322.5  $\mu\text{m}$  and an adjusted depth of 30  $\mu\text{m}$ . The manufacturing time was 11:02 and the width is 26.3  $\mu\text{m}$ . This leads to a removal rate of 0,027  $10^6 \mu\text{m}^3/\text{min}$ .

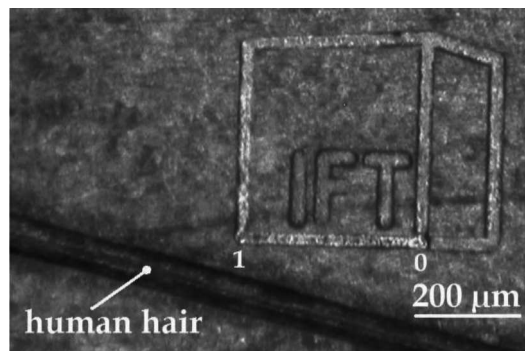

Fig. 13. Logo of the Institute in comparison to a human hair (diameter  $\approx 50 \mu\text{m}$ )

Table 4.

Adjustments for the manufacturing of the Institute's logo

A = 2300 mV	p = 80 ns	T = 100 mV	E = 3% HF/3M HCl
I = 3000 $\mu\text{A}$	ppr = 1/7	D $\approx 20 \mu\text{m}$	

#### 4. Conclusion

The technology of electrochemical micromachining with ultra short voltage pulses has successfully displayed the many applications especially for prototype building or for the manufacturing of special products where there is no other technology which can combine a very high manufacturing precision for special materials without any mechanical forces or thermal influences. [6] In principal, it can be applied to all electrochemically active materials, including semiconductors [5]. Also, the use of applicable effects on process accuracy and material removal rate of difficult to machining materials offers a wide range of possible applications for  $\mu\text{PECM}$  technologies in the future. The occurring electrochemical problems are tradable and topics at the IFT, as well as the micromachining of many different materials like nickel, tungsten, titanium, non-corroding steels, or hard metals. As already mentioned, the machine at the IFT is simply constructed and very easy to maintain, so it is adequate for industrial use. However, a more complex machine structure would enable one to reach highest precision requirements, but needs

more maintenance and a higher financial investment. The experiments on the IFT's machine proved that electrochemical micromachining is achievable for SME's. At this point of research, it is not definitely possible to give tangible instructions on how to reach requested results. This is caused by the complexity of this machining technology; the variation of one of the adjustable parameters could significantly affect the result. It is very much experience necessary to interpret the proceedings at the machine correctly and to enhance the manufacturing process. Due to the multidisciplinary nature of this technology, intensified cooperation with other experts and an extensive research study has to be done, before a reasonable forecast for the processing parameters of a specific manufacturing process can be done.

Manuscript received by Editorial Board, March 03, 2012;  
final version, June 11, 2012.

#### REFERENCES

- [1] Buhler M.: *Elektropolieren*, Eugen G. Leuze Verlag, ISBN 978-3-87480-249-9, Saulgau, Germany, 2009.
- [2] Hamann C.H. & Vielstich W.: *Elektrochemie*, 4. Auflage, WILEY-VCH Verlag GmbH & Co. KGaA, ISBN 3-527-31068-1, Weinheim, Germany, 2005.
- [3] Kirchner V.: *Elektrochemische Mikrostrukturierung mit ultrakurzen Spannungsimpulsen*, Dissertation – Freie Universität Berlin, Berlin, Germany, 2001.
- [4] Kock M.: (2004). *Grenzen der Möglichkeiten der elektrochemischen Mikrostrukturierung mit ultrakurzen Spannungspulsen*, Dissertation – Freie Universität Berlin, Berlin, Germany.
- [5] Schuster R., Kirchner V., Allongue P.: *Electrochemical Micromachining*, SCIENCE Vol 289, sciencemag, 7. July 2000, p. 98-101.
- [6] Zemann R.: *Electrochemical Milling, Annals of DAAAM for 2010 & Proceedings of the 21st International DAAAM Symposium*, ISSN 1726-9679, ISBN 978-3-901509-73-5, s. 843-844.

#### **Mikroobróbka elektrochemiczna z wykorzystaniem ultrakrótkich impulsów napięciowych**

##### Streszczenie

Technologia obróbki, polegająca na mikroobróbce elektrochemicznej z wykorzystaniem ultrakrótkich impulsów napięciowych ( $\mu$ PECM) opiera się na ugruntowanych podstawach powszechnie stosowanych elektrochemicznych technologii produkcyjnych. Ogromna zaleta metody, jaką jest najwyższa precyzja procesu obróbki, wynika ze skrajnie małych odstępów roboczych osiągalnych dzięki użyciu ultrakrótkich impulsów napięciowych o czasie trwania rzędu nanosekund. Ta cecha stanowi o głównej różnicy w stosunku do powszechnie stosowanych technologii elektrochemicznych. Przy teoretycznej rozdzielczości 10 nm, technologia  $\mu$ PECM zapewnia najwyższą precyzję obróbki.