

## Inertial Sensors Applications in Underwater Measurements

Krzysztof BIKONIS <sup>1)</sup>, Jerzy DEMKOWICZ <sup>2)</sup>

Gdansk University of Technology  
Gdansk, Narutowicza str. 11/12, Poland  
<sup>1)</sup> binio@eti.pg.gda.pl, <sup>2)</sup> demjot@eti.pg.gda.pl

*Over the past decades microelectromechanical systems (MEMS) researchers have demonstrated a number of microsensors for almost every possible sensing modality, including attitudes. Current MEMS inertial measurement units (IMU) come in many shapes, sizes, and costs — depending on the application, and performance required. MEMS sensors have proved and demonstrated performance exceeding those of their macroscale counterpart sensors.*

*In the paper chosen IMU applications in underwater measurements are presented. First, for reduction of instability of the underwater sensor during measurements, like multibeam echosounder system (MBES), where the MEMS parameters' quality are crucial for further MBES record-processing. Second, in underwater navigation systems, for determining the position of underwater vehicles, like Remotely Operated Vehicles (ROV) and, more recently, Autonomous Underwater Vehicle (AUV) or to improve other positioning methods.*

**Keywords:** inertial measurements unit (IMU), inertial navigation system (INS), underwater navigation system

### 1. Introduction

MEMS (MicroElectroMechanical Systems) are systems that combine mechanical and electronic components but are made in miniature scale. They have micrometer sizes, but with the advancement of technology, even smaller structures are created, sometimes called NEMS (NanoElectroMechanical Systems). MEMS systems have become quite commonplace, although their development has started relatively recently. Their most known use is in accelerometers, gyroscopes, but there are a number of other sensors that are made using this technology. With time, with the increased precision of their performance, new ideas arise for the use of MEMS.

Almost all MEMS acceleration sensors have a seismic mass and support spring made of silicon. The structure of MEMS gyros is somewhat similar to that of acceleration sensors – a

mass supported by a spring is continuously vibrated in the device, and the Coriolis force generated by the applied angular velocity affects the movement of the mass (vibrating gyroscope). The mass in a MEMS device is very small, and therefore, the inertial forces acting on the mass, especially the Coriolis force, are also extremely small. Thus, the design of the circuit that measures the movement in mass due to the force is important in addition to the design of the mechanical structure. Recently MEMS inertial sensors have been built with an integrated circuit, with sensor structure on a single device chip [1].

A typical structure of a MEMS acceleration sensor is shown in Fig. 1 [1], where a silicon mass is supported by silicon springs and the displacement of the mass due to acceleration is measured by capacitance change between the mass and fixed electrodes. Since the mass is very small and the displacement is also small, the resolution of the device is generally limited to around 0.1 mg Hz<sup>-1/2</sup>.

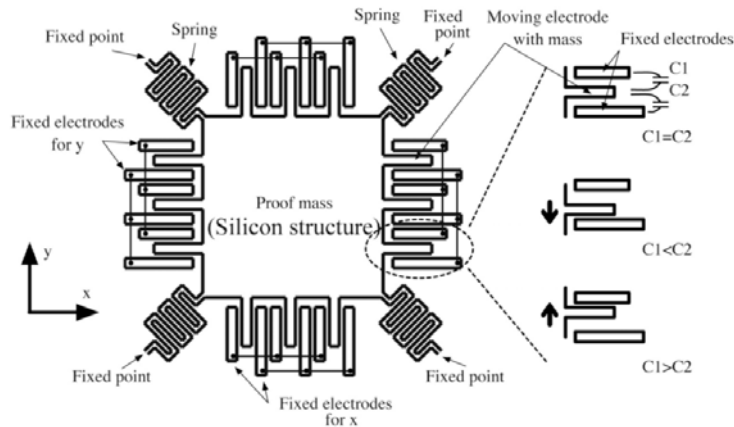

Fig.1. Structure of MEMS acceleration sensor

The basic structure of MEMS gyroscopes is similar to acceleration sensors, i.e., a mass is supported by springs. The main difference in operation is that the angular velocity is obtained by measuring the Coriolis force on the vibrating mass. Thus, the movement of the mass should have at least two degrees of freedom. The device is shown in Fig. 2 [1].

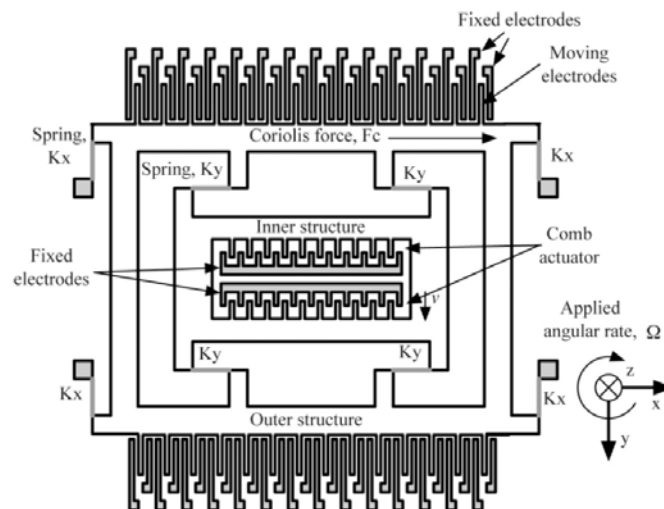

Fig.2. Conceptual structure of an MEMS gyroscope

Inertial sensors have numerous applications. For example, in underwater measurements they are used for reduction of the instability of the underwater sensor in MBES [2], or underwater positioning and navigation systems [3].

## 2. Reduce instability underwater sensor during measurements

Inertial sensors are used to reduce the instability of the underwater sensor during measurements, like MBES system, where the MEMS parameters' quality are crucial for further MBES record-processing. Inertial sensor errors are still a serious issue, where bias error possesses the most important impact. Therefore, usually a Kalman estimator reads in the sensor data, and in turn output, The Kalman filter uses knowledge of the deterministic and statistical properties of the system parameters, and the measurements, to obtain estimates which are optimal [2, 8, 9].

For tests a few IMU units were used, namely Kongsberg MRU from MBSE system, Xsens MTi-G and MTi-G700, Microstrain 3DM-GX3-25 [2]. Results for static tests were presented in Fig. 3, for static Roll measurements. Measurements and results for Roll at different attitudes, and for various IMU units, were performed as well, but are similar and have been omitted in the article.

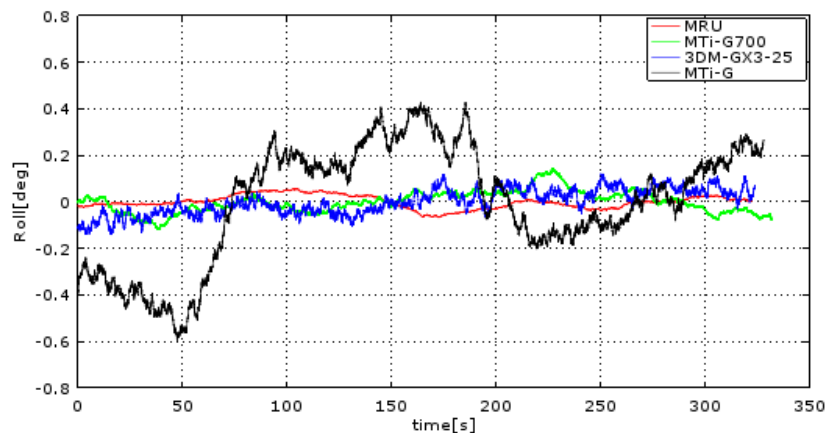

Fig. 3. Measurement results for static tests Roll

Results for dynamic tests give rather opposite results in some situations. In those cases the significant difference can be observed for new generation MTi-G700, 3DM-GX3-25, and for MTi-G, but the MTi satisfies the requirements, see Fig. 4. That is true for frequencies  $<1\text{Hz}$ .

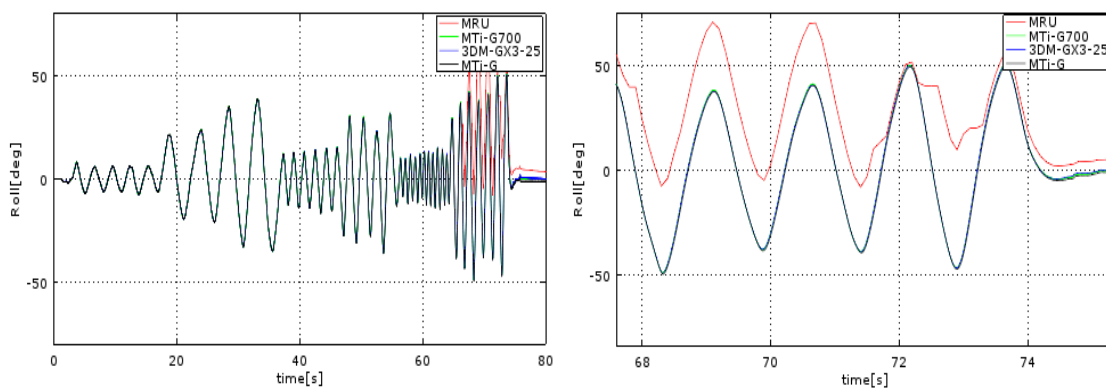

Fig. 4. Dynamic IMU tests for all IMU units

For frequencies close to 1Hz and greater, MRU is very unstable and returns to a stable state after over 16 minutes. The records from MTi-G700, 3DM-GX3-25 and for MTi-G are much better, and the stable state return period lasts over 10 seconds.

### 3. Underwater positioning and navigation systems

The conventional IMU navigation algorithm in inertial navigation system (INS) is to integrate the gyroscopes and accelerometers data (Fig. 5). However, the position values obtained by this method are reliable for only a short period of time. This is due to the accelerometer’s inherent drift error, as well as the gyro rate drift error, which means that when there is double integration of the acceleration measurements, the drift error is also accumulated over time and increases dramatically with time. So the estimated position will be far away from the actual position [3].

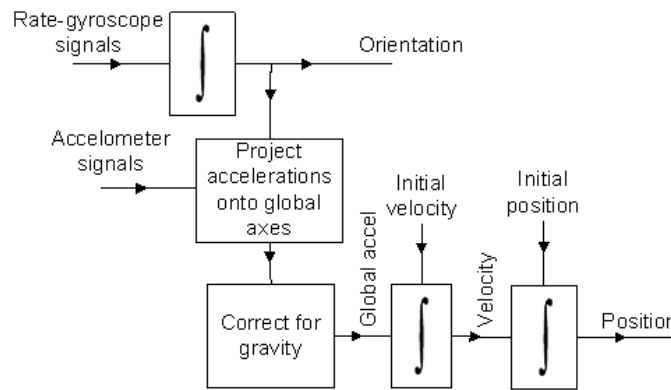

Fig.5. Conventional IMU navigation algorithm

A more efficient approach is the integration of INS and GPS data for navigation [4]. The INS/GPS data integration algorithm is based on Extended Kalman Filter (EKF) usage [5, 6]. The algorithm works in a two-step prediction/correction process. In the prediction step, the Kalman filter produces estimates of the current state variables. Because of the recursive nature of the algorithm, it can be run in real time. The present input measurements and the previously calculated state is used; no additional past information is required [7]. The very idea is presented in the Fig. 6, where  $\hat{x}_{k|k}^-$ ,  $\hat{x}_{k|k}^+$  are á priori and á posteriori system state,  $P_{k|k}^-$ ,  $P_{k|k}^+$  are á priori and á posteriori covariance matrix,  $H_k$  is measurement matrix,  $K_k$  is Kalman gain,  $F_k$ ,  $Q_k$  are process and state variance of the system,  $H_k$  is measurement matrix,  $F_k$  is process model.

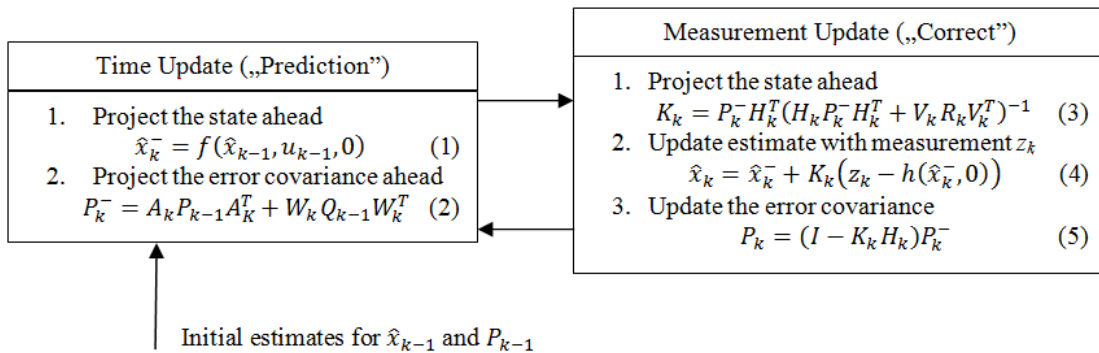

Fig. 6 EKF sensor data integration algorithm diagram [7]

The INS/GPS based localization algorithm is firstly implemented and tested for navigation along a 20m×20m square. The result of the INS/GPS algorithm using EKF is shown in Fig. 7.

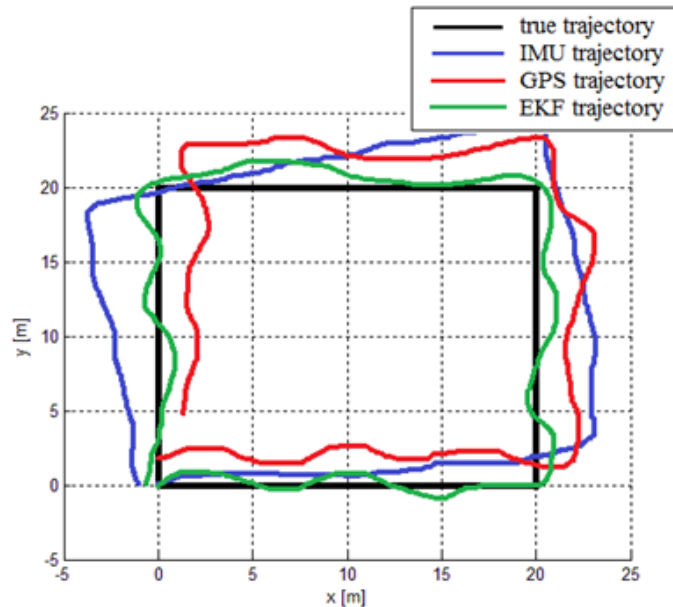

Fig. 7. The navigation results represented by different methodologies for 20mx20m square

#### 4. Summary

Inertial sensors have numerous underwater applications. INS is a self-contained system that integrates three acceleration and three angular velocity components with respect to time and transforms them into the navigation frame to deliver position, velocity, and attitude components. The three orthogonal linear accelerations are continuously measured through three-axis accelerometers while three gyroscopes monitor the three orthogonal angular rates in an inertial frame of reference. In general, IMU, which incorporates three-axis accelerometers and three-axis gyroscopes, can be used as positioning and attitude monitoring devices. However, INS cannot operate appropriately as a stand-alone navigation system. IMU quality is of great importance in overall INS processing chain. The article focuses mainly on the attitudes quality starting from the very precise Kongsberg MRU unit through the low-cost Xsens and Microstrain units. All satisfy the requirements as to attitudes, but in the INS context output and results are still far from acceptable.

#### References

- [1] R. Feliz, E. Zalama, J. G. Garcia-Bermejo, Pedestrian tracking using inertial sensors. *Journal of Physical Agents*, Vol. 3 (No. 1), 2009.
- [2] J. Demkowicz, K. Bikonis, MEMS technology quality requirements as applied to multibeam echosounder, *Hydroacoustics*, Vol. 19, 75-82, 2016.
- [3] K. Bikonis, J. Demkowicz, Data Integration from GPS and Inertial Navigation Systems for Pedestrians in Urban Area, *International Journal on Marine Navigation and Safety of Sea Transportation*, Vol. 7 (No. 3), 401-406, 2013.

- [4] K. Bikonis, J. Demkowicz, A. Stepnowski, Integration of inertial sensors and GPS system data for underwater navigation, *Hydroacoustics* vol. 15, 21-26, 2012.
- [5] Ch. Ling, H. Housheng, IMU/GPS Based Pedestrian Localization. 2012 4th Computer Science and Electronic Engineering Conference (CEEC). University of Essex, 2012.
- [6] S. Leutenegger, R. Y. Siegwart, A Low-Cost and Fail-Safe Inertial Navigation System for Airplanes. 2012 IEEE Conference on Robotics and Automation, 2012.
- [7] J. Kedzierski, Filtr Kalmana - zastosowania w prostych układach sensorycznych, Wrocław, Koło Naukowe Robotyków KoNaR, Politechnika Wroclawska, 2007.
- [8] G. Pengfei, T. Liqiong, M Subhas, MEMS Based IMU for Tilting Measurement: Comparison of Complementary and Kalman Filter Based Data Fusion, 2015 IEEE 10th Conference on Industrial Electronics and Applications (ICIEA), 2015.
- [9] F. Aghili, CH. Y. Su, Robust Relative Navigation by Integration of ICP and Adaptive Kalman Filter Using Laser Scanner and IMU, *IEEE/ASME Transactions on Mechatronics* vol. 21 (No. 4), 2016.