

Robert GREGA<sup>1</sup>, Jozef KRAJŇÁK<sup>2</sup>, Peter BARAN<sup>3</sup>

## THE REDUCTION OF VIBRATIONS IN A CAR – THE PRINCIPLE OF PNEUMATIC DUAL MASS FLYWHEEL

**Summary.** The dual-mass flywheel replaces the classic flywheel in such way that it is divided into two masses (the primary mass and the secondary mass), which are jointed together by means of a flexible interconnection. This kind of the flywheel solution enables to change resonance areas of the engine with regard to the engine dynamic behaviour what leads to a reduction of vibrations consequently. However, there is also a disadvantage of the dual-mass flywheels. The disadvantage is its short-time durability. There was projected a new type of the dual-mass flywheel in the framework of our workplace in order to eliminate disadvantages of the present dual-mass flywheels, i.e. we projected the pneumatic dual-mass flywheel, taking into consideration our experiences obtained during investigation of vibrations.

**Keywords:** combustion engine, vibrations, pneumatic dual-mass flywheel.

## WYELIMINOWANIE WIBRACJI SAMOCHODU – PODSTAWA PNEUMATYCZNEGO DWUMASOWEGO KOŁA ZAMACHOWEGO

**Streszczenie.** Dwumasowe koło zamachowe zastępuje klasyczne koło zamachowe w ten sposób, że jest podzielone na dwie masy (pierwotną i wtórną), które są ze sobą połączone w elastyczny sposób. Z punktu widzenia dynamiki taka konstrukcja koła zamachowego zapewnia zmianę rezonujących stref silnika, czego wynikiem będzie zmniejszenie wibracji. Dużą wadą dwumasowych kół zamachowych jest ich krótka trwałość. Na podstawie uzyskanych w naszej pracowni doświadczeń dotyczących wibracji w celu wyeliminowania wad obecnych kół dwumasowych zaprojektowaliśmy nowy typ dwumasowego koła zamachowego, którym jest pneumatyczne dwumasowe koło zamachowe.

**Słowa kluczowe:** silnik spalinowy, wibracje, pneumatyczne dwumasowe koło zamachowe.

---

<sup>1</sup> Faculty of Mechanical Engineering, Technical University of Košice, Košice, the Slovak Republic, e-mail: robert.grega@tuke.sk

<sup>2</sup> Faculty of Mechanical Engineering, Technical University of Košice, Košice, the Slovak Republic, e-mail: jozef.krajnak@tuke.sk

<sup>3</sup> Faculty of Mechanical Engineering, Technical University of Košice, Košice, the Slovak Republic, e-mail: peter.baran@tuke.sk

## 1. INTRODUCTION

Undoubtedly, reduction of vibrations of the car drive is a very actual topic. It is necessary to pay attention to vibrations from excitation components, that ensure from increasing of emissions in combustion engine. Vibrations like these have not had any impact on the car drive by now.

Mostly, it is result of accidental harmonic components, whose impact becomes more significant due to unstable running of combustion engine and interception of ignition of pistons. Concerning all these facts, as already mentioned above, they have a negative impact on running of the car drive. Resonance becomes evident by changing of vibration amplitudes and by increasing of level of noise as well.

In our dynamical analysis, the car drive, consisting of 3 main parts, specifically a combustion engine, a gear box and a car axle, can be replaced with a three-mass system Fig. 1.

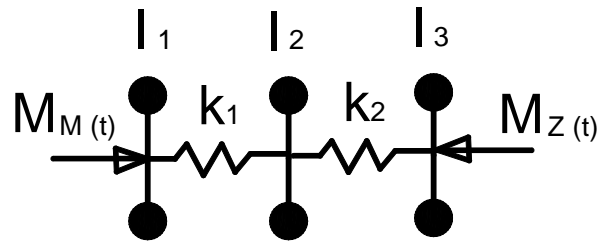

Fig. 1. Schematic model of torsionally oscillating mechanical system without damping  
Rys. 1. Schematyczny model mechanicznego układu drgającego bez tłumienia

where:

$\varphi_1, \varphi_2$ , – angle of twist,

$I_1, I_2, I_3$  – moment of inertia,

$k_1, k_2$  – torsional stiffness,

$M_M(t)$  – loading torque of combustion engine,

$M_Z(t)$  – loading torque of drive wheel.

In this case of solving three-mass system, we obtain two natural frequencies of the car drive formula (1).

$$\Omega_{12}^2 = \frac{k_1 \left( \frac{1}{I_1} + \frac{1}{I_2} \right) + k_2 \left( \frac{1}{I_2} + \frac{1}{I_3} \right)}{2} \pm \sqrt{\left( \frac{k_1 \left( \frac{1}{I_1} + \frac{1}{I_2} \right) + k_2 \left( \frac{1}{I_2} + \frac{1}{I_3} \right)}{2} \right)^2 - k_1 \cdot k_2 \cdot \frac{I_1 + I_2 + I_3}{I_1 \cdot I_2 \cdot I_3}} \quad (1)$$

For even more detailed figure of arisen resonance of mechanical system, it is effectively to use a Campbell diagram Fig. 2. [1]

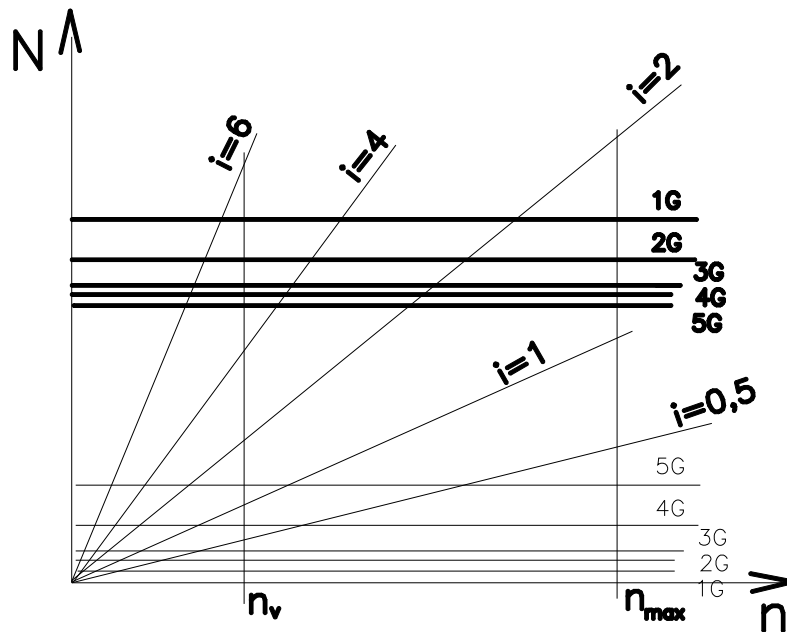

Fig. 2. Campbell diagram  
Rys. 2. Wykres Campbella

Operating range of the mechanical system is shown by revolutions  $n_v$  and  $n_{max}$ . Thin lines marked from  $i=0,5$  to  $i=6$  represent harmonic components of torque. Thin lines marked from 1G to 5G represent speed gear for the first natural frequencies. Thick lines marked from 1G to 5G represent speed gear for the second natural frequencies. It is thus apparent, Fig. 2 shows two resonance areas. Resonance of the first natural frequencies of oscillation occurs under the working area of the combustion engine. A second resonance area of second natural frequencies of oscillation occurs directly at the working area of the combustion engine.

Particularly the second resonance area is more dangerous as the first one because of the frequent increase of level of vibrations and noisiness. Nowadays, it is possible to eliminate these negative impacts by use of the pneumatic dual-mass flywheel in the car drive.

The company LuK produces a new solution of the dual-mass flywheel, Fig. 3. The main purpose of the dual-mass flywheel is a reduction of torsional vibration amplitudes. Such reduction can be reached using separation of the flywheel on two individual masses that are joined each other by means of a flexible connection. Application of the dual-mass flywheels in the diesel engines has also disadvantages with regard to the durability of them. The durability of the flywheel depends on the loading regime predominately. The flexible connection between the both masses is realized with a metal spring, which is stressed due to repeated dynamic impacts during starting-up of coupling, which is connected with one of both masses. The starting phase is characterised by a low speed and high loading. Such kind of fatigue of the connecting spring causes a higher noisiness and higher level of vibrations.



Fig. 3. Dual-mass flywheel LuK  
Rys. 3. Dwumasowe koło zamachowe LuK

Again, the following Campbell diagram shows, Fig. 4 a dynamical impact of the dual-mass flywheel as well as its alternation of resonance area of second natural frequencies. That area, mentioned above, occurs under the working area of the main harmonic component.

The aim of this article is to highlight the accidental harmonic components whose occurrence is caused by unstable ignition of pistons and turning off the pistons, in order to decrease consumption of car.

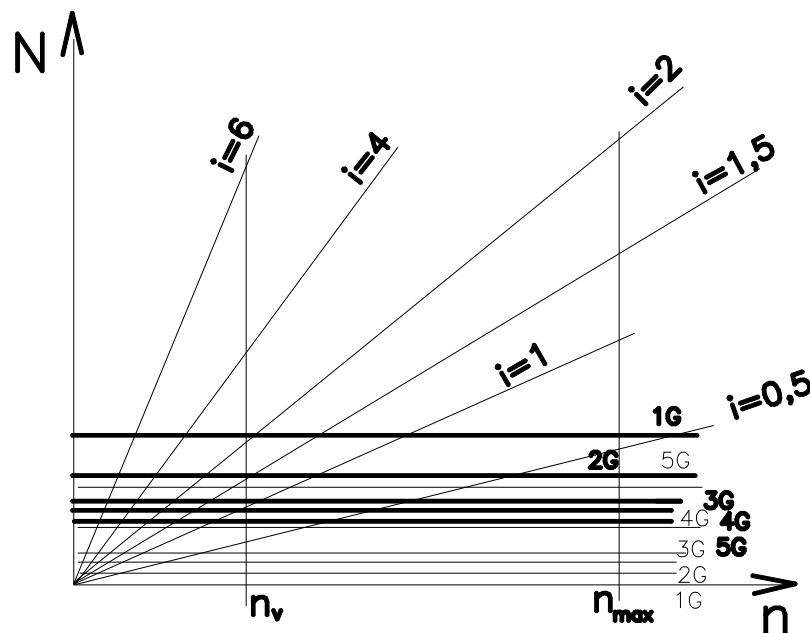

Fig. 4. Campbell diagram with Dual-mass flywheel  
Rys. 4. Wykres Campbella dla dwumasowego koła zamachowego

## 2. THE TUNING OF THE CAR DRIVE WITH PNEUMATIC DUAL-MASS FLYWHEEL

Our research team obtained a great amount of experiences in the development area of machineries and systems projected at our workplaces for reduction of torsional vibrations.

Therefore we developed also a new pneumatic dual-mass flywheel, Fig. 5, which consists of the primary mass (1) and the secondary mass (2). The secondary mass is pressured with the pneumatic flexible chambers that are shaped like half-moons and are filled with the air (3). The primary mass is joined to the carrier (4), which is equipped with the compression pistons (5). The pistons are linked with the pneumatic flexible chambers. The chambers are compressed towards the pistons when they are loaded. The pneumatic dual-mass flywheel is attached to the pneumatic accumulator situated out of the combustion engine. The main task of the pneumatic accumulator is keeping of a constant air pressure in the pneumatic flexible chambers.

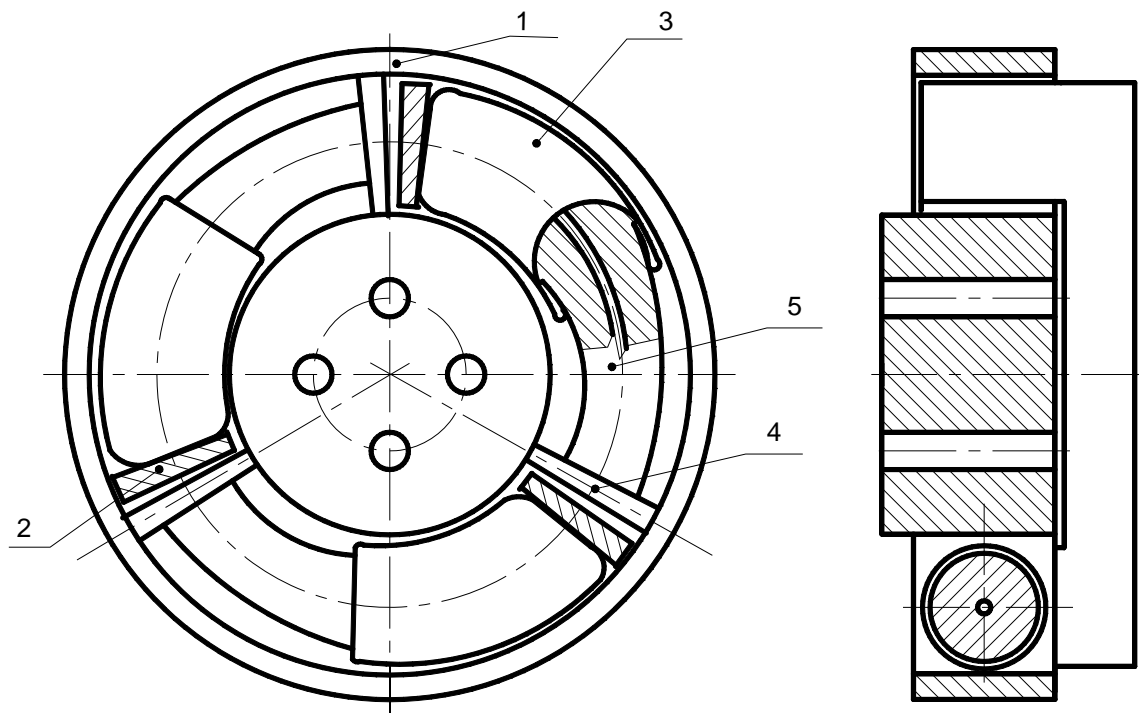

Fig. 5. Pneumatic dual-mass flywheel  
Rys. 5. Pneumatyczne dwumasowe koło zamachowe

There were defined the basic loading characteristics according to the performed theoretical analysis, Fig. 5 and it was specified the static torsional stiffness of the designed pneumatic dual-mass flywheel, Fig. 4. The air pressure in the pneumatic dual-mass flywheel can be changed from the 100 kPa up to 800 kPa. The behaviours signed with the letters from *a* to *h* in the Fig. 6 are the loading characteristics and in the Fig. 7 are presented the courses of static torsional stiffness of the pneumatic dual-mass flywheel operating at the pressure levels from the 100 kPa up to 800 kPa.

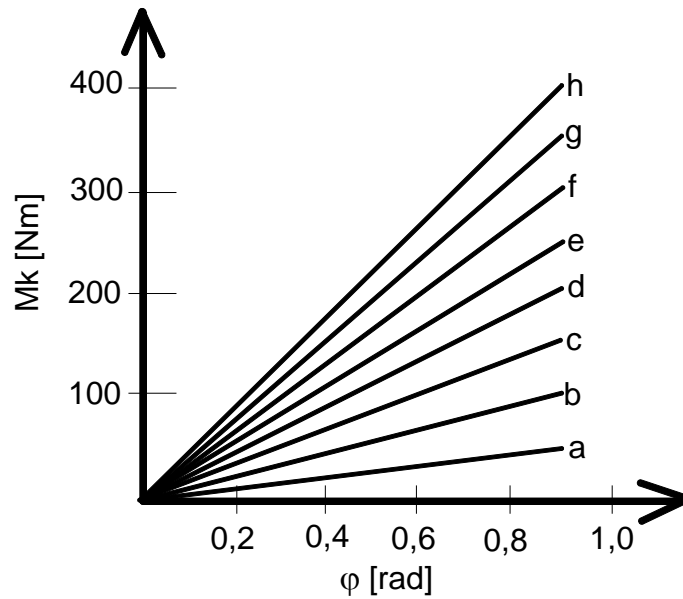

Fig. 6. Loading characteristics of the pneumatic dual-mass flywheel

Rys. 6. Charakterystyki obciążeniowe pneumatycznego dwumasowego koła zamachowego

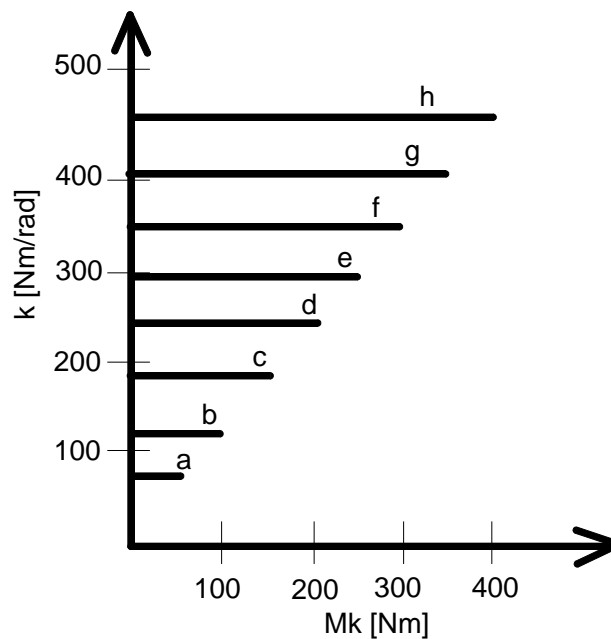

Fig. 7. Characteristics of torsional stiffness of the pneumatic dual-mass flywheel

Rys. 7. Przebiegi statycznej sztywności skrętniej pneumatycznego dwumasowego koła zamachowego

Application of the suggested pneumatic dual-mass flywheel ensures elimination of impacts of accidental harmonic components. Repeatedly, the impact of the mentioned solution for the resonance area of the car drive can be presented by Campbell diagram Fig. 8. Fig. 8 shows a Campbell diagram of a second natural frequencies.

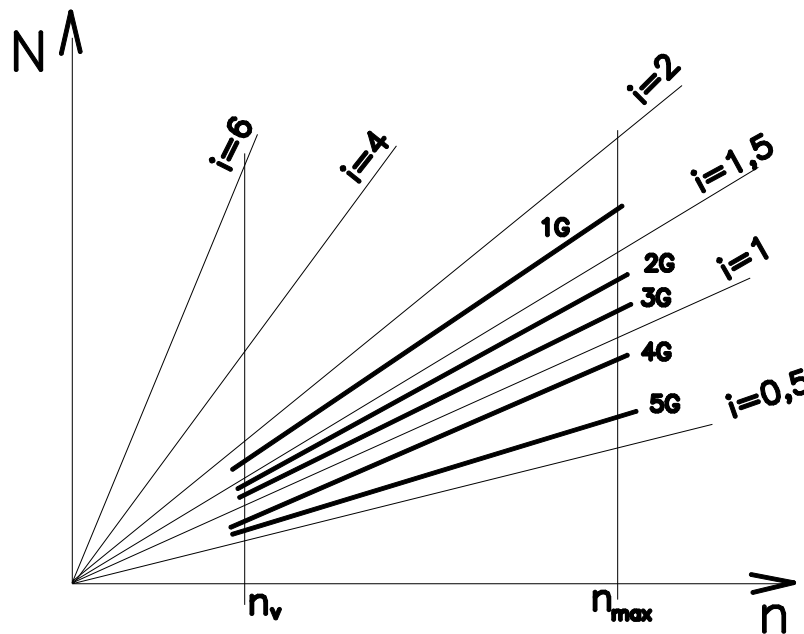

Fig. 8. Campbell diagram with pneumatic dual-mass flywheel

Rys. 8. Wykres Campbella dla pneumatycznego dwumasowego koła zamachowego

### 3. SUMMARY

The pneumatic dual-mass flywheel was projected on the basis of experiences gained at our department in the area of the torsional oscillation tuners.

By changing of the stiffness of the pneumatic dual-mass flywheel it is possible to ensure the change of natural frequency of the car drive during the running of the engine. By this change, we should achieve no resonance area from an accidental harmonic components in working area of the car drive, Fig. 8. This condition could be realized by stepless change of air pressure in the pneumatic dual-mass flywheel, which can change torsional stiffness and thus the change of the own frequency of the car drive.

### Acknowledgment

*This paper was written in the framework of Grant Project VEGA: „1/0688/12 – Research and application of universal regulation system in order to master the source of mechanical systems excitation”.*

### Bibliography

1. Reik W., Torsional vibrations in the drive train of motor vehicles principle considerations, 4-th symposium LUK, 1990.
2. Homišin J.: SúčasnÉ trendy optimalizácie strojov a zariadení. C-Press, Košice 2006.
3. Grega R., Homišin J., Kardoš F.: Porovnanie účelovej funkcie pri bezporuchovom a poruchovom chode mechanickej sústavy. Acta Mechanica Slovaca, roč. 10, č. 4-b, 2006, s. 39-42.
4. Homišin J.: Spôsobý ladenia mechanickej sústavy aplikáciou ladičov torzných kmitov. Acta Mechanica Slovaca, roč. 9, č. 3-b, 2005, s. 5-12.

5. Grega R., Kaššay P.: Porovnanie teoreticko-experimentálnych výsledkov extrémnej účelovej funkcie extrémnej regulácie. 48. Medz. konf. KČSaM 2007, Smolenice, 12 – 14.09.2007, STU, Bratislava 2007, s. 372-377.
6. Grega R.: Prezentácia výsledkov dynamickej torznej tuhosti pneumatickej pružnej spojky s autoreguláciou na základe experimentálnych meraní. *Acta Mechanica Slovaca*, roč. 6, č. 2, 2002, s. 29-34.
7. Grega R., Medvecká S., Kardoš F.: Napätové rozloženie na pneumaticko-pružnom elemente. *Budowa i Eksploatacja Maszyn*, nr 25, 2008, s. 33-38.
8. Homišin J.: Mechanická sústava vhodná pre realizáciu jej plynulého ladenia. Patent č. 276926/92.
9. Homišin J.: Pneumatická pružná hriadel'ová spojka. Patent č. 222411/86.
10. Němeček P.: Diagnostika strojů s vibračním principem činnosti. *Acta Mechanica Slovaca*, roč. 12, č. 3-c, 2008.
11. Sága M., Vaško M., Kopas P., Handrik M.: Príspevok k napätostnej analýze napätosti prúťových a rámových konštrukcií. *Acta Mechanica Slovaca*, roč. 12, č. 3-c, 2008, s. 351-360.
12. Pešík L., Vančura M.: Values identification of kinematic quantities during a mechanical shock. *ACC JOURNAL*, XV, 1/2009, p. 30-35.
13. Haľko J., Vojtko I.: Diferenciálny harmonický prevod a jeho simulácia. *Acta Mechanica Slovaca*, roč. 12, č. 3-c, 2008.
14. Jakubovičová L., Sága M., Vaško M.: 2013, Impact Analysis of Mutual Rotation of Roller Bearing Rings on the Process of Contact Stresses in Rolling Elements. *Manufacturing Technology*, Vol. 13, No. 1, p. 50-54.
15. Sága M., Vaško M.: Stress Sensitivity Analysis of the Beam and Shell Finite Elements. *Communications*, No. 2, 2009, p. 5-12.
16. Žmindák M., Novák P.: Particles Interactions in Composites Reinforced by Fibre and Spherical Inclusions. *Communications*, No. 2, 2009, p. 13-18.
17. Sapietová A., Žmindák M., Sága M., Lack T., Gerlicy J., Dekýš V.: Application of computational and experimental methods in machine mechanics. Pearson, printed and bound great britain by cpi.
18. Vaško M., Sága M., Handrik M.: Comparison Study of the Computational Methods for Eigenvalues IFE Analysis. *Applied and Computational Mechanics*, Vol. 2, No. 1, 2008, p. 157-166.
19. Łazarz B., Wojnar G., Madej H., Czech P.: Influence of meshing performance deviations on crack diagnostics possibility. *Transactions of the Universities of Košice: research reports from the Universities of Košice*, Košice, 3 – 2009, p. 5-8.
20. Sapietova A., Sapieta, M. Hyben, B.: Sensitivity Analysis Application for Multibody System Synthesis. *Applied Mechanics and Materials*, Vol. 420, p. 68-73. Online available since 2013/Sep/27, Trans Tech Publications, Switzerland.
21. Wojnar G.: Model based diagnostics of crack of root tooth for gear in non-stationary operations. *Transactions of the Universities of Košice: research reports from the Universities of Košice*, Košice, 2 – 2011, p. 229-232.
22. Haľko J., Pavlenko S.: Analytical suggestion of stress analysis on fatigue in contact of the cycloidal – vascular gearing system – 2012. *Zeszyty Naukowe Politechniki Śląskiej*, Vol. 76, No. 1864, p. 63-66.
23. Vaško M., Guran A., Jakubovičová L., Kopas P.: 2013, Determination of Contact Stress Depending on the Measure Loading of the Roller Bearing NU220. *Communications*, Vol. 15, No. 2, p. 88-94.