

Nobuyoshi Yamaguchi*, Masato Nakao**

In situ assessment method for timbers based on shear strengths predicted with screw withdrawals

Ocena elementów drewnianych in situ w oparciu o wytrzymałość na ścinanie prognozowaną poprzez badanie na wyrywanie wkręta

Key words: integrity, degradation, inspection, density

Słowa kluczowe: integralność, degradacja, inspekcja, gęstość

1. INTRODUCTION

1.1. Background

Assessment of timbers is required to use existing timber structures for safe and long years. Both of non- and semi-destructive testing methods were used for these assessments of timbers in existing structures. Although non-destructive testing methods are effective in searching of timbers for defects, semi-destructive testing methods such as screw withdrawal resistance measurements have efficiency for evaluating integrity of timbers [1]. Withdrawal resistance measurements had used wood-screws for long years; new probes were developed to measure withdrawals in deep of timbers. The new probes are manufactured from metric threaded rods. The probes are applied not only for 'Single Withdrawal Resistance (SWR)' measurement but also 'Coaxial Multiple Withdrawal Resistance' (CMWR) measurements. The CMWR is able to provide withdrawal resistances distributions on timber cross-sections. Assessment methods to evaluate integrity of timbers using these withdrawals had been proposed [2].

1.2. Objectives

The objective of this paper is to propose the method to evaluate integrity of timbers based on their densities and shear strengths estimated from their withdrawal resistances.

2. METHODOLOGY

2.1. Specimens

Withdrawal resistance measurements and shear loading tests of timbers were conducted. Specimens for withdrawal resistance measurements and shear loading tests were prepared. Species of the timber specimens were Sugi (*Cryptomeria japonica*), Hinoki (*Chamaecyparis obtusa*) and Douglas-Fir (*Pseudotsuga menziesii*). Dimension of the specimens was 30 × 30 × 30 mm. These specimens were cut from a sound and new lumber (cross-section: 105 mm × 105 mm) excluding defects. 16 pairs of Sugi, 9 pairs of Hinoki and Douglas-Fir specimens were used. One-half of specimens were used for withdrawal resistance measurements, the others were used for shear loading tests. A pair of specimens for the withdrawal resistance measurements and the shear loading tests is adjacent along their timber grains. Moisture contents of these Sugi, Hinoki and D-Fir specimens were around 8, 9 and 11% by moisture meters. Densities of them were around 0.38, 0.45 and 0.53 g/cm³ in air condition.

2.2. Probes

Withdrawal resistant measurements uses metric-screw type probes, which are shown in fig. 1. This metric-screw type probe was manufactured from

* Yokohama National University

** Building Research Institute

Cytowanie / Citation: Yamaguchi N., Nakao M. In-situ assessment method for timbers based on shear strengths predicted with screw withdrawals. *Wiadomości Konserwatorskie – Journal of Heritage Conservation* 2015;44:109-115

Otrzymano / Received: 2015-09-08 • **Zaakceptowano / Accepted:** 2015-10-14

doi:10.17425/WK43ASSESSMENT

metric-screws which were commercially available metric threaded rods adjusted to the ISO 261 and 724. The probes have a short-thread which is made up removing the rest of thread from threaded rods by machines. Diameters of the probe threads are constant along the axis. Dimensions of the probe are shown in fig. 1. Length and diameter (peak to peak) of the thread were 12.85 mm and 3.87 mm. Diameter of the remaining shafts was 2.8 mm. Pitch of the threads was 0.7 mm. The probes were screwed downwardly and withdrawn upwardly in the withdrawal measurements. The probes with this dimension are described as 'Standard Probes' in this paper.

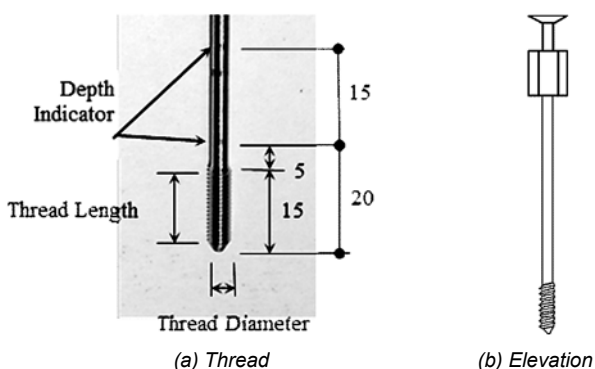

Fig. 1. Standard Probe

2.3. Withdrawal Resistance Measurement

Fig. 2 shows withdrawal resistance measurement. To begin with measurements, a pre-drilled hole of 3 mm (2.94 mm) in diameter is made in the centre of a plane of specimens. The probe is screwed into a pre-drilled hole. Penetration depth of the probe tip in specimens is 20 mm. The depth in the specimens is controlled by the depth indicator marked on the probes. The probe is pulled out slowly and withdrawal resistances are measured simultaneously by the loading apparatus. Constant rate of withdrawals are applied by clamp-type portable loading apparatus driven by electric-drivers.

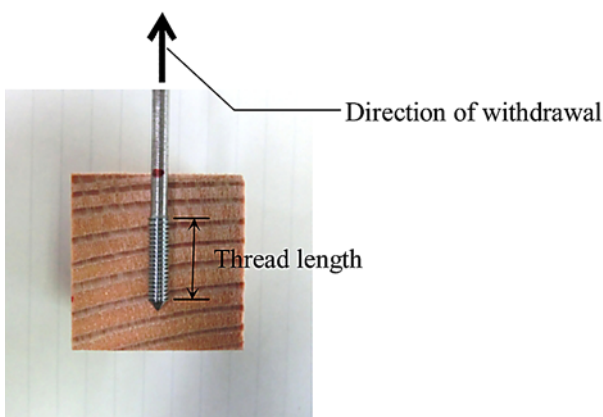

Fig. 2. Withdrawal Resistance Measurements

2.4. Normalized Withdrawal Resistance

Measured withdrawal resistances are affected by areas of outer cylindrical shear planes around the probe threads. Removing effect of dimensions of the probe threads, measured withdrawal resistances W_R were normalized by outer cylindrical area of the thread. These normalized withdrawal resistance (NWR) ${}_N W_R$ is obtained by equation (1) [3]. ${}_N W_R$ indicates estimated shear strength of timber on the outer cylindrical shear plane shown in fig. 3. If the probe is screwed into their longitudinal surfaces (LR and/or LT planes) of the timbers, direction of the measured ${}_N W_R$ (shear strength) will be perpendicular to the grain (RT-direction: Radius or Tangential direction) of the timber.

$${}_N W_R = \frac{W_R}{R_t \times \pi \times l} \quad (1)$$

- ${}_N W_R$ – Normalized Withdrawal Resistance (N/mm²)
- W_R – Withdrawal Resistance (N)
- R_t – Diameter of Threads (peak to peak, mm)
- π – Circular Constant
- l – Length of Probe Thread (mm)

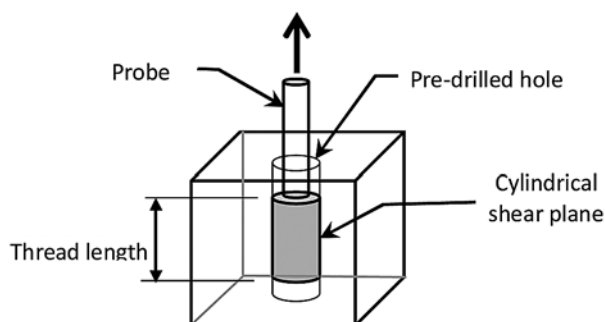

Fig. 3. NWR and Shear Plane around Probe Thread

2.5. Shear Loading Test

In order to obtain regression formula between densities and shear strengths, shear loading test based on JIS Z 2101 was applied for block-shear specimens. Fig. 4 shows the specimens for shear loading test of timbers. Arrows in fig. 4 show directions of applied pair of shear forces. Gap between pair of shear forces was 2 mm. Universal loading apparatus and shear loading jig of INSTRON 2820-060 was used for shear loading tests. Rate of loading was 1 mm/min.

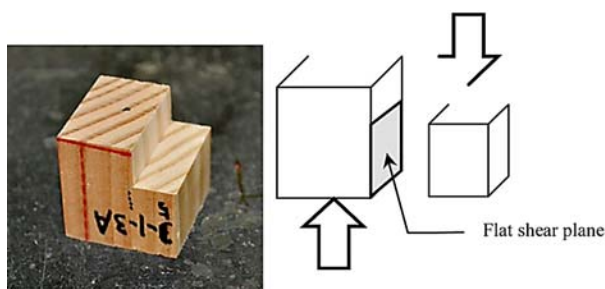

Fig. 4. Shear Loading Test and Specimens

3. RESULTS AND DISCUSSION

3.1. Calculation of Densities from NWR

3.1.1. Relationship between Withdrawal Resistances and Densities

Relationships between measured densities D_m and ${}_N W_R$ of three species of Sugi, Hinoki and D-Fir are shown in fig. 5. A regression formula between D_m and ${}_N W_R$ are shown in Equation (2). In fig. 5, regression coefficients a_1 and a_2 of equation (2) were 0.032 and 0.1745 respectively. Square of coefficients of correlation (R^2) between densities D_m and ${}_N W_R$ was 0.923 in fig. 5. This R^2 value is reasonably good.

$$D_m = a_1 \times {}_N W_R + a_2 \quad (2)$$

D_m – Measured Density (g/cm^3)
 a_1, a_2 – Regression Coefficients

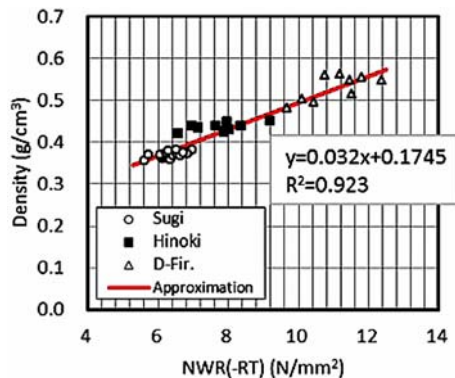

Fig. 5. NWR and Density

3.2.2. Calculation of Densities

Equation (3) provides calculated densities D_c of these specimens in air dry condition, which is based on equation (2).

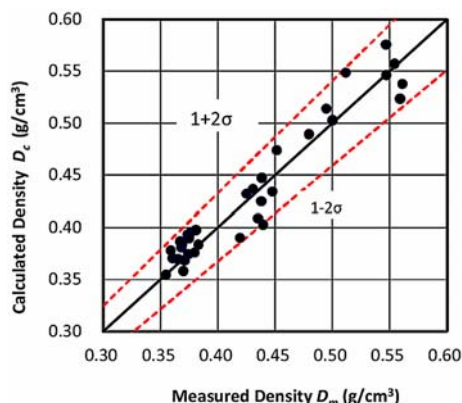

Fig. 6. Verification of Calculated Density D_c

Regression coefficients a_1 and a_2 in equation (3) are also 0.032 and 0.1745 respectively. Measured density D_m and calculated densities D_c of the specimens are plotted in fig. 6, which compares the calculated densities D_c with the measured densities D_m . Standard deviation

σ of the calculated density D_c divided by measured density D_m was 4.0%. Two dotted lines of $1+2\sigma$ times and $1-2\sigma$ times of the measured densities D_m are indicated on the fig. 6. Fig. 6 shows most of the calculated densities D_c is located within these two lines. Equation (3) suggests ${}_N W_R$ would be lost in case timber density is 0.1745. The withdrawals are lost before the density would be zero.

$$D_c = a_1 \times {}_N W_R + a_2 \quad (3)$$

D_c – Calculated Density (g/cm^3)

3.2. Calculation of Shear Strengths from NWR

3.2.1. Relationship between Densities and Shear Strengths

Measured shear strengths of parallel to the grain (L-direction) ${}_M Sh_L$ and measured density D_m of the specimens are plotted in fig. 7. Regression formula of these plots is shown in equation (4). Regression coefficients b_1 and b_2 of equation (4) are 16.024 and -0.4941 in fig. 7 respectively. Square of the correlation coefficients R^2 of this linear approximation formula was 0.8022. This (R^2) value is reasonably good.

$${}_M Sh_L = b_1 \times D_m + b_2 \quad (4)$$

${}_M Sh_L$ – Measured Shear Strength of L-direction (N/mm^2)

b_1, b_2 – Regression Coefficients

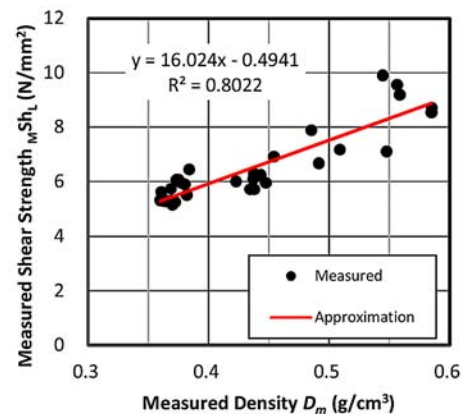

Fig. 7. Measured Density D_m and Measured Shear Strength ${}_M Sh_L$

3.2.2. Calculation of Shear Strengths

Calculated shear strengths ${}_C Sh_L$ are obtained from equation (5), which is derived from equation (3) and equation (4) equating of D_m in equation (4) with D_c in equation (3). Shear strengths ${}_C Sh_L$ are calculated from ${}_N W_R$ using equation (5). Regression coefficients c_1 and c_2 of equation (5) were 0.5128 and 2.3021 respectively. Measured shear strength ${}_M Sh_L$ and calculated shear strength ${}_C Sh_L$ are plotted in fig. 8, which compares the

calculated shear strength cSh_L with the measured shear strength MSh_L . Standard deviation σ of the calculated shear strength cSh_L divided by measured shear strength MSh_L was 8.2%. Two dotted lines of $1+2\sigma$ times and $1-2\sigma$ times of the measured shear strength MSh_L are added on the fig. 8. Fig. 8 shows most of the calculated shear strength cSh_L is located within these two dotted lines. Standard deviation σ of the calculated shear strengths is almost twice of standard deviation σ of the calculated densities.

$$cSh_L = c_1 \times_N W_R + c_2 \quad (5)$$

cSh_L – Calculated Shear Strength of L-direction (N/mm²)

c_1, c_2 – Regression Coefficients

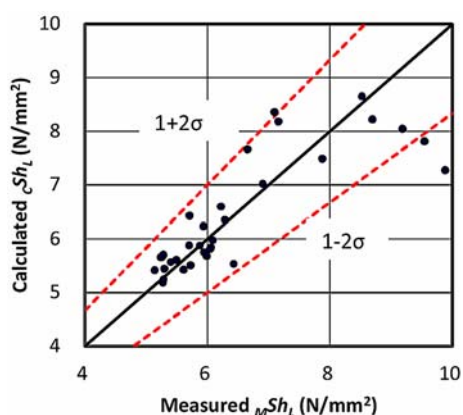

Fig. 8 Verification of Calculated Shear Strength MSh_L

3.3. In-situ Assessment Method using Withdrawal Resistances

3.3.1. Benchmark Method

Benchmark method use benchmark timbers which are reference selected from the same species as object timber. The benchmark timber is required to have average properties of the object timber species. If it is difficult to prepare suitable timbers for benchmark, un-degraded part of the objects is available as the benchmark timbers. The same probes as to the thread diameters and lengths must be applied for the withdrawal measurements of the object timbers and the benchmark timbers. Integrity index I_B is corresponding to the ratio of measured properties of the object timbers to those of the benchmark timbers, which is defined in equation (6). P_r is measured residual properties of the object timbers. P_B is measured properties of the benchmark timbers. The properties are densities or shear strengths. Measured withdrawals would be available instead of densities and shear strengths, because those are calculated from measured withdrawals. Measurement of withdrawals is required for the same grain direction of the benchmark timber as that of object timbers.

$$I_B = \frac{P_r}{P_B} \quad (6)$$

I_B – Integrity index of benchmark method

P_r – Residual properties of object timbers

P_B – Properties of benchmark timbers

3.3.2. Residual Performance Index in Benchmark Method

Mechanical performance of existing timbers is affected not only integrity of timber, timber species but also their cross-sectional areas. Residual performance of the object timbers with their integrity and sectional area losses is evaluated by residual performance index I_{PB} which is given in equation (7). The factor F_S in Equation (7) corresponds to the cross-sectional areas loss and defined in equation (8). A_r is residual/effective cross-sectional areas of the object timbers, and A_o is original/initial cross-sectional areas of them.

$$I_{PB} = I_B \times F_S \quad (7)$$

$$F_S = \frac{A_r}{A_o} \quad (8)$$

I_{PB} – Residual performance index in benchmark method

F_S – Residual cross-sectional areas factor of object timbers

A_r – Residual/effective cross-sectional areas of object timbers

A_o – Original/initial cross-sectional areas of object timbers

3.3.3. Nominal Value Method

Nominal value method is available instead of Benchmark Method. Nominal value method does not need benchmark timbers, but need nominal properties such as densities or mechanical properties of timbers as same timber species as the objects. Those are often listed in major wood handbooks. The nominal properties listed in wood handbooks are average or lower values of clear small timbers [4]. Screw withdrawals are affected by the grain direction of timbers. Withdrawal measurements are applied for perpendicular to the grain direction of timbers in general; these withdrawal resistance measurements provide shear strengths perpendicular to the grain as shown in fig. 3. Because nominal shear strengths listed in wood handbooks are those of parallel to the grain, it is required to estimate shear strengths parallel to the grain from the measured withdrawals perpendicular to the grain. Equation (5) calculates shear strength parallel to the grain from Normalized Withdrawal Resistances $_N W_R$ which is obtained from screw withdrawals perpendicular to the grain of timber.

Direct use of withdrawals W_R is valuable for the assessment works in situ. Withdrawals W_R is calculated

from equation (1) using ${}_N W_R$. There are two cases to assess timbers based on their densities or shear strength parallel to the grain. In case densities are used for assessment, withdrawal criteria W_{RD} correspond to density D are obtained from equation (9), because ${}_N W_R$ is derived from density D by equation (2). Regression coefficients a_1 and a_2 in the equation (2) are also used in equation (9).

$$W_{RD} = \frac{D - a_2}{a_1} \times R_t \times \pi \times l \quad (9)$$

In case shear strengths parallel to the grain are used for assessment of timber, withdrawal criteria W_{RS} correspond to shear strength Sh_L are obtained from equation (10), because ${}_N W_R$ is derived from Shear strength Sh_L by equation (4). Regression coefficients c_1 and c_2 in the equation (4) are also used in equation (10).

$$W_{RS} = \frac{Sh_L - c_2}{c_1} \times R_t \times \pi \times l \quad (10)$$

For the purpose to use these withdrawal criteria W_{RD} and W_{RS} for the assessment of timber *in situ*, these criteria W_{RD} and W_{RS} are plotted in figures. Assuming these equation (3) and (5) are able to be applied for all coniferous species, withdrawal criteria W_{RD} correspond to nominal density D_n of five timber species are plotted in fig. 9 (a). Withdrawal criteria W_{RS} correspond to nominal shear strength $Sh_{L,n}$ of these timber species are also plotted in fig. 9 (b). Sugi and Hinoki are major domestic timbers used for constructions in Japan. Spruce (*Picea*) and Western Hemlock (*Tsuga*) in fig. 9 (a) and fig. 9 (b) are commercially available timbers in Japan imported from North American. These criteria are affected by dimensions of the probes. These withdrawal criteria and measured withdrawals shown in fig. 9 (a) and fig. 9 (b) are effective in case the standard probes are used. Fig. 9 (a) shows the withdrawal criteria ${}_A W_{RD}$, ${}_U W_{RD}$, ${}_L W_{RD}$, correspond to the average, upper and lower values of nominal densities D_n of these timber species. Fig. 9 (b) shows the withdrawal criteria ${}_A W_{RS}$, ${}_L W_{RS}$ correspond to average and lower values of nominal shear strengths $Sh_{L,n}$ of these timber species. Plots of average, upper and lower in fig. 9 (a) correspond to the nominal average, maximum and minimum densities D_n of these timber species. Plots of average and lower in fig. 9 (b) correspond to the nominal average and minimum of shear strengths $Sh_{L,n}$ of these timber species. These nominal values were obtained from the tests using clear timber specimens. Clear small timbers were selected visually excluding defects such as timber knots in these tests [4].

The procedure of the nominal value method:

Select timber species of the object timber on X-axis of fig. 9 (a) or fig. 9 (b). Measure withdrawals W_R of the object timbers using the standard probes shown in fig. 1. Find the position of the measured withdrawals

W_R on Y-axis in these figures. Find intersection points of the timber species on X-axis and the withdrawals W_R on Y-axis in these figures. In case another probe is used, adjusted withdrawals W_R' by equation (11) should be used for the assessment using fig. 9 (a) and fig. 9 (b).

$$W_R' = \frac{{}_s R_t \times {}_s l}{R_t \times l} \times W_{RNS} \quad (11)$$

- W_R' – Adjusted Withdrawal Resistance (N)
- W_{RNS} – Withdrawal Resistance using not standard probes (N)
- ${}_s R_t$ – Diameter of Thread of the standard probe (peak to peak, mm)
- ${}_s l$ – Length of Probe Thread of the standard probe (mm)
- R_t – Diameter of Thread of the probe used in measurements (peak to peak, mm)
- l – Length of Probe Thread of the probe used in measurements (mm)

Assessment by the nominal value method using integrity indexes;

In case the intersections of the timber species on X-axis and measured withdrawals W_R on Y-axis are located upside of the 'Lower or Average withdrawal criteria ${}_L W_{RD}$, ${}_A W_{RD}$ ' in fig. 9 (a), it would be assessed the objects have greater densities than the 'nominal lower or average densities ${}_L D_n$, ${}_A D_n$ ' of the same timber species as them. In case the intersections are located upside of the 'Upper withdrawal criteria ${}_U W_{RD}$ ' in fig. 9 (a), measured withdrawals W_R might be affected by any defects such as hard knots in timber or by other measurement errors. In case the intersections are located upside of the 'Lower or Average withdrawal criteria ${}_L W_{RS}$, ${}_A W_{RS}$ ' in fig. 9 (b), the objects have greater shear strengths than the 'nominal lower or average shear strengths ${}_L Sh_{L,n}$, ${}_A Sh_{L,n}$ ' of the same timber species as them. These figures provides ratio of residual properties of the object timbers to their nominal properties consequently. These ratios are based on densities or shear strengths and are available for quantitative integrity assessment of timbers. Integrity index I_N is ratio of the residual properties P_r of the object timbers to the nominal properties P_N of same species as them, which is defined in equation (12). P_r is residual properties such as densities D_n or shear strengths Sh_L of the object timbers. P_N is nominal properties such as densities D_n or shear strengths $Sh_{L,n}$ of same timber species as the object timbers. Fig. 9 (a) and fig. 9 (b) are able to indicate these integrity indexes visually.

$$I_N = \frac{P_r}{P_N} \quad (12)$$

- I_N – Integrity index of nominal value method
- P_r – Residual properties of object timber
- P_N – Nominal properties of the same timber species as object timbers

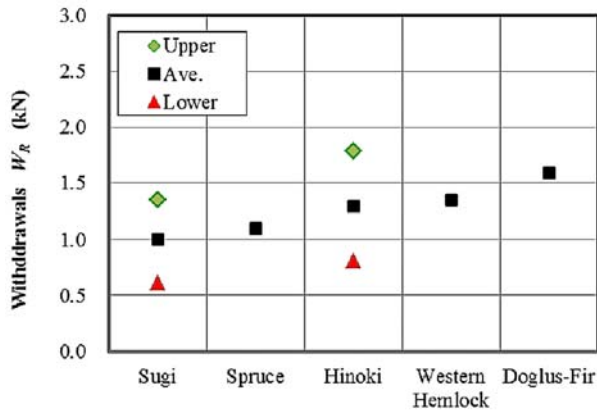

(a) Criteria correspond to Nominal Densities

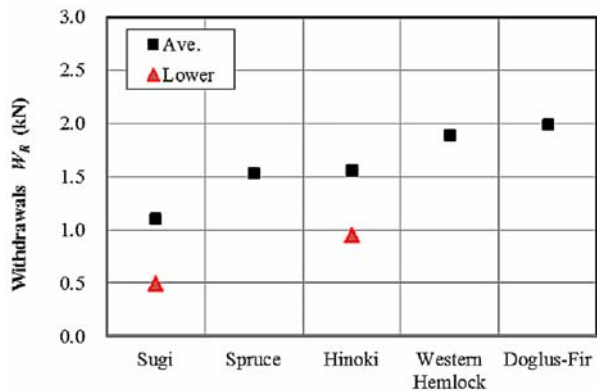

(b) Criteria correspond to Nominal Shear Strengths

Fig. 9. Withdrawals for the Assessment of Timbers by Nominal Value Method

3.3.4. Residual Performance Index in Nominal Value Method

Mechanical performance of timber is affected not only integrity of timber but also their cross-sectional area. Residual performance indexes I_{PN} in Nominal Value Method are given by equation (13). Factor F_s in equation (13) is correspond to the cross-sectional areas loss and defined in equation (8).

$$I_{PN} = I_N \times F_s \quad (13)$$

I_{PN} – Residual performance index in Nominal Value Method.

4. CONCLUSIONS

In situ assessment method of timbers using screw withdrawals was proposed. The probes manufactured from metric threaded rods were developed. Normalized withdrawal resistances ${}_N W_R$ of the probes are proposed, which indicate shear strengths on the shear planes around the outer cylindrical areas of the probe threads. Regression formulae calculating tim-

ber densities and shear strengths from Normalized Withdrawal Resistance were proposed. Standard deviations of calculated densities and shear strengths to the measured them were 4.0% and 8.2% respectively. Two assessment methods of Benchmark Method and Nominal Value Method using withdrawals are proposed. The benchmark method compares withdrawals of object timbers with those of benchmark timbers. The benchmark timbers must be new, sound and average timbers of the same timber species as the objects. The nominal value method use nominal densities and shear strengths (parallel to the grain). Withdrawals correspond to the nominal values of densities and shear strengths were calculated and plotted on figures for the assessments in each species. These figures are used to compare measured withdrawals of the objects with withdrawal criteria correspond to the nominal densities and shear strengths. These figures are available to assess integrity of timbers physically and quantitatively. Ratios of properties of the object timbers to those of benchmark timbers were used as integrity index of benchmark method. Ratios of properties of the object timbers to those of nominal properties were also used as integrity index of nominal value method. Residual performances indexes of the object timbers were proposed, which were obtained from these integrity indexes and cross-sectional area factors.

ACKNOWLEDGEMENTS

I would like to appreciate the members of RILEM TC215-AST and COST Action FP 1101 WG1/TG2, they provide latest information on *in situ* assessment method of timbers for us. I also would like to appreciate Dr. Hirofumi Sakuma of Center for Better Living, Dr. Masahiko Karube and Dr. Hirofumi Nagao of Forest and Forest Products Research Institute Japan for their assistances.

REFERENCES

- [1] Kasal B., Tannert T (eds) (2010) *In Situ Assessment of Structural Timber*. RILEM State of the Art Reports. Volume 7, Springer.
- [2] Tannert T., Anthony R.W., Kasal B, Kloiber M., Piazza M., Riggio M., Rinn F., Widmann R., Yamaguchi N. (2014) *In situ assessment of structural timber using semi-destructive techniques*, Materials and Structures 47(5): 767-785.
- [3] Yamaguchi N. (2013) *In situ Assessment Method of Wood using Normalized Withdrawal Resistances of Metric-screw type Probes*, Advanced Materials Research 778: 217-224.
- [4] Forest and Forest Product Research Institute (2004) *Wood Industry Handbook*, ISBN 4-621-07411-3 C 3550, Maruzen, Japan.

Abstract

In situ assessment method of timbers using screw withdrawals is proposed. The screw withdrawals are obtained from withdrawal resistance measurements of timbers using probes manufactured from metric threaded rod. Two assessment methods of 'Benchmark Method' and 'Nominal Value Method' are proposed. The benchmark method compares both of withdrawals of object timbers and 'benchmark timbers' in order to evaluate the integrity of the objects. The benchmark timbers are new and sound timbers of the same species as the objects. The nominal value method use nominal densities or shear strengths of the same timber species as the objects. Withdrawal resistance measurements and shear loading tests of three coniferous species of timbers were conducted in order to determine two regression formulae between their withdrawals and densities, densities and shear strengths. Two set of linear regression coefficients for estimating densities and shear strengths from withdrawals were obtained. Withdrawal criteria correspond to the nominal densities and shear strengths are calculated using these two regression formulae. The withdrawals measured from the objects are compared to the withdrawal criteria correspond to the nominal values of the same species as the objects. *In situ* assessment method of timbers using quantitative integrity indexes obtained by the benchmark method and nominal value method are proposed. Residual performances indexes of the object timbers are proposed, which are obtained from these integrity indexes and cross-sectional area factors.

Streszczenie

Artykuł prezentuje metodę ewaluacji *in situ* drewna w konstrukcjach. Badania na wyrywanie wkręta prowadzone są za pomocą sondy wykonanej z pręta z metrycznym gwintem i mierzą opór drewna przy wyrywaniu wkręta. Przedstawiono dwie metody oceny: 'metodę porównawczą' i 'metodę wartości nominalnej'. Metoda porównawcza porównuje opór przy wyrywaniu wkręta z testowanych elementów drewnianych do wartości oporu generowanych dla 'elementów referencyjnych', aby określić integralność elementu. Elementy referencyjne to elementy z nowego i zdrowego drewna tego samego gatunku, co drewno badanego elementu. Metoda wartości nominalnej wykorzystuje nominalne wartości gęstości lub wytrzymałości na ścinanie dla gatunku drewna takiego, z jakiego wykonany jest badany element. Przeprowadzono pomiary za pomocą badania na wyrywanie wkręta i testy wytrzymałości na ścinanie drewna pochodzącego z trzech gatunków iglastych, aby ustalić dwa wzory współczynnika regresji pomiędzy oporem przy wyrywaniu wkręta i gęstością, oraz gęstością i wytrzymałością na ścinanie. Na podstawie badań otrzymano dwa zestawy liniowych współczynników regresji dla oszacowania gęstości i wytrzymałości na ścinanie. Wartości oporu przy wyrywaniu wkręta odpowiadają nominalnym wartościom gęstości, a wytrzymałość na ścinanie oblicza się na podstawie dwóch wzorów na regresję. Wartości oporu przy wyrywaniu wkręta zmierzone dla elementów są porównywane z wartościami nominalnymi dla takich gatunków drewna, jak użyte w danej konstrukcji. Artykuł przedstawia metodę oceny *in situ* z wykorzystaniem ilościowych indeksów integralności drewna otrzymanych za pomocą metody porównawczej oraz metody opartej na wartościach nominalnych. Zaproponowano też indeksy pracy szczątkowej dla badanego drewna w konstrukcjach, które zostały określone na podstawie indeksów integralności i czynników przekrojowych.