

ANALYSIS OF THE POSSIBILITIES OF USING MODERN PROCESS WORKING MARINE DIESEL ENGINE

Dominika Cuper-Przybylska

*Gdynia Maritime University, Faculty of Marine Engineering
Morska Street 81-87, 81-225 Gdynia, Poland
tel.: +48 58-5586-439
e-mail: d.cuperprzybylska@wm.am.gdynia.pl*

Abstract

Increasing public awareness of environmental protection, it has caused a lot of emphasis on the marine industry to create reciprocating diesel environmentally friendly. Conducting research on real objects in the laboratory gives us the solution to the problem. However, such studies generate large financial resources, especially for marine engines also take a lot of time. Creating a simulation on a computer allows for the limited financial resources and also speeding up work on the piston marine engine. Computer simulations allow the creation of more complex physical models, which can describe the process of operating a marine diesel engine. However, the complication models cause a problem of the future understanding of the model and the possibility of subsequent use of it, for example for control of the engine.

The more it established the need to simplify complex models of engines for better understand the processes occurring in the engine. The article is a description of the Mean Value Engine Model (MVEM), which were analysed individual blocks of the model together with the modifications related to the environment in which the engine will run. Modular model allows better modifying it and adding new blocks. This model is based mainly designed for application control. Because of the simple structure easy to adjust for different types of engines. This is particularly good for use in motor drivers. It allows better matching engine operating parameters to reduce emissions of harmful substances into the environment and also achieve better efficiency of marine engine.

Keywords: *diesel, engine, model, MVEM, marine engine, Mean Value Engine Model*

1. Introduction

When in 1892. Rudolf Diesel developed the engine ignition, no one has thought about creating appropriate models representing the processes occurring in the engine. There was no need for advanced engine drivers, did not realize the impact of exhaust gases on the environment. However, today, the shortage of power produced and the increasingly stringent natural protection laws make that energy efficiency and environmental protection are becoming increasingly important aspect for the maritime industry.

There was therefore a need to create models of marine diesel engines which is not only maintain the good dynamic properties and but also to improve fuel economy and minimize emissions of toxic exhaust fumes. One of the important objectives of the motor model is the ability to predict the characteristics of the engine in harsh environments, which will operate a diesel engine or rapid load changes. Due to time ascent and descent of the screw because of the waves of the sea, or changes in load to the motor forced through manoeuvres. The models are simulator engine; it can change the dynamic parameters, as well as a failure simulation.

To simulate the working process engine uses differential equations. Simulation models of diesel engines may generally be classified as quasi-static models, models and features volume.

One of the popular models of engines is the Mean Value Engine Model (MVEM). Presented for the first time by E. Hendricks in 1989, is joining quasi-static model with a volume model. The diesel engine is divided into several relatively independent blocks, such as receiver scattering air, diesel engine exhaust, turbo, intercooler.

Volume model was used only in stationary simulations; it was not used for dynamic processes of change in the engine. In 1991, he was enriched model of the crankshaft, which sets out the basis for the volumetric model used for dynamic simulation. The pattern divides the process into a working volume for the compression, combustion, expansion and exhaust, wherein the process acts as a dynamic simulation.

2. Mean value engine model (MVEM)

The average value of the motor model (MVEM) provides adequate accurate description of the dynamics of the engine with a reasonable approximation, ignoring the heat loss. Today, modern engines are becoming more complicated, when equipped with a turbocharger model MVEM simplifies the process of creating a model for the type of engine.

MVEM engine is divided into several blocks relatively independent of each other. Fig. 1 shows a schematic diagram of a compression ignition engine.

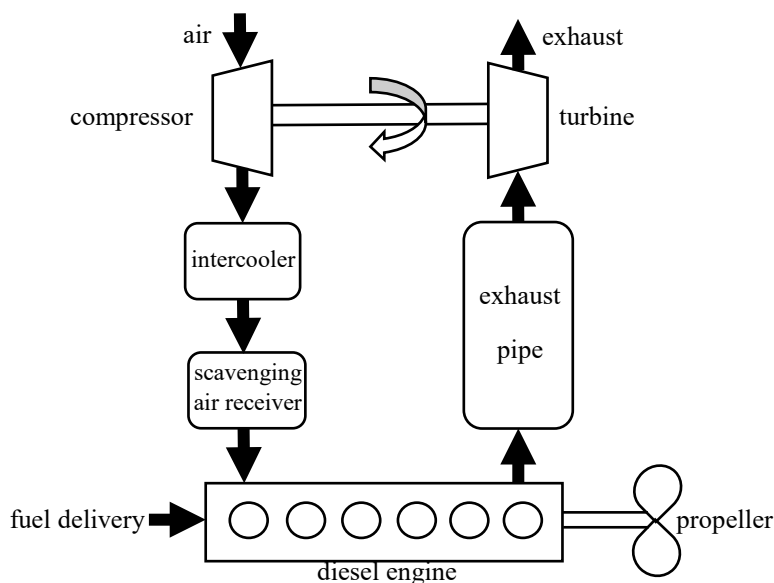

Fig. 1. Scheme marine diesel engine

The turbine drives the compressor, which compresses fresh air. The air is cooled in the cooler and passed to the air distributor. Which is fed into the engine cylinder. Meanwhile Lead is the fuel that is burned in the cylinder to allow the movement of the piston. The piston produces a torque transmitted to the receiver power. In marine units, the most common screw. Exhaust gases are removed from the cylinders, exhaust gas temperature drops in the pipes, exhaust gases drive the turbine.

Figure 2 shows a block diagram of an exemplary modern MVEM ignition engine. The blocks represent modules that from which the model is created ignition engine. Through modular design facilitates data entry and subsequent modernization of the individual block. As the suitable fasteners (e.g. in making the engine model of the EGR system).

3. Blocks MVEMs

The air supplied

Excess air ratio is an important parameter of combustion and emission means a ratio of blow air to the magnitude of the actual combustion air. At the appropriate coefficient of excess air can improve its thermal efficiency, lower exhaust gas temperature and reducing pollution. Therefore, excess air ratio has a tremendous impact on accurate modelling.

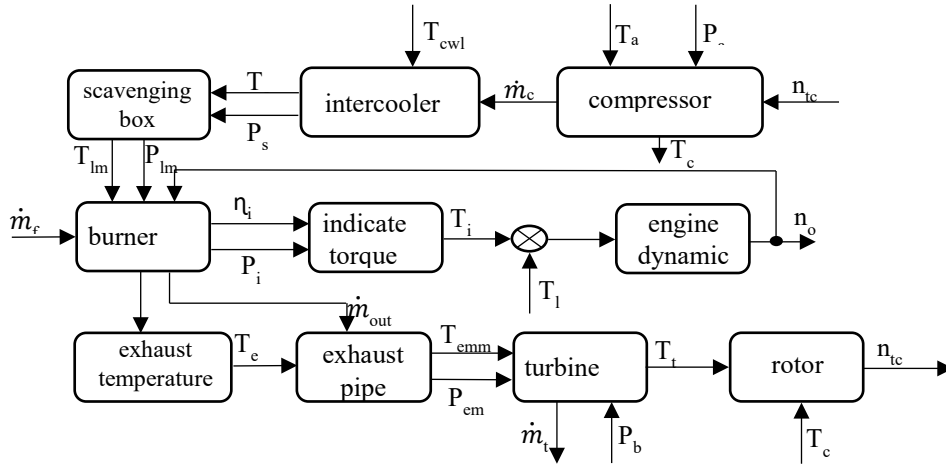

Fig. 2. Block diagram of a diesel engine for MVEM

The modelling MVEM used simple models of one-dimensional (1D) where the effects are omitted boards, appearing in the flow pipe and are analysed in the multivariate models.

The mass flow of air into the cylinder can be calculated as follows:

$$\dot{m}_{in} = \eta_w \frac{p_{im} V_d N_{cyl} n_e}{60 N_{st} R T_{im}}, \quad (1)$$

where:

p_{im} – suction pipe pressure,

η_w – cylinder volume coefficient,

N_{cyl} – cylinder number,

V_d – empty volume in each cycle,

n_e – engine revolution,

N_{st} – number of stroke, 2 stroke engine $N_{st}=1$, four stroke engine $N_{st}=2$.

Mass flow rate of diesel fuel in each cycle, is defined as:

$$\dot{m}_f = \frac{m N_{cyl} n_e}{60 N_{st}}. \quad (2)$$

On the basis of the determination of excess air, we can determine the average excess air ratio as the ratio of the air mass flowing into the cylinder, and fuel oil as the average of the mass flow. Because of the capture process, a part of fresh air enters the exhaust pipe of the exhaust system, so the flow of air into the cylinder cannot fully burn. The ratio of airflow through the purge air for combustion is called coefficient of purification. Therefore, if you want to calculate the exact rate, we should take into account the exchange ratio. Clearance rate is related to the angle of opening of the valve, so the air ratio can be redefined as follows:

$$\alpha = \frac{\dot{m}_{im}}{\dot{g}_f L_o \phi_s}, \quad (3)$$

where:

α – excess air coefficient,

ϕ_s – coefficient of scavenging,

\dot{m}_{im} – air mass flow,

\dot{g}_f – fuel mass flow,

$L_o = 14.3$, minimum air for complete combustion of 1 kg fuel.

Thermal efficiency

Equation (4) obtained by E. Hendricks, who appointed the indicated thermal efficiency due to the large amount of experimental data:

$$\eta_i = (a_1 + a_2 n_e + a_3 n_e^2)(1 - a_4 \alpha^{a_5}), \quad (4)$$

where $a_i=(1, 2, 3, 4)$ it is a constant related to the structure different engines. So the, the average indicated torque and exhaust gas temperature can be calculated as a movement:

$$T_i = \frac{30 P_i}{\pi n_e} = \frac{30 \cdot 10^3 \eta_i H_u \dot{m}_f}{\pi n_e}, \quad (5)$$

$$T_e = T_{im} + \frac{K}{1+L_o \alpha}. \quad (6)$$

Scavenging box

Scavenging box it depends on the mass and the law of conservation of energy, and the equation of state of ideal gas is shown below. Heat dissipation can be ignored.

$$\dot{p}_{im} = \frac{kR}{V_{im}} (\dot{m}_c T_s - \dot{m}_{in} T_{im}), \quad (7)$$

where:

- \dot{p}_{im} – pressure change rate in suction pipe,
- V_{im} – volume of suction pipe,
- k – rate of specific heat,
- R – gas constant,
- T_{im} – temperature in suction pipe,
- \dot{m}_c – flow of intercooler outlet,
- T_s – temperature of intercooler outlet,
- \dot{m}_{cin} – air flow into cylinder.

Compressor

On the basis of the ideal gas adiabatic compression, the rate of boost pressure, rotor speed, temperature, compressor outlet and torque are calculated as a flow:

$$T_{tc} = T_a \left\{ 1 + \frac{1}{\eta_c} [(\pi_k)^\mu - 1] \right\}, \quad (8)$$

$$T_c = \frac{\dot{m}_c c_p T_a}{\eta_c n_{tc}} [(\pi_k)^\mu - 1], \quad (9)$$

where:

- \dot{m}_c – air mass flow of compressor,
- η_c – efficiency of compressor,
- n_{tc} – rotor speed,
- π_k – boost pressure rate,
- T_a – suction temperature of compressor,
- T_{tc} – outlet temperature of compressor,
- T_c – absorbed torque of compressor,
- k_e – adiabatic index of air,
- c_p – specific heat at constant pressure.

Turbine

The turbine diesel engine may be simplified to the nozzle:

$$\dot{m}_t = \mu_t F_{TA} \Psi \frac{p_{em}}{\sqrt{RT_{em}}}, \quad (10)$$

where:

- μ – flow coefficient,
- F_{TA} – equivalent area of turbine nozzle,
- Ψ – flow function.

If $\pi_t \leq \left(\frac{k_e+1}{2}\right)^{\frac{k_e}{k_e-1}}$ when:

$$\psi = \sqrt{\frac{2k_e}{k_e-1} \left(\frac{p_b}{p_{em}}\right)^{\frac{2}{k_e}} \left[1 - \left(\frac{p_b}{p_{em}}\right)^{\frac{k_e-1}{k_e}}\right]}. \quad (11)$$

Otherwise, ψ does not change as the flow and pressure to attain maximum ψ_{max} :

$$\psi_{max} = \left(\frac{2}{k_e+1}\right)^{\frac{k_e}{k_e+1}} \sqrt{\frac{2k_e}{k_e+1}}, \quad (11)$$

where:

k_e – exhaust adiabatic index,

π_t – expand rate.

The torque of the turbine can be calculated as follows:

$$T_t = \frac{\dot{m}_t c_{pe} T_{em} \eta_t}{n_{tc}} \left[1 - \left(\frac{1}{\pi_t}\right)^{\frac{k_e}{k_e+1}}\right], \quad (12)$$

where:

T_t – compressor drive torque,

T_{em} – temperature of exhaust,

c_{pe} – specific heat at constant pressure of exhaust,

n_{te} – turbine efficiency rotor.

Rotor

Rotor model can be described as the second principle of Newton below:

$$\dot{n}_{tc} = \frac{\eta_m T_t - T_c}{J_{tc}} \frac{60}{2\pi}, \quad (13)$$

where:

J_{tc} – rotational inertia of rotor,

η_m – efficiency of turbine.

Air cooler

Pressure loss can be described as follows:

$$\Delta p_s = \eta_\gamma \frac{\dot{m}_c^2}{\rho_c}. \quad (14)$$

The compressor outlet pressure and temperature from the output of the radiator can be described as:

$$p_s = p_{im} + \Delta p_s, \quad (15)$$

$$T_s = T_{tc} - \eta_s (T_{tc} - T_{cwi}), \quad (16)$$

T_{cwi} – inlet temperature of cooling medium,

η_s – cooling efficiency.

Exhaust pipe

The model exhaust pipe of the diesel engine can be described by the equation:

$$\dot{p}_{em} = \frac{k_e R_e}{V_{em}} \left(\dot{m}_{out} T_e - \dot{m}_t T_{em} - \frac{\dot{Q}_{wem}}{c_{pe}} \right), \quad (17)$$

where:

\dot{p}_{em} – pressure change rate in exhaust,

R_e – exhaust gas constant,

K_e – exhaust adiabatic index,
 V_{em} – volume of exhaust pipe,
 \dot{m}_{out} – mass flow of exhaust,
 T_e – temperature of exhaust,
 \dot{m}_t – mass flow of turbine,
 T_{em} – temperature in exhaust pipe,
 \dot{Q}_{wem} – thermo flow.

Crankshaft and connecting rod dynamic model

Movement of the crankshaft, the connecting rod, and the instantaneous position of the crank shown in Fig. 3.

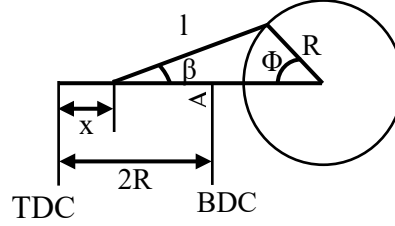

Fig. 3. Schematic diagram of the crankshaft

$\sin\beta = \lambda \sin\phi$, $\lambda = R / l$, so the displacement of the piston and the piston may be shown as equation

$$x = R \left[\left(1 + \frac{1}{\lambda}\right) - \frac{\sqrt{1 - \lambda^2 \sin^2\left(\frac{\pi n_e t}{30}\right)}}{\lambda} + \cos\left(\frac{\pi n_e t}{30}\right) \right], \quad (18)$$

$$x' = R \frac{\pi n_e}{30} \left(\frac{\lambda \sin\left(\frac{\pi n_e t}{15}\right)}{2\sqrt{1 - \lambda^2 \sin^2\left(\frac{\pi n_e t}{15}\right)}} + \sin\left(\frac{\pi n_e t}{15}\right) \right), \quad (19)$$

acceleration of the piston may be described as follows:

$$x'' = R \left(\frac{\pi n_e}{30}\right)^2 \left(\frac{\lambda \cos\left(\frac{\pi n_e t}{15}\right)}{2\sqrt{1 - \lambda^2 \sin^2\left(\frac{\pi n_e t}{30}\right)}} + \frac{\lambda^3 \sin^2\left(\frac{\pi n_e t}{15}\right)}{4(1 - \lambda^2 \sin^2\left(\frac{\pi n_e t}{30}\right))} + \cos\left(\frac{\pi n_e t}{30}\right) \right). \quad (20)$$

The gas pressure on the piston is calculated as follows:

$$F_g = \frac{\pi}{4} D^2 (p_z - p_s). \quad (21)$$

The force of inertia is as follows:

$$F_j = -m_j x'', \quad (22)$$

where m_j -crank and connecting rod reciprocating mass.

Analysis of the force is shown as follows:

$$F = F_g + F_j. \quad (23)$$

The balance of power in the crank (Fig. 4) the position of the crank at any angle Φ . For simplicity are ignored the friction of the piston cylinder liners and the friction of the piston pin and crank pin in the rod heads.

All kinds of forces can be described as follows:

$$F_L = \frac{F}{\cos\beta} = F / \sqrt{1 - \lambda^2 \sin^2\left(\frac{\pi n_e t}{30}\right)}, \quad (24)$$

$$F_N = F \frac{\lambda \sin\left(\frac{n\pi}{30}\right)t}{\sqrt{1 - \lambda^2 \sin^2\left(\frac{n\pi}{30}\right)t}}, \quad (25)$$

$$F_z = F_L \cos(\alpha + \beta) = F \left[\sqrt{1 - \lambda^2 \sin^2\left(\frac{n\pi}{30}\right)t} - \lambda \sin^2\left(\frac{n\pi}{30}\right)t \right], \quad (26)$$

$$F_N = F \left(\sin\left(\frac{n\pi}{30}\right)t \frac{\lambda \sin 2\left(\frac{n\pi}{30}\right)t}{2\sqrt{1 - \lambda^2 \sin^2\left(\frac{n\pi}{30}\right)t}} \right), \quad (27)$$

where:

F_L – connecting rod thrust,

F_N – side thrust,

F_z – normal force,

F_T – tangential force.

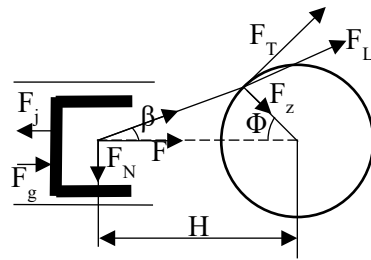

Fig. 4. Schematic distribution of forces on the crankshaft system

Governor

The regulator engine speed is modelled by a controller proportional-integral (PI). The position of the speed controller is calculated as follows:

$$x_r = x_{r,0} + K_p \Delta N + K_i \int_0^t \Delta N dt, \quad (28)$$

$$\Delta N = N_{ord} - N_E. \quad (29)$$

ΔN is the difference between the desired engine speed and actual engine speed. In addition, the torque and pressure are also included in the model motor controller as proposed and used by engine manufacturers to protect the integrity of the motor during fast transients.

Torque and exhaust temperature

The combustion process in the cylinder is very complicated, and the mathematical model of the volumetric method may not meet the requirements in real time. So the torque of the drive motor is calculated by:

$$T_i = \frac{30}{\pi} \cdot \frac{1000 \eta_i H_u \dot{m}_f}{n_e}, \quad (30)$$

where:

\dot{m}_f – injection flow of each cycle in one cylinder,

H_u – fuel lower calorific value,

η_i – indicated efficiency,

n_e – RPM of diesel engine.

The friction pressure loss can be described as a flow:

$$p_f = k_1 n_e + k_2 n_e^2, \quad (31)$$

where:

k_1, k_2 are constants related to engine structure.

The average friction torque can be described as follows:

$$T_f = \frac{10^3 V_d p_f}{2\pi N_{st}}, \quad (32)$$

where:

N_{st} – number of strokes of diesel engine.

Load torque can be described as follows:

$$T_p = K_p \rho n_e^2 D^5, \quad (33)$$

where:

K_p – propeller torque coefficient,

ρ – density of seawater,

D – diameter of propeller.

4. Conclusions

Many types of model "MVVM" can be found in the literature. Often presented models relate to the traction motors. Which are much faster than developed marine engines.

The quest for greater efficiency and for creates a friendly engines environment is an important factor in the development of models of diesel engines. Entering more and more electronics to the ship's engine enables the cell. However, the cost of creating prototype solutions for marine engines generates high production costs.

The more important it is to create physical models understandable to the motor, which can be implemented even in the engine control ship for selecting the optimal parameters for the diesel engine. Therefore, MVEM model is convenient because it can be used for many types of engine. Thanks to the modular design allows for easy upgrade model for the construction or the engine. With simple and compact mathematical no problem with the transfer equations for a programming language by reducing the time during the engine design.

References

- [1] Cao, Hui1, Wu Peili, Zhang, Jundong, *Modeling and Simulation of Working Process of Marine Diesel Engine with a Comprehensive Method*, International Journal of Computer Information Systems and Industrial Management Applications, Vol. 5, 2013.
- [2] Ciesielski, S., *Okrętowe tłokowe silniki spalinowe, Procesy wewnętrzne*, Akademia Marynarki Wojennej, Gdynia 2007
- [3] Hai, Wu, *Performance simulation and control design for diesel engine NOx emission reduction technologies*, University of Illinois, Urbana, Illinois 2011.
- [4] Hendricks, E., *Engine Modelling for Control Applications: A Critical Survey*, Meccanica 32 Kluwer Academic Publishers, Netherlands 1997.
- [5] Jędrzejowski, J., *Obliczanie tłokowego silnika spalinowego*, Wydawnictwo Naukowo-Techniczne, Warszawa 1971.
- [6] Theotokatos, G. P., *A Comparative Study on Mean Value Modelling of Two-Stroke Marine Diesel Engine*, Proceedings of the 2nd International Conference on Maritime and Naval Science and Engineering.
- [7] Turesson, M, *Modelling and simulation of a two-stroke engine*, Chalmers University of Technology Göteborg, Sweden 2009.