

ANALYTICAL MODEL OF THE TWO-MASS ABOVE RESONANCE SYSTEM OF THE ECCENTRIC-PENDULUM TYPE VIBRATION TABLE

O.S. LANETS, V.T. DMYTRIV* and V.M. BOROVETS

Lviv Polytechnic National University, Institute of Engineering Mechanics and Transport
Department of Mechanics and Automation of Mechanical Engineering
Lviv, 79013, UKRAINE

E-mails : poslanets1@gmail.com; Dmytriv_V@ukr.net; volbor1@gmail.com

I.A. DEREVENKO

Lviv Polytechnic National University, Institute of Civil Engineering and Building Systems
Department of Strength of Materials and Structural Mechanics
Lviv, 79013, UKRAINE

E-mail: i.a.derevenko@gmail.com

I.M. HORODETSKYI

Lviv National Agrarian University, Faculty of Mechanic and Power Engineering
Department of Project Management and Occupational Safety
Lviv-Dubliany, 80381, UKRAINE

E-mail:ivanhorod@gmail.com

The article deals with a two-mass above resonant oscillatory system of an eccentric-pendulum type vibrating table. Based on the model of a vibrating oscillatory system with three masses, the system of differential equations of motion of oscillating masses with five degrees of freedom is compiled using generalized Lagrange equations of the second kind. For given values of mechanical parameters of the oscillatory system and initial conditions, the autonomous system of differential equations of motion of oscillating masses is solved by the numerical Rosenbrock method. The results of analytical modelling are verified by experimental studies. The two-mass vibration system with eccentric-pendulum drive in resonant oscillation mode is characterized by an instantaneous start and stop of the drive without prolonged transient modes. Parasitic oscillations of the working body, as a body with distributed mass, are minimal at the frequency of forced oscillations.

Key words: two-mass system, eccentric-pendulum drive, Lagrange equation, Rosenbrock method, vibration.

1. Introduction

Vibration machines have become widely used in various fields of production and engineering, which is confirmed by research of Bednarski *et al.* [1], Filimonikhin *et al.* [2], Nadutyi *et al.* [3]. This indicates the relevance and current importance of the use of vibration technique.

Researchers, e.g., Babitsky [4], Luo [5] and Sokolov [6], claim that a significant number of vibration machines are vibration-shock type, which are in the category of nonlinear machines and can operate in both non-resonant and resonant modes.

The influence of own frequencies in the resonance and above resonance range of the connected system and the dynamic character of the system at the presence of applied oscillatory loads are among the most important issues in the design of various-purpose hardware and engineering tools. Usually, in such

*To whom correspondence should be addressed

systems, the working element is a base plate–table, or a plate in the form of a plane of a given configuration and geometric dimensions.

Tymoshenko's beam and plate studies have become wide spread. The linear and nonlinear parameters of the main frequency of the conical beams of Tymoshenko were determined by Rajesh *et al.* [7] with the method of the interconnected bias field; closed-form dependencies were derived as a ratio often in the form of functions of the flexibility coefficient, the coefficients of the maximum amplitude for boundary conditions with the hinged beam. ANSYS Parametric Design Language was used by Gharaibeh *et al.* [8] to create finite element models and calculate the first intrinsic frequency of the plate and the mode shape. Joubaneh *et al.* [9] performed a vibration analysis of the sandwich panels, and the master equations for the motion were obtained by Hamilton's principle with using the generalized differential quadrature method (GDQ). Also, these authors simulated in SolidWorks and experimented with free and forced vibration at different boundary conditions. Xianjie *et al.* [10] calculated the shift and forms of mode by a numerical method for a T-shaped plate using the Rayleigh – Ritz procedure for free and forced oscillations. These studies relate to beams and plates, which are elements of a single mass system with a given number of fixed points rigidly or elastically.

Mirzabeigy *et al.* [11] investigated the free vibration of a two-mass system with nonlinear connection. Using the energy balance method based on the Galerkin – Petrov mathematical method these authors obtained amplitude-frequency dependencies for the generalized Duffing equation of vibration wave. The studies were theoretical. Panovko *et al.* [12] experimentally investigated the dynamics of the model of a serial two-mass oscillatory system with two unbalanced vibration exciters. The same authors analysed the effect of changes in the frequency of deviations of synchronous rotation on the forms of vibration of the carrier body and the mutual phase shift of imbalances. Jia-Jang Wu [13] investigated the system by replacing each elastic-mass system with three degrees of freedom by means of set of equivalent masses so that the dynamic characteristics of a rectangular plate (or main structure) with any number of elastic fixed masses with concentrated parameters could be obtained from the same plate containing identical sets of rigidly attached equivalent masses. This method can be applied to the numerical procedure of solution of the system.

Vera *et al.* [14] investigated a system consisting of a plate and an elastically mounted additional mass with two degrees of freedom. The authors simulated an analytical model based on Lagrange multipliers, analyzed the shapes of modes with different design configurations and vibrational frequencies. Gursky *et al.* [15] carried out a complex dynamic analysis of a vibration shock system according to analytical dependencies based on the rod system and calculated the natural frequency of free oscillations and contact stiffness by the finite element method. The same authors simulated the bending of system elements. Gorman *et al.* [16-20] applied the method of superposition and experimentally investigated free oscillations of different sizes and designs of rectangular plates with different boundary conditions, point supports and with partially bounded edges. Abrahams *et al.* [21, 22] investigated plates fixed at one edge, with static or dynamic loads; the other edge had mixed boundary conditions. The task was reduced by these authors to the Wiener-Hopf matrix equation, which was solved by an approximate factorization scheme.

In the open literature sources there is a lack of quantitative analysis regarding the effect of plate sizes and boundary conditions properties on the characteristics of vibration of rectangular plates, both free oscillations and forced. The above analysis shows that the relevant task of theoretical and experimental nature is to develop an analytical model of a two-mass above resonance system for practical use on the specific equipment with a mechanical vibration excitor, in particular of the eccentric-pendulum type.

2. Description of the problem

The schematic diagram of the proposed vibration table of the eccentric pendulum type is given. Working body (1) is mounted on a fixed base through vibroisolating elastic elements (2) (elements with low rigidity in the vertical direction). In the frame of the working body the drive shaft (3) is installed, on which the pendulum (4) is spindled with eccentricity of ε . The asynchronous electromotor (6) drives the shaft (3) through the petal coupling of (5). Due to the rotational motion of the shaft with a rate speed ω , the F_0 excitation force vector arises and drives the oscillatory system. The mass of m_1 is oscillated in counter-phase to the pendulum of m_3 mass. By mass of m_1 we mean the mass of the (m_{wb}) working body with particle of

$k_{elast} \cdot m_{load}$ mass of the load ratio. The working body takes this mass as fully attached to it during vibration.

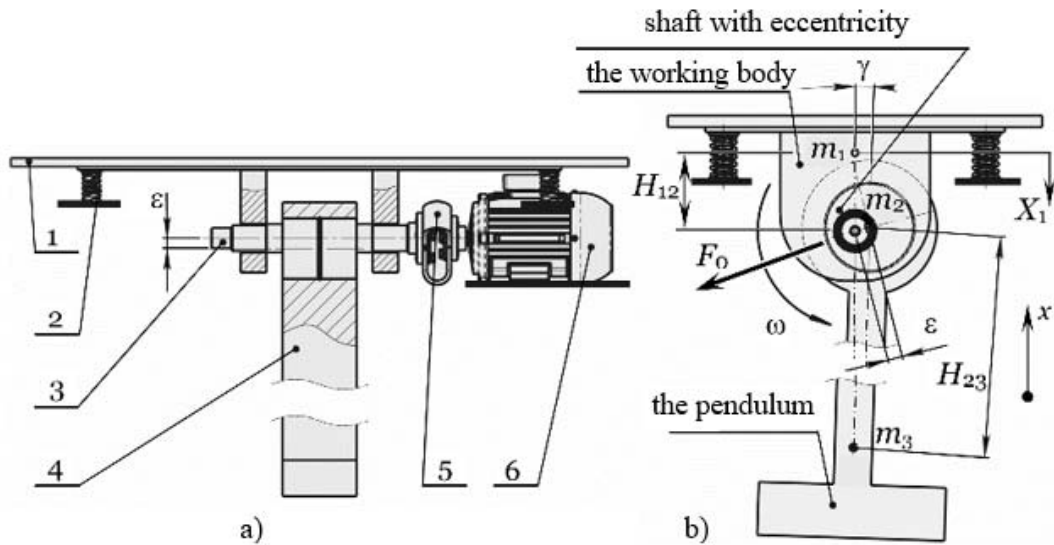

Fig.1. Schematic diagram of the vibration table of the eccentric-pendulum type: (a) side view and (b) front.

This is a two-mass above resonance oscillating system. The center of mass of the pendulum is lowered on H_{23} relative to the axis of rotation of the shaft, the transmission of force to the working body in the vertical direction is complete, in the horizontal direction - partial (the lower the center of mass of the pendulum relative to the axis of rotation of the shaft, the smaller the power transmission in the horizontal direction). The angle of deviation γ of the pendulum is small.

The structural solution of the working body provides high rigidity of the design at rather small weight. The first natural frequency of the working body is $\nu_1 \approx 200$ [Hz] (Fig.2), which is four times higher than the forced $\nu_e = 50$ [Hz]. Accordingly, the parasitic oscillations of the working body, as a body with distributed mass, will be minimal at the frequency of forced oscillations.

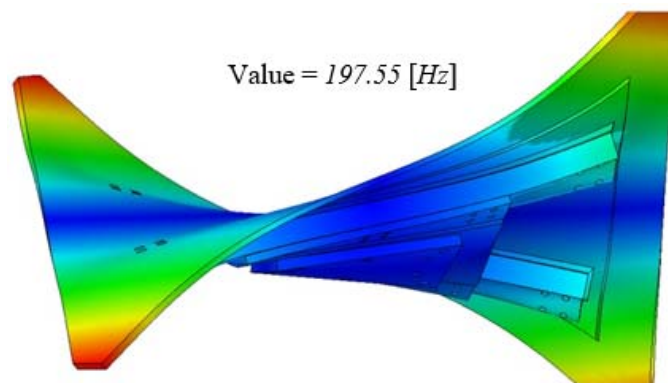

Fig.2. The first natural frequency of oscillations of the working body as a body with distributed mass (table dimensions of 1200×900 mm), according to the method of finite elements in environment of the CosmosWorks module in SolidWorks software.

The aim of the study is to develop a mathematical model based on analytical modelling of the characteristics of a two-mass above resonant oscillatory system at generalized coordinates and to design parameters of structural elements of vibrating tables for practical implementation of vibration technologies.

2. Analytical model of a two-mass above resonance system of the vibrating table

2.1. Physical model of a vibrating machine

Consider a plane model of a vibrating machine, sufficient for its mathematical description. We establish the basic coordinate system of xyz , the xy plane of which passes perpendicular to the axis of rotation of the shaft with eccentricity, and the y -axis is directed vertically (Fig.3). The z axis coincides with the center of m_1 mass.

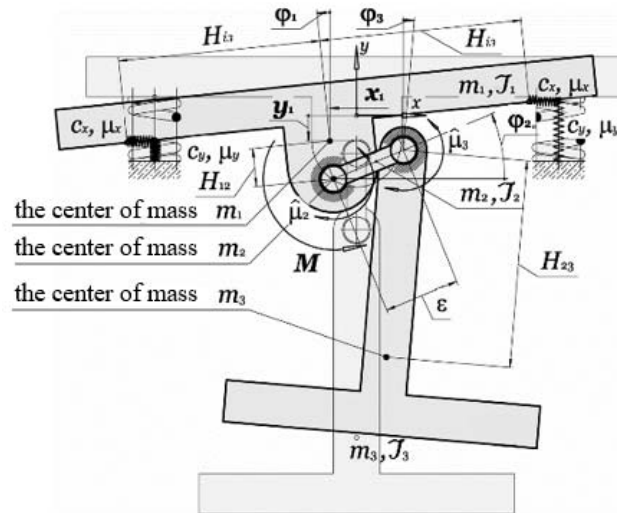

Fig.3. Physical model of a vibrating table.

The mechanical oscillating system consists of three absolutely rigid bodies: a working body of mass m_1 with a J_1 moment of inertia relative to the axis passing through the center of its mass perpendicular to the xy plane; an eccentric shaft of m_2 mass with a J_2 moment of inertia for the axis of rotation and a pendulum of m_3 mass with a J_3 moment of inertia relative to the axis passing through the center of its mass perpendicular to the plane of xy . J_2 takes into account the moment of inertia of the electric motor rotor, in contrast to the m_2 parameter, which does not take into account the mass of the rotor. Such connection is provided by the petal coupling, on axes of x - y the mechanical linkage is provided between the shaft and the electric motor which practically does not transfer oscillating movement of the working body on these axes on the rotor of the electric motor.

The plane or two-dimensional model of the vibrating machine consists of three bodies connected by two kinematic pairs of the fifth order. In this case, the motion of the system can be described by five independent coordinates: the oscillation of the m_1 mass along the x , y axes and around its own center of mass in the xy plane, respectively, by the generalized coordinates of x_1 , y_1 and φ_1 ; rotational motion of m_2 and m_3 masses around their own centers of mass in the xy plane by generalized coordinates of φ_2 and φ_3 . Additionally, we consider the generalized coordinate to be the M moment of excitation of the electric motor. The oscillating system has six degrees of freedom. The plane mechanism has three solids ($n = 3$) connected by two kinematic pairs of the first kind ($p = 2$), in this case the number of degrees of its mobility is defined as $3n - 2p = 3 \cdot 3 - 2 \cdot 2 = 5$.

The distance from the center of m_1 mass to the axis of the shaft is denoted by H_{12} , and from the center of eccentricity to the center of mass m_3 as H_{23} . The horizontal distance from the vibration isolators to the center of mass of the working body is denoted as H_{13} . The oscillating system is mounted on a fixed base through vibration isolators attached from below to the working body, and their stiffness coefficients along the x and y axes are c_x and c_y , respectively.

To take into account the influence of the medium, we introduce the coefficients of viscous friction

that are proportional to the velocity. The coefficients μ_x and μ_y determine the energy dissipation in the vibration isolators during the movement of the m_1 mass along the x and y axes, respectively. Coefficients μ_x and μ_y we will be considered as a complex indicator that additionally also takes into account the viscous resistance caused by the influence of the m_{306} mass of the loading medium. The coefficient $\hat{\mu}_2$ reflects the viscous friction in the bearings between the working body and the shaft (between masses of m_1 and m_2), and $\hat{\mu}_3$ – between the shaft and the pendulum (between masses m_2 and m_3).

2.2. Development of the analytical model of the oscillating system

We write the linear and angular coordinates of each of the masses m_1 , m_2 and m_3 for the scheme of the vibrating table according to Fig.3. After deviation from the equilibrium position of the center of m_1 mass, we will write the coordinates of the center of m_1 mass along the x and y axes as

$$(x_1) \quad \text{and} \quad (y_1). \quad (2.1)$$

The angular deviation of m_1 mass from the natural center of mass and mass of m_2 and m_3 around the natural centers of mass we can write respectively as

$$\varphi_1; \quad \varphi_2 \quad \text{and} \quad (-\varphi_3). \quad (2.2)$$

Coordinates (2.1) and (2.2) are generalized. The linear coordinates of centers of mass m_2 and m_3 are determined through the generalized coordinates as follows

$$\begin{aligned} x_2 &= -x_1 + H_{12} \sin \phi_1; & x_3 &= -x_1 + H_{12} \sin \phi_1 + \varepsilon \cos \phi_2 - H_{23} \sin \phi_3; \\ y_2 &= -y_1 - H_{12} \cos \phi_1; & y_3 &= -y_1 - H_{12} \cos \phi_1 + \varepsilon \sin \phi_2 - H_{23} \cos \phi_3. \end{aligned} \quad (2.3)$$

We have nine coordinates that fully describe the motion of three oscillating masses in a plane. Since the angular oscillations of the working body (mass m_1) and the pendulum (mass m_3) around their own centers of mass are small, to simplify further calculations we use the following approximations: $\sin \varphi_{1,2} \approx \varphi_{1,2}$, $\cos \varphi_{1,2} \approx 1$, which are fulfilled at small values of $\varphi_{1,2}$. Then above coordinates (2.3) of the centers of mass m_2 and m_3 will take the form of

$$\begin{aligned} x_2 &= -x_1 + H_{12} \phi_1; & x_3 &= -x_1 + H_{12} \phi_1 + \varepsilon \cos \phi_2 - H_{23} \phi_3; \\ y_2 &= -y_1 - H_{12}; & y_3 &= -y_1 - H_{12} + \varepsilon \sin \phi_2 - H_{23}. \end{aligned} \quad (2.4)$$

Let us find the time derivatives of the coordinates of the masses m_1 , m_2 and m_3

$$\begin{aligned} \dot{x}_1 &= -\dot{x}_1; & \dot{y}_1 &= -\dot{y}_1; & \dot{\phi}_1 &= -\dot{\phi}_1; \\ \dot{x}_2 &= -\dot{x}_1 + H_{12} \dot{\phi}_1; \\ \dot{y}_2 &= -\dot{y}_1; & \dot{\phi}_2 &= \dot{\phi}_2; \\ \dot{x}_3 &= -\dot{x}_1 + H_{12} \dot{\phi}_1 - \varepsilon \dot{\phi}_2 \sin \phi_2 - H_{23} \dot{\phi}_3; \\ y_3 &= -\dot{y}_1 + \varepsilon \dot{\phi}_2 \cos \phi_2; & \dot{\phi}_3 &= -\dot{\phi}_3. \end{aligned} \quad (2.5)$$

The system of differential equations of motion of oscillatory masses for five degrees of freedom will be compiled using generalized Lagrange equations of the second kind

$$\left\{ \begin{array}{l} \frac{d}{dt} \left(\frac{\partial K}{\partial \dot{x}_1} \right) - \frac{\partial K}{\partial x_1} + \frac{\partial P}{\partial x_1} + \frac{\partial D}{\partial \dot{x}_1} = F_{x_1}; \quad \frac{d}{dt} \left(\frac{\partial K}{\partial \dot{y}_1} \right) - \frac{\partial K}{\partial y_1} + \frac{\partial P}{\partial y_1} + \frac{\partial D}{\partial \dot{y}_1} = F_{y_1}; \\ \frac{d}{dt} \left(\frac{\partial K}{\partial \dot{\phi}_1} \right) - \frac{\partial K}{\partial \phi_1} + \frac{\partial P}{\partial \phi_1} + \frac{\partial D}{\partial \dot{\phi}_1} = F_{\phi_1}; \quad \frac{d}{dt} \left(\frac{\partial K}{\partial \dot{\phi}_2} \right) - \frac{\partial K}{\partial \phi_2} + \frac{\partial P}{\partial \phi_2} + \frac{\partial D}{\partial \dot{\phi}_2} = F_{\phi_2}; \\ \frac{d}{dt} \left(\frac{\partial K}{\partial \dot{\phi}_3} \right) - \frac{\partial K}{\partial \phi_3} + \frac{\partial P}{\partial \phi_3} + \frac{\partial D}{\partial \dot{\phi}_3} = F_{\phi_3}, \end{array} \right. \quad (2.6)$$

where K , P , D - respectively the kinetic and potential energy and the energy dissipation function in the system;

$F_{x_1}, F_{y_1}, F_{\phi_1}, F_{\phi_2}, F_{\phi_3}$ –generalized forces according to the corresponding linear and angular coordinates.

We solve the system by numerical calculation using the Maple software environment. We perform intermediate character transformations.

We determine the total kinetic energy K of the system, which is equal to the sum of the kinetic energies of the masses m_1 , m_2 and m_3 , be

$$K = K_1 + K_2 + K_3. \quad (2.7)$$

The masses are in plane or two-dimensional motion. Now then

$$K_1 = \frac{m_1 \dot{x}_1^2}{2} + \frac{m_1 \dot{y}_1^2}{2} + \frac{J_1 \dot{\phi}_1^2}{2}; \quad K_2 = \frac{m_2 \dot{x}_2^2}{2} + \frac{m_2 \dot{y}_2^2}{2} + \frac{J_2 \dot{\phi}_2^2}{2}; \quad K_3 = \frac{m_3 \dot{x}_3^2}{2} + \frac{m_3 \dot{y}_3^2}{2} + \frac{J_3 \dot{\phi}_3^2}{2}. \quad (2.8)$$

The corresponding expressions for derivatives of Eqs (2.5) were substituted into Eqs (2.8) and after simplification, we obtained

$$\begin{aligned} K_1 &= \frac{1}{2} m_1 \dot{x}_1^2 + \frac{1}{2} m_1 \dot{y}_1^2 + \frac{1}{2} J_1 \dot{\phi}_1^2; \\ K_2 &= \frac{1}{2} m_2 H_{12}^2 \dot{\phi}_1^2 - m_2 H_{12} \dot{\phi}_1 \dot{x}_1 + \frac{1}{2} m_2 \dot{x}_1^2 + \frac{1}{2} m_2 \dot{y}_1^2 + \frac{1}{2} J_2 \dot{\phi}_2^2; \\ K_3 &= \frac{1}{2} m_3 \dot{x}_1^2 - m_3 H_{12} \dot{\phi}_1 \dot{x}_1 + m_3 \dot{x}_1 \varepsilon \dot{\phi}_2 \sin \phi_2 + m_3 \dot{x}_1 H_{23} \dot{\phi}_3 + \frac{1}{2} m_3 H_{12}^2 \dot{\phi}_1^2 + \\ &- m_3 H_{12} \dot{\phi}_1 \dot{\phi}_2 \varepsilon \sin \phi_2 - m_3 H_{12} \dot{\phi}_1 H_{23} \dot{\phi}_3 + \frac{1}{2} m_3 \varepsilon^2 \dot{\phi}_2^2 + m_3 H_{23} \dot{\phi}_2 \dot{\phi}_3 \varepsilon \sin \phi_2 + \\ &+ \frac{1}{2} m_3 H_{23}^2 \dot{\phi}_3^2 + \frac{1}{2} m_3 \dot{y}_1^2 - m_3 \dot{y}_1 \varepsilon \dot{\phi}_2 \cos \phi_2 + \frac{1}{2} J_3 \dot{\phi}_3^2. \end{aligned} \quad (2.9)$$

Therefore, the total kinetic energy of system (2.7) after summing of expressions (2.9) will be

$$\begin{aligned}
K = & \frac{1}{2}(m_1 + m_2 + m_3)(\dot{x}_1^2 + \dot{y}_1^2) + \frac{1}{2}(J_1 + m_2 H_{12}^2 + m_3 H_{12}^2)\dot{\phi}_1^2 + \\
& + \frac{1}{2}(J_2 + m_3 \varepsilon^2)\dot{\phi}_2^2 + \frac{1}{2}(J_3 + m_3 H_{23}^2)\dot{\phi}_3^2 - m_2 H_{12} \dot{\phi}_1 \dot{x}_1 - m_3 H_{12} \dot{\phi}_1 \dot{x}_1 + \\
& + m_3 \dot{x}_1 H_{23} \dot{\phi}_3 + m_3 \dot{x}_1 \varepsilon \dot{\phi}_2 \sin \phi_2 - m_3 H_{12} \dot{\phi}_1 \dot{\phi}_2 \varepsilon \sin \phi_2 - m_3 H_{12} \dot{\phi}_1 H_{23} \dot{\phi}_3 + \\
& + m_3 H_{23} \dot{\phi}_2 \dot{\phi}_3 \varepsilon \sin \phi_2 - m_3 \dot{y}_1 \varepsilon \dot{\phi}_2 \cos \phi_2.
\end{aligned} \tag{2.10}$$

Using Eq.(2.10), we calculate the derivatives of the kinetic energy K by velocities

$$\begin{aligned}
\frac{\partial K}{\partial \dot{x}_1} &= \dot{x}_1(m_1 + m_2 + m_3) - (m_2 + m_3)H_{12}\dot{\phi}_1 + m_3\dot{\phi}_2\varepsilon\sin\phi_2 + m_3H_{23}\dot{\phi}_3; \\
\frac{\partial K}{\partial \dot{y}_1} &= \dot{y}_1(m_1 + m_2 + m_3) - m_3\varepsilon\dot{\phi}_2\cos\phi_2; \\
\frac{\partial K}{\partial \dot{\phi}_1} &= (J_1 + m_2H_{12}^2 + m_3H_{12}^2)\dot{\phi}_1 - (m_2 + m_3)H_{12}\dot{x}_1 - m_3H_{12}\varepsilon\dot{\phi}_2\sin\phi_2 - m_3H_{12}H_{23}\dot{\phi}_3; \\
\frac{\partial K}{\partial \dot{\phi}_2} &= (J_2 + m_3\varepsilon^2)\dot{\phi}_2 + m_3\dot{x}_1\varepsilon\sin\phi_2 - m_3H_{12}\dot{\phi}_1\varepsilon\sin\phi_2 + m_3\varepsilon H_{23}\dot{\phi}_3\sin\phi_2 - m_3\dot{y}_1\varepsilon\cos\phi_2; \\
\frac{\partial K}{\partial \dot{\phi}_3} &= (J_3 + m_3H_{23}^2)\dot{\phi}_3 + m_3\dot{x}_1H_{23} - m_3H_{12}H_{23}\dot{\phi}_1 + m_3\varepsilon H_{23}\dot{\phi}_2\sin\phi_2.
\end{aligned} \tag{2.11}$$

We determine the derivatives of kinetic energy Eq.(2.10) by generalized coordinates

$$\begin{aligned}
\frac{\partial K}{\partial x_1} = 0; \quad \frac{\partial K}{\partial y_1} = 0; \quad \frac{\partial K}{\partial \phi_1} = 0; \quad \frac{\partial K}{\partial \phi_3} = 0; \\
\frac{\partial K}{\partial \phi_2} = m_3\varepsilon\dot{x}_1\dot{\phi}_2\cos\phi_2 - m_3H_{12}\varepsilon\dot{\phi}_1\dot{\phi}_2\cos\phi_2 + m_3\varepsilon H_{23}\dot{\phi}_2\dot{\phi}_3\cos\phi_2 + m_3\varepsilon\dot{y}_1\dot{\phi}_2\sin\phi_2.
\end{aligned} \tag{2.12}$$

We calculate the time derivatives of dependencies (2.11)

$$\begin{aligned}
\frac{d}{dt}\left(\frac{\partial K}{\partial \dot{x}_1}\right) &= \ddot{x}_1(m_1 + m_2 + m_3) - (m_2 + m_3)H_{12}\ddot{\phi}_1 + m_3\varepsilon(\dot{\phi}_2^2\cos\phi_2 + \ddot{\phi}_2\sin\phi_2) + m_3H_{23}\ddot{\phi}_3; \\
\frac{d}{dt}\left(\frac{\partial K}{\partial \dot{y}_1}\right) &= \ddot{y}_1(m_1 + m_2 + m_3) + m_3\varepsilon(\dot{\phi}_2^2\sin\phi_2 - \ddot{\phi}_2\cos\phi_2); \\
\frac{d}{dt}\left(\frac{\partial K}{\partial \dot{\phi}_1}\right) &= (J_1 + m_2H_{12}^2 + m_3H_{12}^2)\ddot{\phi}_1 - (m_2 + m_3)H_{12}\ddot{x}_1 - \\
& - m_3H_{12}\varepsilon(\dot{\phi}_2^2\cos\phi_2 + \ddot{\phi}_2\sin\phi_2) - m_3H_{12}H_{23}\ddot{\phi}_3; \\
\frac{d}{dt}\left(\frac{\partial K}{\partial \dot{\phi}_2}\right) &= (J_2 + m_3\varepsilon^2)\ddot{\phi}_2 + m_3\varepsilon(\ddot{x}_1\sin\phi_2 + \dot{x}_1\dot{\phi}_2\cos\phi_2 + \dot{y}_1\dot{\phi}_2\sin\phi_2 - \ddot{y}_1\cos\phi_2) + \\
& - m_3H_{12}\varepsilon(\ddot{\phi}_1\sin\phi_2 + \dot{\phi}_1\dot{\phi}_2\cos\phi_2) + m_3H_{23}\varepsilon(\ddot{\phi}_3\sin\phi_2 + \dot{\phi}_2\dot{\phi}_3\cos\phi_2); \\
\frac{d}{dt}\left(\frac{\partial K}{\partial \dot{\phi}_3}\right) &= m_3H_{23}\ddot{x}_1 - m_3H_{12}H_{23}\ddot{\phi}_1 + m_3H_{23}\varepsilon(\dot{\phi}_2^2\cos\phi_2 + \ddot{\phi}_2\sin\phi_2) + (J_3 + m_3H_{23}^2)\ddot{\phi}_3.
\end{aligned} \tag{2.13}$$

We determine the potential energy of the system, as well as its derivatives by independent coordinates. It will be determined only by the potential energy of the elastic elements. For the zero level we take the equilibrium position of the system when the system is at idle state. Now then

$$P = \frac{c_x x_l^2}{2} + \frac{c_y (y_l + H_{i3} \phi_l)^2}{2} + \frac{c_x x_l^2}{2} + \frac{c_y (y_l - H_{i3} \phi_l)^2}{2}. \quad (2.14)$$

Simplifying of Eq.(2.14), we obtain

$$P = c_x x_l^2 + c_y y_l^2 + c_y H_{i3}^2 \phi_l^2. \quad (2.15)$$

Derivatives in generalized coordinates from function of Eq.(2.15) are such

$$\frac{\partial P}{\partial x_l} = 2c_x x_l; \quad \frac{\partial P}{\partial y_l} = 2c_y y_l; \quad \frac{\partial P}{\partial \phi_l} = 2c_y H_{i3}^2 \phi_l; \quad \frac{\partial P}{\partial \phi_2} = 0; \quad \frac{\partial P}{\partial \phi_3} = 0. \quad (2.16)$$

Let us determine the D energy dissipation function proportional to the velocity

$$D = \frac{\mu_x \dot{x}_l^2}{2} + \frac{\mu_y (\dot{y}_l + H_{i3} \dot{\phi}_l)^2}{2} + \frac{\mu_x \dot{x}_l^2}{2} + \frac{\mu_y (\dot{y}_l - H_{i3} \dot{\phi}_l)^2}{2} + \frac{\hat{\mu}_2 (\dot{\phi}_l - \dot{\phi}_2)^2}{2} + \frac{\hat{\mu}_3 (\dot{\phi}_2 - \dot{\phi}_3)^2}{2}. \quad (2.17)$$

Simplifying Eq.(2.17), we obtain

$$D = \mu_x \dot{x}_l^2 + \mu_y \dot{y}_l^2 + \mu_y H_{i3}^2 \dot{\phi}_l^2 + \frac{1}{2} \hat{\mu}_2 \dot{\phi}_l^2 - \hat{\mu}_2 \dot{\phi}_l \dot{\phi}_2 + \frac{1}{2} \hat{\mu}_2 \dot{\phi}_2^2 + \frac{1}{2} \hat{\mu}_3 \dot{\phi}_2^2 - \hat{\mu}_3 \dot{\phi}_2 \dot{\phi}_3 + \frac{1}{2} \hat{\mu}_3 \dot{\phi}_3^2. \quad (2.18)$$

Derivatives of generalized velocities of function (2.18) will be

$$\frac{\partial D}{\partial \dot{x}_l} = 2\mu_x \dot{x}_l; \quad \frac{\partial D}{\partial \dot{y}_l} = 2\mu_y \dot{y}_l; \quad \frac{\partial D}{\partial \dot{\phi}_l} = 2\mu_y H_{i3}^2 \dot{\phi}_l + \hat{\mu}_2 (\dot{\phi}_l - \dot{\phi}_2); \quad (2.19)$$

$$\frac{\partial D}{\partial \dot{\phi}_2} = \hat{\mu}_2 (\dot{\phi}_2 - \dot{\phi}_l) + \hat{\mu}_3 (\dot{\phi}_2 - \dot{\phi}_3); \quad \frac{\partial D}{\partial \dot{\phi}_3} = \hat{\mu}_3 (\dot{\phi}_3 - \dot{\phi}_2).$$

We determine the generalized forces for each of the generalized coordinates, the force of gravity is considered as the force of excitation

$$F_{x_l} = F_{y_l} = 0; \quad F_{\phi_l} = -m_3 g H_{i2} \sin \phi_l - m_3 g \varepsilon \cos \phi_2 \cos \phi_3; \quad (2.20)$$

$$F_{\phi_2} = M - m_3 g \varepsilon \cos \phi_2 \cos \phi_3; \quad F_{\phi_3} = -m_3 g H_{23} \sin \phi_3$$

where M – engine torque, which depends on the angular velocity of the rotor (coordinate ϕ_2); g – acceleration of gravity.

We connect the functions M and ϕ_2 using the equation of an induction motor, Shatokhin [23]. Considering dependencies Eqs (2.12), (2.13), (2.16), (2.19) and (2.20), system (2.6) is written as

$$\begin{aligned}
& (m_1 + m_2 + m_3)\ddot{x}_1 - (m_2 + m_3)\ddot{H}_{12}\ddot{\phi}_1 + m_3\varepsilon\left(\dot{\phi}_2^2 \cos \varphi_2 + \ddot{\phi}_2 \sin \varphi_2\right) + \\
& + m_3 H_{23}\ddot{\phi}_3 + 2c_x x_1 + 2\mu_x \dot{x}_1 = 0 ; \\
& (m_1 + m_2 + m_3)\ddot{y}_1 + m_3\varepsilon\left(\dot{\phi}_2^2 \sin \varphi_2 - \ddot{\phi}_2 \cos \varphi_2\right) + 2c_y y_1 + 2\mu_y \dot{y}_1 = 0 ; \\
& \left(J_1 + m_2 H_{12}^2 + m_3 H_{12}^2\right)\ddot{\phi}_1 - (m_2 + m_3)H_{12}\ddot{x}_1 - m_3 H_{12}\varepsilon\left(\dot{\phi}_2^2 \cos \varphi_2 + \ddot{\phi}_2 \sin \varphi_2\right) + \\
& - m_3 H_{12} H_{23}\ddot{\phi}_3 + 2c_y H_{i3}^2 \phi_1 + 2\mu_y H_{i3}^2 \dot{\phi}_1 + \hat{\mu}_2 (\dot{\phi}_1 - \dot{\phi}_2) = \\
& = -m_3 g H_{12} \sin \varphi_1 - m_3 g \varepsilon \cos \varphi_2 \cos \varphi_3 ; \tag{2.21} \\
& \left(J_2 + m_3 \varepsilon^2\right)\ddot{\phi}_2 + m_3\varepsilon\left(\ddot{x}_1 \sin \varphi_2 - \ddot{y}_1 \cos \varphi_2\right) - m_3 H_{12}\varepsilon\ddot{\phi}_1 \sin \varphi_2 + m_3 H_{23}\varepsilon\ddot{\phi}_3 \sin \varphi_2 + \\
& + \hat{\mu}_2 (\dot{\phi}_2 - \dot{\phi}_1) + \hat{\mu}_3 (\dot{\phi}_2 - \dot{\phi}_3) = M - m_3 g \varepsilon \cos \varphi_2 \cos \varphi_3 ; \\
& \left(J_3 + m_3 H_{23}^2\right)\ddot{\phi}_3 + m_3 H_{23}\ddot{x}_1 - m_3 H_{12} H_{23}\ddot{\phi}_1 + m_3 H_{23}\varepsilon\left(\dot{\phi}_2^2 \cos \varphi_2 + \ddot{\phi}_2 \sin \varphi_2\right) + \\
& + \hat{\mu}_3 (\dot{\phi}_3 - \dot{\phi}_2) = -m_3 g H_{23} \sin \varphi_3 ; \\
& -\frac{2M_{\max}(\omega_0 - \dot{\phi}_2)}{\left(1 + \frac{(\omega_0 - \dot{\phi}_2)^2}{\omega_0^2}\right)\omega_0} + \frac{T_D \dot{M}}{1 + \frac{(\omega_0 - \dot{\phi}_2)^2}{\omega_0^2}} + \frac{T_D \left(2 + \frac{T_D \ddot{\phi}_2}{\omega_0 - \dot{\phi}_2}\right) \dot{M}}{1 + \frac{(\omega_0 - \dot{\phi}_2)^2}{\omega_0^2}} + \\
& + \left(1 + \frac{T_D \ddot{\phi}_2}{\left(1 + \frac{(\omega_0 - \dot{\phi}_2)^2}{\omega_0^2}\right)(\omega_0 - \dot{\phi}_2)}\right) M = 0.
\end{aligned}$$

3. Results and discussions

3.1. Results of mathematical simulation

The values of mechanical parameters of the oscillatory system included in the developed mathematical model (2.21) are as follows

$$c_x = 17500[N/m], \quad c_y = 22500[N/m], \quad \varepsilon = 0.001[m], \quad g = 9.81[kg \cdot m/s^2],$$

$$H_{12} = 0.125[m], \quad H_{23} = 0.41[m], \quad H_{i3} = 0.32[m],$$

$$J_1 = 13.54[kg \cdot m^2], \quad J_2 = 0.03[kg \cdot m^2], \quad J_3 = 7.8[kg \cdot m^2],$$

$$m_1 = 293[kg], \quad m_2 = 20[kg], \quad m_3 = 153.8[kg],$$

$$M_{max} = 18.7[N \cdot m], \quad \hat{\mu}_2 = 0.007[N \cdot m \cdot s / rad], \quad \hat{\mu}_3 = 0.0035[N \cdot m \cdot s / rad],$$

$$\mu_x = 15000[N \cdot m / s], \quad \mu_y = 15000[N \cdot m / s], \quad T_D = 0.0072[s], \quad \omega_0 = 314[s^{-1}].$$

Initial conditions

$$x_I(0) = 0; \quad y_I(0) = 0; \quad \phi_I(0) = 0; \quad \phi_2(0) = 0; \quad \phi_3(0) = 0; \quad M(0) = 0;$$

$$\dot{x}_I(0) = 0; \quad \dot{y}_I(0) = 0; \quad \dot{\phi}_I(0) = 0; \quad \dot{\phi}_2(0) = 0; \quad \dot{\phi}_3(0) = 0; \quad \dot{M}(0) = 0.$$
(3.1)

We solve the autonomous system of differential equations of motion of oscillating masses by the Rosenbrock numerical method with help of Maple13 software. For the transient mode of the machine, it is enough to limit the time to two seconds. The results of modeling by generalized coordinates are shown in Fig.4.

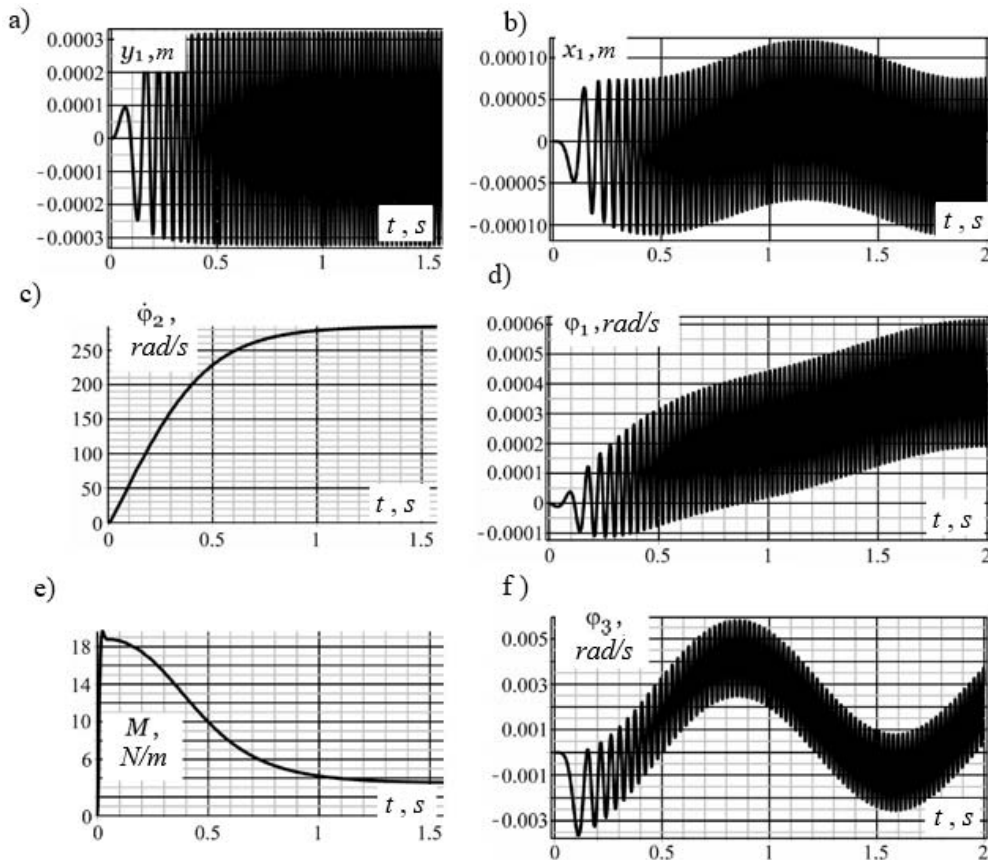

Fig.4. Time dependencies of the motion of oscillating masses by generalized coordinates.

The obtained dependencies indicate that the vibrating machine goes to steady state (electric motor – at rated speed) for about 1.7 [s] (Figs 4c, e). The set oscillation of the working body along the vertical axis is $y_I = 0.32[mm]$ (Fig.4a) at a rotational speed $\Omega = 305[rad/s]$ (2920 [rpm]) (Fig.4c). In this case, the overload on the working body is as follows

$$\xi = \frac{y_l \Omega^2}{g} = \frac{0.00032 \cdot 305^2}{9.81} = 3.$$

The oscillation of the working body along the horizontal axis is $x_l = 0.09$ [mm] (Fig.4b), which is by 3-5 times less than the vertical component. The amplitude of angular oscillations of the working body (Fig.4d) is insignificant and is $\varphi_l = 0.00021$ [rad] = 0.012 [deg].

Except for angular oscillations at forced frequency of $\Omega = 305$ [rad/s], the pendulum oscillates around the axis of the shaft with a period of 1.5 [s]. It reaches nominal speeds without significant dynamic modes.

3.2. The results of experimental studies

The experimental industrial sample of the vibration table is made (Fig.5a) and the signal (Fig.6) from (Fig.5b) rigidly fixed to the working body sensor (weight m_l) was picked up.

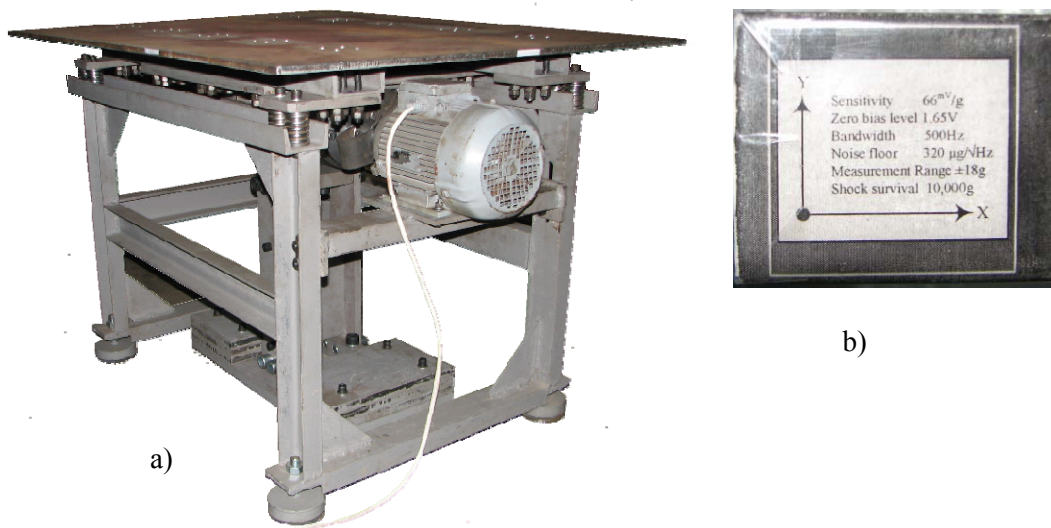

Fig.5. Industrial sample of the vibrating table (a) and sensor (b) connected to the working body to record the time characteristics of the oscillating mass

Assuming that the sensor is calibrated of $U'_{k1g} = 66$ [mV/g] (Fig.5b), and the amplitude value of the sensor is $U_l = (1.9 - 1.4) / 2 = 0.25$ [V] (Fig.6a), the ξ conversion factor, which is also an indicator of overload, is calculated as

$$\xi = U_l / U'_{k1g} = 0.25 / 0.066 = 3.8.$$

The operation of the vibrating table with the loading of the working body with a steel disk of 130 kg mass, laid through a thick soft rubber pad, has been studied. This simulated the actual load, as the rubber has high dissipative properties and ensures a higher proportion of mass attachment. The amplitude of oscillations of the working body (Fig.6b) has not changed.

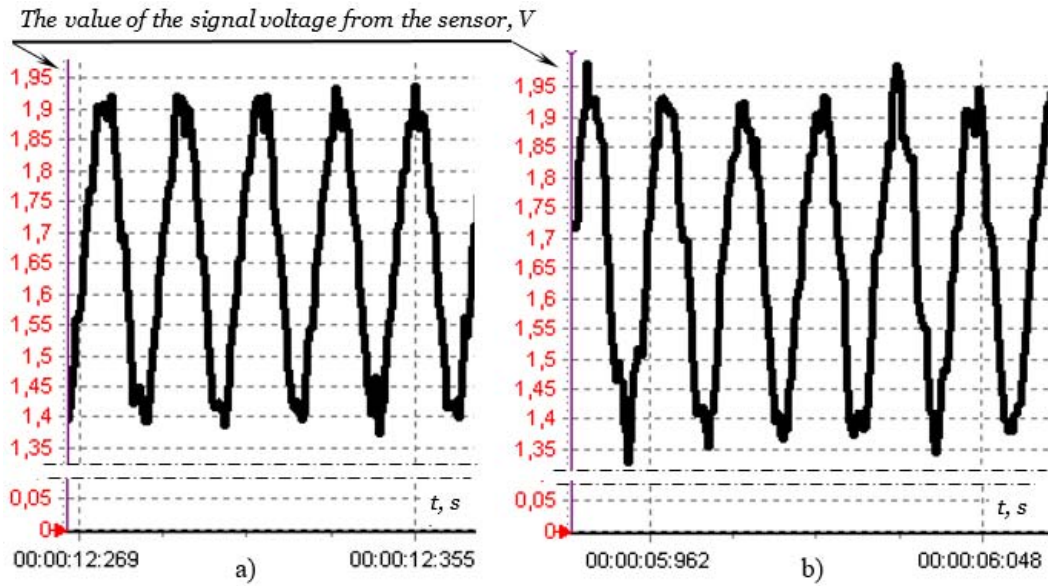

Fig.6. Experimental time characteristics of the movement of the working body without (a) and with (b) loading mass of $m_{load} = 130$ [kg].

Compared with unbalanced machines, this design is characterized by instantaneous start and stop of the drive without prolonged transient modes (Fig.7). The system practically does not react to the resonant peak caused by vibration-insulating elastic elements.

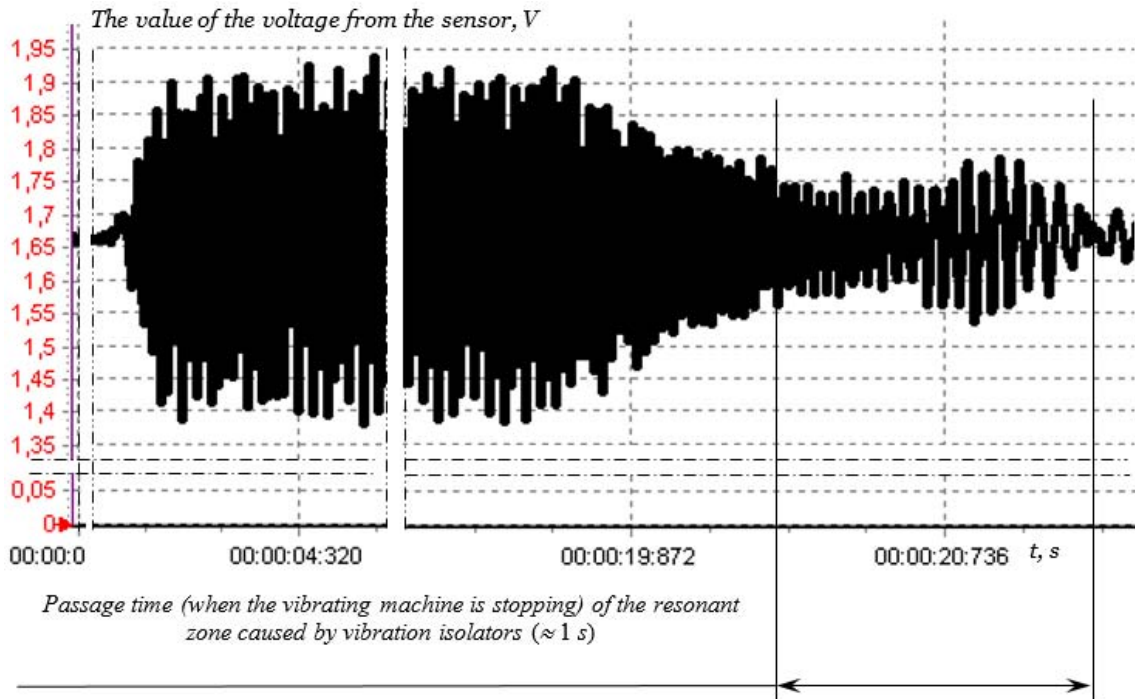

Fig.7. Experimental time characteristics of the working body movement when starting and stopping the vibrating table.

Conclusions

Two-mass vibration systems with eccentric-pendulum drive are widely used in industrial production and in mechanical engineering. The above resonance mode of the oscillating system and the structural solution of the working body ensures high rigidity of the structure at a relatively low weight. The first natural frequency of the working body exceeds four times the forced oscillation frequency of the system. Therefore, the parasitic oscillations of the working body, as a body with distributed mass, are minimal at the frequency of forced oscillations.

On the basis of Lagrange equations of the second kind, the system of differential equations ensures modeling of the energies of the oscillatory system without simplifications and conditional assumptions, including energy dissipation. For the adopted parameters, the simulation results showed that the oscillations of the working body along the horizontal axis are 3-5 times less than the vertical component. The amplitude of angular oscillations of the working body is insignificant and is 0.012 degrees. At nominal operating modes such an oscillating system is based on small dynamic modes.

The proposed two-mass vibration system with eccentric-pendulum drive in above resonant oscillation mode is characterized by instantaneous start and stop of the drive without prolonged transient modes. The system does not react to the resonant peak caused by vibration-insulating elastic elements. Experimental tests have shown the advantage of the developed vibration system in comparison with unbalanced ones.

Nomenclature

- c_x, c_y – stiffness coefficients by the x and y axes, respectively, [N/m]
 F_0 – excitation force, [N]
 H_{12}, H_{23}, H_{13} – linear dimensions, [m], Fig.1
 J_1, J_2, J_3 – moments of inertia of m_1, m_2 and m_3 masses respectively, [$kg \cdot m^2$]
 M – moment of perturbation of the rotor of the electric motor, [$N \cdot m$]
 M_{max} – maximum torque of the electric motor, [$N \cdot m$]
 m_1, m_2, m_3 – respectively, the mass of the working body, the eccentric shaft and the pendulum, [kg]
 T_D – electromagnetic time constant, [s]
 x, y, z – coordinate axes
 x_1, y_1 – linear coordinates of the center of m_1 mass, [m]
 x_2, y_2, x_3, y_3 – linear coordinates of centers of m_2 and m_3 mass respectively, [m]
 ε – eccentricity, [m]
 ν_e – forced frequency of the working body, [Hz]
 μ_x, μ_y – proportional to the velocity viscous friction coefficients reflect the energy dissipation in the vibration isolators as the masses of m_1 move along the x and y axes respectively, [$N \cdot s/m$]
 $\hat{\mu}_2, \hat{\mu}_3$ – coefficients of the viscous rolling resistance of the bearings of the m_1 and m_3 masses, [$N \cdot m \cdot s/rad$]
 φ_1 – angular deviation of m_1 mass from its own center of mass, [$^\circ$]
 φ_2, φ_3 – angular deviation of m_2 and m_3 masses around their own centers of mass, respectively, [$^\circ$]
 ω_0 – circular voltage frequency in the power grid, [s^{-1}]
 Ω – rotational speed (the forced frequency), [rad/s]

References

- [1] Bednarski Ł. and Michalczyk J. (2017): *Modelling of the working process of vibratory conveyors applied in the metallurgical industry.* – Archives of Metallurgy and Materials, vol.62, No.2, pp.721-728.
- [2] Filimonikhin G. and Yatsun V. (2017): *Conditions of replacing a single frequency vibro-exciter with a dual-frequency one in the form of passive auto-balancer.* – Naukovyi Visnyk Natsionalnoho Hirnychoho Universytetu, vol.1, pp.61-68.
- [3] Nadutyi V.P., Sukharyov V.V. and Belyushyn D.V. (2013): *Determination of stress condition of vibrating feeder for ore drawing from the block under impact loads.* – Metallurgical & Mining Industry, vol.51, pp.24-26.
- [4] Babitsky V. (2013): *Theory of vibro-impact systems and applications.* – Springer Science & Business Media.
- [5] Luo G., Zhang Y., Xie J. and Zhang J. (2007): *Vibro-impact dynamics near a strong resonance point.* – Acta Mechanica Sinica, vol.23, No.3, pp.329-341.

- [6] Sokolov I.J., Babitsky V.I. and Halliwell N.A. (2007): *Autoresonant vibro-impact system with electromagnetic excitation*. – Journal of Sound and Vibration, vol.308, pp.375-391.
- [7] Rajesh K. and Saheb K.M. (2018): *Large amplitude free vibration analysis of tapered Timoshenko beams using coupled displacement field method*. – Int. Journal of Applied Mechanics and Engineering, vol.23, No.3, pp.673-688. DOI: 10.2478/ijame-2018-0037
- [8] Gharaibeh M.A., Obeidat A.M. and Obaidat M.H. (2018): *Numerical investigation of the free vibration of partially clamped rectangular plates*. – Int. Journal of Applied Mechanics and Engineering, vol.23, No.2, pp.385-400. DOI: 10.2478/ijame-2018-0022
- [9] Joubaneh Eshagh F., Barry Oumar R. and Tanbour Hesham E. (2018): *Analytical and experimental vibration of sandwich beams having various boundary conditions*. – Journal of Sound and Vibration, vol.18. doi.org/10.1155/2018/3682370
- [10] Xianjie Shi and Dongyan Shi (2018): *Free and forced vibration analysis of T-shaped plates with general elastic boundary supports*. – Journal of Low Frequency Noise, Vibration and Active Control, vol.37, No.2, pp.355-372. DOI: 10.1177/1461348418756021
- [11] Mirzabeigy A. and Madoliat R. (2018): *Free vibration analysis of a conservative two-mass system with general odd type nonlinear connection*. – Proc. Natl. Acad. Sci., India, Sect. A Phys. Sci., vol.88, pp.145-156. <https://doi.org/10.1007/s40010-017-0372>
- [12] Panovko G. and Shokhin A. (2018): *Experimental analysis of the oscillations of two-mass system with self-synchronizing unbalance vibration exciters*. – Journal Vibroengineering PROCEDIA, vol.18, pp.8-13. doi.org/10.21595/vp.2018.19906
- [13] Jia-Jang Wu (2006): *Free vibration characteristics of a rectangular plate carrying multiple three-degree-of-freedom spring-mass systems using equivalent mass method*. – International Journal of Solids and Structures, vol.43, No.3-4, pp.727-746. doi.org/10.1016/j.ijsolstr.2005.03.061
- [14] Vera S.A., Febbo M., Mendez C.G. and Paz R. (2005): *Vibrations of a plate with an attached two degree of freedom system*. – Journal of Sound and Vibration, vol.285, No.1, pp.457-466. DOI: 10.1016/j.jsv.2004.09.020
- [15] Gursky V. and Kuzio I. (2018): *Dynamic analysis of a rod vibro-impact system with intermediate supports*. – Acta Mechanica et Automatica, vol.12, No.2, pp.127-134. DOI 10.2478/ama-2018-0020
- [16] Gorman D.J. (1995): *Free vibration of orthotropic cantilever plates with point supports*. – Journal of Engineering Mechanics, vol.121, No.8, pp.851-857.
- [17] Gorman D.J. (1999): *Accurate free vibration analysis of point supported Mindlin plates by the superposition method*. – Journal of Sound and Vibration, vol.219, No.2, pp.265-277.
- [18] Gorman D.J. and Singal R.K. (1991): *Analytical and experimental study of vibrating rectangular plates on rigid point supports*. – AIAA Journal, vol.29, No.5, pp.838-844.
- [19] Gorman D.J. (1992): *A general analytical solution for free vibration of rectangular plates resting on fixed supports and with attached masses*. – Journal of Electronic Packaging, vol.114, 239.
- [20] Gorman D.J. (1999): *Vibration analysis of plates by the superposition method*. – Vol.3, World Scientific.
- [21] Abrahams I.D. and Davis A.M.J. (2002): *Deflection of a partially clamped elastic plate*. – In IUTAM Symposium on Diffraction and Scattering in Fluid Mechanics and Elasticity (pp.303-312). Springer Netherlands.
- [22] Abrahams I.D., Davis A.M. and Smith S.G.L. (2008): *Matrix Wiener-Hopf approximation for a partially clamped plate*. – Quarterly Journal of Mechanics and Applied Mathematics, vol.61, No.2.
- [23] Shatokhin V.M. (2008): *Analysis and parametric synthesis of non-linear power transmission of machines: monograph*. – Kharkiv: NU «KhPI», 456 p.

Received: May, 14, 2020

Revised: July 8, 2020