



---

## ELECTRIC VEHICLE CHARGING – ASPECTS OF POWER QUALITY AND ELECTROMAGNETIC COMPATIBILITY

Aleksander Chudy, M.Sc., Eng.<sup>1\*</sup>, prof. dr hab. Henryka Danuta Stryczewska, Eng.<sup>2</sup>

<sup>1</sup>Lublin University of Technology - Department of Electrical Engineering and Electrotechnologies, e-mail: a.chudy@pollub.pl

<sup>2</sup>Lublin University of Technology - Department of Electrical Engineering and Electrotechnologies, e-mail: h.stryczewska@pollub.pl

\* Corresponding author

---

**Abstract** – Electromobility is becoming an increasingly popular topic mostly thanks to its positive environmental impact. Replacing combustion engine cars with electric vehicles seems to be a matter of time. Electric cars have many advantages, but their impact on a power quality must be taken into consideration. The article describes current status of electromobility and problems related to the influence of charging stations on a power system. The issue of standardisation of electromagnetic compatibility requirements for charging stations is also discussed.

**Key words** – electromagnetic compatibility, electric vehicle, charging stations, standardisation

---

### INTRODUCTION

These days, internal combustion engine vehicles (ICEVs) are considered to be one of the major contributors to increasingly serious environmental problems due to the fact that they emit greenhouse gases (GHG). The transportation sector is said to be liable for 26% of global CO<sub>2</sub> emissions. This proportion is even higher in some countries (at or above 30%), for instance the transportation sector in Israel accounts for 39% of GHG emissions [1]. Various scientific, political and industrial communities are participating in efforts to reduce GHG emissions, escape fossil fuels scarcity and their price volatility. For these reasons, electric vehicles (EVs) have again become a very interesting alternative in recent years. Renewed interest in EVs has contributed to the creation of the new term electromobility (also known as e-mobility), which according to [2] means the electrification of individual transport. It can also be defined as a road transport system based on electrically powered vehicles as well [3].

The development of lithium-ion batteries plays a significant role in a successful commercialisation of EVs, as well. Improvements in energy storage methods, especially the drop of lithium-ion batteries prices and the increase in the device's specific energy, lead to another opportunity, maybe the greatest, to implement EVs [4].

From the perspective of an electrical grid, EVs are viewed as new consumers. They contribute to higher energy

demand and the need to increase power generation. The EV charging process is able to influence the behaviour of the power system because of its unprecedented level of complexity. Due to EVs' possible negative impact on the grid's power quality assessment has become very important topic [4]. Distribution networks, particularly residential ones, are considered to be the weakest part of the power system in terms of the impact of EV charging on power quality issues [5]. The introduction of electromobility is a challenge for all sectors of the industry.

This paper provides information about the current status of electromobility and describes power quality problems connected with EV charging. Electromagnetic compatibility (EMC) standards concerning chargers are also characterized. Furthermore, an overview of papers related to EV charging and EMC testing is presented.

In this paper, the term electric vehicle applies only to cars equipped with an electric motor that are fully or partially powered by electricity.

### I. CURRENT STATUS OF ELECTROMOBILITY

According to [6] the global number of electric cars reached 5.1 million (2.3 million units in China, 1.3 million in Europe and 1.1 million in the United States of America) in 2018. As of the middle of October 2019, there were 6672 electric vehicles in Poland (4178 battery electric vehicles, BEV, and 2494 plug-in hybrid electric vehicles, PHEV) [7].

As the number of vehicles increases, the publicly

accessible infrastructure is also developing. There were 888 electric vehicle charging stations in Poland in the middle of October 2019. 624 were slow AC charging stations with 22 kW power or less, and 264 fast DC charging stations [7]. Based on [6] there were 538 609 publicly accessible chargers (395 107 slow and 143 502 fast) in the world in 2018. It can be concluded that 105 361 new chargers were introduced in that year when compared with a total number of EV chargers in 2017 (433 248). As the figures show, the field of electromobility in Poland is rather minimal, however it is growing fast. Various organisations announced introducing new charging stations in Poland in the upcoming years [7]. Table 1. shows countries with the highest number publicly accessible slow and fast chargers in 2018.

**Table 1.** Countries with the highest number publicly accessible slow and fast chargers in 2018 [6]

Country	Number of chargers
China	275 000
The United States	54 500
Netherlands	36 671
Japan	29 971
Germany	25 724
France	24 132
United Kingdom	17 424

The Polish e-mobility index [7], that is being updated by the Polish Automotive Industry Association (PZPM) and The Polish Alternative Fuels Association (PSPA), is available on the PZPM's website. Anyone interested can find out how many electric vehicles travel on Polish roads and how many charging stations are in operation. All data was collected by PZPM and PSPA on the basis of complex data analyses originating from the Central Register of Vehicles, as well as their own research and records kept [8].

## II. AN ELECTRICAL NETWORK AND THE USE OF ELECTRIC VEHICLES: POWER QUALITY ASPECTS

The main cause of power quality problems in power systems are non-linear loads. Low power quality in electrical systems might cause [9]:

- protection malfunction,
- transformer saturation,
- motor overheating,
- damage of a generator and turbine shafts,
- system resonance,
- capacitor overloading,
- light intensity change, which may result in irritation and headaches.

Electric vehicles must be treated as new demanding consumers. The high power required by fast charging stations (at least 50 kW or even 350 kW in ultrafast charging stations) might result in many negative effects on an electrical grid in the form of voltage and/or frequency fluctuations, increased transmission losses, harmonics, phase unbalance, high frequency conducted and radiated disturbances and other power quality problems. Taking into account characteristic properties of EVs' electrical equipment, EV chargers and the possibility of the occurrence of large current and voltage pulses, wire bundles and a large number of connections, it can be concluded that there is a

considerable potential for mutual disruption of the work of individual electronic components and modules triggered by electrical conduction or the existence of capacitive and inductive couplings or due to radiated emissions. Fig. 1. shows a classification of EVs' impact on the power system [4, 9-11].

Depending on the number of EVs, network characteristics and charging capabilities of EVs, effects on the power quality can be significant or negligible. As a consequence of the volatile nature of EV charging, problems of increased peak demand and decreased lifetime of a transformer might also arise [12]. For these reasons ongoing research into the topic of charging strategies is popular [13-16].

Since most of the charging will take place in private areas, low voltage supply systems will mostly be impacted by EV adoption. Currently the low number of electric vehicles across Europe does not pose a significant threat to the distribution grids. However, the EV share will be rising in the upcoming years and the power quality parameters may be affected, for instance due to an old existing power system infrastructure. This can impose severe limitations on the realisation of an appropriate placement of EV charging stations and on the choice of EV charging technologies because there were no EVs when the road and grid infrastructure was established and constructed [17-19].

The presence of a high harmonic current injection in the distribution networks is significant. EV chargers contain non-linear power electronic devices, for instance AC/DC converters. Due to this fact, the endurance and performance of distribution network equipment might be affected (additional losses in cables and windings of the power transformers) [12]. EV charging must meet harmonics and voltage requirements as specified by EN 50160, IEC 61000-3-2/3-12 and IEEE 519 standards.

On the other hand, bidirectional charging of EVs and the implementation of Vehicle to Grid (V2G) technology can contribute to an improvement of the power quality parameters as well. This solution offers many benefits to the power system due to the possibility of using energy stored in electric vehicles' batteries, for instance as a spinning reserve to meet sudden power demand changes. EVs can also be used for frequency regulation, load balancing, voltage regulation, harmonic reduction, and reactive power compensation. Worth mentioning is a fact that in this configuration the EV must be almost constantly connected to the grid to be a part of an auxiliary service market. Public parking lots with many charging points (shopping malls, hospitals, workplaces, universities, city centres) would seem to be the best solution for this strategy. EVs could also improve operation of a power system in terms of reliability and demand and help in case of outages in the power system. Since renewable energy resources often mismatch electricity demand, the usage of electric vehicles as a storage technique can also increase the integration level of these resources [9, 20].

Other power conditioning solutions can be as follows:

- device level: the implementation of new topologies of chargers (for instance chargers equipped with front-end and back end converters) and modifications in the control

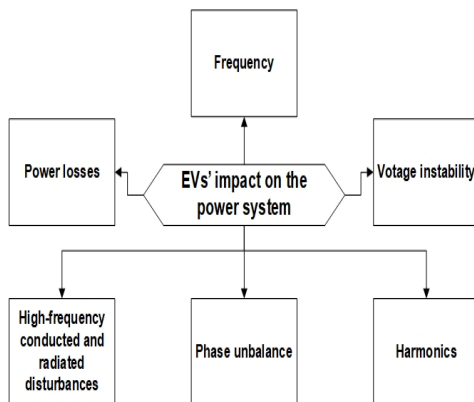

Fig. 1. Electromobility's impact on the power system, based on: [4, 9 11]

systems of chargers (current control instead of voltage control),

- power system level: the use of active filters or passive power filters that contribute to harmonics cancelation (power system level).

The implementation of electromobility should be connected with analysing viewpoints of several parties: an owner of an EV, an aggregator, a parking lot owner, a transmission system operator (TSO), and a distribution system operator (DSO) to maintain an acceptable level of power quality [21].

### III. ELECTROMAGNETIC COMPATIBILITY STANDARDS FOR EV CHARGING

Electromagnetic compatibility (EMC) is the ability of a given device or a system to work properly in a specific electromagnetic environment. A given device should not emit electromagnetic field disturbances and should not interfere with the proper operation of other devices [22].

The main international standards regarding electromagnetic compatibility are IEC (International Electrotechnical Commission) and CISPR (International Special Committee on Radio Interference) standards. The latter are used as national standards in various countries and are also considered global standards. IEC and CISPR standards are usually revised every 5 years to adapt their technology level to current conditions. Harmonised European standards have been introduced with the European Union's EMC directive 2014/30/EU which guarantees electrical and electronic equipment does not produce electromagnetic interference nor is affected by it. The standards specify measurement methods and limits as well as testing levels for both emissions and resistance of electrical equipment, installations and systems. If the target of the manufacturers of EV chargers is the European Union, they need to adhere to the previously mentioned EMC directive and make a Declaration of Conformity. Regulations similar to these exist in most territories for most product types [23, 24].

EMC standards are intended to protect electrical or electronic devices against various interferences (for instance

surges or electrostatic discharges) and damage by minimizing the risk factors in their environment. Compliance with EMC standards is compulsory in most markets. EMC monitoring is important to comply with legal requirements, increase quality of a product and reduce the risk of non-compliance [23]. The evaluation of EMC standards requirements for EV chargers consists of emissions, susceptibility and immunity tests. EMC testing also ensures that when an EV is plugged to an electrical grid, an unexpected vehicle motion or other, incorrect charging conditions would not happen.

IEC standards that define the EMC requirements for performance between plug-in EV chargers and EVs are as follows [25]:

- IEC 61851-21-1, which informs about general test conditions, for instance nominal voltage range and an EV's condition during testing. It specifies test methods and requirements on immunity and emission as well,
- IEC 61851-21-2, which specifies requirements on immunity and emission for off board components or equipment of EV charging systems with rated input and output voltage up to 1000 V AC or 1500 V DC. The current version of this standard takes into account EMC pre-compliance test methods for either the charging system or the vehicle alone, but not their combined setup.

EMC requirements that refers to performance between charging station and grid are [26]:

- IEC 61000-6-2,
- IEC 61000-6-3:2006 + AMD1:2010 CSV,
- IEC 61000-3-12.

Immunity and disturbance requirements including load and operating conditions as well as disturbance limits for wireless power transfer (WPT) are covered in IEC 61980-1:2015. The second edition of this standard is planned to be released in 2020. What is more, IEC TS 61980-3:2019 contains specific EMC requirements for magnetic field WPT systems. It refers to CISPR 11 emission requirements [27, 28].

Another paper of great importance is Regulation No 10 of the Economic Commission for Europe of the United Nations [26], which provide grounds for the approval of specific types of vehicles for production and operation (homologation). It describes EMC emissions limits, immunity levels, test equipment and procedures that are being carried out in an open area test sites (OATS) and anechoic chambers, for instance, absorber lined shielded enclosures (ALSE). [29] refers to CISPR requirements.

To the knowledge of the authors, EMC testing process of EV chargers is not covered well in the literature. There are only few publications that cover this topic. Worth mentioning is a paper written by Pliakostathis et al. [25]. EMC performance of three high-power-charging columns according to IEC 61851 21 2:2016 standard has been analysed. The research has been carried out inside VeLA 9 validated EMC semi anechoic chamber (SAC) at the Joint Research Centre of the European Commission. Fig. 2. and Fig. 3. show laboratory and instrument setup for the conducted and radiated emissions testing respectively.

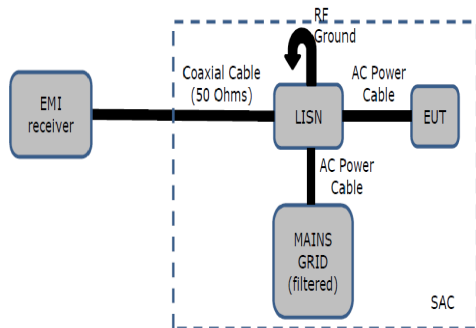

Fig. 2. Vela 9 instrument and laboratory setup for the conducted emissions testing, EUT Equipment Under Test, LISN – Line Impedance Stabilization Network, RF Ground - Reference Ground, EMI – Electromagnetic Interference [25]

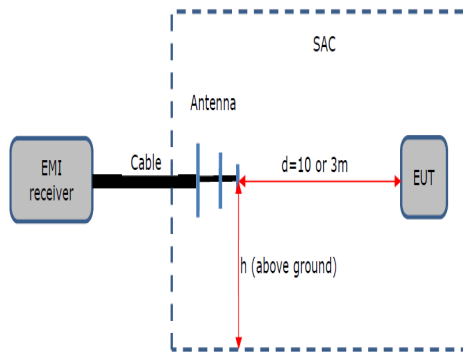

Fig. 3. Vela 9 instrument and laboratory setup for the radiated emissions testing [25]

Results of conductive and radiated emissions measurements on prototypical and series electric vehicles (EV) under charge have been presented in [30]. Furthermore, in [31] Zhong Zheng and Daifang Zhang studied the EMC problems of the DC charging pile system.

Electromagnetic interferences ranging from 150 KHz to 30 MHz on the AC power lines could be captured with Line Impedance Stabilisation Network, which is in accordance with IEC 61851-21-2 requirements. Fig. 4. shows exemplary results of the conducted emission test of BMW i3 during mode 2 charging at 8.4 A.

Electromagnetic compatibility issues and solutions for WPT for EVs seem to be the trend as this technology is at the research and development stage. A comprehensive review of WPT for EVs can be found in [32].

#### IV. CONCLUSIONS

As electromobility is a new developing market, a great deal of standardisation is taking place. New standards concerning EVs and EV charging will be released in the upcoming years. Plug-in charging is the better standardized,

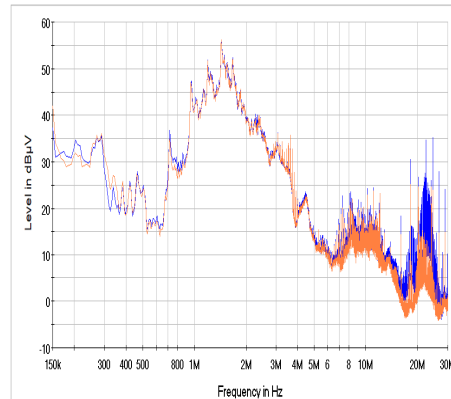

Line-N detector AVERAGE Line-L1 detector AVERAGE

Fig. 4. Results of the conducted emission test of BMW i3 during mode 2 charging at 8.4 A

more developed and naturally much more popular method of EV charging. There is still a lack of accurate, complete and comprehensive requirements for wireless charging, however the topic is getting popular among researchers.

Policymakers aiming to promote GHG reduction should pay particular attention to EVs, especially plug-in ones, because they do not emit harmful tailpipe pollutants.

Changes in the electrical power systems (for instance, the integration of EVs with a grid) have a significant impact on the operation and design of these system. The topic of the impact of EV chargers on the power system ought to be crucial especially for distribution systems operators as distribution is the weakest part of the power system in terms of EV charging. Integration of renewable energy resources and EV chargers, which are equipped with power electronic equipment should also be taken into consideration.

At the moment, the growth of harmonic distortions from home appliances is faster than from electric vehicles due to their slower adoption rate, however it might change in the near future as a result of increased interest in electromobility and the development of sustainable energy policies.

The success of electromobility implementation depends on various aspects:

- improvements of energy storage systems and lower costs of lithium-ion batteries,
- mitigation of power quality issues, especially in the fast EV charger sector (especially advancements in topologies of converters and inverters),
- cooperation of industry, research laboratories and governments to create new standards and technologies,
- favourable policies and more incentives for EV consumers
- more GHG control policies.

Electromagnetic compatibility issues concerning EV charging stations are getting more and more attention as a result of the complexity of these systems. One of the major drawbacks of EMC testing is that one type of compliance activity does not fit all territories. The importance of EMC

testing and power quality issues will definitely grow in the near future due to the fact that the implications of the mass release and large-scale deployment of high-power chargers for electric vehicles on the market are still unknown from the electromagnetic interference point of view. As the charging technology becomes more mature, new currently unknown problems related to previously mentioned topics might arise. Therefore, there is a strong need for more research, tests and simulations in the fields of the impact of EV charging on power quality parameters and electromagnetic compatibility.

#### ŁADOWANIE SAMOCHODÓW ELEKTRYCZNYCH - ASPEKTY JAKOŚCI ENERGII ELEKTRYCZNEJ I KOMPATYBILNOŚĆ ELEKTROMAGNETYCZNEJ

Elektromobilność staje się coraz popularniejszym tematem, między innymi ze względu na jej pozytywny wpływ na środowisko. Zastąpienie samochodów z silnikami spalinowymi samochodami elektrycznymi wydaje się być kwestią czasu. Samochody elektryczne posiadają wiele zalet, niemniej jednak należy wziąć pod uwagę ich wpływ na jakość dostarczanej energii. W artykule opisano obecny stan elektromobilności oraz problemy związane z wpływem stacji ładowania na system elektroenergetyczny. Poruszono również kwestię standaryzacji wymagań kompatybilności elektromagnetycznej odnoszących się do stacji ładowania.

**Słowa kluczowe:** kompatybilność elektromagnetyczna, samochody elektryczne, stacje ładowania, standaryzacja

#### BIBLIOGRAPHY

- [1] Kissinger, M.; Reznik, A. Detailed urban analysis of commute-related GHG emissions to guide urban mitigation measures. *Environmental Impact Assessment Review* (online). DOI: 10.1016/j.eiar.2019.01.003, 2019.
- [2] van Mierlo, J. *The World Electric Vehicle Journal, The Open Access Journal for the e-Mobility Scene. WEVJ* (online). DOI: 10.3390/wevj9010001, 2018.
- [3] Grauers A.; Sarasini S.; Karlström M. *System Perspectives on Electromobility 2017: Why electromobility and what is it?*; Chalmers University of Technology: Göteborg, Sweden, 2017.
- [4] Tiano, F. A.; Rizzo, G.; Marra, D. *Design and Optimization of a Charging Station for Electric Vehicles based on Compressed Air Energy Storage. IFAC-PapersOnLine* (online). DOI: 10.1016/j.ifacol.2018.07.038, 2018.
- [5] Lucas, A.; Bonavitaola, F.; Kotsakis, E.; Fulli, G. *Grid harmonic impact of multiple electric vehicle fast charging. Electric Power Systems Research* (online). DOI: 10.1016/j.epsr.2015.05.012, 2015.
- [6] *Global EV Outlook 2019*; OECD, 2019.
- [7] PSPA - Polskie Stowarzyszenie Paliw Alternatywnych, 2019. <http://pspa.com.pl/> (accessed October 11, 2019).
- [8] *Licznik elektromobilności: w lipcu br. 6,3 tys. samochodów elektrycznych w Polsce - ORPA.PL* (Obserwatorium Rynku Paliw Alternatywnych), 2019. <https://www.orpa.pl/licznik-elektromobilnosci-w-lipcu-br-63-tys-samochodow-elektrycznych-w-polsce/> (accessed October 11, 2019).
- [9] Ahmadi, A.; Tavakoli, A.; Jamborsalamati, P.; Rezaei, N.; Miveh, M. R.; Gandoman, F. H.; Heidari, A.; Nezhad, A. E. *Power quality improvement in smart grids using electric vehicles: a review. IET Electrical Systems in Transportation* (online). DOI: 10.1049/iet-est.2018.5023, 2019.
- [10] IEC 61851-21-1. *Electric vehicle conductive charging system - Part 21-1 Electric vehicle on-board charger EMC requirements for conductive connection to AC/DC supply*, 2017.
- [11] Burliński, R.; Łukjanow, S. *Metody analizy i oceny promieniowania elektromagnetycznego w badaniach kompatybilności elektromagnetycznej (EMC) pojazdów samochodowych zwłaszcza elektrycznych. The Archives of Automotive Engineering – Archiwum Motoryzacji* (online). DOI: 10.14669/AM.VOL80.ART6, 2018.
- [12] Khan, W.; Ahmad, A.; Ahmad, F.; Saad Alam, M. *A Comprehensive Review of Fast Charging Infrastructure for Electric Vehicles. Smart Science* (online). DOI: 10.1080/23080477.2018.1437323, 2018.
- [13] Colmenar-Santos, A.; Muñoz-Gómez, A.-M.; Rosales-Asensio, E.; López-Rey, Á. *Electric vehicle charging strategy to support renewable energy sources in Europe 2050 low-carbon scenario. Energy* (online). DOI: 10.1016/j.energy.2019.06.118, 2019.
- [14] Xu, S.; Yan, Z.; Feng, D.; Zhao, X. *Decentralized charging control strategy of the electric vehicle aggregator based on augmented Lagrangian method. International Journal of Electrical Power & Energy Systems* (online). DOI: 10.1016/j.ijepes.2018.07.024, 2019.
- [15] Ji, D.; Chen, L.; Ma, T.; Wang, J.; Liu, S.; Ma, X.; Wang, F. *Research on adaptability of charging strategy for electric vehicle power battery. Journal of Power Sources* (online). DOI: 10.1016/j.jpowsour.2019.226911, 2019.
- [16] Bandpey, M. F.; Firouzjahi, K. G. *Two-stage charging strategy of plug-in electric vehicles based on fuzzy control. Computers & Operations Research* (online). DOI: 10.1016/j.cor.2017.07.014, 2018.
- [17] Deb, S.; Tammi, K.; Kalita, K.; Mahanta, P. *Review of recent trends in charging infrastructure planning for electric vehicles. WIREs Energy Environ* (online). DOI: 10.1002/wene.306, 2018.
- [18] Harighi, T.; Bayindir, R.; Padmanaban, S.; Mihet-Popa, L.; Hossain, E. *An Overview of Energy Scenarios, Storage Systems and the Infrastructure for Vehicle-to-Grid Technology. Energies* (online). DOI: 10.3390/en11082174, 2018.
- [19] Wargers, A.; Kula, J.; Ortiz De Obregon, F.; Rubio, D. *European Distribution System Operators for Smart Grids: Smart charging: integrating a large widespread of electric cars in electricity distribution grids*, 2018.
- [20] Liu, G.; Kang, L.; Luan, Z.; Qiu, J.; Zheng, F. *Charging Station and Power Network Planning for Integrated Electric Vehicles (EVs). Energies* (online). DOI: 10.3390/en12132595, 2019.
- [21] Marra, D.; Rizzo, G.; Shafie-khah, M.; Siano, P.; Tiano, F. A. *Vehicle electrification: A further variable toward integrated intelligent energy systems. In: 2017 IEEE International Conference on Environment and Electrical Engineering and 2017 IEEE Industrial and Commercial Power Systems Europe (IEEEIC / I & CPS Europe): Conference proceedings: 6-9 June, 2017, Milan, Italy; IEEE: [Piscataway, New Jersey], 2017; pp. 1-6.*
- [22] Blockx, P.; van den Bossche, P.; Omar, N.; van Mierlo, J.; Rotthier, B.; Cappelle, J. *Beyond the plug and socket: Towards safe standardized charging infrastructures. In: 2013 World Electric Vehicle Symposium and Exhibition (EVS27); IEEE, 2013 - 2013; pp. 1-10.*
- [23] *Kompatybilność elektromagnetyczna, 2015. https://www.eae-elektronik.pl/kompatybilnosc-elektromagnetyczna-i-badania-emc/* (accessed October 16, 2019).
- [24] *Directive 2014/30/EU of the European Parliament and of the Council of 26 February 2014 on the harmonisation of the laws of the Member States relating to electromagnetic compatibility (recast). Applicable from 20 April 2016., 2016.*
- [25] Pliakostathis, K.; Scholz, H.; Trentadue, G.; Zanni, M. *Assessment and analysis of the electromagnetic profile of prototype high-power-charging units for electric vehicles: Contribution to IEC 61851-21-2: radiated and conducted emissions, radiated immunity and exploratory research; Publications Office of the European Union: Luxembourg, 2019.*

- 
- [26] Urban, H. EMC IN EV-CHARGING. <https://impulse.schaffner.com/en/emc-in-ev-charging> (accessed October 18, 2019).
- [27] IEC 61980-1:2015 ED1. Electric vehicle wireless power transfer (WPT) systems - Part 1: General requirements, 2015.
- [28] IEC TS 61980-3:2019. Electric vehicle wireless power transfer (WPT) systems - Part 3: Specific requirements for the magnetic field wireless power transfer systems, 2019.
- [29] Regulation No 10 of the Economic Commission for Europe of the United Nations (UNECE) — Uniform provisions concerning the approval of vehicles with regard to electromagnetic compatibility, 2017.
- [30] Pliakostathis, K.; Scholz, H. On the evaluation of Electromagnetic Compatibility (EMC) of a prototype electric vehicle: Electromagnetic interference filters and EMC remedies to conducted disturbances in AC charging; Publications Office of the European Union: Luxembourg, 2018.
- [31] Zheng, Z.; Zhang, D. Study on Electromagnetic Compatibility of DC Charging Pile. In: 2018 China International Conference on Electricity Distribution (CICED); IEEE, 2018 - 2018; pp. 2805-2810.
- [32] Niu, S.; Xu, H.; Sun, Z.; Shao, Z. Y.; Jian, L. The state-of-the-arts of wireless electric vehicle charging via magnetic resonance: principles, standards and core technologies. *Renewable and Sustainable Energy Reviews* (online). DOI: 10.1016/j.rser.2019.109302, 2019. hmadi, A.; Tavakoli, A.; Jamborsalamati, P.; Rezaei, N.; Miveh, M. R.; Gandoman, F. H.; Heidari, A.; Nezhad, A. E. Power quality improvement in smart grids