

Yoshimi ITO¹

POSITION PAPER - FUNDAMENTAL ISSUES IN SELF-EXCITED CHATTER IN TURNING

Although observing a considerable number of new interesting behavior in dynamic states of machining, nearly all researches into the chatter vibration have been based on those conducted by Tobias, Tlustý and Merritt. In fact, we have established myriad remedies for the chatter suppression on the strength of their achievements; however, some crucial issues remain still in uncertainties, e.g., validity of penetration effects, definition of chatter commencement, influences of directional orientation in stiffness of chuck on stability chart and so on. We must thus scrutinize duly what are the essential features of the chatter vibration. This position paper describes the facing problems of the chatter vibration in detail, aiming at the establishment of a generalized chatter loop. By this chatter loop, we may unveil synthetically the deterioration and improvement of the stability chart by all the influencing attributes, such as forced vibration and non-linearity within the machine-tool-work system.

1. INTRODUCTION

Since the 1930s, the academic research into the chatter vibration in metal cutting and grinding has been actively carried out across the whole world, and in due course we have contrived various remedies to suppress the chatter vibration. As suggested by Arnold of University College of Swansea in the beginning of 1940s, the first academic research is credited to Shizuo Doi of Ryojyun (Lshun) Institute of Technology in the 1930s [1]. After then, many researchers and engineers involved into the related activities, and in the 1960s, as the first stage of the related technology development, Tobias, Tlustý [2] and Merritt contributed to a large extent to establish the theory of the self-excited chatter vibration. In fact, the remedies for chatter suppression advanced amazingly on the basis of their achievements after then. For example, one of such remedies is the “Milling Cutter with Variable Tooth Lead or Pitch“ [3], and at present this milling cutter prevails within the tool industry as a lucrative business.

In retrospect, we used to classify the chatter vibration such as shown in Fig. 1. On the basis of knowledge obtained from our long-standing experience since 1970s, however, we must now modify this classification in consideration of some new findings. In this context, author may suggest the following ideas.

¹ Tokyo Institute of Technology

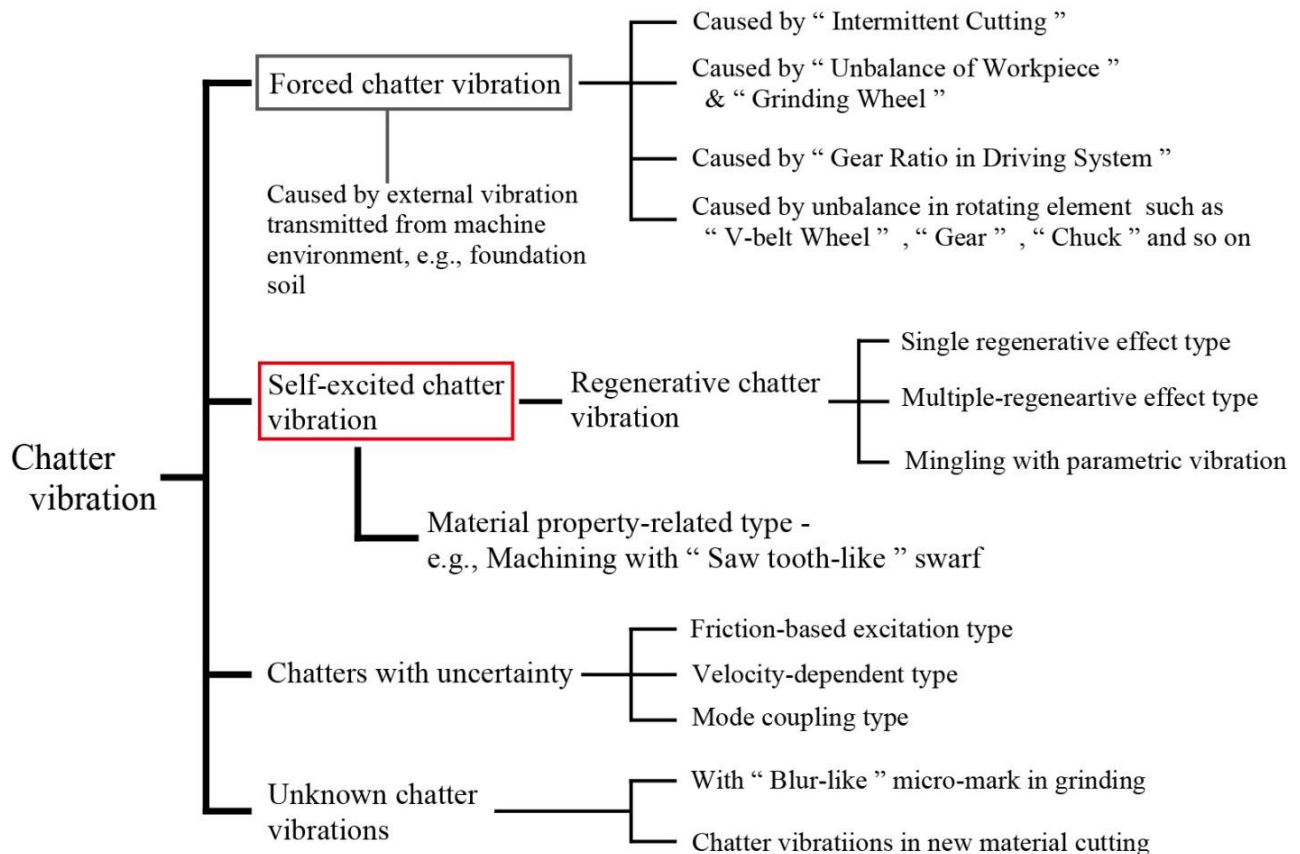

Fig. 1. Classification of chatter vibration in general

- (1) In consideration of remaining uncertainties and ill-defined features in the chatter vibration, it is natural and reasonable to place the stress on the research into the “Self-excited Chatter Vibration”.
- (2) Although the “Forced Chatter Vibration” can, as widely recognized, be suppressed completely by eliminating the forced excitation causalities, we must investigate the unfavorable influence of the forced excitation force, especially that transmitting to the machine through the foundation. It appears that the stability limit of the self-excited chatter may be deteriorated considerably by the simultaneous action of the forced excitation to the machine-tool-work system.
- (3) We must identify the essential feature of the material property-related chatter, i.e., either “Forced Chatter Due to Saw Tooth-like Swarf” or “Self-excited Chatter”.
- (4) Of “Chatters with uncertainties” in Fig. 1, the “Velocity-dependent and Mode Coupling Types” may be regarded as the self-excited chatter. In contrast, there remains something to be seen in the “Friction-based Excitation Type” with higher chatter frequency more than the order of kHz.
- (5) At issue is the “Unknown Chatter Vibrations” in Fig. 1, and we must continue the meticulous observation for the chatter mark and concerns. In fact, we face much more unfavorable chatter vibration, the mark of which is microscopic “Blur-like”, in grinding even now.

Within the self-excited chatter context, it appears that the academic research is not active in the year 2000 and beyond, and that the remedies in practice are stalemate. In many respects, the research has been furthermore carried out on the strength of the old-fashioned knowledge established by Tobias, Tlustý and Merritt. In other words, as widely known, we have not had the new perspectives in the academic research into the essential features of the self-excited chatter since 1970s, although we have various and many new tools in the test rig, experimental techniques, numerical computation method and so on. These suggestions imply the dire necessity for the re-consideration of the self-excited chatter from both the theoretical and experimental aspects aiming at the enhancement of the corresponding technologies.

Thus, this position paper will discuss first the validity of the “Penetration Effect” proposed by Tobias, and then describe the interesting evidences, which may suggest the new horizons in, and could be the clues to unveil the essential features of the self-excited chatter. More specifically, the paper will duly discuss the rational modification of the basic expressions for the self-excited chatter, i.e., “Uncut Chip-thickness Equation”, “Cutting-process Equation” and “Structure Equation”. For example, we must, as will be clear from the case study paper written by Hisayoshi SATO within this Volume, include the “Multiple-regenerative Effect” in the “Uncut Chip-thickness Equation”, and also the non-linearity derived from the structural body component in the “Structure Equation”.

2. FUNDAMENTAL UNDERSTANDING FOR SELF-EXCITED CHATTER THEORIES IN THOSE OF TOBIAS, TLUSTÝ AND MERRITT INCLUDING ISSUES TO BE DISPUTED

Eventually, the research into the self-excited chatter has been, more or less, carried out on the strength of those of Tobias, Tlustý and Merritt so far together with doubtlessly relying on all the achievements already publicized by them. For example, it has been believed that the “Lower-speed Stability” is derived from the “Penetration Effect” proposed by Tobias, although some researchers have changed the due term into the “Process Damping”. In contrast, we have observed a considerable number of evidences, which can suggest the necessities of the re-consideration for those of Tobias, Tlustý and Merritt. Thus, we must discuss again the validity of the hypotheses employed by these earlier researchers. Paraphrasing, we must delve into again the validity of the “Penetration Effect” and also the availability of three basic expressions for the self-excited chatter employed by Tobias and Merritt.

2.1. VALIDITY OF AND FACING ISSUES IN “PENETRATION EFFECT”

In retrospect, Tobias proposed a combination of three basic expressions, i.e., “Dynamic Cutting-process Equation”, “Uncut Chip-thickness Equation with Overlap Factor”, and “Structure Equation”, to analyze the self-excited chatter vibration [4].

Following his proposal, Tlustý and Merritt employed similar expressions, and of these, an interesting as well as a doubtful hypothesis is the “Dynamic Cutting Force“, which was defined as follows.

“The dynamic cutting force is closely related to the cutting speed and cutting processes, and thus can be regarded as the damping force. The dynamic cutting force increases with the decrease of the relief angle of the cutting tool“.

Conceptually, Tobias proposed a generating mechanism for the dynamic cutting force as shown in Fig. 2, and in due course suggested that the dynamic cutting force dP can be written as

$$dP = k_1 ds + k_2 dr + k_3 d\Omega \quad (1)$$

where, $k_1 = (\partial P / \partial s)_{dr=d\Omega=0}$, $k_2 = (\partial P / \partial r)_{ds=d\Omega=0}$, $k_3 = (\partial P / \partial \Omega)_{ds=dr=0}$

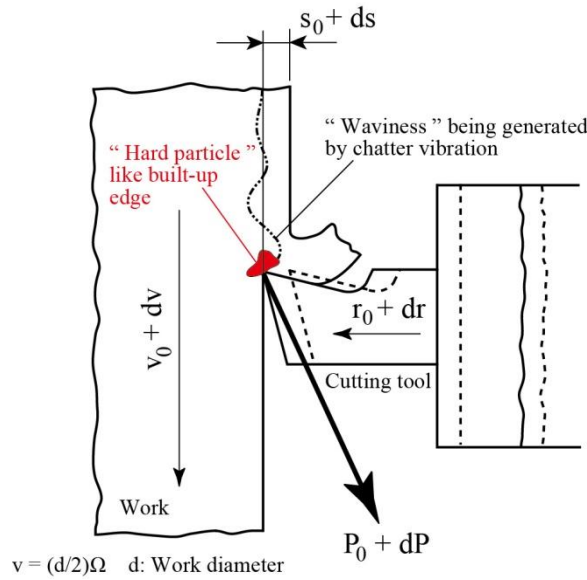

Fig. 2. Mechanism for “Penetration Effect“ proposed by Tobias

In Expression (1), the second and third components correspond directly to the cutting speed, and thus can be regarded as the damping force. Within this context, the “Penetration Effect“ may be caused by the appearance of dr under the dynamic condition. More importantly, the self-excited chatter does not occur when the summation of the damping capacity in the machine-tool-work system and dP is positive.

Tobias stated furthermore the detail of the mechanism as follows.

- (1) In the stable cutting condition with constant feed rate s_0 , and cutting speed v_0 , r_0 can be given by the ordinal conversion, such as $r_0 = s_0 N$ (N =Rotational speed), $N = (1/2)(\Omega/\pi)$.
- (2) If the static cutting force P_0 could change to $P_0 + dP$ by certain triggers, the cutting speed v_0 and feed rate s_0 also change to $v_0 + dv$ and $s_0 + ds$, respectively, simultaneously varying r_0 to $r_0 + dr$.

Importantly, in the dynamic condition, Tobias suggested that s , r and Ω are independent one another. Is this first hypothesis acceptable when considering the feed rate and feed speed in turning, in general, convertible each other?

In short, the variation of the feed rate results from the change of the cutting force, which occurs by certain triggers while turn-top (cylindrical turning), and simultaneously the depth of cut varies. In addition, the more increase of the cutting force, the lower is the cutting speed. These variations are leading factors of the dynamic cutting force. In addition, “dr” was called Rate of Penetration (die Eindringungsgradvariation), and Tobias suggested that dr can facilitate the increase of the lower-speed stability. As mentioned above, dr may increase with the decrease of the relief angle of the cutting tool. Reportedly, Tobias also suggested the difficulty in identifying the dynamic cutting force on that occasion, and moreover proposed that the dynamic cutting force might be calculated by considering some characteristics in the static cutting force, for example, the specific cutting force k_s . As a result, the increment of static cutting force dP_0 can be written as

$$dP_0 = k_s ds_0 + k_\Omega d\Omega \quad (2)$$

Thus,

$$dP = k_1 ds + (k_s - k_1) (2\pi/\Omega) dr + [k_\Omega - (k_s - k_1) (s_0/\Omega)] d\Omega \quad (3)$$

The penetration effect is directly related to the cutting speed, but not the time differentiation of cutting speed. *Is this second hypothesis acceptable?* In Expression (3), furthermore, what is the validity for the effects of $d\Omega$ on the dynamic cutting force? In fact, Tobias demonstrated some calculations of the stability chart by assuming $d\Omega = 0$. As widely known, we can observe $d\Omega$, when the cutting force decreases with cutting speed as called “Drooping Characteristic”. In steel cutting with the common cutting condition, however, the static cutting force is nearly constant with the cutting speed, and thus this assumption appears as to be acceptable.

Summarizing, we must discuss now the essential features of the dynamic cutting force proposed by Tobias, especially considering that of Langhammer [5]. Importantly, Tobias did not measure the dynamic cutting force in accordance with the definition as per Expression (1), because the corresponding test rig was not available on that occasion. In contrast, Langhammer measured later the dynamic cutting force by using the dynamometer of piezo-electric type. He also defined the static, fluctuation and dynamic components in the cutting force as shown in Fig. 3, and demonstrated some interesting results such as shown in Fig. 4. As can be seen from Fig. 4, the dynamic component in the cutting force shows the typical “Drooping Characteristics” in steel cutting.

More specifically, another facing issue is whether the dynamic cutting force proposed by Tobias is identical to that of Langhammer, and thus we must, at least, conduct the following researches.

- (1) Comparison between the dynamic components in stable cutting with that in self-excited chatter to unveil the essential feature of the penetration effect.
- (2) Measurement of the dynamic plowing force in both the stable and self-excited chatter, which can be regarded as an evaluation factor of the penetration effect when verifying the hypothesis suggested by Tobias. The plowing force can be obtained by applying the extrapolation method to the “Cutting Force – Feed rate or Depth of Cut” chart. The force corresponding to the nil in depth of cut or feed rate axis is the plowing force. For

example, from Fig. 4, we can obtain the static plowing force as to be 70 kgf in the case of the principal component of 300 kgf in full range.

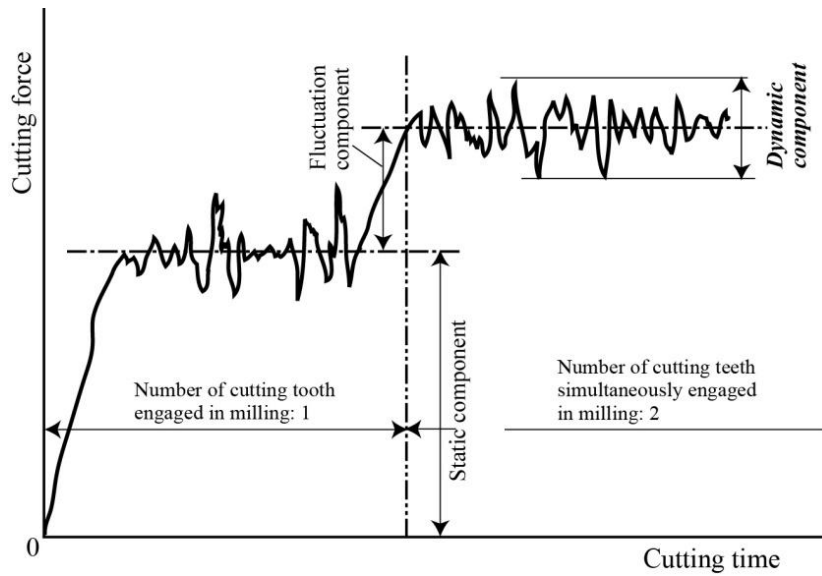

Fig. 3. Static, fluctuation and dynamic components in cutting force

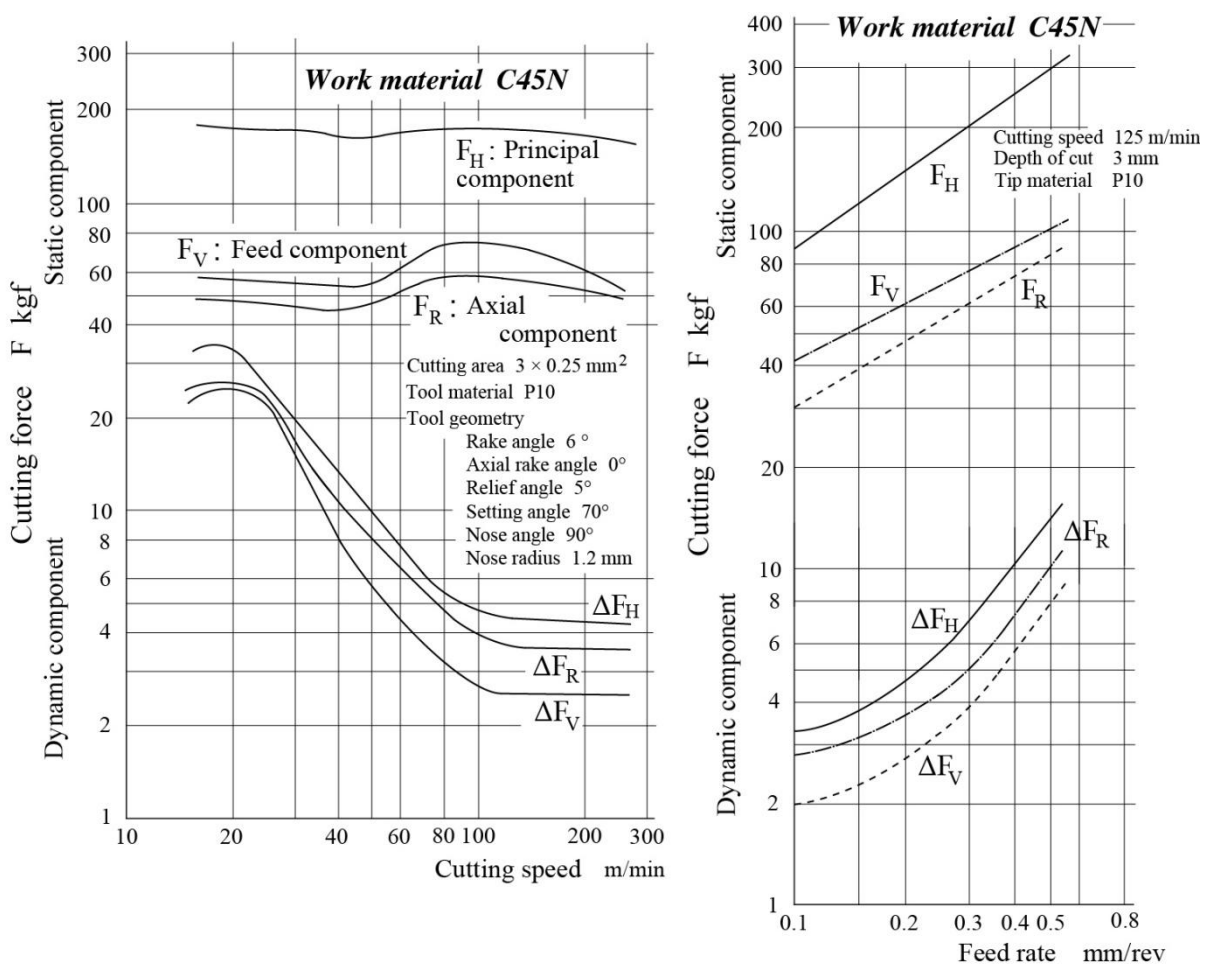

Fig. 4. Static and dynamic components of cutting force in turning (by Langhammer)

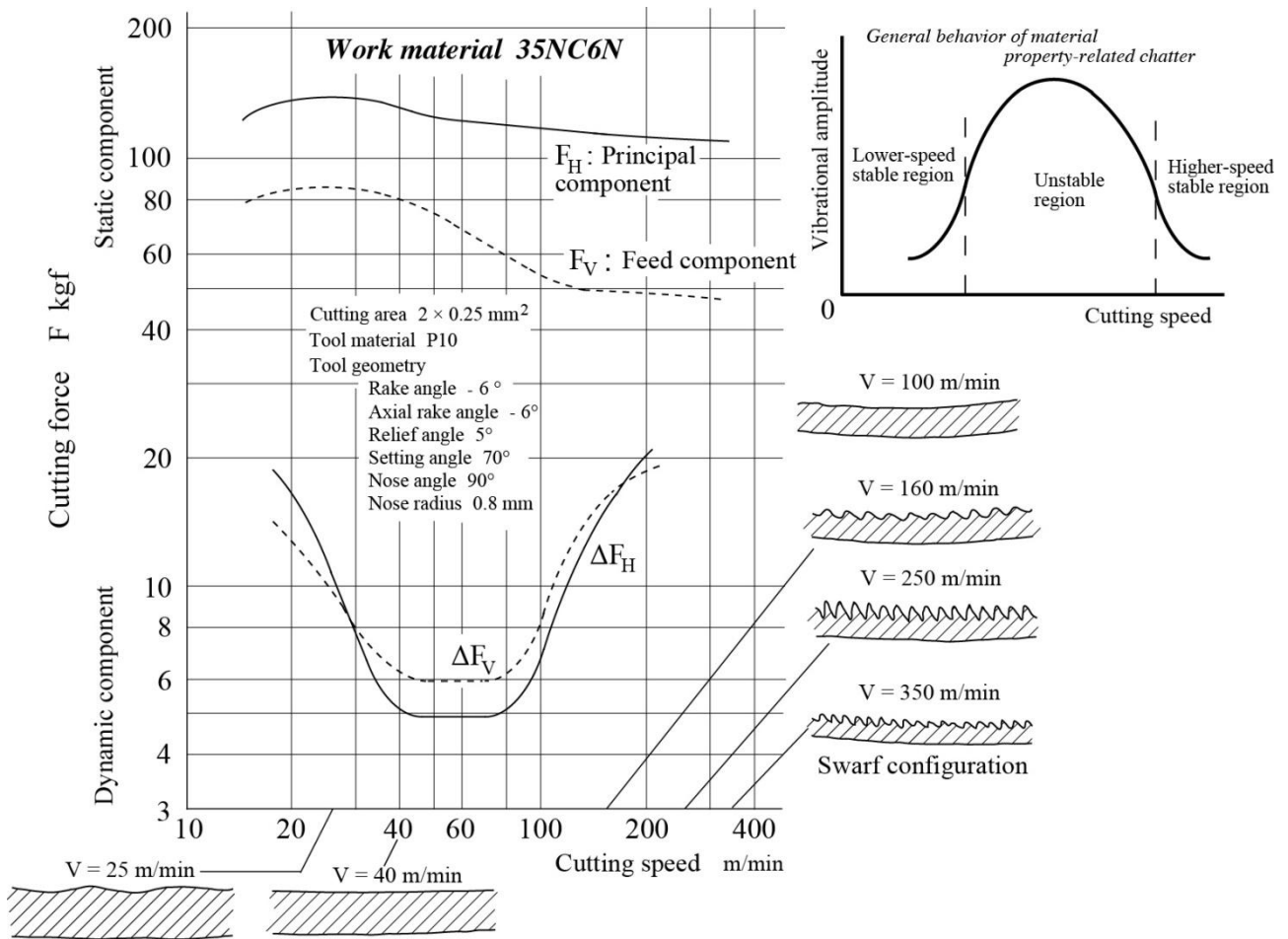

Fig. 5. Correlation between stable region in chatter and dynamic component in cutting force when machining heat-resistant steel (by Langhammer)

Figure 5 demonstrates an implication in a capability of the dynamic component in cutting force for verifying the validity of the “Penetration Effect“. As can be seen from the top-right illustration, the behavior of dynamic component is in good agreement with the qualitative stability chart in this case. In fact, the smaller magnitude of the dynamic component, the larger is chatter vibration.

2.2. MODIFICATION OF “BLOCK DIAGRAM OF CHATTER LOOP“ PROPOSED BY MERRITT

Apart from some questioned points in the dynamic cutting force mentioned above, Merritt proposed a convenient tool to solve the self-excited chatter by using the control theory [6]. For the simplified machine-tool-work system shown in Fig. 6, three basic expressions can be written as

$$u(t) = u_0(t) - y(t) + \mu y(t-T) \tag{4}$$

$$F(t) = k_c u(t) \tag{5}$$

$$F(t) \cos\beta = m(d^2/dt^2)y(t) + c(d/dt)y(t) + ky(t) \tag{6}$$

where,

c = Damping coefficient

$F(t)$ = Resultant cutting force or vector force exciting structure

k_c = Static cutting stiffness (specific cutting force)

k = Spring constant of structure

m = Equivalent mass of structure

N = Spindle speed

T = Delay time ($1/N$ for lathe)

t = Time

u = Instantaneous uncut chip thickness

u_0 = Steady-state uncut chip thickness

y = Relative displacement between tool and work

μ = Overlap factor

By applying the Laplace Transformation, these yield to

$$u(s) = u_0(s) - y(s) + \mu e^{-Ts}y(s) \quad (7)$$

$$F(s) = k_c u(s) \quad (8)$$

$$y(s)/F(s) = (1/k)G(s) \quad (9)$$

where,

G = Normalized dynamic compliance of structure

s = Laplace operator

Then we can obtain the ‘‘Block Diagram of Chatter Loop’’ shown together in Fig. 6, and after determining the ‘‘Loop Transfer Function’’, we can produce the ‘‘Stability Chart’’. Importantly, the ‘‘Block Diagram of Chatter Loop’’ is very useful tool to understand the essential feature and leading influencing factors in the self-excited chatter. For example, we can consider (1) the ‘‘Contact Stiffness of Grinding Wheel’’, (2) ‘‘Grinding Stiffness and Damping’’, and (3) ‘‘Anti-wear Stiffness of Grinding Wheel’’ in the chatter loop for grinding [7]. More importantly, the grinding wheel may generate the wavy surface when the grinding stiffness is larger than its anti-wear stiffness, and it may be interpret that such waviness induces the forced vibration.

As will be clear from this exemplification, the chatter loop proposed by Merritt should be modified as follows.

- (1) As a minimum requirement, the uncut chip thickness equation should be revised in consideration of the ‘‘Primary Multiple-regenerative Effect’’, i.e.,

$$u(t) = u_0(t) - y(t) + \mu_1 y(t-T) + \mu_2 y(t-2T)$$

- (2) By incorporating the forced vibration as the unfavorable disturbance, we must estimate the deterioration magnitude of the chatter stability. In short, the cutting process equation should be modified as follows.

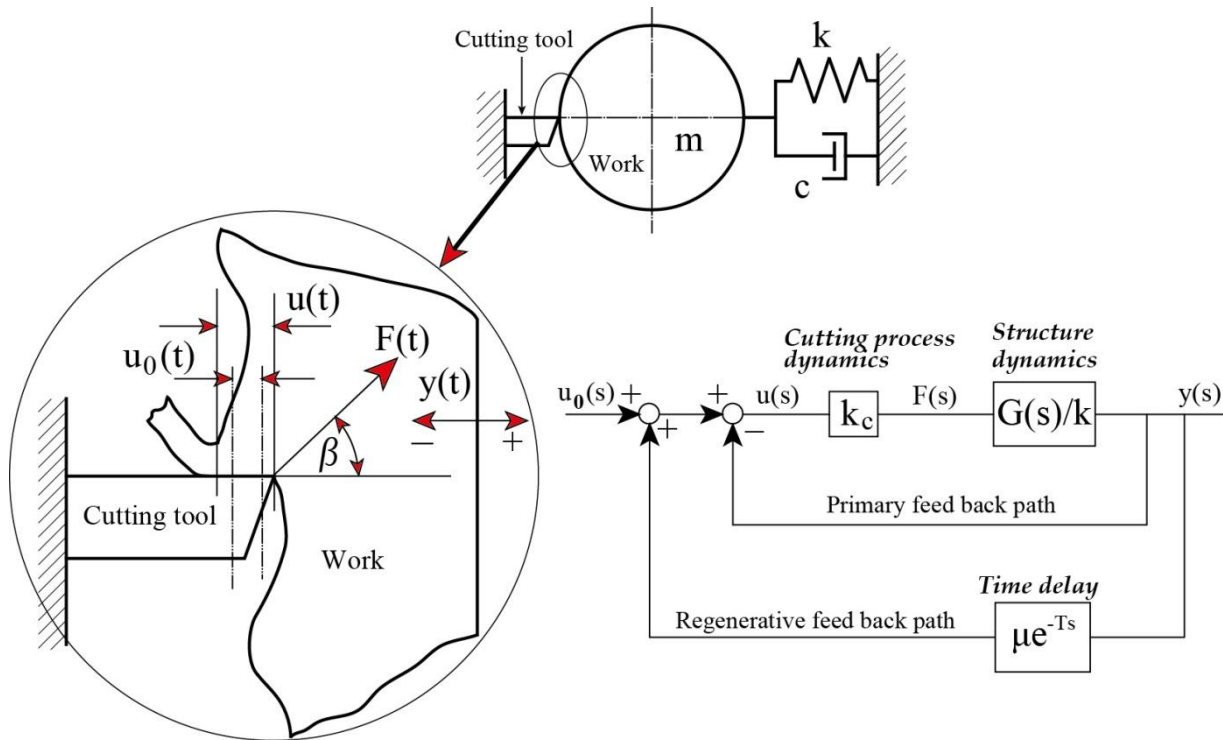

Fig. 6. Mathematical model and block diagram of chatter loop for self-excited chatter vibration (by Merritt)

$$F(t) = k_c u(t) + f_0 \sin \omega t \text{ (forced vibration) , } t = 2\pi/\omega$$

- (3) As will be discussed later in detail, the structural equation may be further generalized by incorporating, for example the “Directional Orientation in Chucking Stiffness“, and “Non-linearity in Stiffness of Structural Body Component“. In the case of work holding by the three-jaw chuck, the structural equation yields to

$$F(t) \cos \beta = m(d^2/dt^2)y(t) + c(d/dt)y(t) + (k + k_w \sin 3\omega t)y(t)$$

where, k_w = Average stiffness of chuck-work system

As widely known, this expression results in the “Mathieu Differential Equation“.

3. FIRST-HAND VIEW FOR ANOTHER ISSUES TO UNVEIL FURTHER ESSENTIAL FEATURES OF SELF-EXCITED CHATTER

Admitting that we can appreciate the very noteworthy achievements of Tobias, Tlustý and Merritt, we must simultaneously be aware of some new findings obtained from a certain number of thought-evoking research reports. On the basis of such new findings, it is expectable to unveil the further essential features of the self-excited chatter vibration. More specifically, from such reports author can suggest some leading issues as follows.

- (1) What is the leading causality of the self-excited chatter vibration and is it possible to define absolutely and definitely the chatter commencement? In nearly all publications, there are no descriptions for how to define the chatter commencement.
- (2) In turning, we must investigate the influence of the work holding condition on the stability chart. In accordance with our long-standing experience, the stability chart varies considerably by the work holding condition, although nearly all publications don't state it in detail. For example, the three-jaw chuck is, as mentioned above, capable of mingling the parametric vibration in the self-excited chatter, and the work with knurled gripping surface increases much more the stability limit than that with finish-turned one.
- (3) At burning issue is the "Lower-speed Stability due to Process Damping". Is it true that the lower-speed stability is derived from the "Process Damping"? Reportedly, the magnitude of damping at the machine tool joint is not so large enough to suppress the chatter, and the work-tool contact point appears as to be one of the machine tool joints. Within this context, it is necessary and inevitable to measure or visualize the contact condition between the flank of cutting tool and the work. Reportedly, Spur and Leonard [8], and also Itoh et al [9] once tried the in-process measurement of the flank wear by means of the ultrasonic waves.

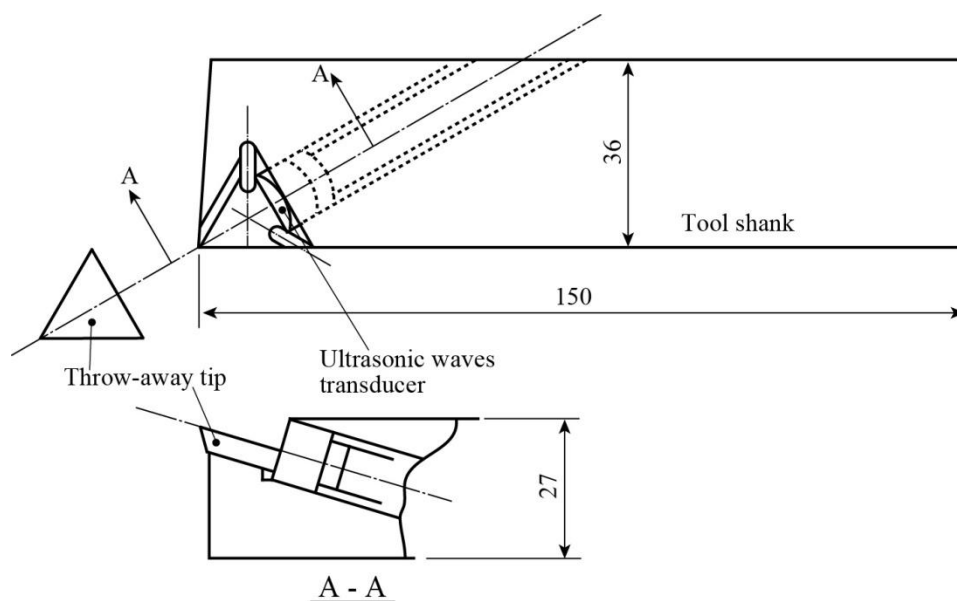

Fig. 7. In-process sensor of built-in type to measure flank wear by using ultrasonic waves

Spur and Leonard measured the flank wear by using the response time of the ultrasonic waves, whereas Itoh et al used the change of the sound pressure to improve the measuring accuracy. As will be clear from the above, it should be furthermore verified that the lower-speed stability increases when the contact area of flank becomes larger. Fig. 7 is a schematic view of the in-process sensor developed by Itoh et al. Within the "Process Damping" context, furthermore, we have a representative case study recently, and thus will discuss it in the Appendix for the sake of further understanding.

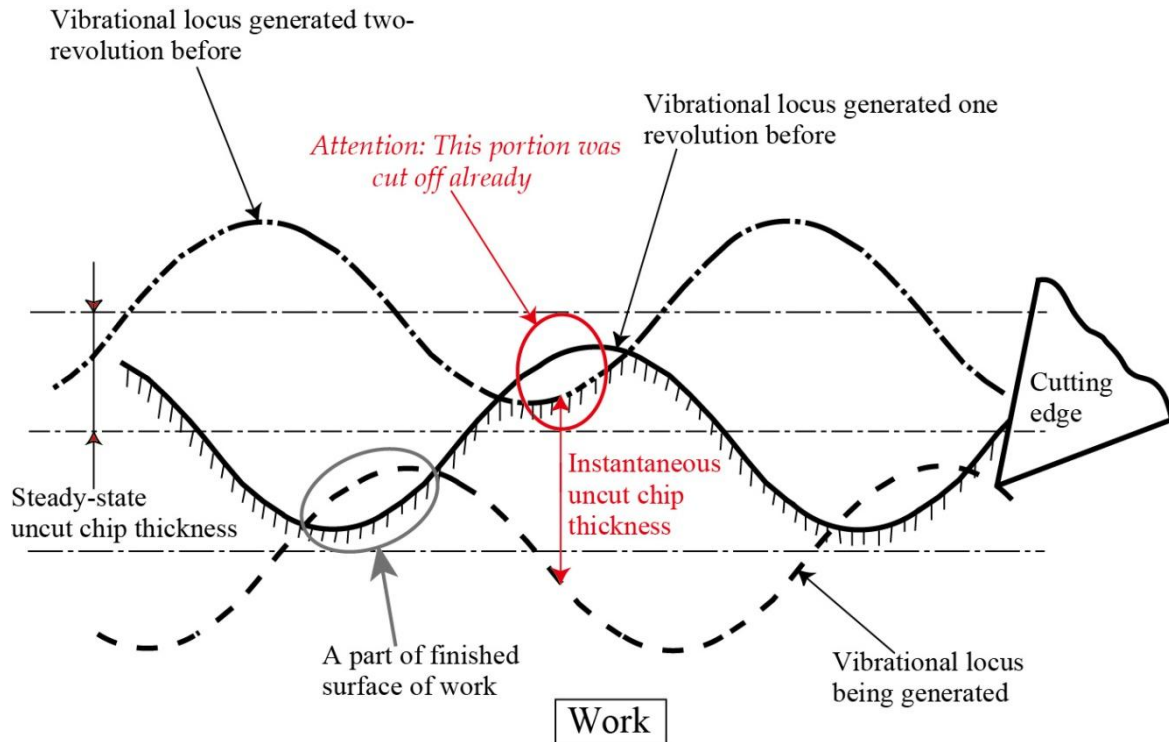

Fig. 8. Concept of “ Multiple-regenerative Effect “ in self-excited chatter (by Kondo, H. Sato et al.)

- (4) What are the advantages and disadvantages of the “Multiple-regenerative effects“? Reportedly, the first proposer is credited to Kondo and H. Sato et al of The University of Tokyo in 1980, and he conceptualized it as shown in Fig. 8 [10]. In short, we may associate the multiple-regenerative effect with the continuing chatter vibration in constant amplitude, and such a cutting condition has been practically used in rough cutting.
- (5) In drilling, we must evaluate the effects of the body clearance and chisel point, which may increase damping within the machine-tool-work system.
- (6) Investigation into the general behavior of the torsional self-excited chatter in grinding.
- (7) Is it possible to ignore the influence of the magneto-strictly vibration of the driving motor ? In fact, the fluctuation or slip of the rotational speed of main spindle is very small nowadays by the advance of the motor technology. In contrast, we must be aware of certain influence caused by the loosening fit between the rotor and main spindle in the built-in-motor.

For the sake of further understanding, some quick notes for two crucial issues will be discussed in the following.

3.1. DEFINITION OF CHATTER COMMENCEMENT

Firstly, Fig. 9 reproduces a measured result of Braun of Israel Institute of Technology, and as can be clearly seen, it is very difficult to identify the chatter commencement from the

original signal of chatter vibration. Thus, Braun extracted a characteristic index called “Magnitude Plot“ by processing the original signal, and identified the chatter commencement, where the “Magnitude Plot“ drops suddenly as shown in the bottom of Fig. 9 [11]. As exemplified by that of Braun, we have, in general, certain difficulties to correctly identify the chatter commencement by only using the original chatter signal. We must thus contrive (1) the desirable transducer to measure the chatter signal with less noise even in the machining space, and (2) preferable method for signal processing. After then, we must determine (3) an evaluation index, which represents rationally and correctly the chatter commencement.

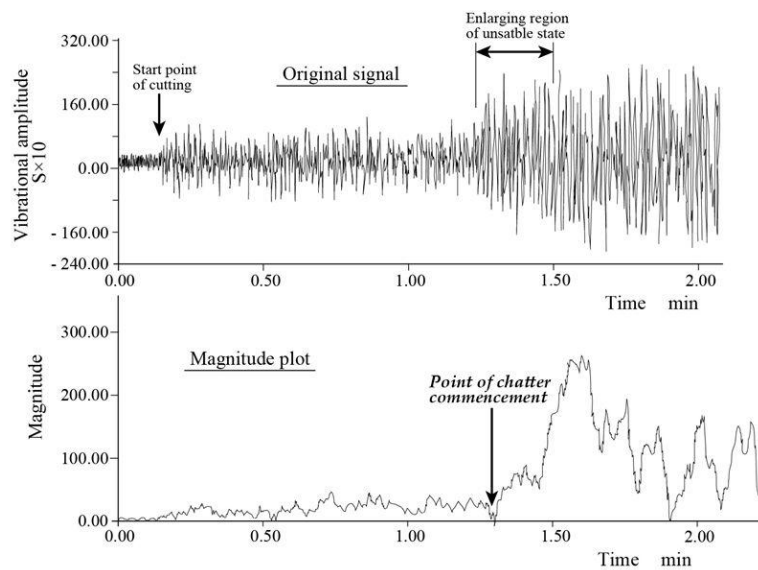

Fig. 9. A trial to determine chatter commencement (by Braun)

In consideration of the ill-defined and uncertain aspects of the self-excited chatter, we must recognize that the facing problem to define the chatter commencement authentically becomes much more difficult than the determination of the stable-unstable criterion in other engineering problems. For example, Altintas and Weck published a review report in 2004 [12], and from it we can recognize that nearly all research papers and technical reports so far publicized did not pay any attentions to the definition of the chatter commencement. Apparently, these publications consider that the chatter commencement can be automatically determined without any problems. Within this context, Rahman once publicized a very interesting report, in which the chatter commencement depends considerably upon what is the characteristic index and also how to detect it. He conducted a research into the chatter commencement by independently detecting (1) the vibrational amplitude, (2) cutting force, (3) work displacement, and (4) surface roughness of finished work.

In addition, he employed the tapered workpiece, which was proposed by The Machine Tool Industry Research Association, England. This tapered workpiece was once investigated to enact a standard for the dynamic performance test of the engine lathe. Fig. 10 reproduces his valuable suggestion, and from it we can understand the very difficulties in the determination of the chatter commencement as follows [13].

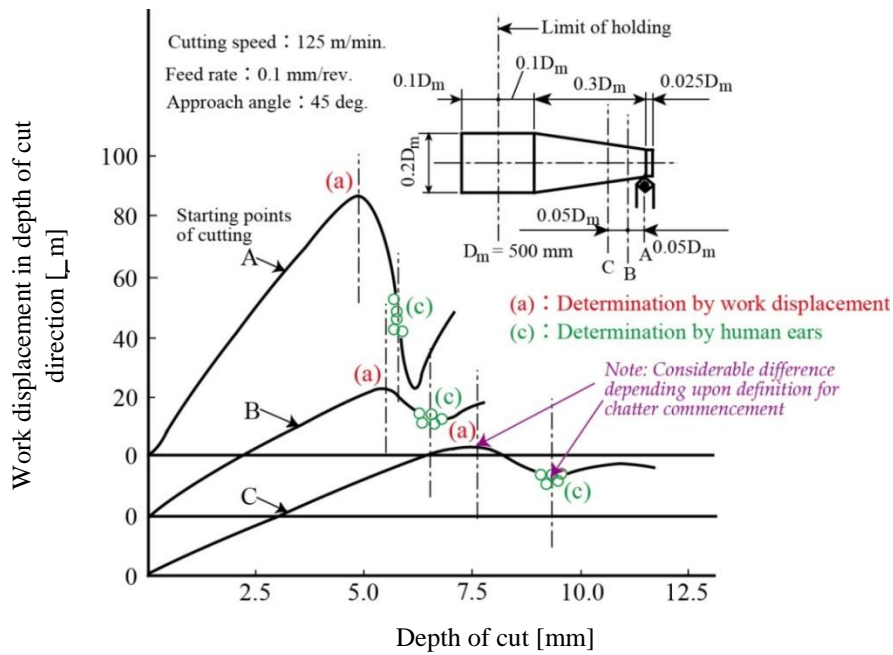

Fig. 10. Determination of self-excited chatter commencement using characteristic behavior in displacement of work (by Rahman et al)

- (1) A characteristic behavior can be observed in the work displacement in horizontal direction (depth of cut direction) at the chatter commencement. More specifically, the horizontal displacement of the work launches out to the reduction as marked with “a” in Fig. 10, although the depth of cut increases continuously.
- (2) The point, where the horizontal displacement of the work is about to decrease, is identical to the point, where the surface finish becomes worse. In contrast, the vibrational amplitude shows any marked changes at this point.
- (3) The detection of the chatter commencement by human ears is later than that by the horizontal displacement. For example, we can recognize about 2.5mm different in the depth of cut.

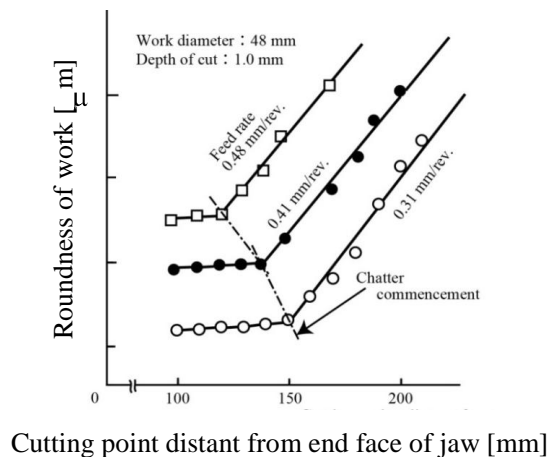

Fig. 11. Determination of chatter commencement using deterioration of work roundness as index (by M. Doi et al)

Following the earlier research work, in 2010 Denkena has quickly stated that he determined the chatter commencement in end milling by totally using the information obtained from the visual inspection, surface roughness of finished work, sound and vibration while machining, and deflection of tool holder [14]. As will be clear from the above, it is incredible that some researchers assert the good agreement between the theoretical and experimental stability charts without clearly stating how to determine the chatter commencement. In contrast, it is now worth suggesting that one of crucial issues in the self-excited chatter is to define rationally and to determine correctly the chatter commencement.

To this end, a quick note will be given to understand the first-hand view for the earlier research into the chatter commencement.

- (1) Nakazawa et al conducted a research similar to that of Braun by detecting the sound or acceleration signal of vibration in 1979 [15].
- (2) Following that of Braun, Higuchi et al [16] and Nicolescu [17] investigated the chatter commencement by using similar methods to that of Braun. In fact, the former detected the sound signal with time-series processing, and the latter detected the mean-square value of vibrational amplitude. It is very interesting that Higuchi et al reported the same result as that of Rahman.
- (3) Yeh et al proposed a method, in which signal processing is based on the average value of vibrational amplitude together with using the double threshold. By it, the detection accuracy becomes better than other methods [18].
- (4) M. Doi and Muroya proposed furthermore to use the deterioration rate of roundness of the work as an evaluation index of the chatter commencement. Fig. 11 reproduces one of the experimental results, and as can be readily seen, the roundness of the work deteriorates amazingly by the chatter commencement. Importantly, they also reported that the flatness deviation behaves like the roundness in the case of plane machining by MC [19].

3.2. SELF-EXCITED CHATTER MINGLING WITH PARAMETRIC VIBRATION

In retrospect, within the self-excited chatter in turning, nearly all research reports state that the facing problem should be dealt with from the viewpoint of machine-tool-work system; however, without obviously describing the chucking condition of the work, they asserted also the good agreement between the theoretical and experimental stability charts. In other words, there remain certain uncertainties regarding whether the experimental boundary condition is identical with theoretical one or not.

For example, the three-jaw chuck shows very different features from those of the four-jaw chuck. In fact, the work holding stiffness of the three-jaw chuck varies three times every one rotation of the main spindle, resulting in the directional orientation effect of the work stiffness. Eventually, such a directional orientation causes a parametric vibration, and it appears that the stability limit for the self-excited chatter deteriorates considerably. More specifically, Fig. 12 reproduces the chatter mark for the chucked work in protruded

configuration, and we can observe some interesting behavior as follows [20].

- (1) The chatter commencement differs from each other depending upon the jaw position.
- (2) By observing the chatter mark with the three-dimensional surface roughness measurement, as shown together in Fig. 12 with enlarged view, the “Scale-like mark“ exists obviously at the slope of the self-excited chatter mark.

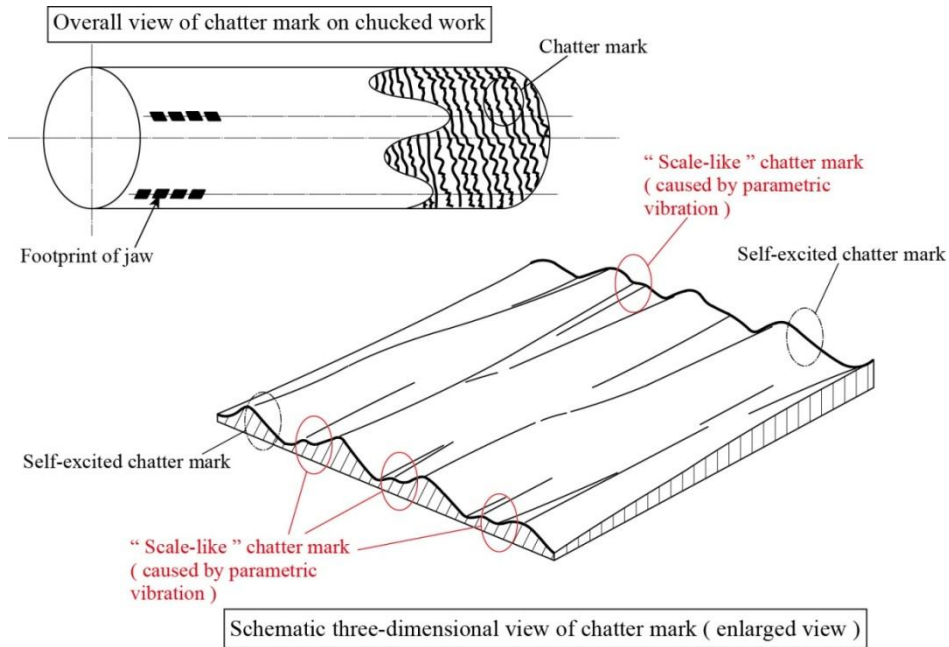

Fig. 12. Superimposing “Scale-like Mark“ on self-excited chatter mark (by M. Doi et al)

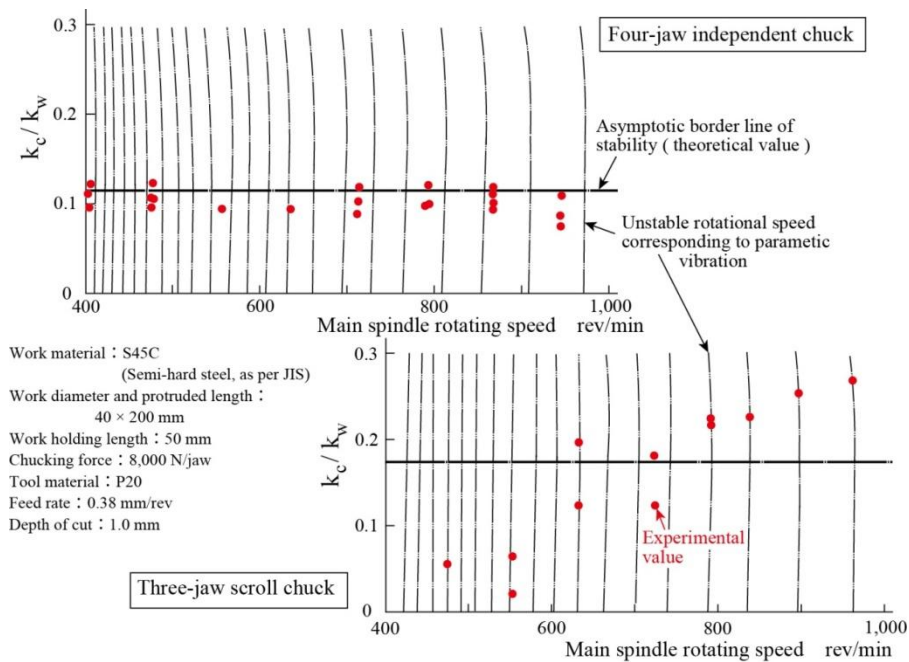

Fig. 13. Deterioration of stability limit by mingling with parametric vibration (by M. Doi et al)

Having in mind the considerable influence of the parametric vibration caused by the jaw chuck, Fig. 13 demonstrates a comparison of the theoretical asymptotic borderline of stability for work held by the three-jaw scroll chuck with that by four-jaw independent chuck. Of note, the chatter stability is evaluated by the index k_c/k_w , where k_c and k_w are the cutting stiffness and average stiffness of chuck-work system, respectively, and the experimental value of stability limit is also shown in Fig. 13 [21].

From Fig. 13, we can observe the very interesting behavior as follows.

- (1) In the case of four-jaw independent chuck, all the experimental values can be plotted to be closer to the theoretical asymptotic borderline, and thus it may be concluded that there are no influences of the parametric vibration.
- (2) In the case of three-jaw scroll chuck, the experimental values are plotted far lower at lower spindle speed and higher at the higher spindle speed than the asymptotic borderline, respectively. The experimental value at higher spindle speed corresponds well with that of parametric vibration.

In addition, M. Doi et al suggested the larger influence of jaw travelling mechanism on the chatter stability by comparing the four-jaw independent chuck with that of scroll type. It is thus recommendable to conduct the research by using the large-sized collet chuck, which has less directional orientation effect than chucks of another types, although we cannot find such a challenging research as yet.

4. CONCLUDING REMARKS

Although having been observed a considerable number of new findings in the chatter vibration while machining, nearly all researches are even now carried out on the strength of the achievements of Tobias, Tlustý and Merritt. We must thus challenge actively to develop some new views, by which the essential feature of the chatter vibration is clarified much more than ever before. As mentioned in this paper, we must eye the facing problem with the synthetic and holistic ways from both the theoretical and experimental aspects. On such an occasion, we must use positively the knowledge obtained already in other spheres of manufacturing technology, but not limiting within the chatter vibration realm.

In the utmost preferable case, it is expectable to establish a generalized block diagram of chatter loop.

REFERENCES

- [1] ARNOLD R. N., 1946, *The mechanism of tool vibration in the cutting of steel*, *Cutting tools research*: Report of Subcommittee on Carbide Tools, Proc. I Mech E., 261-284.
- [2] TLUSTÝ J., 1970, *Chapter 2 The theory of chatter and stability analysis*, In: Koenigsberger F, Tlustý J (eds) *Machine Tool Structure*, 1, Pergamon Press, 133-177.
- [3] STONE B. J., 1970, *The effect, on the regenerative chatter behaviour of machine tools, of cutters with different approach angles on adjacent teeth*, Research Report, 34, The MTIRA (Confidential to Members of M.T.I.R.A.).
- [4] TOBIAS S. A., 1961, *Schwingungen an Werkzeugmaschinen*, Carl Hanser Verlag.
- [5] LANGHAMMER K., 1972, *Die Zerspankraftkomponenten als Kenngrößen zur Verschleißbestimmung an Hartmetall-Drehwerkzeugen*, Dissertation der RWTH Aachen, and OPITZ H, et al., 1970, *Statische und dynamische Schnittkräfte beim Drehen und ihre Bedeutung für den Bearbeitungsprozess*, Forschungsberichte des 22ands Nordrhein-westfalen, Nr. 2144 Westdeutscher Verlag.

- [6] MERRITT H. E., 1965, *Theory of self-excited machine-tool chatter, contribution to machine-tool chatter research-1*, Trans. of ASME Jour. of Engg. for Industry, 447-454.
- [7] FURUKAWA Y., 1975, *Chatter vibration and its suppression*, 2 Day-long Course on Basic Technology in Machining, 411, JSME.
- [8] SPUR G., LEONARDS F., 1975, *Sensoren zur Erfassung von Prozesskenngrößen bei der Drehbearbeitung*, Annals of CIRP, 1975, 24/1, 349-354.
- [9] ITOH S., et al., 1991, *Ultrasonic waves method for tool wear sensing – in-process and built-in type*, In: Proc. of Inter. Mech. Engg. Congress, Sydney, 83-87.
- [10] KONDO S., et al., 1980, *Behaviour of self-excited chatter vibration in consideration of multiple-regenerative effects*, Trans. of JSME, 46/409,1024-1032.
- [11] BRAUN S., 1975, *Signal processing for the determination of chatter threshold*, Annals of CIRP, 24/1, 315-320.
- [12] ALTINTAS Y., WECK M., 2004, *Chatter stability of metal cutting and grinding*, CIRP Annals - Manufacturing Technology, 53/2, 619-642.
- [13] RAHMAN M., ITO Y., 1979, *A method to determine the chatter threshold*, In: Proc. of 19th Inter. MTFR Conf., MacMillan, 191-196.
- [14] DENKENA B., DE LEON L., GROVE T., 2010, *Prozessstabilität eines kordelierten Schaftfräasers*, ZwF, 105/1/2, 37- 41.
- [15] NAKAZAWA H., MIYOSHI Y., SHIGEMURA K., 1979, *Detection of chatter commencement – 1st report*, Jour. of JSPE, 45/11, 353-1358.
- [16] HIGUCHI M., DOI M., MASUKO M., 1986, *Determination of chatter commencement in turning*, Trans. of JSME (C), 52/477, 1697-1700.
- [17] NICOLESCU C.M., 1991, *Analysis, identification and prediction of chatter in turning*, Doctoral Thesis No. 18, Department of Production Engineering, Royal Institute of Technology, Stockholm.
- [18] YEH L.J., LAI G.L., ITO Y., 1992, *A study to develop a chatter vibration monitoring and suppression system while turning slender workpieces*, In: Proc. of 2nd Inter. Conf. on Automation Tech. 2, 337-343, Taipei.
- [19] DOI M., MUROYA Y., 1990, *Development of dynamic performance test for lathe*, Trans. of JSME (C), 56/529, 2521-2526.
- [20] DOI M., MASUKO M., ITO Y., 1982, *Re-observation of the chatter vibration in chuck works – effects of jaw number on the appearance of a scale-like chatter mark*, In: Proc. of 10th NAMRI of SME, 409 – 416.
- [21] DOI M., et al., 1985, *Study on parametric vibration in chuck work*, Trans. of JSME (C), 51/463, 649-655.

APPENDIX – RESEARCH INTO PROCESS DAMPING BY ALTINTAS ET AL

Altintas et al have recently publicized a report for the process damping, and asserted that the process damping force may be caused by the contact between the relief angle of cutting tool and the waviness generated by the chatter vibration. More specifically, they have detailed two types of the damping force, i.e., those related to (1) the contact with the slope of waviness, $(dx/dt)/V$, and (2) the contact with curvature of waviness, $(d^2x/dt^2)/V^2$, where V is the cutting speed. Obviously, we can expect the larger lower-speed stability, when we assume such process damping force, as can be estimated from the proposal of Tobias [AP-1].

Figure AP-1 reproduces a research result with respect to the stability chart, and we can see some interesting behavior as follows.

- (1) As expected, the lower-speed stability can be obviously observed.
- (2) The lower-speed stability with velocity terms is larger than that with velocity and acceleration terms. This implies that process damping caused by the acceleration term has negative effects.
- (3) As expected, the lower-speed stability can be obviously observed.
- (4) The lower-speed stability with velocity terms is larger than that with velocity and acceleration terms. This implies that process damping caused by the acceleration term has negative effects.

It is noteworthy that they asserted that the theoretical stability chart is in good agreement with the experimental one, but it is doubtful as can be seen from Fig. AP-1.

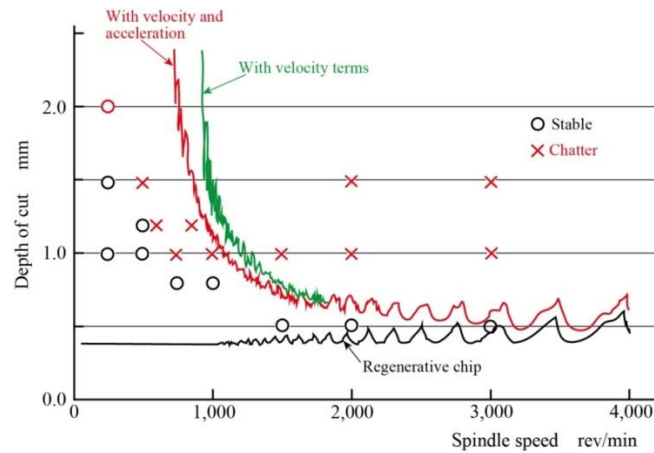

Fig. AP-1. Stability lobes with and without process damping terms (by Altintas et al)

In this context, Altintas et al are requested to state obviously and clarify why they can classify the two type of the damping mechanism; however, they did not state anything. In addition, another questioned point is how to define the commencement point of the chatter vibration. From the experimental data, there is uncertainty in such the definition.

Following that of Altintas et al, Sellmeier et al have also conducted similar studies [AP-2], and we may have several disputed points in these reports, and thus will discuss them in the following.

Is measured value of process damping acceptable?

Within this context, Altintas et al have reported that they can measure process damping while cutting [AP-1]. This report is very interesting and amazing; however, we must remember that the damping capacity is, in general, very difficult to measure without receiving the influence of the damping capacity of surrounding components as proved in the measurement of damping capacity of the machine tool joint. In fact, the contact point between the flank of cutting tool and the finished surface is one of the machine tool joints. More specifically, Saljé and Isensee measured, for example, the damping capacity of the center by exciting the mid-way of the slender work, which was supported its both the ends by the centers [AP-3]. In many respects, the damping capacity of surrounding components could include in the measured values, and of course, it is very difficult to eliminate such unfavorable noises without using, at least, the equivalent monolithic center system. Thus, Saljé and Isensee reported some comparative damping capacity, but not the real one. Of these measured values, the damping capacity for the axial force of 1,000kgf is 0.005 in damping rate, which is equivalent to 0.03 in logarithmic damping decrement by the simple conversion. This magnitude is only several times of the material damping of cast iron. Of note, Tsutsumi of Tokyo Agricultural Technical University reported that the logarithmic damping decrement of HSK, one of the prevailing tool holding systems, is between 0.01 ~ 0.03. It is thus natural to estimate relatively small damping force at the cutting edge.

Against to this context, someone asserts that the contact condition of cutting point

differs from the machine tool joint; however, it may be said that the sliding condition at the tool flank is not severe as compared with that at the rake face, where the apparent contact area appears as to be the same as the real contact area. In fact, the flank wear can be measured by means of ultrasonic waves as already shown in Fig. 7. In addition, Jochem et al has suggested it not only in turning, but also in drilling that the process damping becomes larger with the higher contact density, and that the higher contact density results from the shorter pitch of waviness obtainable at the lower-cutting speed [AP-4]. Reportedly, much more number of the contact points in the joint surface, the less damping and more rigidity are the characteristics of the joint in general. As mentioned above, the contact between the flank face and the work can be regarded as one of the machine tool joints, and thus this suggestion is very interesting, because of asserting a new contact state at the cutting point. Within the academic research context, it is basically necessary that Jochem et al must explain why they assert such a new characteristics or must prove experimentally the validity of their assertions.

Summarizing, the evidence reported by the group of Altintas is very interesting, provided that other researchers should support their assertion, otherwise there remains something to be seen.

Is test rig applicable to the measurement of process damping?

Another issue is the validity of the test rig for measuring the dynamic cutting force coefficient. In fact, the test rigs of Altintas et al and Sellmeier et al are those for vibrational cutting with exciting phase control, although they assert that the dynamic cutting force can be measured by such test rigs. More specifically, Altintas et al used the test rig for orthogonal plunge turning, in which the piezo-actuator-driven fast tool servo can control the vibrating frequency and amplitude of the cutting tool, and the laser sensor can facilitate the measurement of cutting tool displacement. In contrast, Sellmeier et al used the milling machine of travelling spindle type, in which the milling head is supported by the active magnetic guides and driven by the linear motor. In the experiment, the spindle was sinusoidal-excited with amplitude control, and the cutting force was measured by the dynamometer of Kistler-make while end milling.

In retrospect, these test rigs are those for vibrational cutting so far developed in USSR and Japan [AP-5], and as can be seen, they measured only the cutting force in vibrational cutting, which is not identical with the dynamic cutting force while self-excited chattering. Thus, Altintas and Sellmeier et al are requested to prove the validities of their assertions by providing us with the obvious refutation.

[AP-1] ALTINTAS Y., EYNIAN M., ONOZUKA H., 2008, *Identification of dynamic cutting force coefficients and chatter stability with process damping*, CIRP Annals – Manufacturing Technology, 57, 371-374.

[AP-2] SELLMEIER V., HACKELOEER F., DENKENA B., 2009, *Process damping in milling – measurement of process damping forces for chamfered tools by means of an electromagnetically guided spindle*, 12th CIRP Conf. on Modelling of Machining Operations, Donostia-San Sebastian, 911-919.

[AP-3] SALJÉ E., ISENSEE U., 1976, *Dynamische Verhalten schlanker Werkstücke bei unterschiedlichen Einspannbedingungen in Spitzen*, Zwf, 71/8, 340-343.

[AP-4] JOCHEM C., ROUKEMA, ALTINTAS Y., 2006, *Time domain simulation of torsional-axial vibrations in drilling*, Inter. Jour. of Machine Tools & Manufacture, 46, 2073-2085.

[AP-5] KUMABE J., 1979, *Precision machining – vibration cutting: its fundamentals and applications*, Jikyuu Shuppan.