

Development Trends for Automatic Train Protection systems

Sławomir Barański*
Henryk Karbowski**

Received April 2013

Abstract

The elaboration shows basic requirements fulfilled by controlling devices, together with work sequences of each particular configuration. These devices are commonly used in railway and subway networks and they ensure traffic safety on the stations and routes. The train however, is driven by engine-driver who observes indications on semaphores and undertakes certain decisions in drive and brake control. The guarantee of safe train operation is achieved by introducing automatic train protection system – ATP.

Principle of operation, shown as a graph, have been discussed, as well as ATP systems development course, based on constant data transmission channels, mainly the rail duct that uses modern rail track and newly introduced radio channel. Significant improvements in parameters of transmission channel by using jointless rail track have been emphasized. Necessity of using point transmission to forward constant rail marks that are essential for train's self-localization has been indicated. Selected properties of different ATP systems are presented in chart.

1. Introduction

Key elements enabling train traffic are: railway, railway vehicle and the broadly defined Integrated Control Room. The train traffic (trains themselves, train handling) at the railway station and operating control point is managed from the signal box operated by traffic controller. Between stations, trains are controlled by traffic controllers located at neighbouring stations. Train driver uses parameters of the route and rail vehicle as well as signals sent by the traffic controller via the signal lights to drive the train.

* Lodz University of Technology, 90-924 Łódź ul. Stefanowskiego 18/22

** University of Humanities and Economics in Lodz, 90-222 Łódź ul. Rewolucji 1905 r. 64

It is the responsibility of the traffic controller to prepare routes for trains and train handling. For that purpose Integrated Control Rooms are built (e.g. signal box), equipped with traffic control devices [4], which enable the traffic controller to safely guide train traffic and feeding relevant information to the rail vehicle, thus making possible to drive train along particular railroads.

2. Traffic Safety Ensured by the Rail Traffic Control System

Preparing a route in a safe manner takes place according to the following algorithm [7]:

- detect non-occupancy of railway and crossover along particular routes;
- dismiss conflicting routes;
- check line block status for travels to neighbouring stations;
- associate elements (points, derailleurs) of routes with statuses required for that particular route;
- status setting (setting particular status) for given route elements;
- give clear signal allowing to take particular route.

Switching points is possible (permissible) when:

- the point is not part of the route, neither currently planned and in-progress i.e. for which the clear signal was given until the route becomes clear;
- there are no vehicles at the crossover;
- the vehicle approaching points (e.g. during handling) from distance allowing the switch mechanism to completely set and lock, before the train passing.

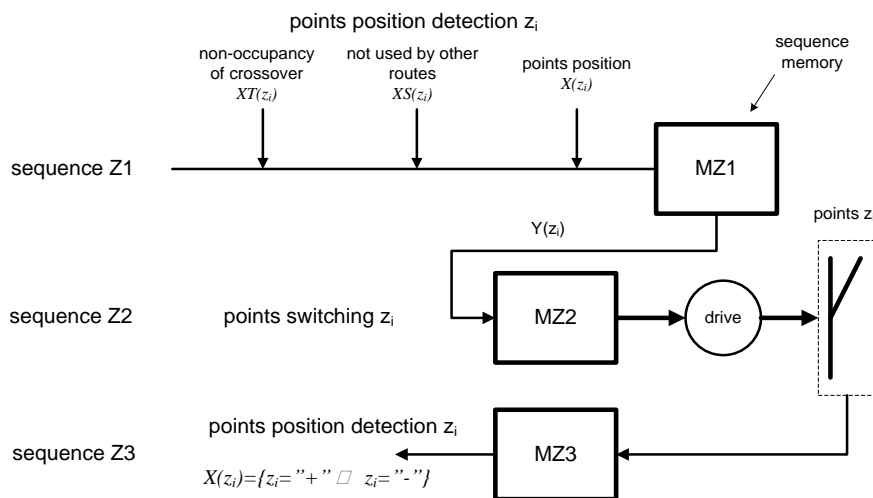

Fig. 1. Points switching sequences

Railroad switching takes place in three sequences Z - fig. 1:

- Z1 sequence - points switching conditions are checked - MZ1 memory;
- Z2 sequence - points are switched in adequate time from one position e.g. "minus" to another "plus" - MZ2 memory;
- Z3 sequence - point blades position after switching is checked; mechanism sensors send signal to railway points sensors and then to other relevant devices - MZ3 memory.

Prior to giving the clear signal on the route Xdp , its status has to be checked. Those conditions are fulfilled over the following route sequences - P (fig. 2):

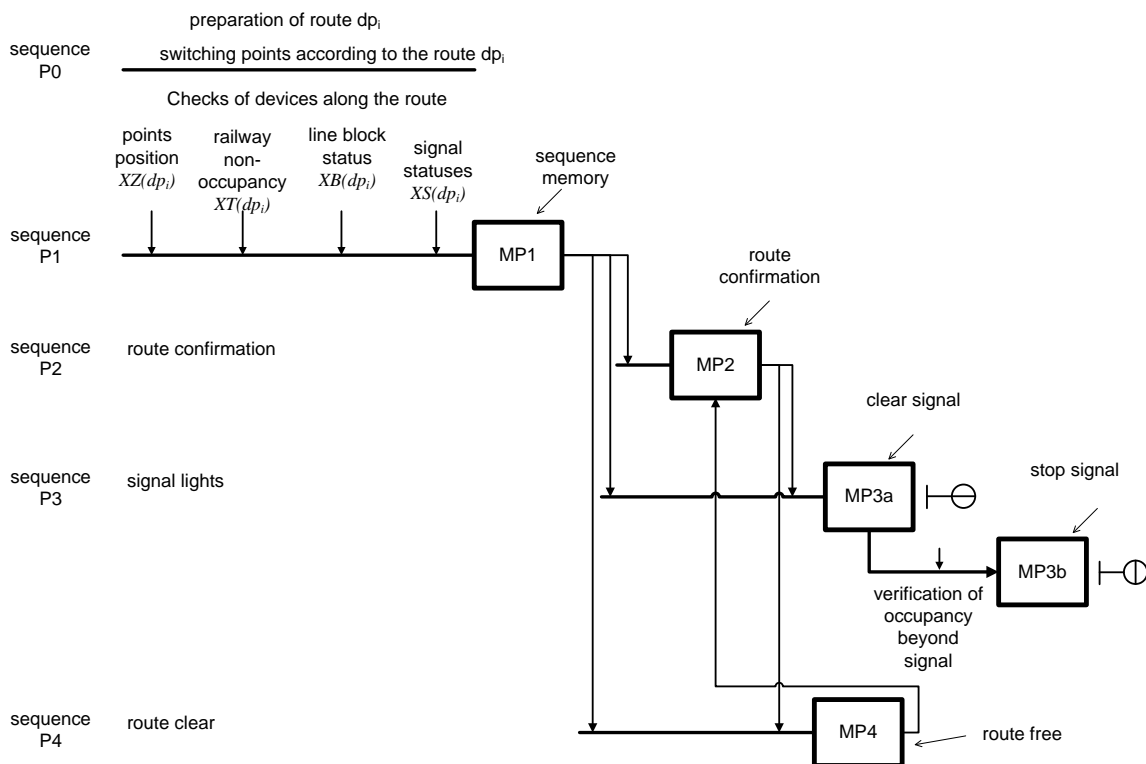

Fig. 2. Routing and signal light sequences

- P0 sequence, preliminary routing, e.g. by locking points in correct position;
- P1 sequence, railway and crossover non-occupancy detection, detection of points position and verification of signal statuses protecting the particular route and in case of home signals line block status - MP1 memory;
- P2 sequence, locking up the route i.e. locking points and other signals protecting planned route against traffic hazards - MP2 memory;

- P3 sequence, setting the clear signal - MP3a memory, once the train enters the first non-occupancy control sector, after the signal lights are switched from clear to stop - MP3b memory, but route locking progresses.
- P4 sequence, the lock releases automatically (or manually in case of failure) once the train passes the fouling point or the beginning of last crossover in planned route - MP4 memory.

In order to assure traffic safety the line block is employed, which is supposed to prevent two trains coming from different directions from entering the same track or two trains travelling up the same track from running into each other. The sequences the line block operates to determine traffic direction are presented in fig. 3

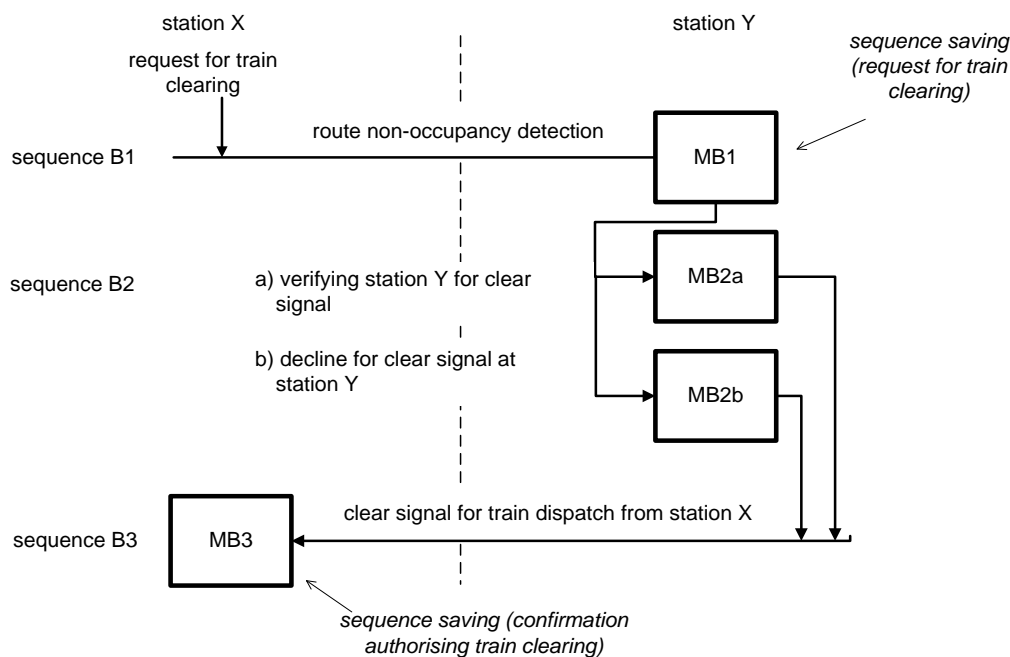

Fig. 3. The sequences line block operates to determine traffic direction

Station X requests station Y to grant approval for train dispatch i.e. to occupy that specific route - B1 sequence. Station Y verifies (B2 sequence) whether signal gives the clear signal to occupy the given railway - MB2a sequence memory. Then the possibility of opening that route to traffic has to be ruled out - MB2b sequence memory. Station Y gives station X clearance to enter given track - B3 sequence.

Going up specific railway in the wrong direction should be prevented by similar solutions assuring safety of the traffic.

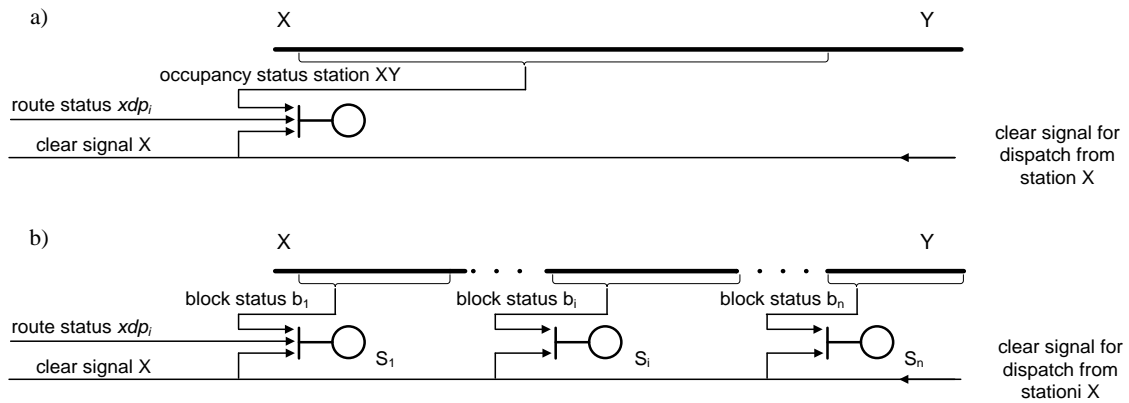

Fig. 4. Diagram showing safety procedure applying to wrong-way driving

Preventing train from running into back of another train going in the same direction employs the basic traffic safety rule i.e. one train per block section. fig. 4a illustrates a train driving at station's-distance (e.g. semi-automatic line block system), fig. 4b illustrates route divided into block sections (automatic line block system).

Train traffic control systems have to be safe. This means robustness and resilience to disturbance and damage which potentially could pose danger to traffic safety.

Information flow involved in executing those algorithms is shown graphically in fig. 5. Mother nodes of the graph are objects: control room ND1, displacement d_i , points z_n , neighbouring control room ND2, signal S_j and vehicle p_k . Arms of the graph are: reported statuses of particular objects - X, and control signals Y for those objects.

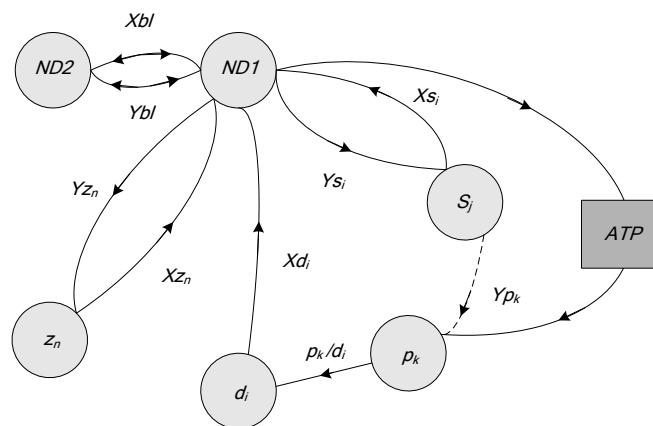

Fig. 5. Information flow in the process of controlling train traffic including the ATP system.

Classic train traffic management (TTM) systems assure safe route preparation. Their primary function is to give the clear signal. From there the safety of the train rests on hands of train driver because it is his responsibility to correctly interpret TTM signals and react accordingly. Hence, it is only when the ATP system is introduced train traffic becomes safe regardless of actions undertaken by the human i.e. train driver.

The train traffic control graph (fig. 5) includes the automatic train protection (ATP) system illustrated as a rectangle. The ATP system transmits information received from the Integrated Control Room (the TTM system) directly to the vehicle. The train driver has no influence on the process. The ATP system automatically processes that information and assures traffic safety through automatic speed limiter slowing the vehicle down once its speed exceeds safe levels.

The TTM systems have been used in train applications for a long time. The ATP systems are normally employed for train speeds reaching 120 - 160 km/h and more, and for high-volume traffic, especially in underground systems.

Hence the ATP system can be classified as a train traffic control subsystem or - due to its primary function involving safe train management - independent system. This system uses information sourced from TTM devices transmitted via purpose-built transmission channels. Hereafter this paper concerns the ATP systems.

3. Automatic Train Protection ATP

3.1. Operating principle

The automatic train protection systems are introduced to railway networks in order to increase traffic safety by replacing the train driver - eliminating the human factor. The technology is employed to take notice of signals, make train-driving decisions and automatically cut-off drive and apply service or emergency brakes. The train traffic management (TTM) system allows the traffic controller to safely manage traffic over given area, whereas the ATP system assures train safety, by supporting the train driver through overlooking and correcting his inputs accordingly [2, 3, 4, 5, 7]. The automatic train protection ATP system is a system fundamental for train safety and is the basic subsystem of train traffic control systems e.g.: ATC = Automatic Train Control (including ATO - Automatic Train Operation), ETCS - European Train Control System, and ERTMS - European Rail Traffic Management System.

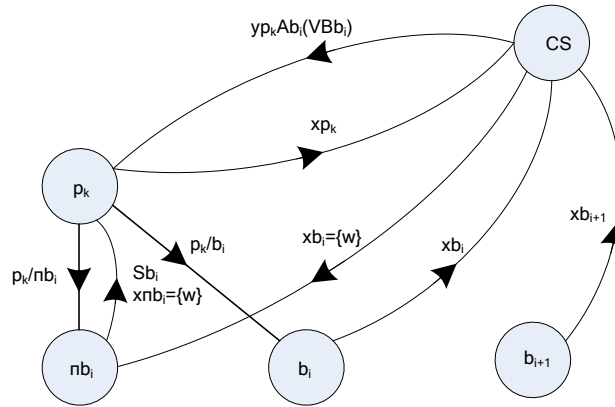

Fig. 6. Information flow graph for train control process

The process of driving train involves Integrated Control Room (e.g. signal box), which gathers information on railway non-occupancy of block section xb_i , processes it and transmits to the train p_k . Time-invariant information is passed on at the beginning of the route πb_i and time-varying information (e.g. currently shown signal) passes over a dedicated transmission channel. This process is graphically illustrated in fig. 6. Mother nodes represent the vehicle p_k , block section b_i , initiation point πb_i , next block section b_{i+1} and Integrated Control Room ICR . The graph shows the train reaching the initiation point ($p_k/\pi b_i$ arm – straight line) and train movement through the subsequent block section (arm p_k/b_i also a straight line). The Integrated Control Room ICR receives information on statuses of block sections and vehicles (arched arms xb_i , xb_{i+1} , and xp_k). The information xb_i is sent from the Integrated Control Room to the initiation point πb_i and next to the train p_k to activate it. Also transmitted from the Integrated Control Room is the control program y to train p_k activated with A at distance b_i , (arm yp_kAb_i), which is a function of safe speed VBb_i .

The ATP system operates based on information sourced from: track-side equipment and the vehicle. Data exchange between the rail and train takes place via a transmission channel which regardless of needs and solutions enables either one-way data feed (rail-train) or two-way data feed (rail-train-rail).

The ATP system has to meet the conditions in order to assure safety:

1. Information from TTM equipment should only be processed by the relevant train.
2. The actual speed of train over given block section mustn't exceed the safe speed.

For the above-mentioned functions to be executed correctly, information sourced from track-side equipment has to target a particular train. Train's ability to acquire that information will be hereinafter referred to as train activation. Activation is live only over a specific distance normally equal to the block section.

The ATP system protects train by comparing real-time (at each point of the route) train speed $VR(s,t)$ with current value of safe speed $VB(s,t)$. In authors' opinion, in any other case when the system does not operate in real-time, it cannot be classified as an ATP system. A system with those functionalities can then be perceived as a train driving aid, because the ATP system is beyond all designed to keep speed of the train within the pre-defined speed profile.

$$VR(s,t) \leq VB(s,t) \quad (1)$$

Once the true speed $VR(s,t)$ exceeds the safe speed $VB(s,t)$ brakes are engaged automatically. The system generates step responses by automatically disengaging propulsion at speed $VB(s,t) - C1$, and automatically applying service brake at speed $VB(s,t) - C2$ ($C1, C2$ assumed values of speed hysteresis $C1 > C2$). If despite applying the service brake, the true speed $VR(s,t)$ exceeded the safe speed $VB(s,t)$, then the emergency brake is applied.

The ATP system executes those functions in line with traffic safety guidelines (one train per block section), in the following manner:

- information containing the size (parameter) of block section b_i is transferred to the train within that block section,
- the information received within block section b_i can be implemented only by the train it was intended for.

The ATP system operates based on received information and current procedures, fig. 7 shows that sequence. The ATP system operates in back-to-back, cyclically repeated at each block section sequences:

- T0 sequence - train p_k enters block section b_i , rail-train data exchange possible;
- T1 sequence - activation A of train p_k at block section $b_i - p_kAb_i$, i.e. ensuring the intended train is the sole recipient of given information;
- T2 sequence - achieving the safe speed VB , factoring in activation, information gathered from rail and train parameters;
- T3 sequence - real-time monitoring true speed VR against safe speed VB ;
- T4 sequence - controlling the drive and brake system in line with monitoring findings from the previous sequence.

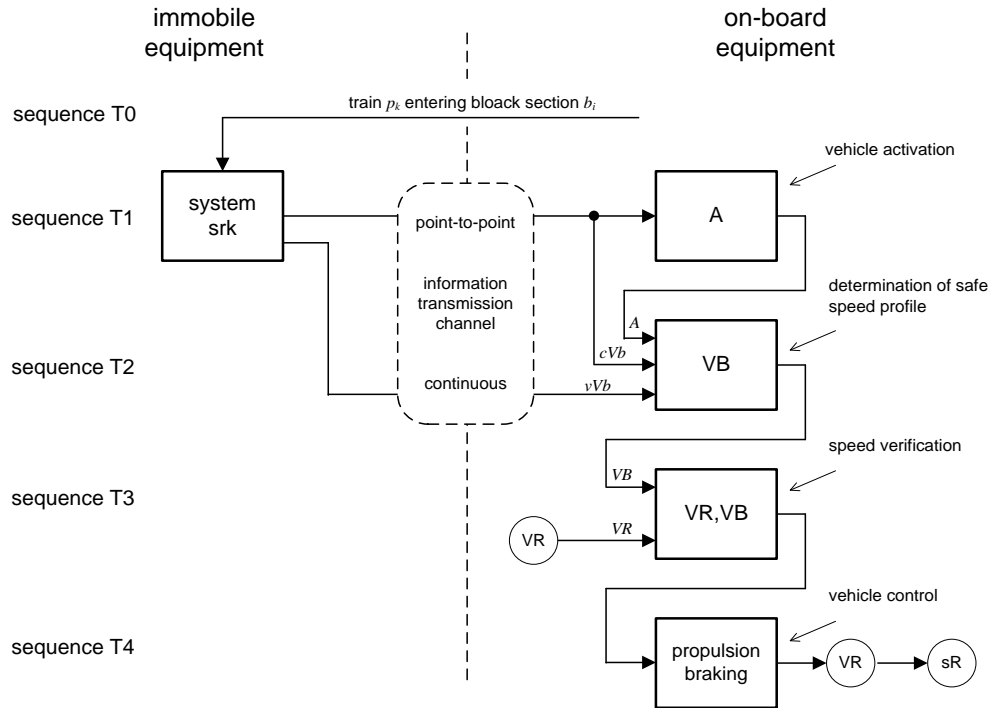

Fig. 7. ATP system operation upon entering next block section

Based on the aforementioned, an ATP system should incorporate the following elements (systems):

- track-side equipment preparing information for the vehicle;
- transmission channel facilitating data exchange between track-side equipment and vehicle;
- activation system allowing correct interpretation of received information;
- systems maintaining safe speed, including both track-side and vehicle equipment;
- actual speed and displacement monitoring system;
- system monitoring actual speed against safe speed; propulsion and brakes control system.

3.2. Source of information for ATP

ATP system uses information sourced from parameters of block section and the vehicle. Parameters of block section are dictated by rail infrastructure and traffic status. Constant parameters of block section Cb_i are: name b_i , block section length Sb_i , block section origin $g\pi b_i$ (required to determine covered distance) and constant speed (permitted) cVb_{ij} , determined by original parameters of the track (curves, gradient) and their origins' coordinates $gcVb_{ij}$. For purposes of clear communication with the vehicle those quantities

(parameters) have been expressed with words. Hence, constant information about the block section consists of three words and the information about the permitted speed consists of two words. Information about constant parameters of block section can be presented in form of sets:

$$Cb_i(s) = (b_i, Sb_i, g\pi b_i) \cup \sum_{j=1}^{j=m} (cVb_{ij}, gcVb_{ij}) \quad (2)$$

Assuming there are normally 2-3 permitted speed changes per block section i.e. $m=2...3$, the information about constant parameters of block section consists of seven to nine words. Constant parameters also depend on the technical condition of rail. For instance temporary speed limit. Also often fed down the communication channels is information on rail gradient.

The time-varying parameter of block section, determined by traffic status of particular block section b_i is railway non-occupancy xb_i and points position xz_n including the next block section status xb_{i+1} . The vehicle speed limit is denoted by $vVb_i(t)$. This parameter can take different values of vehicle speed limit, for PKP (the E1 provision) there are 17 different signals concerning the vehicle speed limits imposed on particular block section b_i and warning about speed at the next block section b_{i+1} . Therefore, the information about variable parameter of the block section i.e. the vehicle speed limit is conveyed by a single word, which can assume n values, e.g. for PKP $n = 17$.

In certain cases e.g. for activation of train p_k at distance b_i , an information is required at the initiation point πb_i about railway non-occupancy at given section - hereinafter referred to as $x\pi b_i$.

Parameters of the vehicle are top speed V_k , deceleration ah and true speed VR . Table 1 gives fixed and variable (time-varying) parameters of rail and vehicle.

Table 1

Parameters of rail and vehicle

	Parameters of	
	block section - distance	vehicle
fixed	distance Sb_i starting point πb_i permitted speed (constance) $cVb_{ij}(s)$ (including temporary speed limits)	top speed V_k deceleration ah
variable	railway non-occupancy xb_i points position xz_n vehicle speed limit $vVb_i(t)$ safe speed $VB(s,t)$ – point 3.3	true speed $VR(s,t)$

Bearing in mind above distinction between parameters describing displacement (block section) i.e. time-varying and time-invariant, it is justified to assume fixed quantities (parameters) have to be communicated prior to block section b_i . Time-varying quantities (parameters) have to be fed continuously, once the vehicle is within the block section b_i .

ATO (Automatic Train Operation) systems could increase amount of data transmitted through communication channel railway - vehicle.

3.3. Safe speed curve

Safe speed of the vehicle $VB(s,t)$ at each point in time and route depends of constant parameters of railway and vehicle, including traffic status. Traffic situation is time-varying and depends on trains' locations prior to entering analysed section and is given as vehicle speed limit $vV(t)$. Parameters of the vehicle influencing safe speed are: top speed Vk , deceleration ah . Safe speed of vehicle is defined as the lowest of above velocities (in fig. 8 solid thick line):

$$VB(s,t) = \min(cV(s), vV(t), Vk) \quad (3)$$

Also referred to sometimes is the safe route speed $Vd(s, t)$, which takes smaller of the quantities $cV(s)$ and $vV(t)$. In that case the safe speed of vehicle is determined as $VB(s,t) = \min(Vd(s,t), Vk)$. Safe speed $VB(s, t)$ is usually defined as speed curve (speed profile) as a function of displacement. Safe speed curve might be given by either step curve or solid line curve.

To determine safe speed curve as a function of displacement, the following constant parameters have to be known: displacement Sb_i block section b_i , permitted speed $cV(s)$ (depending on curve radius, gradient etc.) and vehicle's top speed Vk . Plotted onto the chart have to be time-varying speed $vV(t)$, depending on traffic status ahead of the vehicle.

a) safe speed and its components

b) safe speed at different permitted speeds $vV_1(t) > vV_2(t) > vV_3(t)$ 

Fig. 8. Charts of safe speed as a function of displacement

In fig. 8a shown are direct component $cVb_i(s)$ and V_k (thin solid lines), member variable $vVb_i(t)$ (dotted line) and safe speed curve $VB(s, t)$ (thick solid line). Fig. 8 shows safe speed curve $VB(s, t)$ adjusted for deceleration ah for 3 different member variables of speed. $vV_1(t)$ – clear signal for entering the next block section, components $vV_2(t)$ and $vV_3(t)$ bring the train to a halt by the end of block section.

The location for determining safe speed curve depends predominantly on assumed data feed method. Bearing in mind the above and gathered experiences, the seemingly most natural solution is feed constant parameters of route as a set of $Cb_i(s)$ and perhaps current block section status at its starting point – $x\pi b_i$. Variable parameters of the route defined as $\{vVb_i, gvVb_i\}$ have to be fed continuously via adequate transmission channels. Henceforth, the safe speed VB will be referred to as the final speed, without mentioning its components.

4. ATP System – Overview

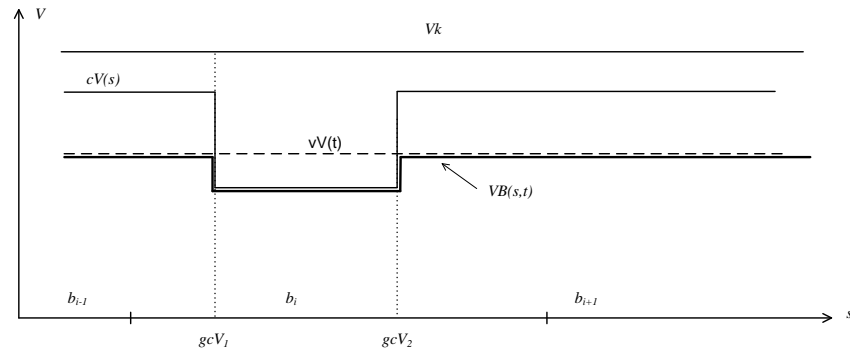
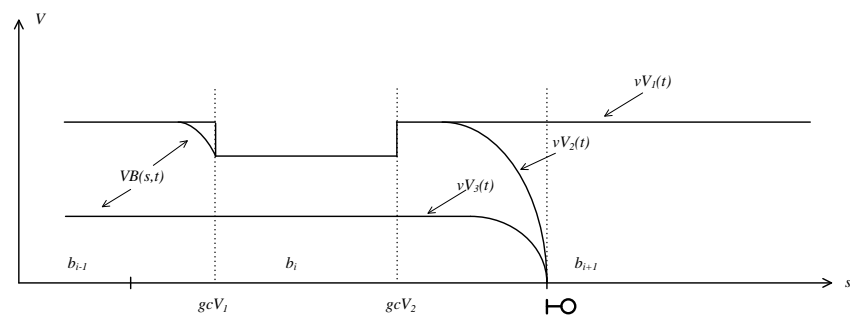
The general operating principle of automatic train protection ATP has been presented as an information flow diagram. Its nodes are: fundamental components of ATP, i.e. safe speed VB block, vehicle activation A block and auxiliary systems: measuring travelled distance sR , drive and brake regulator RNH with equipment controlling drive and brakes NH . The mother node is the beginning of block section πb_i , which feeds information about constant parameters of block section and railway non-occupancy status of block section $x\pi b_i = \{w\}$. The other mother nodes are b_i , which feeds data about member variable $vVb_i(t)$ and information about parameters (V_k , ah , VR) of vehicle Pp_k . Information on status of given node transferred to another node are the graph edges.

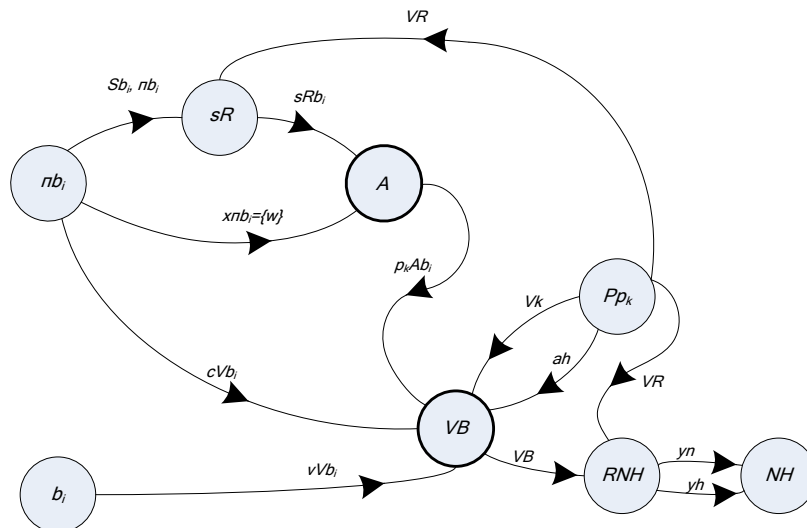

Fig. 9. Information flow diagram for ATP system

From perspective of assuring safe speed two alternatives were considered for ATP: default option - on-board equipment, and track-side equipment. Also, a combination of the two could be considered.

The amount of information fed from track-side to the vehicle relies on implemented ATP system option, especially:

- train activation (grating authorisation to receive data),
- location from which safe speed is assured.

The structure of data feed depends on its character (time-varying or time-invariant).

Train activation i.e. authorising the train to receive information about safe speed within given block section, requires feeding to the train identification of block section, its coordinates and length and starting measuring distance to cover throughout the block. This is theoretically possible only when the train is assigned a number which was relayed to the

Integrated Control Room. In practical terms - when pursuing traffic safety by limiting train per block number to one - it is enough to send coordinates of start-of-block section and block length to the train when and only when that particular block section is non-occupied. This means at point πb_i an information set has to be sent to the train, namely $\{Sb_i, g\pi b_i\}$ and $x\pi b_i = \{w\}$.

Activation A of train p_k launched at block b_i should only be carried out through on-board equipment and the train should be marked as $p_k Ab_i$. One should also consider activating the train from track-side equipment and feeding the information $p_k Ab_i$ to the train. In that instance, however, in order to engage measurement of real distance sRb_i travelled over block b_i , the start-of-block section $g\pi b_i$ coordinate is required.

The safe speed i.e. the parameter key for train safety depends on parameters of track and vehicle as well as the traffic situation. It could be determined as the item 3.3 shows. The options available for determining it are on-board, track-side equipment or partially on-board and partially by track-side equipment. To determine the safe speed curve the following are required:

- pool of data on permitted speed $\{cVb_{ij}, gVb_{ij}\}$ - that information can be fed point-to-point or at the start-of-block section;
- member variable $vVb_i(t)$, i.e. the vehicle speed limit determining the traffic status ahead of the train within block section b_i and within the following b_{i+1} , should be fed continuously in order to provide the ATP system with current information about the traffic situation.

On-board option. Specification of the railway (item 3.3) given as set of member constant speeds and their coordinates $\sum_{j=1}^{j=m} (cVb_{ij}, gVb_{ij})$ are fed to the vehicle at the starting point of block section πb_i . Time-varying traffic status $vVb_i(t)$ should be transmitted to the vehicle continuously throughout the block section. On-board, that information would have been completed by constant parameters of the vehicle: top speed V_k and deceleration $ah(v)$. Should the train p_k be activated at the block section $b_i - p_k Ab_i$ - then safe speed $VB(s, t)$ is determined, which defines what is the speed the train can carry in order to assure traffic safety. If the train is not activated, its safe speed equals to naught - $VB = 0$. fig. 10 shows a safe speed block $VB - VB$ curve only; no members. In order for the on-board safe speed equipment to function necessary are measurements of real distance sRb_i travelled by the train over given block section.

Safe speed being determined on-board the vehicle seems to most neutral solution. The operating procedure engages once the train receives information from track-side and is completed by on-board data. Data transmission might be unidirectional. The fixed channel feeds a single word $vVb_i(t)$, which could represent several values (item 3.3).

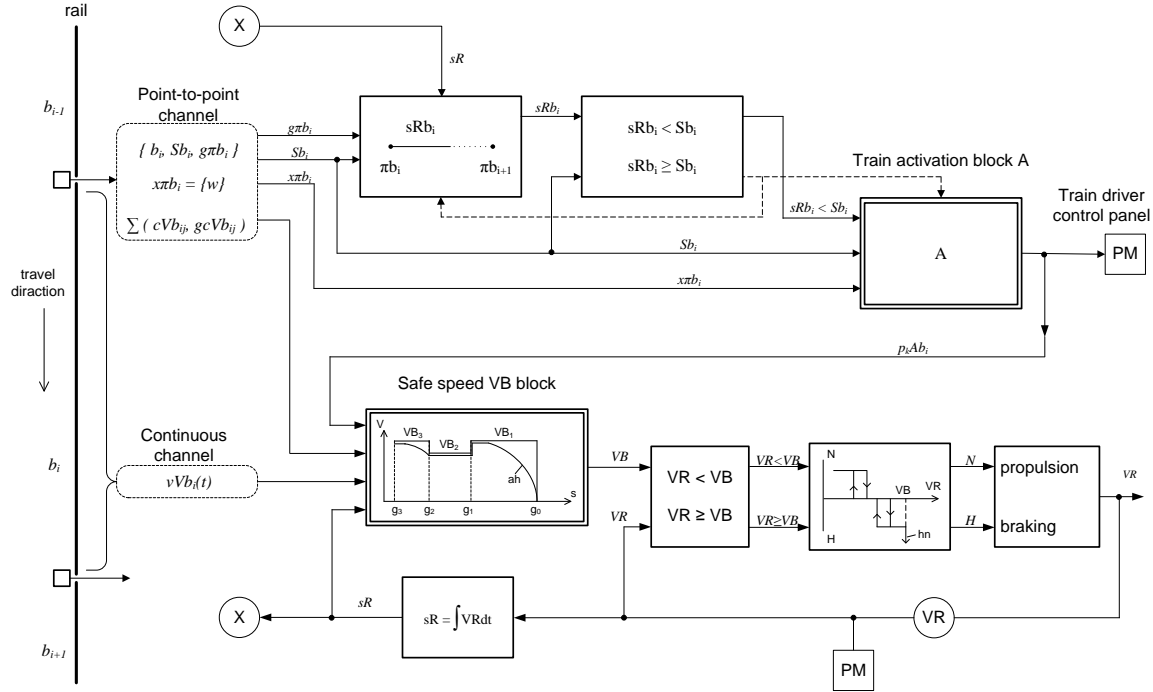

Fig. 10. Block diagram of ATP system, on-board option of determining systems VB .

Established safe speed $VB(s,t)$ is passed onto the system comparing the true speed $VR(s,t)$ with the safe speed $VB(s,t)$ and according to selected algorithm it controls: disengagement of drive, service brake application or emergency braking.

Track-side option. fig. 11 shows how safe speed is determined. The safe speed block, located in track-side equipment is provided with a set of member constant speeds and their coordinates $\sum_{j=1}^{j=m} (cVb_{ij}, gVb_{ij})$ and member variable speeds $vVb_i(t)$. Constant parameters of

the vehicle have to be fed from the vehicle to track-side equipment at starting point of the block section πb_i : top speed V_k and deceleration $ah(v)$. The real distance sR travelled by the train over block section b_i has to be continuously fed from vehicle to the track. The distance sR is necessary to determine safe speed $VB(s,t)$, similarly to the on-board option, however, in that case no transmission channel was required.

Hence, the vehicle has to be continuously provided with safe speed $VB(s,t)$ which is determined by track-side equipment is consists of multiple words conveying different values. $VB = \{VB(s,t), gVB(s,t)\}$

Data transmission in track-side option, both point-to-point and continuous has to be bi-directional. Furthermore the vehicle has to use systems allowing to carry safe speed $VB(s,t)$ only when the train is activated p_kAb_i . Also worth considering are solutions, where vehicle activation signal is passed from a particular point train-to-track. When going over starting

point of block b_i first information fed is the activation signal p_k and once the train is activated $p_k Ab_i$ information from on-board to track-side equipment is transmitted at the very same point. In that case, time-related transmission difficulties might arise at the starting point should the train move at considerable speed.

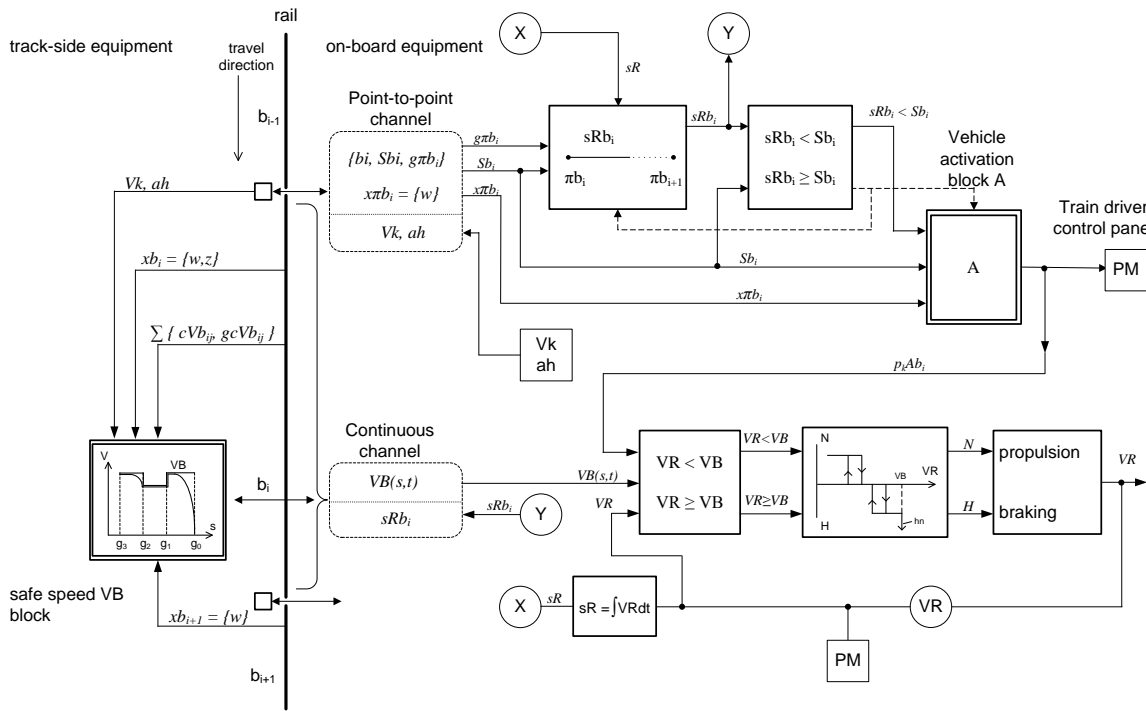

Fig. 11. Functional diagram of ATP system. The track-side option

Combined option. Here, two systems determining safe speed are considered: track-side and on-board. The track-side system determines the part of safe route speed depending on direct component (permitted speed) and variable component (vehicle speed limit). In this case it is necessary to maintain a constant feed between vehicle and railway about the real distance sR travelled by the train. Safe speed is then computed on-board the vehicle based on constant parameters of the vehicle: top speed V_k , deceleration $ah(v)$ and linking it with train activation. Bearing in mind the above mentioned, this option resembles the track-side option.

Provided these deliberations, the on-board option of safe speed $VB(s, t)$ system should be acknowledged as the most rational. It relies on on-board safe speed system, where data transmission is unidirectional: set of direct variables $\sum_{j=1}^{j=m} (cVb_{ij}, gcVb_{ij})$ is fed point-to-point and one-word member variable $vVb_i(t)$ is transmitted continuously. The concept of ATP safety system [11] is presented in [7].

5. ATP Transmission Channels

5.1. Track-to-train rail and wire transmission channel and railway non-occupancy check

Transmission in rails is the oldest continuous transmission system feeding data from track to train. It uses an insulated rail section, being at the same time the centrepiece circuit element. The train rail has undergone substantial structural changes over the years and mechanical parameters of modern rail enable trains to develop speeds of up to 350 km/h and more. The insulation separating one rail from another has also considerably evolved. Due to changes in mechanical and electric parameters of rails, transmission in rail found application in high speed railway, among other in Japan and France.

In track-to-train transmission data is fed through magnetic coupling of receiving antenna with rail which carries electric current modulated by information-conveying signal. Parameters of coded track signals are determined to a great extent by parameters of insulated section.

Traditional train rails (25-30 m long) are normally joined up using rail joints fitted to sleepers - usually wooden - set on ballast. Main disadvantages of transmission in rail using transitional rails are: too thin layer of ballast and its littering; often failing insulated rail joint usually due to insufficiently hardened rail track support, double sleepers rest on; raising longitudinal impedance of rails using standard rail bonds; necessity to use impedance bonds for electric traction; inefficient water drainage from trackage.

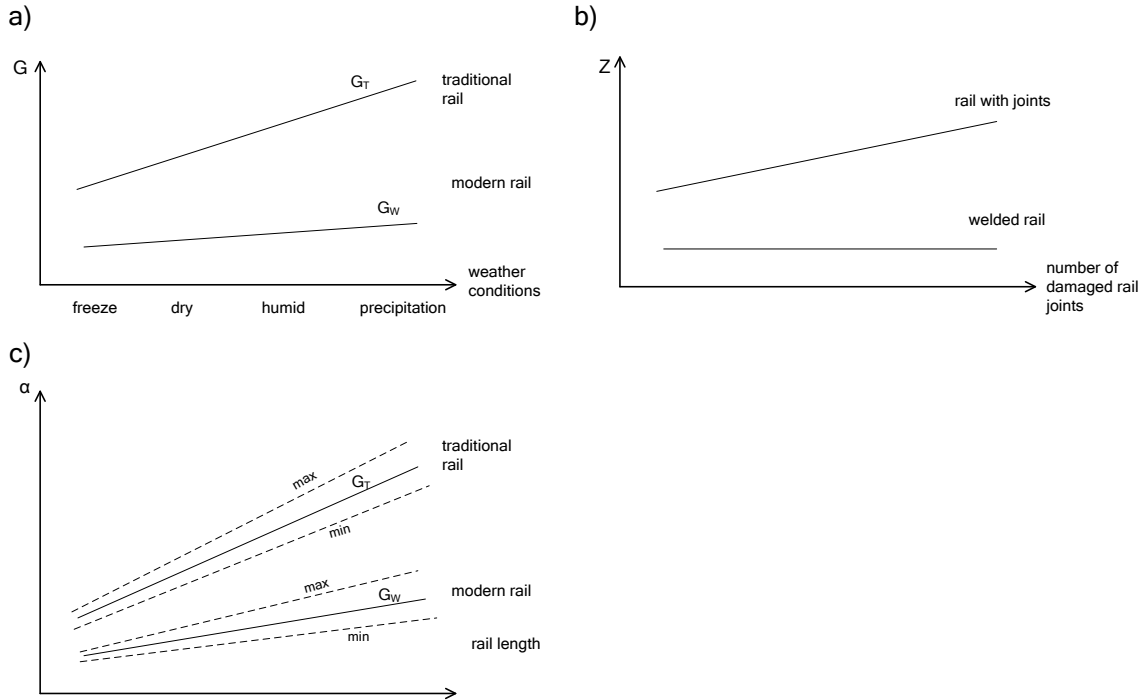

Fig. 12. Chart showing fluctuation of conductance G , rail impedance Z and attenuation α in both traditional and modern rail.

Modern train track uses two rail lines of welded rails, fixed to concrete sleepers (optionally hard wood), resting on ballast at least 30 - 35 cm thick (UIC recommendation [6, 12]). Water drainage from trackage has to be in place as well. Introduction of requirement for main lines to have certain thickness ballast meant lower conductance G in modern rail compared to traditional rail $G_W < G_T$, and its lower fluctuation depending on weather conditions (fig. 12a).

Welded rails - eliminating rail joints - maintain constant longitudinal impedance whilst in traditional rails it fluctuates, when consecutive rail joints fail (fig. 12b).

The quantity characterising transmission from transmitter to receiver is attenuation α , which depends on specific attenuation and circuit length. Specific attenuation is determined predominantly by specific conductance G (fig. 12a) of track circuit and longitudinal impedance Z (fig. 12b). Given the $G \gg \omega C$ influence of specific capacitance can be ignored we get the formula for attenuation.

$$\alpha = \sqrt{\frac{1}{2} G \cdot \left(R + \sqrt{R^2 + \omega^2 L^2} \right)} \quad (4)$$

fig. 12c compares fluctuations of signal attenuation along track for both traditional and modern rails.

The modern rail track uses electrical separation to insulate rails as opposed to traditional tracks using insulating spacers, which evade mechanical continuity of the rail. Similarly to the rail itself, electrical separation has also gone through multiple stages of development (different solutions). At the current time, the most popular solutions assume that reach of neighbouring track circuits is determined by voltage resonance circuits chirping signals of frequencies used in neighbouring circuits. The circuits overlap creating an electrical separation system (fig. 13). The transmitter and receiver of neighbouring circuits are confined between voltage resonance systems, determining limits of neighbouring circuits.

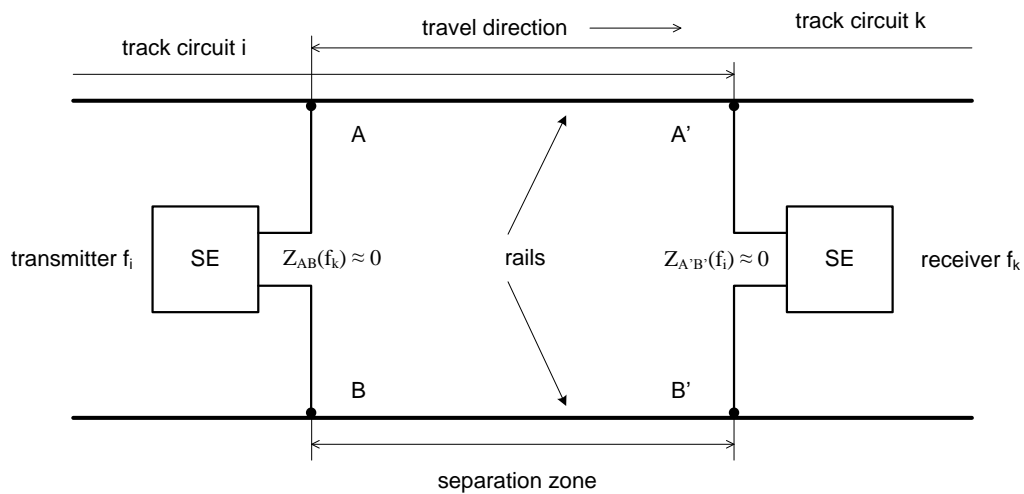

SE - electrical separation
 f_i, f_k – signal frequencies generated by transmitter and receiver of track circuits i and k

Fig. 13. Block diagram of electrical separation system

Another ever-popular railway non-occupancy controlling solution is counting axes entering and exiting controlled section (block). To facilitate this procedure, employed are two sensors c1 and c2 situated next to the rail in sequence (fig. 14). This arrangement enables measuring speed of moving rolling stock. In order to improve safety of equipment detecting railway non-occupancy an identical set of sensors c1' and c2' should be fitted to the second line of rails.

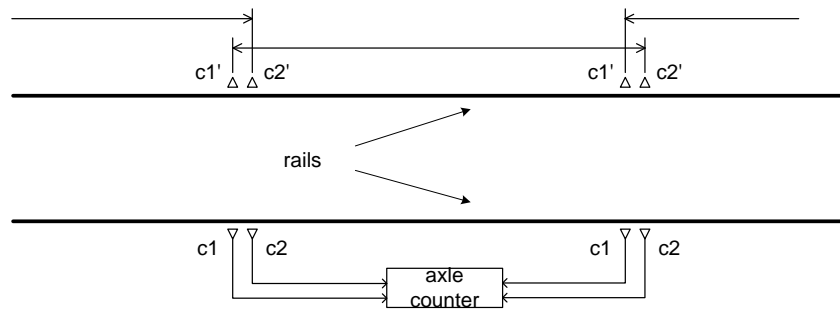

Fig. 14 Arrangement of sensors detecting axes at controlled track section

Main disadvantage of controlling railway non-occupancy by sensors and axle counters - as opposed to track circuit - is complete departure from the subject controlled i.e. rail track construction. Theoretically and practically, once the axle counter deems the rail section non-occupied, one could "cut-out" said segment and equipment would allow further movement. This runs counter to the general notion of safe travel along non-occupied track.

In the context of ATP systems discussed in this paper, an important feature of track circuit is its double functionality: to control railway non-occupancy and to transmit data track-to-train - the rail plays the role of signal-launching antenna. However, using track circuits to feed data requires using more complex electrical separation systems compared to non-occupancy detection. Another feasible solution is employing for data transmission track circuit, and leaving railway non-occupancy to e.g. axle counters. The advantage of this solution is simplification of electrical separation system, whereas rail continuity is controlled by the transmission system (something axle counters cannot do). The downside is it requires expanding the track-side infrastructure.

In ATP systems using transmission in track, track circuit signal is received only by the first train, whose receiving antennas have to be located ahead of vehicle's first axle. Every other train running on the same track circuit is not capable to receive signal, since the first axle of the first train short-circuits rails carrying electric current. Hence, train activation is not required.

Electric signal in track circuit is prone to disturbance, primarily caused by traction electricity. In order to protect ATP signal against broadly defined disturbances, different carrier frequencies are used for neighbouring track circuits. Also used could be code reading elements.

Sent via the track circuit is also time-varying information i.e. concerning traffic situation. Information such as permitted speed determined by constant parameter of the track - $cV(s)$ should be sent point-to-point e.g. by using balise (beacons) or short wire loop (e.g. Japan, France).

Wired transmission channel. Another type of transmission channel closely linked to rail tracks is the wired transmission channel. It is constructed by laying transmission lines along the rail. The cable can run both symmetrically and asymmetrically to the track's longitudinal axis. It can be long enough to encompass up to several block sections. In common solutions, the wire is used by non-occupancy detection through track circuits and axle counters. Data is fed continuously, once the receiving antenna beneath the train car gets over transmission line.

The main advantage of wired transmission channel are substantially better electric parameters (including attenuation) compared to track circuit. Hence the carrier frequency of the signal is over a dozen greater than that used in track-to-train transmission, thus transmission is resilient to disturbance from harmonics of return traction current. Therefore, much more information could be sent and bi-directional transmission could be used.

Wired circuits are characterised by:

- using additional element, cable in rail. In open spaces this cable is exposed to damage and theft; thus is normally used in closed spaces, e.g. in the underground.
- compulsory train activation, preventing unauthorised trains from receiving and exercising the signal,
- low signal attenuation, enabling carrier frequencies of several dozen kHz and more; these frequencies are beyond the band of biggest disturbance caused by return traction current; allowing to send data in amounts sufficient for ATP and ATO uses;
- bi-directional data transmission.

Wired transmission channel due to its positioning - either in or next to the track - could be perceived as improved track transmission channel holding significantly better electric parameters.

5.2. Point-to-point and radio transmission channels

Systems employing point-to-point transmission channels, at key locations of railway lines, mainly before signals, the so-called balises (beacons) are in place facilitating track-to-train data exchange. Point-to-point data exchange takes place when the vehicle balise is over track balise. The main disadvantage of this transmission channel is the up-to-dateness of information only at the transmission point. On-board information update take place every time period $\tau = \frac{Sb_i}{V}$, depending on distance between balises and train speeds, e.g. at

block sections 1 km long and train speed 120 km/h $\tau = 30$ s. This is irrelevant when feeding constant information. It seems as if this is the best transmission channel for that purpose. In case of variable information, however, out-of-date information could cause operational issues, and in some cases could cause safety hazards. Two problems then arise: changing the signal, when the train is between balises and stopping precision relative to the beacon.

Under train traffic conditions (high weight and high speed) precisely braking the train before the balise could be an issue. At the stop signal, trains due to their braking curves computed with safety margins, would normally stop in substantial distance before the balise. In order to resume travel once the clear signal is given, train driver has to press a button for 20 km/h drive up to the balise, so that once it receives the clearing signal the travel is resumed. Also, the stop signal changes into clear signal when the train is moving, the clear signal would be received only at the next balise. Hence, the ATP would engage train brakes despite train driver seeing the clear signal. This is a common case scenario in day-to-day operation.

Far more serious consequences to traffic safety has change of clear signal to stop signal. In that case, regardless of train driver seeing the red light, the ATP system allows resuming movement up to the next balise ahead. Then, traffic safety relies solely on train driver's perceptiveness. This is an occurrence rare enough, but the hazard it poses of train safety is substantial.

Increasing the number of beacons by at least one per block section is already an improvement on point-to-point data feed drawbacks. Point-to-point transmission channel - having long history - are currently used more in other transmission systems (e.g. radio). They are key systems at low-density traffic lines.

Radio transmission. Data exchange between Integrated Control Room ICR and vehicle via radio requires two data feed channels.

- point-to-point channel - balise located at the beginning or before beginning (only just before signal) of each block section;
- continuous data transmission channel feeding information of current traffic situation at given block section.

Point-to-point channel (balise) should send information necessary to activate passing train i.e. ID, length and coordinates of start-of-block section in order to determine the distance activation remains live and status of block section at its beginning. To determine the safe speed profile a set of member speeds and their coordinates $\sum_{j=1}^{j=m} (cVb_{ij}, gcVb_{ij})$ have

to be sent over. Where appropriate, also transmitted are parameters of radio channel via which ICR to vehicle communication takes place.

Radio transmission channel which assures continuous data exchange is transmitted from ICR to vehicle p_k member variable safe speed $vVb_i(t)$, which varies depends on traffic situation ahead of the train.

Radio signal can only cover a limited area, where railways and trains run. Thus it is not tied down to particular rail section - block section. Because its carrier frequency falls within GSM band (e.g. 900 MHz) it is practically unaffected by disturbance caused by return traction current. Railway non-occupancy detection is exercised using track circuits, axle counters or through detecting train position on the track, within so-called mobile block section.

In order to maximise railway line capacity, train localization should be carried out with great precision. Railway non-occupancy detection through track circuit or axle counters, determines train position with precision reaching length of controlled section of track. Should the precision be increased, it would require short railway sections which in turn would increase infrastructure outlays. Hence this setup is only found on underground lines. The outcome of developing ETCS to use downlink feeding location of train front was introduction of so-called mobile block section, moving along with passing train. This solution requires the entire train's length to be controlled for position of its rear to be known. Information on travelled distance enables continuous feed of current train position to the Integrated Control Room - ICR. Based on that data, ICR clears other vehicles occupying particular track. Naturally, as far as safety in general is concerned (one train per given rail track - block section) it is only possible when only vehicle kitted out with this equipment are allowed to occupy that particular railway or the line is equipped with railway non-occupancy detecting devices.

5.3. Classification and properties of ATP systems

ATP systems used for trains and underground, including their latest incarnations could be classified according to numerous criteria. The most important one is up-to-dateness of data trains rely on. Modern systems should feed current information on a continuous basis [1, 8, 9, 10]. There are two solutions. Time-varying information fed continuously to every point on the track or in traditional solutions only to certain spots - predominantly signals.

Breakdown of ATP systems including related, more general systems starting with ERTMS were shown in fig. 15 and some properties of those systems were given in table 2.

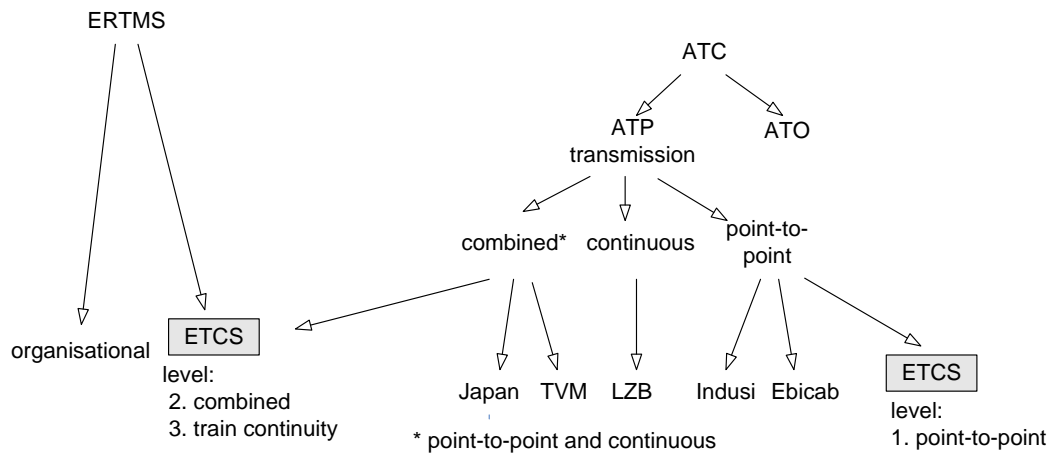

Fig. 15. ATP systems within ERTMS and ATC systems

Key role of automatic train protection ATP is to assure at each point of the route s and moment in time t true speed $VR(s,t)$ within safe speed profile $VB(s,t)$. In order for the ATP system to comply with those requirements it has to operate in real time. Safe speed $VB(s,t) = \min[cV(s), vV(t)]$ is the lowest of either direct component $cV(s)$ or member variable $vV(t)$ – item 1 in table 2.

The issue crucial for traffic safety is reception of the signal only by the train it was intended for - train activation. The need for it is dictated by properties of the transmission channel. Rail channel allow receiving information solely by the train first on the track-to-train transmission channel. Also the point-to-point channel, due to its dimensions feeds information only to the train whose receiving antenna passes over balise - item 2 in table 2. Item 3 table 2 gives frequency of information updates. Based on those, determined is safe speed profile controlled by the ATP system.

Item 4 table 2 gives possible methods of detecting railway non-occupancy for different transmission channels. Item 5 table 2 gives some examples of ATP system applications under different train managements, usually keeping original markings.

Table 2

Selected properties of ATP systems

No.	transmission channel	track	track and point-to-point	wired	radio and point-to-point	point-to-point
1	key functionality of ATP system	$VR(s,t) < VB(s,t)$ at $VB(s,t) = \min[cV(s), vV(t)]$				
2	train activation	neutral ¹⁾	neutral ¹⁾	additional system	additional system	neutral ¹⁾
3	data update rate	continuous always $vV(t)$ occasionally $cV(s)$	continuous $VB(s,t)$	continuous $VB(s,t)$	continuous $VB(s,t)$	VB per period τ (several dozen seconds)
4	railway non-occupancy detection	traditional track circuit and with electrical separation	track circuit with electrical separation	track circuit, axle counter	track circuit, axle counter, mobile block section	track circuit, axle counter
5	example applications	ARS metro, old train solutions	TVM 300 and 430 France TGV, Japan New Tokaido	LZB Germany high speed railway, metro	ETCS 2 level	KVB France, Ebicab Finland, ETCS 2 level

1) no additional systems required

6. Summary

Modern rail traffic control systems help the dispatcher to assure traffic safety as part of train traffic management. On the other hand, train traffic safety to the extent specified by signal observance, reading indicators, their interpretation and directly influencing propulsion and brakes, up to recently was within capacity of the train driver solely. With introduction of automatic train protection ATP, they started to take over functions and actions normally carried out by the train driver thus assuring train traffic safety.

Key functionality of the ATP system is to assure train true speed within safe speed profile depending on constant parameter of rail track and train as well as traffic situation. Therefore, ATP systems play the role of secondary safety system for managing train traffic. They operate based on information sourced from: track-side equipment and the vehicle. That information breaks down into constant, describing parameters of route and vehicle, and time-varying describing current traffic situation and train true speed. Two main subsystems are responsible for executing ATP system tasks:

- train activation i.e. authorising the train to receive information intended solely for that particular vehicle,
- maintaining safe speed, comparing it against true speed, and depending on result inspecting propulsion and brake systems.

Modern ATP systems usually use in excess of one transmission channel - point-to-point situated at the start-of-block section feeding information necessary to activate the train and member constant speed, continuous transmission channel feeding member variable safe speed depending on traffic situation ahead of the train.

Train and underground lines use ATP systems employing rail track, wired and radio transmission channels. On the other hand, ATP systems relying solely on point-to-point transmission channel can be used for low-volume lines (due to steady traffic situation) and for auxiliary channels utilised by other ATP systems.

References

1. Baranski S., Kubik S.: SOP-2P ATP system for A line, Prague underground, Conference Proceedings, Semtrak Electric Traction, Zakopane 2002.
2. Bergiel K., Karbowski H.: Automatisation of train driving, EMIPRESS Publishing House, Lodz 2005.
3. Bergiel K., Karbowski H.: Data transmission in automatic train protection systems with transmitting antenna covering many block sections, Transport Archives no 3/2006.
4. Dabrowa - Bajon M.: Basics of train traffic management, Publishing House of Warsaw University of Technology, Warsaw 2002.
5. Dyduch J., Pawlik M.: Automatic Train Operation systems. Publishing House of Radom University of Technology, Radom 2002.
6. Karbowski H.: Data feed channels used by automatic train protection ATP systems, Telecommunication and Traffic Management 2/2009, EMIPRESS Publishing House, Lodz 2009.
7. Karbowski H., Baranski S.: Traffic safety in transport, Monographs of Technical University of Lodz, Lodz 2011.
8. Karbowski H., Baranski S.: New functionalities of data transmission system via track cables employing digital SPI-P, phase modulation, Trains Digest 2/1993.
9. Karbowski H., Baranski S., Kubik S.: Automatic train protection - AOP (ATP) used in Warsaw underground and A line, Prague, Conference Proceedings, "Transport of the XXI century", Warsaw University of Technology, Faculty of Transport, Warsaw 2001.
10. Lehr S., Naumann T., Schittenhelm O.: Parallele Ausrüstung der Strecke Berlin-Halle/Leipzig, Signal+Draht 4/2006.
11. Wawrzynski W.: Safety of control systems in transport, Publishing House of Institute for Sustainable Technologies, Warsaw - Radom 2004.
12. Technical standards Vol. 6 - detailed technical conditions for modernising and building train lines of up to 200km/h (conventional rolling stock) and 250 km/h (for tilting rolling stock), passed for implementation by the Resolution no 263/2010 Board of Directors presiding over Polish State Railways SA, 14 June, 2010.