



Article citation info:

Śliż P, Wycinka E. Identification of factors that differentiate motor vehicles that have experienced wear or failure of brake system components during the warranty service period. *Eksploracja i Niezawodność – Maintenance and Reliability* 2021; 23 (3): 430–442, <http://doi.org/10.17531/ein.2021.3.4>.

Identification of factors that differentiate motor vehicles that have experienced wear or failure of brake system components during the warranty service period

Indexed by:



Piotr Śliż^{a,*}, Ewa Wycinka^b

^aKatedra Organizacji i Zarządzania, Wydział Zarządzania, Uniwersytet Gdański, ul. Armii Krajowej 101, 81-824 Sopot

^bDepartment of Statistics, Faculty of Management, University of Gdansk, Armii Krajowej 101, 81-824 Sopot

Highlights

- The study was carried out on a complete sample of 295 warranty repairs of X and Y brand vehicles
- The study reproduced the actual process of diagnosis and repair of the brake system
- An analysis of the operation process was carried out using the process mining method
- The identified factors that differentiate the course of brake disc wear and failure were vehicle type, body type, vehicle make, and vehicle model.
- Groups of factors that differentiate the vehicles reported for brake system failure and wear were identified.

Abstract

The paper focuses on issues related to selected automotive brakes with the aim of applying the proposed methodology to other structural systems of this type. The main aim of the paper is to identify the factors that differentiate the course of wear and occurrence of a fault in brake system components of passenger cars and light commercial vehicles during the warranty service period. The following methods were used in this study: systematic literature review, process analysis, and descriptive and inferential statistics, including analysis of variance and multiple classification analysis. As a result of an analysis of 295 brake system repairs, six differentiating factors that allowed for ex post analysis of the repairs were identified. An analysis of the interaction of these factors made it possible to distinguish three groups of motor vehicles depending on the cause of failure of the braking system. Based on the data generated in the warranty process, it is possible to determine the factors that differentiate the occurrence of a fault and the course of brake disc and pad wear.

Keywords

This is an open access article under the CC BY license (<https://creativecommons.org/licenses/by/4.0/>)

failure, warranty service, passenger vehicles, commercial vehicles, brake system, brake disc, wear, brake mechanism, wear factors, wear analysis.

1. Introduction

As a result of dynamic technological and technical development, attempts are made to find material and construction solutions that have a positive and direct influence on the economic, environmental [5], design, and production aspects related to motor vehicles. They are aimed at developing solutions that reduce CO₂ emissions [12] and fuel consumption [18], and replace internal combustion engines with electric units [11, 15]. There is a noticeable trend of improving such performance parameters in motor vehicles as acceleration and maximum speed. As a result, this requires modification of current solutions and the design of new active and passive safety systems, with a clear emphasis on the design of the brake system. Assuming that the effectiveness of the brake system in motor vehicles has a significant effect on the speed of vehicles at the time of a collision and, as a result, on the consequences of the accident, this system should be indicated as one of the most important structural assemblies of vehicles [19]. According to a report on the statistics of road accidents caused by vehicle defect factors in the UK in 2018 (1,443 accidents), as many as 36.10% of the defects were related to the brake system [8]. The statistics presented provide the basis for discussions between representatives of

the research community and the business community concerning the design of structural solutions for the brake system based on the acquisition and analysis of data generated in the process of the use of vehicles [19].

A systematic literature review identified a research gap related to the small number of publications that identify factors differentiating vehicles with wear or failure of brake system components. Efforts to find the factors that differentiate vehicles in which brake discs and pads have become worn out or faulty are particularly important during the first few years of vehicle use. This concerns anticipation of the costs related to safety, selection of subcontractors, indication of warranty costs, and determination of the extent and frequency of brake system checks and inspections. Attempts to analyze the wear of brake system components are found in the literature. In publication [19], the results of studies presented thus far were extended to include an assessment of the impact of vehicle operating conditions on the brake system wear. The present paper adopts a similar approach, which consists in measuring the thickness of the brake system mechanism components (brake discs and brake pads) at Authorized Service Stations (in Polish, ASO). The measurements were made in real operating conditions when symptoms of malfunction were indicated by the user,

(*) Corresponding author.

E-mail addresses: P. Śliż - piotr.sliz@ug.edu.pl, E. Wycinka - ewa.wycinka@ug.edu.pl

which may indicate wear or a fault of the brake system components. The study considered interventions during the first four years of vehicle use (the period of the manufacturer's warranty, extended warranty, and service under additional vehicle maintenance packages). It should be emphasized that the ex post analysis of events in the warranty process related to the wear of brake systems provides important knowledge on the failure rate, the wear rate, selection and determination of subcontractor participation in warranty costs, estimation of future costs, calculation of vehicle value, but also estimation of the value of additional service packages. Hence, from the perspective of the outlined problems, it is important to identify the factors which may have impact on the accelerated wear of brake systems and their faults.

The main research objective of this paper is identification of factors that differentiate the course of wear and the occurrence of failure in major components of brake system, such as the disc and the pads used in two types of motor vehicles: passenger cars and commercial vehicles produced by two manufacturers, X and Y¹. Two partial objectives were assigned for the work: reconstruction of the brake mechanism diagnosis process at the level of the authorized passenger car service stations and reconstruction of the car operation process in the context of assessment of the wear of the examined safety system using the process mining method.

2. The process of diagnosis and verification of brake systems in the tested group of motor vehicles

The main functions of the brake system include slowing and stopping a motor vehicle, maintaining its speed when driving down a hill, and parking [2]. The design of the brake systems of contemporary passenger cars is characterized by the use of disc and drum brakes [17]. Disc brakes are widely used in many types of vehicles ranging from light motorcycles, through passenger cars and trucks, to trains [20]. Increasingly, they are installed by car manufacturers on both the front and rear axles. This is particularly noticeable in sports cars [e.g., 6]. The main advantage associated with the use of this component in the design of automotive brake systems, as opposed to drum brakes, is better heat dissipation [16]. In the design and operation of vehicles that reach significantly higher acceleration values and maximum speeds, the vehicle user aspect must be considered. It should be considered in the context of damage to the components of the brake system associated with the driving style characterized by intense and repeated braking in short time intervals, resulting in the inability of the brake discs to cool nominally. As a result, the possibility to dissipate the accumulated thermal energy may be limited, i.e., the braking mechanism may reach a state of dysfunction due to the conversion of the vehicle's kinetic energy into thermal energy of a significant value

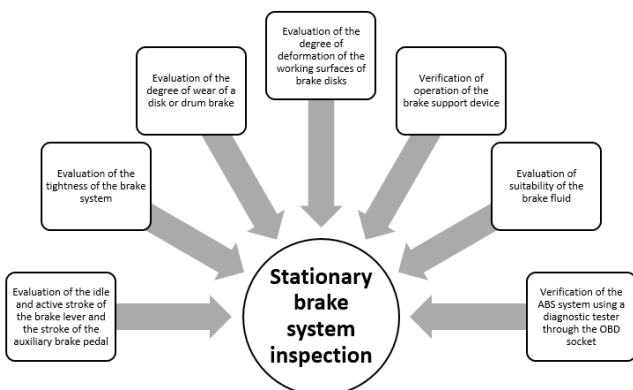

Fig. 1. Methods of assessing the measurement of brake system mechanism components on a stationary stand

¹ The names of companies and authorized service station chains had to be anonymized for publication purposes.

[4, 14]. This condition has a significant impact on the effectiveness of the brake system [13].

Based on an analysis of the warranty claims and repair documentation at authorized service stations, the range of possible measurements (diagnosis) of the brake system mechanism components on a stationary stand was reconstructed (Fig. 1).

The visual inspection of the brake system components, the measurements of brake disc thickness, and the measurements of the curvature of their working zones at a specified radius of the disc in the studied group of units were performed in accordance with the requirements specified in the car manufacturer's technical documentation. The inspection was performed with qualified and trained technicians at authorized service stations of the X and Y car brands. An example of a measuring tool that enables measurement of the curvature of brake discs to determine the deformation level is shown in Figure 2.

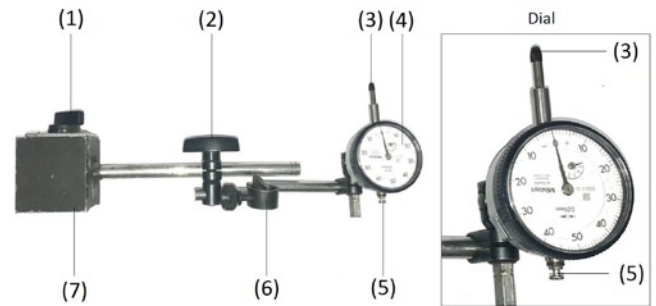

Fig. 2. A dial indicator for measuring the deformation level of brake discs on a magnetic stand

*1 - switch, 2 - controller, 3 - measuring head, 4 - dial, 5 - clock reset, 6 - mounting articulation; and 7 - measuring device mount.

Figure 3A shows the measurement tool while Figure 3B shows how to measure the thickness of a disc mounted on the front axle of a passenger car at an authorized service station. The maximum values of the measurement sensor indications ("maximum deformations") and the minimum values determined during the brake disc thickness measurements, compared to the limit value of this parameter mentioned in the technical documents, are recorded in the measurement cards.

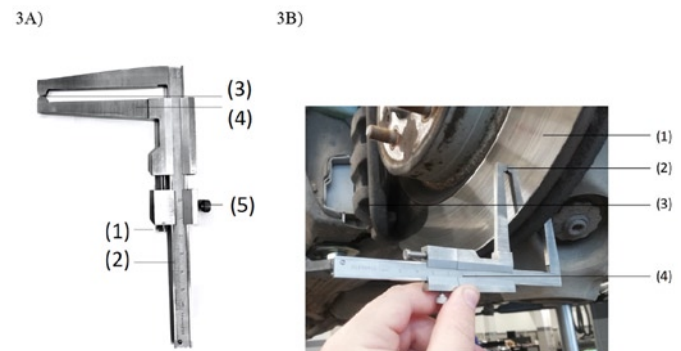

Fig. 3. Caliper used to measure brake disc thickness

*3A) 1 - lever, 2 - bar with the measuring scale (graduated in millimeters), 3 - fixed jaw, 4 - movable jaw, 5 - vernier scale.

*3B) 1 - brake disc, 2 - brake caliper, 3 - measuring location, 4 - measuring tool graduated in millimeters

**Photo 3B - author: Tomasz Fudyma.

Figure 4 shows a summary, compiled from service records, of the interventions associated with repair or replacement of the components of a front axle disc brake mechanism. At this point, it is important to emphasize that the catalogue of interventions presented concerned incidents identified in the first four years of motor vehicle use.

Figure 5 shows the process of brake system components diagnosis, reconstructed from the available analysis of repair documentation for

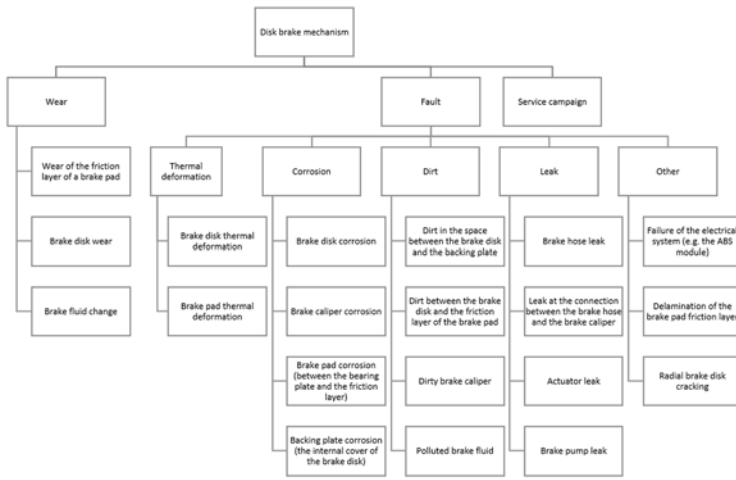

Fig. 4. Types of interventions concerning repair or replacement of disc brake components in the studied units

*Damage categories - not applicable to interventions related to external influences (e.g., post-accident repairs)

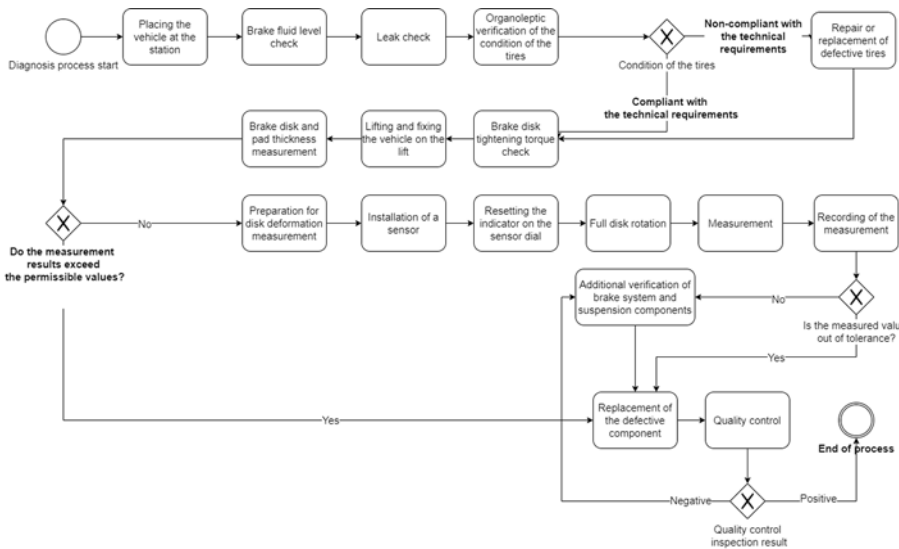

Fig. 5. The process of verification of faults of brake discs and pads in the studied group of motor vehicles of brands X and Y

* The actions to verify the tightening torque of the brake discs include verification of the tightening torque of the bolts holding the vehicle wheel disc and verification of the cleanliness of the interface between the brake disc and the vehicle wheel disc.

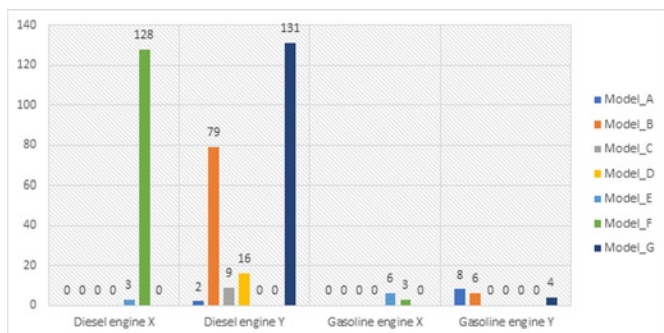

Fig. 6. The characteristics of the motors in terms of its type and the car brand

the studied group of vehicles. The sequence of steps was reconstructed primarily on the basis of repairs related to thickness measurement and deformation due to thermal loading.

As shown in Figure 5, in the first stage of the diagnosis process, the actions intended to identify the issues reported by the customer are the same in the studied group of repairs. Only a visual assessment of the condition of the front axle disc brake components can indicate the need for diagnosis or actions consisting in a direct contact with the technical department of the motor vehicle importer, the vehicle manufacturer, or the component manufacturer.

3. Research procedure and method

3.1. Research sample

The empirical research was conducted in the period of 2018 to 2020 on a sample of 295 cars. The warranty repairs were performed in the years 2014–2018 at Authorized Service Stations. The study comprised a group of seven B-segment car models, manufactured by companies X and Y. The vehicles were homogenous in terms of their installed disc brake mechanism. This means that brake mechanism from the same manufacturer, with the same design and the same dimensions of brake discs, were installed in the studied group of vehicles. Most units in the studied group were diesel-powered (278 cars) with an engine capacity of 1,600 ccm3 (288 cars), and with a manual gearbox (287 cars). All car repairs were divided into two groups according to the reason of malfunction: wear (133 cars) and fault (162 cars).

Figure 6 presents the structure of the analyzed vehicles with respect to the brand (X or Y) and the installed motor.

An attempt was made to analyze the repairs concerning brake discs and pads installed on the front axle in the studied group of motor vehicles in which malfunctions of the brake system components were identified during 4-year service performed at the manufacturer's expense.

Figure 7 shows a photograph of the studied group of brake discs and pads.

It is important to emphasize that, in addition to the components shown in the figure, the disc brake assembly consists of the following main components: the backing layer, the backing plate, the shim, and the brake caliper [17]. Detailed characteristics of the elements are provided in [17].

Table 1 shows the detailed characteristics of the studied brake discs.

In the group of identified repairs, the average value of brake disc thickness was $24.08 \text{ mm} \pm 1.06 \text{ mm}$ (for brake discs mounted on the right side of the motor ve-

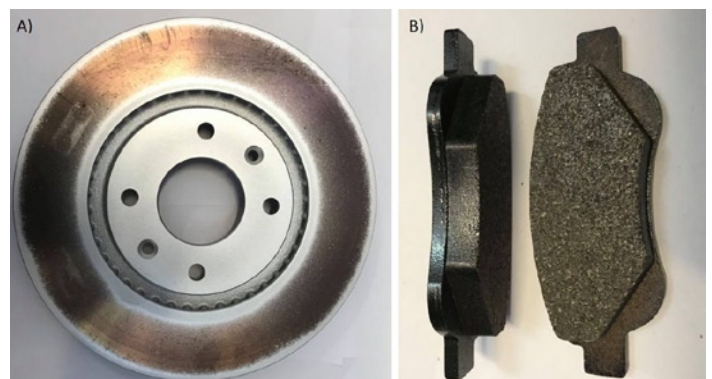

Fig. 7. A photo of the studied brake mechanism components (ventilated brake disc 7A, brake pads 7B)

Table 1. Characteristics of the studied brake discs

Brake disc	
Parameter	Value
Disc type	Ventilated cast iron disc
Diameter	283 mm
Minimum thickness specified by the manufacturer	24 mm
Nominal thickness	26 mm
Wheel hub diameter (center hole diameter)	66 mm
Wheel bolt hole diameter	13 mm
Hole spacing diameter	108 mm
Number of fixing holes	6
Type of ventilation	Internal ventilation
Permissible run-out (deformation) of discs	0.05 mm
Nominal thickness of friction pads	12 mm
Nominal thickness of friction pads	2 mm

Source: own measurement verified with the manufacturers' data.

hicle) and $24.11 \text{ mm} \pm 1.00 \text{ mm}$ (for brake discs mounted on the left side of the aforementioned vehicles).

In the analyzed group of cars, the procedure for measuring the thickness of brake system components was started with measurement of brake discs. If the disc thickness was found to be below the minimum value, the friction pad thickness was not measured or was not recorded. The component was taken out of service and replaced with a new one. Of the 295 cases studied, friction pad thickness measurement was recorded in 91 cases, that is 31%.

3.2. Operational process mining of the studied group of vehicles

In this part of the study, in order to reconstruct the process of operation of the studied vehicles, the process mining method was applied using the Celonis Snap software. The use of the process mining method was justified by the possibility of a reconstruction of the real vehicle operation process, divided into brake discs and pads wear and faults. Examples of the use of this method are described in detail in [3, 7].

The process mining resulted in verification of 297 cases (repairs) and 1,493 actions in the studied group of repairs. Two cases were rejected in a further analysis because the repair was not approved by the manufacturer. At this stage of the process analysis, all recorded cases were included (N=297).

Figure 8 shows the course of the operation process of the studied group of vehicles for the adopted group of interventions related to the front axle brake system.

Figure 8A shows the median throughput time, from which it can be seen that the median time between sale of the vehicle and replacement of the brake discs and pads, due to a fault or wear, is 481 days after purchase and 525 days after vehicle manufacture. In contrast, the values of the arithmetic mean in the studied group are the following: from the sale of the vehicle to repair is 507 days and from the date of manufacture is 569 days. The average repair time was 6 days. As an extension of earlier data, Figure 9 shows the result of the mining of the studied process with a breakdown of the causes of intervention: wear (9A) versus fault (9B).

As can be seen in Figure 9, in the studied group of repairs, the first report of a brake system defect (concerning brake pads and discs mounted on the front axle) occurred within a period of 669 days for a fault and 372 days for wear from the date of sale. It should be emphasized that the long time, respectively 7 and 8 days, from the day the defect was reported to the settlement of the repair with the manufac-

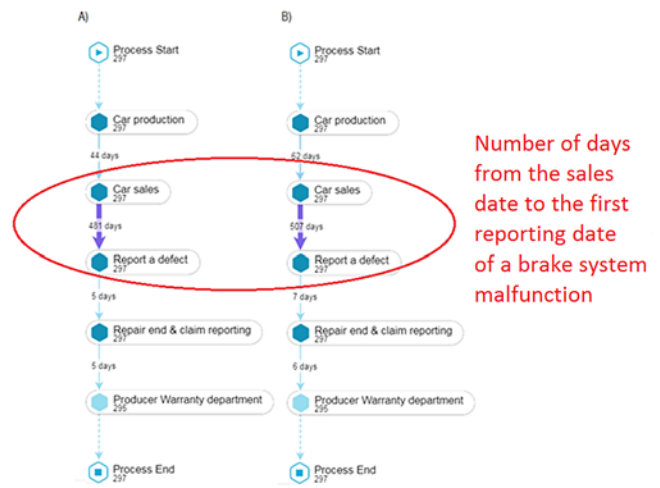

Fig. 8. The course of the operation process in the studied repair group
Source: prepared by the authors based on the completed study using the Celonis SNAP software.

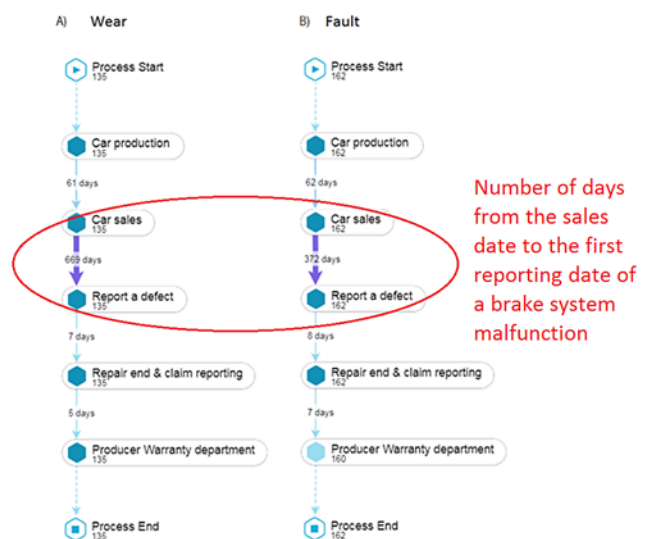

Fig. 9. The course of the operation process in the studied repair group
*Process mining was performed for 135 repairs due to a wear (Figure 9A) and 162 repairs due to fault (Figure 9B).
Source: prepared by the authors based on the completed study using the Celonis SNAP software.

turer's warranty department. In the course of the empirical research, factors affecting the duration of the warranty process were identified. In the case of repairs related to replacement of discs and pads, for both types of interventions the following were qualified: lack of availability of spare parts at the ASS warehouse (due to a change in rules of spare parts availability resulting from their generally available distribution from the warehouses of car manufacturers or distributors associated with the car manufacturer), prolonged warranty procedure in the case of interventions related to the brake system (exceeding 14 working days), and immediate contact of the vehicle user with the service center after a fault has occurred without earlier agreeing on the date of the repair, which increased the load on the work schedule of the ASS staff. In summary, the use of the process mining method, for selected types of faults, can provide information on parts storage and estimation of warranty costs for selected models and types of faults.

3.3. Characteristics of the studied vehicles

The database of the car repairs concerning the studied brake system components was prepared using the warranty repair database reconstructed on the basis of repair orders.

Table 2. Characteristics of the studied variables

Variable	Class	Description
ID_case	[character]	A unique number of the warranty report that identifies the completed intervention (repair)
Prod_date	[date, format = "%Y-%m-%d"]	The vehicle production date
Repair_date	[date, format = "%Y-%m-%d"]	The date of the repair, the date on which the customer reported the fault to the authorized service station
Warranty_start	[date, format = "%Y-%m-%d"]	The start date of the warranty period of the vehicle, also identified as the date of sale
Age	[numeric]	The number of the vehicle's days in service, identified as the difference between Repair date and Warranty start
Mileage	[numeric]	The value of the mileage of the vehicle read at the time of the customer's fault report
Brand	[character]	The brand of the vehicle
Model	[character]	The vehicle model
Claim_type	[character]	The report type (1 - manufacturer warranty, 2 - supplementary warranty, 3 - vehicle maintenance)
Cause	[character]	The code for the cause of the reported fault determined by the workshop at the authorized service station
Cause_wear	[logical]	Indication of wear of a brake system component (1=yes, 0=no)
Cause_deformation	[logical]	Indication of a fault of a brake system component (1=yes, 0=no)
Disc_R	[numeric]	The thickness of the right front brake disc [mm]
Disc_L	[numeric]	The thickness of the left front brake disc [mm]
Pads_front	[numeric]	The thickness of the front friction pads [mm] The minimum value from the external and internal measurement of the left and right pads.
Deformation_R	[numeric]	The value of the run-out of the right brake disc [mm]
Deformation_L	[numeric]	The value of the run-out of the left brake disc [mm]

Source: prepared by the author.

Table 2 shows the characteristics of the variables in the relational database that was developed, on the basis of which the statistical analyses discussed in the next chapter of the paper were performed.

Using the collected empirical data, an attempt was made to conduct a statistical analysis of the factors that characterize the vehicles reported to the service center due to a fault or wear of the brake system. Seven factors were identified whose distributions were analyzed in the groups of vehicles in which, during the warranty period, brake discs and pads wear occurred and in the group of vehicles with faults:

- **Vehicle type** (car_type): passenger car or commercial vehicle.
- **Vehicle brand** (brand): brand X or brand Y.
- **Vehicle model** (model): 7 vehicle models were considered in the study.
- **Engine type** (engine_type): diesel/spark ignition engine.
- **Engine capacity** (engine_capacity): in the studied group of engines, engines with capacity of 1,200 ccm3 and 1,600 ccm3 were identified.
- **Gearbox type** (gearbox_type): automatic gearbox or manual gearbox.
- **Mileage** (mileage): expressed in kms, as read at the time of the fault report.
- **Vehicle age (months)**: counted in months of vehicle use, calculated as the difference between the date the car was reported for service and the date of manufacture.

The structure of the sample is shown in Table 3.

The hypothesis was put forward that the distributions of the above variables differ in the group of cars in which a fault occurred and the group of cars in which the brake system elements were worn out. Both groups were analyzed separately and the hypothesis was verified by appropriate statistical tests.

Identification of the regularities that characterize the vehicles reported for service due to brake disc wear or fault should start with identification of the distributions of the variables that describe the ve-

Table 3. The structure of the sample according to selected factors

Variable	Attribute	N
Gearbox type	Manual	287
	Semi Automatic	7
	Automatic	1
Engine capacity	1200 [cm ³]	7
	1600 [cm ³]	288
Engine type	Diesel engine	278
	Gasoline engine	17
Vehicle brand	X	126
	Y	169

hicles. These variables can be numerical (e.g., mileage, vehicle age, brake disc thickness, etc.) or non-numerical (e.g., car model, gearbox type, etc.). In the case of the numerical variables, the choice of the method of further analysis depends on the type of distribution of the respective variable [9].

When the variables have a normal distribution, the analysis can be carried out using parametric methods, while for other types of statistical distributions (often skewed ones) non-parametric methods are required. The assumption of equality of the empirical distribution with the normal distribution is verified with one of the normality tests. In the present study, the Kolmogorov-Smirnov normality test with a Lilliefors correction was used [1]. Since distributions of all analyzed characteristics were not normal, the evaluation of the differences in the distributions of the numerical variables was obtained

using the non-parametric Mann-Whitney test (when two distributions were compared) and the non-parametric Kruskal-Wallis ANOVA test (when more than two distributions of variables were compared).

In the case of non-numeric variables (e.g., vehicle brand, vehicle model, engine type, etc.), it is important to analyze the frequency of attributes of these variables in the sample. In the case of a variable with a large number of minor attributes, it is necessary to combine them into homogeneous and sufficiently numerous groups. Dichotomous variables whose attributes are very minor cannot be used in further analysis. For non-numeric variables on a nominal scale, an analysis of association can be carried out using multiple correspondence analysis.

4. Results

4.1. Reason of malfunction and characteristics of the repaired vehicles

In the sample, the malfunction of the front brake system components (brake pads and discs) was reported in 133 vehicles due to wear

and in 162 vehicles due to failure. Tables 4 and 5 show the descriptive statistics of the variables presented in Tables 1 and 2 that characterize the repaired vehicles. Repairs were divided into repairs due to a fault (Table 4) and due to wear (Table 5). All of these variables were quantitative. The hypotheses of the normality of their distributions were verified at the next stage. Results are shown in Table 6.

All the variables except for friction pad thickness have a distributions other than the normal distribution (Table 6). Therefore, in the further part of the study, non-parametric tests were used to analyze the properties of the distributions as well as correlation between variables and to test the hypotheses that the sample of cars repaired due to fault and the sample of cars repaired due to wear come from the same distribution. For the reason that non-parametric tests do not require the assumption that variables are normally distributed, they were used in this study.

The correlation between the variables was examined using the Spearman's rank correlation coefficient separately for the vehicles in the fault group (Table 7) and the wear group (Table 8).

Table 4. The descriptive statistics of the variables characterizing vehicles with malfunction in the brake disc and pad due to fault

Variable	N	Mean	Median	Min	Max	Lower quartile	Upper quartile	Standard deviation
Age [months]	162	12,05	10,28	1,5	46,9	6,1	16,1	8,13
Mileage [km]	158	27971,55	22829	841	199703	12109	32726	27879,9
Right brake disc thickness [mm]	58	24,89	25,13	20	25,9	24,5	25,5	0,93
Left brake disc thickness [mm]	58	24,86	25,01	20	25,9	24,5	25,5	0,92
Right brake disc deformation [mm]	99	0,06	0,06	0,02	0,1	0,05	0,07	0,02
Left brake disc deformation [mm]	98	0,06	0,06	0,01	0,1	0,05	0,07	0,02
Friction pad thickness [mm]	10	5,45	5,25	2	9	3,5	8	2,53

Table 5. The descriptive statistics of the variables characterizing cars with malfunction in the brake disc and pad due to wear

Variable	N	Mean	Median	Min	Max	Lower quartile	Upper quartile	Standard deviation
Age [months]	133	21,45	20,5	3,4	56,8	14,50	26,13	9,94
Mileage [km]	131	60737,17	53625	698	161985	44739	74775	25937,63
Right brake disc thickness [mm]	99	23,6	23,7	19,5	27*	23,45	23,95	0,81
Left brake disc thickness [mm]	99	23,68	23,7	19,5	27*	23,45	24	0,76
Right brake disc deformation [mm]	0	-	-	-	-	-	-	-
Left brake disc deformation [mm]	0	-	-	-	-	-	-	-
Friction pad thickness [mm]	81	2,03	2	0	5,5	1	3	1,18

*The MAX value for the variables Right disc thickness [mm] and Left disc thickness [mm] referred to a single intervention performed on a new car (during pre-delivery inspection).

Table 6. The results of the analysis of normality of the studied variables

Variable	Normality tests	Conclusion: is the distribution normal?
Age [months]	K-S d=,10308, p<,01 ; Lilliefors p<,01	No
Mileage [km]	K-S d=,09384, p<,05 ; Lilliefors p<,01	No
Right brake disc thickness [mm]	K-S d=,15888, p<,15 ; Lilliefors p<,01	No
Left brake disc thickness [mm]	K-S d=,13782, p<,01 ; Lilliefors p<,01	No
Right brake disc deformation [mm]	K-S d=,15357, p<,05 ; Lilliefors p<,01	No
Left brake disc deformation [mm]	K-S d=,15192, p<,05 ; Lilliefors p<,01	No
Friction pad thickness [mm]	K-S d=,17934, p>,20; Lilliefors p>,20	Failure to reject the null hypothesis about the normality of the distribution in population

Table 7. The Spearman's rank correlation coefficients for cars repaired due to fault of brake disc and pad

Variable	Age [months]	Mileage [km]	Right brake disc thickness [mm]	Left brake disc thickness [mm]	Right brake disc deformation [mm]	Left brake disc deformation [mm]	Friction pad thickness [mm]
Age [months]	1.000	0.710*	-0.527*	-0.472*	0.161	0.251*	-0.226
Mileage [km]	0.710*	1.000	-0.483*	-0.483*	0.230*	0.269*	-0.829*
Right brake disc thickness [mm]	-0.527*	-0.483*	1.000	0.924*	-0.123	-0.209	0.781*
Left brake disc thickness [mm]	-0.472*	-0.483*	0.924*	1.000	-0.083	-0.138	0.797*
Right brake disc deformation [mm]	0.161	0.230*	-0.123	-0.083	1.000	0.677*	-0.324
Left brake disc deformation [mm]	0.251*	0.269*	-0.209	-0.138	0.677*	1.000	-0.471
Friction pad thickness [mm]	-0.226	-0.829*	0.781*	0.797*	-0.324	-0.471	1.000

*Statistically significant at 0.05 significance level

Table 8. The Spearman's rank correlation coefficients for cars repaired due to wear of brake disc and pad

Variable	Age [months]	Mileage [km]	Right brake disc thickness [mm]	Left brake disc thickness [mm]	Friction pad thickness [mm]
Age [months]	1.000	0.314*	-0.054	-0.085	-0.066
Mileage [km]	0.314*	1.000	-0.107	-0.053	0.038
Right brake disc thickness [mm]	-0.054	-0.107	1.000	0.924*	0.120
Left brake disc thickness [mm]	-0.085	-0.053	0.924*	1.000	0.128
Friction pad thickness [mm]	-0.066	0.038	0.120	0.128	1.000

*Statistically significant at 0.05 significance level

In the case of the vehicles in the fault group, most of the variables are statistically significantly correlated. However, in the case of the vehicles in the wear group, only the age and mileage of the vehicle and the thickness of the left and right discs are significantly positively correlated. In the case of the correlation between age and mileage, it should be noted that the strength of the correlation is much lower than for the vehicles in the fault group. Figure 10 shows the distribution of vehicle mileage by year of operation and reason for vehicle servicing.

To verify whether differences in distributions of the variables in the wear and fault groups were significant, the Mann-Whitney test was used. The results are shown in Table 9. As can be seen from the data in Table 9, all the examined distributions are statistically significantly different. The distributions of the variables in both groups (wear and fault) are shown using box-plots in Figure 11.

As can be seen in Figure 11, when comparing the data on the service interventions and dividing them into the wear and fault groups, it was noted that the reports related to faults involve a lower mileage than those related to wear (Figure 11b). This means that faults occur much earlier (Figure 11a). It should also be noted that vehicles reported for wear had smaller disc thickness (right and left) than those reported for fault (Figures 11c and 11d). A similar effect is seen in the thickness of the friction pads (Figure 11e).

4.2. Factors that differentiate the serviced vehicles

4.2.1. Factor I: vehicle type

As discussed in the previous subsection, the distributions of the variables describing the serviced vehicles were statistically significantly different in the group of vehicles with brake system wear and in the group of vehicles with a fault. In order to identify the characteristics of the vehicles in each of these groups, an attempt was made to

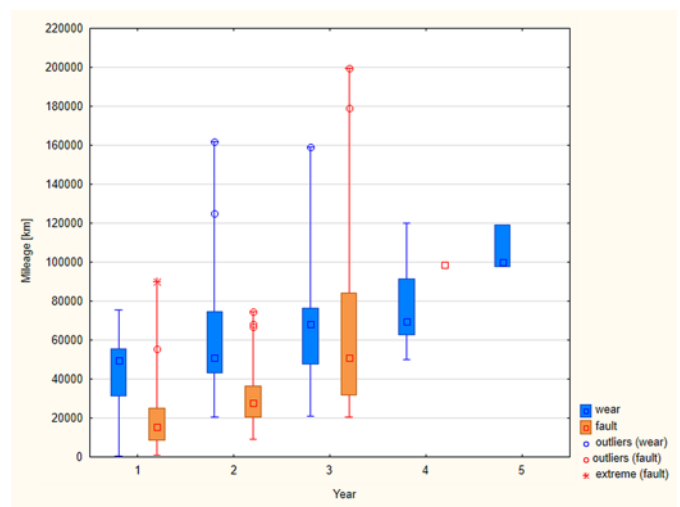

Fig. 10. Box plots of vehicle mileage by year of operation and reason for servicing

analyze the variation in the intensity of use of the brake system measured by disc thickness and deformation. Analyses were performed on the groups of vehicles distinguished according to the identified factors (brand; model; type of motor vehicle; engine; gearbox type; engine type and capacity).

First, the focus was on the variable defining the type of the studied vehicle. Based on the collected empirical data, two types of vehicles (car_type) were distinguished: passenger cars and commercial vehicles. Tables 10 and 11 show the results of the non-parametric analysis of the differences between distributions of the variables that describe the condition of the brake system in commercial vehicles and passen-

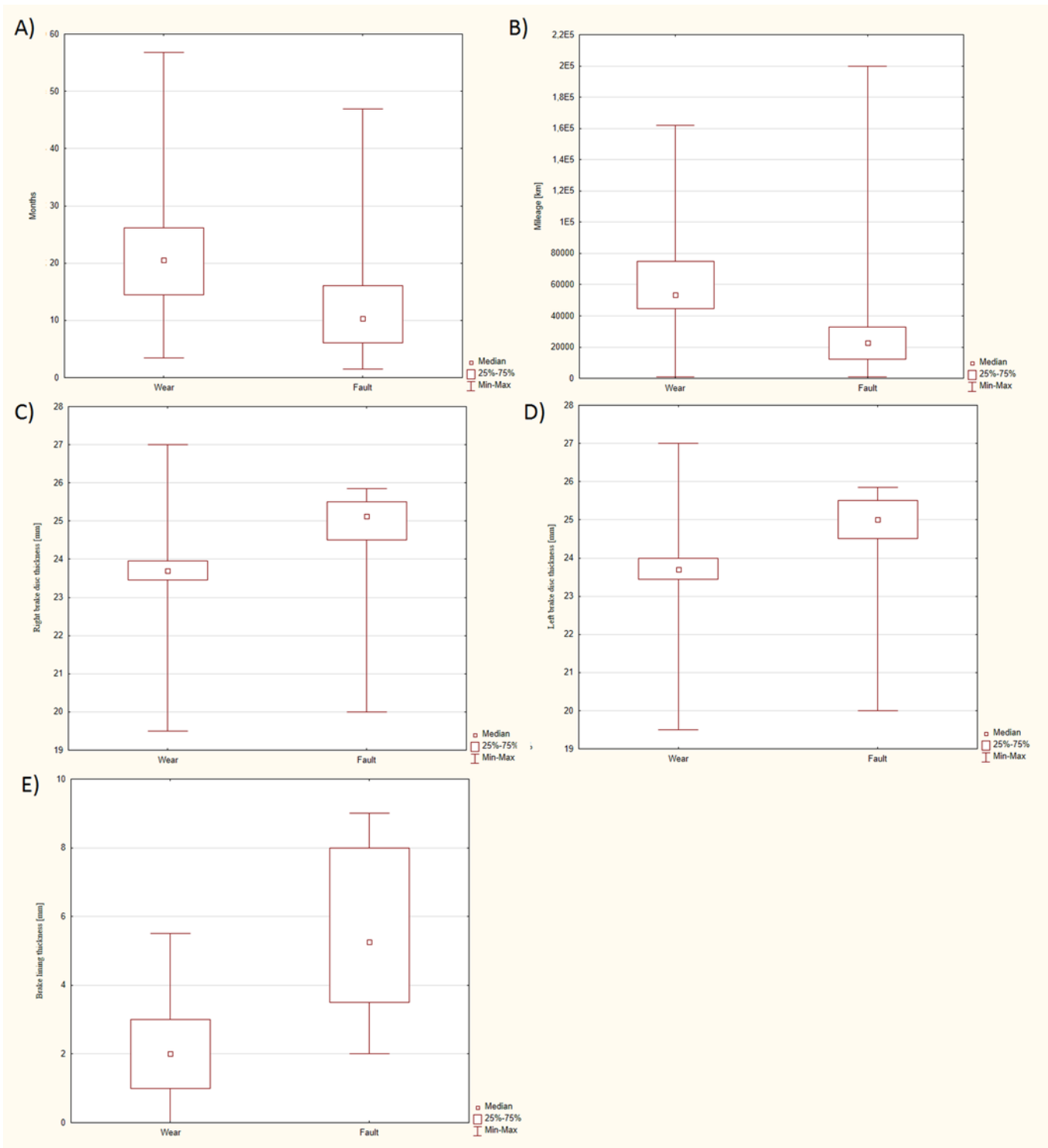

Fig. 11. Box plots of the distributions of the variables describing the vehicles reported under warranty for wear or fault of the brake system

ger cars, separately for vehicles reported due to wear (Table 10) and due to a fault (Table 11).

Among the vehicles reported due to a fault, passenger cars had thicker right-hand brake discs than commercial vehicles. The remaining variables were not statistically significantly different in the passenger car and commercial vehicle groups. The distributions of the thickness of the right brake discs in both groups of vehicles are shown in Figure 12.

An analogous analysis was completed for the group of vehicles serviced due to wear of a brake system. The results are shown in Table 11. In the group of vehicles reported due to wear, there were no sta-

tistically significant differences in the distributions of the analyzed variables.

4.2.2. Factor II: car body

As a second factor, the following three groups of car bodies were distinguished:

- **Group I:** Van / Minibus
- **Group II:** Van
- **Group III:** Crossover / Minivan / Wagon / Station Wagon / Com-bivan / Hatchback / Sport Coupe

Table 9. Evaluation of the significance of the differences in the distribution of variables between the wear and fault groups

Variable	Mann-Whitney U test			
	Z	p	N Wear Group	N Failure Group
Age [months]	8,40788	0,000000	133	162
Mileage [km]	11,00955	0,000000	131	158
Right brake disc thickness [mm]	-8,55215	0,000000	99	58
Left brake disc thickness [mm]	-8,25575	0,000000	99	58
Right brake disc deformation [mm]	-	-	0	99
Left brake disc deformation [mm]	-	-	0	98
Friction pad thickness [mm]	-4,15590	0,000032	81	10

Table 10. The Mann-Whitney U test for the distributions of the variables describing the malfunction of the brake system in passenger cars and commercial vehicles in the group of motor vehicles reported due to a fault

Variable	Z	p-value	N Passenger cars	N Commercial vehicles
Right brake disc thickness [mm]	2,06239	0,039172*	44	14
Left brake disc thickness [mm]	1,73531	0,082686	44	14
Right brake disc deformation [mm]	-0,57754	0,563575	80	19
Left brake disc deformation [mm]	-1,03792	0,299307	79	19
Friction pad thickness [mm]	1,38580	0,165808	6	4

*Statistically significant at 0.05 significance level

Table 11. The Mann-Whitney U test for the distributions of the variables describing the malfunction of the brake system in passenger cars and commercial vehicles in the group of motor vehicles reported due to wear

Variable	Z	p	N Passenger cars	N Commercial vehicles
Right brake disc thickness [mm]	0,727109	0,467160	56	43
Left brake disc thickness [mm]	0,522389	0,601400	56	43
Right brake disc deformation [mm]	-	-	0	0
Left brake disc deformation [mm]	-	-	0	0
Friction pad thickness [mm]	0,051986	0,958540	42	39

To test whether the variables describing the vehicles have the same distributions in the identified three groups, a non-parametric analysis of variance (Kruskal Wallis ANOVA) was applied. The test results for the group of vehicles reported due to wear of braking system components are shown in Table 12.

In the vehicles reported due to wear, at least in one group (by vehicle type) the thickness of the right disc is different from those in the other groups. Pairwise tests (post-hoc analysis) were conducted for this variable to determine the groups with differences (Table 13).

Of the pairs analyzed, a statistically significant difference was found only for the Group I - Group III pair. This means that the thickness of the right brake disc in the vehicles reported due to wear was higher in Group III (crossover, etc.) than in Group I (van/minibus). Groups I (van/minibus) and II (van) have no statistically significant differences.

The distributions of right disc thickness in the three groups analyzed are shown in Figure 13.

An analogous analysis was made for the group of vehicles reported due to brake system fault. The results of the non-parametric analysis of variance are shown in Table 14.

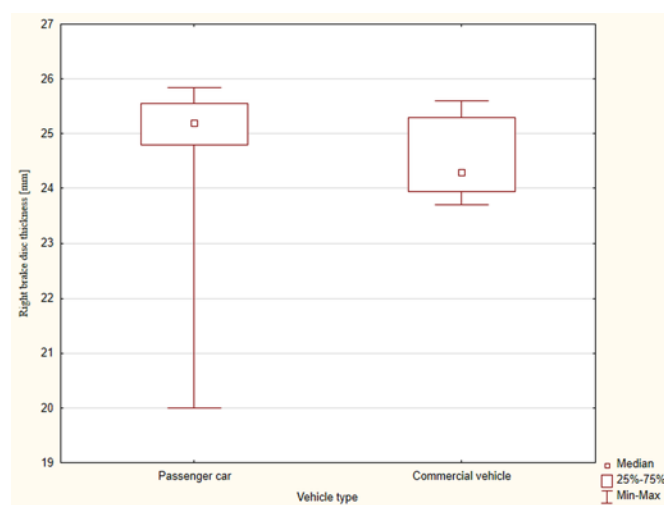

Fig. 12. Box plots of the distribution of the thickness of the right discs in the vehicles reported due to a fault

Table 12. Non-parametric analysis of variance (Kruskal-Wallis ANOVA) for variables describing the vehicles with different body types reported due to wear of braking system components

Variable	H	P	N Group I	N Group II	N Group III
Right brake disc thickness [mm]	6,331	0,0422*	35	43	21
Left brake disc thickness [mm]	4,579	0,1013	35	43	21
Right brake disc deformation [mm]	0	1	35	43	21
Left brake disc deformation [mm]	0	1	35	43	21
Friction pad thickness [mm]	0,6805	0,7116	26	39	16

*Statistically significant at 0.05 significance level

Table 13. Post-hoc tests (p-values) in the variance analysis for the Disc R variable according to groups of vehicles of different body types reported due to wear of braking system components

Group:	Group I R:44,700	Group II R:47,605	Group III R:63,738
Group I		1,000000	0,049011*
Group II	1,000000		0,104611
Group III	0,049011*	0,104611	

*Statistically significant at 0.05 significance level

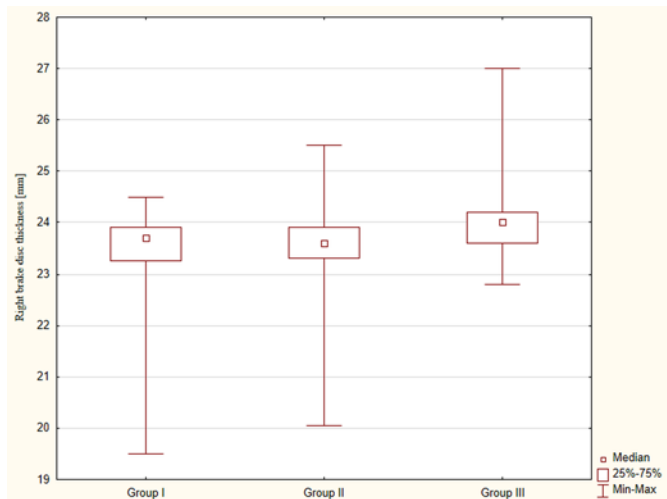

Fig. 13. Box plots of the distributions of the right disc thickness in the vehicles reported due to wear in groups of vehicles with different body types

As a result, no statistically significant differences were identified in the distributions of the analyzed variables in the group of vehicles reported due to a fault.

Table 14. Non-parametric analysis of variance (Kruskal-Wallis ANOVA) for variables describing the brake system according to groups of vehicles with different body types reported due to a fault

Variable	H	p	N Group I	N Group II	N Group III
Right brake disc thickness [mm]	4,3983	0,1109	21	14	23
Left brake disc thickness [mm]	3,3418	0,1881	21	14	23
Right brake disc deformation [mm]	2,0731	0,3547	39	19	41
Left brake disc deformation [mm]	1,1140	0,5729	38	19	41
Friction pad thickness [mm]	3,6051	0,1649	3	4	3

*Statistically significant at 0.05 significance level

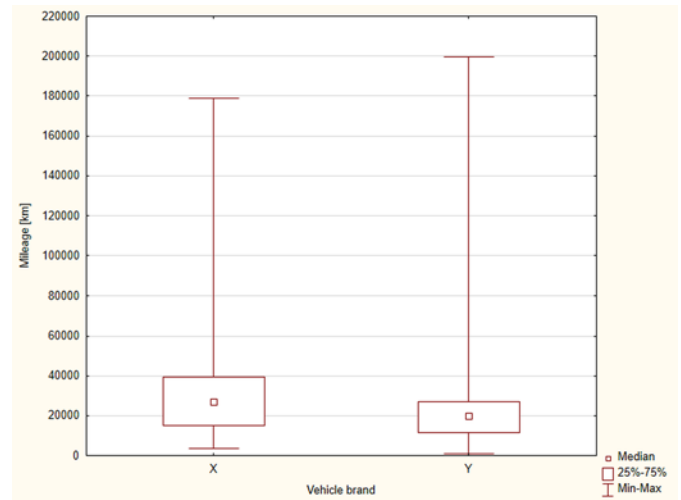

Fig. 14. Box plots of the mileage distribution of the vehicles reported due to a fault for brands X and Y

4.2.3. Factor III: Vehicle brand

Another factor analyzed was the vehicle brand. Two vehicle brands were analyzed. Due to the need to anonymize them, they are referred to as X and Y. The sample included 126 motor vehicles of brand X and 169 motor vehicles of brand Y. To verify the hypotheses that vehicles repaired due to brake system wear (Table 15) and due to a fault (Table 16) have the same distributions, the Mann-Whitney U test was applied. Results are presented in Table 15 for the wear group and in Table 16 for the fault group.

The distributions of variables describing the intensity of use of motor vehicles of brands X and Y serviced due to wear are not significantly statistically different. However, in the group of motor vehicles serviced due to a fault, cars of brand X had higher mileage (Table 16 and Figure 14).

Table 15. The Mann-Whitney U test for the distributions of the variables describing the malfunction of the brake system in motor vehicles of brand X and Y in the group of motor vehicles reported due to wear

Variable	Z	P	N Brand X	N Brand Y
Right brake disc thickness [mm]	0.06087	0.951463	39	60
Left brake disc thickness [mm]	0.05371	0.957167	39	60
Right brake disc deformation [mm]	0.00000	1.000000	0	0
Left brake disc deformation [mm]	0.00000	1.000000	0	0
Friction pad thickness [mm]	-1.70042	0.089053	31	50
Mileage [km]	-0.17493	0.861137	65	66
Age [months]	-1.76632	0.077344	66	67

Table 16. The Mann-Whitney U test for the distributions of the variables describing the malfunction of the brake system in motor vehicles of brand X and Y in the group of motor vehicles reported due to fault

Variable	Z	P	N Brand X	N Brand Y
Right brake disc thickness [mm]	-1.21013	0.226231	18	40
Left brake disc thickness [mm]	-1.72275	0.084935	18	40
Right brake disc deformation [mm]	0.05710	0.954462	30	69
Left brake disc deformation [mm]	0.06552	0.947760	30	68
Brake lining thickness [mm]	-1.04447	0.296271	2	8
Mileage [km]	3.00124	0.002689*	58	100
Age [months]	1.60757	0.107930	60	102

Because in the studied sample, the majority were vehicles with 1,600 cm³ diesel engines and manual gearboxes (cf. Table 3), it was not possible to investigate the relationship between such factors as gearbox type, engine capacity, and engine type and brake system malfunction.

4.3. Multidimensional analysis of the diversity of vehicles

A multiple correspondence analysis was used to detect and represent the relationships between the studied variables. This analysis enables graphical representation of simultaneous occurrence of categories of the analyzed variables. The variables used in the correspondence analysis should be on a nominal scale or at most on an ordinal scale. The analysis covered following variables, which in univariate analyses were significantly correlated with the reason for the vehicle being reported for servicing: vehicle age, vehicle mileage, vehicle type (commercial vehicle/passenger car), and vehicle brand. The first two of these variables were measured on a ratio scale and, therefore, they were converted to an ordinal scale in the first step. Vehicle age was presented in years of use, while the mileage was dichotomized into groups: up to 39,850 km and over 39,850 km. The dichotomization was performed using the C&RT exhaustive partitioning method to maximize the discriminatory power of the mileage variable when predicting the value of fault type variable. The Gini coefficient was used as a measure of goodness of fit in the discrimination procedure.

The most popular form of presentation of the results of the correspondence analysis is presentation of the points that describe the levels of the variables in a two-dimensional distribution of eigenvalues. Usually, the first two eigenvalues that explain the largest percentage of inertia are presented. Interpretation of the graph consists in observing the position of the points representing the attributes of each variable relative to other points and relative to the center of the coordinate system. Classification methods can be used to identify groups of related points (those nearest to each other) [10]. Ward's method of

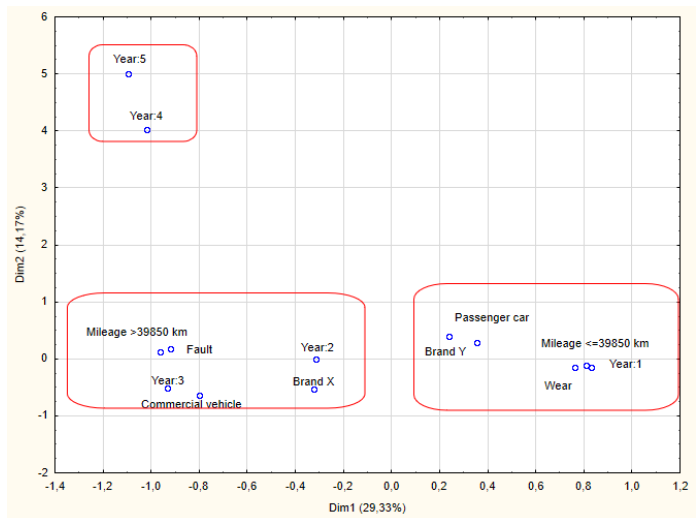

Fig. 15. Multiple correspondence analysis of the characteristics describing the vehicles serviced due to wear or fault of the brake system

hierarchical classification is used in the present paper. Three groups marked with red rectangles in the graph were identified (Figure 15).

As shown in Figure 15, the vehicles were classified into the following groups:

- **Group one** - vehicles that were reported due to wear. These are also vehicles with mileage over 39,850 km, in their second or third year of use. These are X brand commercial vehicles.
- **Group two** - vehicles that were reported due to a fault. These are Y brand passenger cars with mileage up to 39,850 km and in the first year of use.

- **Group three** - cars reported in the 4th and 5th year of use. The large distance of the two points constituting this group from the others indicates that there is no interaction with any of the other analyzed variables and their levels.

At this point, it is important to emphasize that the vehicles reported due to a fault were in the first year of use with low mileage (up to 39,850 km). At the same time, the thickness of the brake discs and friction pads in these vehicles was greater than in the vehicles reported due to wear (cf. Tables 4 and 5). Based on the results of the multiple correspondence analysis, it can also be concluded that reports of fault are involved with passenger cars of the Y brand. In contrast, the vehicles reported for wear were in their third or, more rarely, second year of use and had higher mileage. These were X brand commercial vehicles. In the commercial vehicles, the brake disc thickness was smaller than in passenger cars, which is related to the previous observations.

5. Conclusions

The approach presented herein to the identification and analysis of the factors that differentiate the course of wear and the occurrence of faults in brake system components in motor vehicles with the use of statistical methods is an original solution. It can be applied by both researchers studying similar problems and by organizations operating in the automotive sector.

As a result of the empirical process, three generalizing conclusions were formulated:

1. Vehicles reported for service due to brake system wear or fault have different characteristics. Their identification makes it possible to predict which vehicles and at what time of use will be reported due to malfunction of the brake system. The distributions of analyzed variables that describe the intensity of use of vehicles are not normal, hence in their analysis it is necessary to use non-parametric measures. In particular, quartiles should be used in describing the central tendency rather than measures based on the arithmetic mean. The use of multiple correspondence analysis makes it possible to study of relationships between the factors that characterize the intensity of use of the vehicles.
2. The results presented herein may have a positive impact on the efficiency and effectiveness of activities associated with

the diagnosis and repairs of brake systems in motor vehicles. Moreover, the results obtained, in the utilitarian space, can provide new knowledge to car manufacturers regarding an analysis of the quality of the components and parts ordered as well as the selection of subcontractors (Original Equipment Manufacturers - OEM).

3. The study outlines an area for improvement in the production processes, selection of parts manufacturers, and diagnosis and repair of the described brake system components, in the context of the prediction of the costs related to parts wear and faults.
4. The relationship between such characteristics of the studied motor vehicles as vehicle type, body type, vehicle brand and model and the cause and time of reporting of a malfunction of brake system components was demonstrated.

At this point, it is necessary to outline the limitations of the empirical procedure carried out. First is a focus on a four-year service period of the studied group of vehicles. Second, possible errors exist in the measurement of the thickness and deformation of the studied group of brake system components, which were beyond the authors' control. The authors outline new directions of research that focus on broadening the study by an attempt to enlarge the list of factors that differentiate the brake system components by adding variables describing the steering system and the vehicle suspension. Additionally, the sample size and the observation period should be increased, taking into consideration repairs carried out in the warranty period, as well as paid repairs.

Acknowledgements

The authors would like to acknowledge the many valuable and insightful comments made by anonymous reviewers, which enhanced the substantial value of the paper and helped to give it its final shape. Moreover, the authors would like to thank Mr. Maciej Fusiewicz, the deputy manager of the authorized service station acting as a Renault COTECH and ZE-EV Expert, for substantial advice he provided in the course of our work on the paper.

References

1. Albright S C, Winston W L, Albright S C. Business analytics: data analysis and decision making. 5th edition. Stamford, CT, USA, Cengage Learning: 2014.
2. Bhane A B, Salodkar S M, Ramani H B. Braking System Approaching towards the Betterment and It's Consequences. International Research Journal on Advanced Science Hub 2020; 2: 64-70, <https://doi.org/10.47392/irjash.2020.236>.
3. Bitkowska A, Sliż P, Tenbrink C, Piasecka A. Application of Process Mining on the Example of an Authorized Passenger Car Service Station in Poland. Foundations of Management 2020; 12(1): 125-136, <https://doi.org/10.2478/fman-2020-0010>.
4. Breuer B, Bill K H. Menschliche Anforderungen. In Breuer B, Bill KH (eds): Bremsenhandbuch, Wiesbaden, Vieweg+Teubner Verlag: 2004: 38-48, https://doi.org/10.1007/978-3-322-99535-3_4.
5. Dvadnenko V, Arhun S, Bogajevskiy A, Ponikarovska S. Improvement of economic and ecological characteristics of a car with a Start-Stop system. International Journal of Electric and Hybrid Vehicles 2018; 10(3): 209, <https://doi.org/10.1504/IJEHV.2018.097377>.
6. Ebrahimi N S, Kheybari M. Brake system design for sport cars using digital logic method. Automotive Science and Engineering 2017; 7(4): 2571-2582.
7. Garcia C dos S, Meincheim A, Faria Junior E R et al. Process mining techniques and applications - A systematic mapping study. Expert Systems with Applications 2019; 133: 260-295, <https://doi.org/10.1016/j.eswa.2019.05.003>.
8. GOV.UK. Number of road accidents caused by vehicle defect factors in Great Britain (UK) in 2018. 2019.
9. Hardy M, Bryman A. Handbook of data analysis. Los Angeles ; London, SAGE: 2009.
10. Hjellbrekke J. Multiple correspondence analysis for the social sciences. Abingdon, Oxon ; New York, NY, Routledge, Taylor & Francis Group: 2019.
11. Jensen A F, Mabit S L. The use of electric vehicles: A case study on adding an electric car to a household. Transportation Research Part A: Policy and Practice 2017; 106: 89-99, <https://doi.org/10.1016/j.tra.2017.09.004>.
12. Likhonov V A, Rossokhin A V. Optimization of environmental performance of a car diesel engine running on natural gas by reducing carbon black in the exhaust gas. IOP Conference Series: Materials Science and Engineering 2020; 862: 062046, <https://doi.org/10.1088/1757-899X/862/6/062046>.

13. Milenkovic P, Jovanovic S, Jankovic A et al. The influence of brake pads thermal conductivity on passenger car brake system efficiency. *Thermal Science* 2010; 14(suppl.): 221-230, <https://doi.org/10.2298/TSCI100505016M>.
14. Nakanishi H. Development of aluminum metal matrix composites (Al-MMC) brake rotor and pad. *JSAE Review* 2002; 23(3): 365-370, [https://doi.org/10.1016/S0389-4304\(02\)00203-5](https://doi.org/10.1016/S0389-4304(02)00203-5).
15. Ortar N, Ryghaug M. Should All Cars Be Electric by 2025? The Electric Car Debate in Europe. *Sustainability* 2019; 11(7): 1868, <https://doi.org/10.3390/su11071868>.
16. Owen C E, Eichhorn L, Eichhorn L. Shop manual for automotive brake systems. 5th ed. Clifton Park, NY, Delmar Cengage Learning: 2011.
17. Rashid A. Overview of disc brakes and related phenomena - a review. *International Journal of Vehicle Noise and Vibration* 2014; 10(4): 257, <https://doi.org/10.1504/IJVNV.2014.065634>.
18. Sivaraj G, Parammasivam K, Suganza G. Reduction of aerodynamic drag force for reducing fuel consumption in road vehicle using basebleed. *Journal of Applied Fluid Mechanics* 2018; 11(6): 1489-1495, <https://doi.org/10.29252/jafm.11.06.29115>.
19. Świdorski A, Borucka A, Jacyna-Gołda I, Szczepański E. Wear of brake system components in various operating conditions of vehicle in the transport company. *Eksploracja i Niezawodność - Maintenance and Reliability* 2018; 21(1): 1-9, <https://doi.org/10.17531/ein.2019.1.1>.
20. Yang Y-C, Chen W-L. A nonlinear inverse problem in estimating the heat flux of the disc in a disc brake system. *Applied Thermal Engineering* 2011; 31(14-15): 2439-2448, <https://doi.org/10.1016/j.applthermaleng.2011.04.008>.