

FEM analysis of magnetic field and forces in area ARC fault of autotransformer HV winding

DARIUSZ KOTERAS

*Opole University of Technology, Department of Industrial Electrical Engineering
ul. Proszkowska 76, 45-758 Opole
e-mail: d.koteras@po.opole.pl*

(Received: 10.07.2014, revised: 08.09.2014)

Abstract: In this paper the electric arc fault in the high voltage winding turn of the power autotransformer has been investigated. 3D magnetic field distributions in the leakage domain and electrodynamic forces acting on high voltage winding have been calculated. Finite Element Method was used for the magnetic flux density simulation. The electrodynamic force value under the fault exceed significantly the nominal mechanical stresses of the winding.

Key words: 3D magnetic field analysis, electrodynamic forces, mechanical stresses, electric arc fault in windings

1. Introduction

The determination of the electrodynamic forces acting on the HV windings is a very important operation problem, especially in power system transformers and autotransformers. In the spaces between winding turns exists the leakage magnetic flux which acts on the excited wires [2, 5]. The magnetic flux and wire currents cause the electrodynamic forces acting on the conductors, armature and insulation structures of transformers. These forces are very high under short-circuit of the wires. Due to, magnetic interaction between the current-carrying conductors, they can be damaged under the short-circuit [2, 3, 6]. The accidental short-circuit by the electric arc between winding and ground is considered in this paper. For the leakage field area analysis the Finite Element Method (FEM) can be used. In this work the FEM is also employed for 3D magnetic flux density and magnetic force calculation in the windings (coils) of a power autotransformer under the disturbance, mentioned above. Unfortunately, the experimental examination of the forces is nearly unrealizable. Thus, the numerical 3D field analysis has been used by a transformer designer, to determine the force values under short-circuits in the coils [7].

2. Analysed object and fault description

2.1. Analysed object

In this paper a 3-phase power system autotransformer with rated voltages $U_{1N} = 160.12$ kV (for serial windings – HV) and $U_{3N} = 71.1$ kV (for medium voltage – MV) for the common coils was investigated (Fig. 1). Moreover, in these figure is marked attacked the electric arc acting on the turn in the high voltage winding. The nominal currents are equal to $I_{1N} = 464.7$ A and $I_{3N} = 1084.92$ A, respectively. The serial coils were wound with $N_1 = 579$ turns, whereas the secondary side coils have $N_3 = 248$ turns. The transformer windings' connection is presented in Figure 2. The short-circuit I_{1Z} distributions for the HV and MV windings' is depicted.

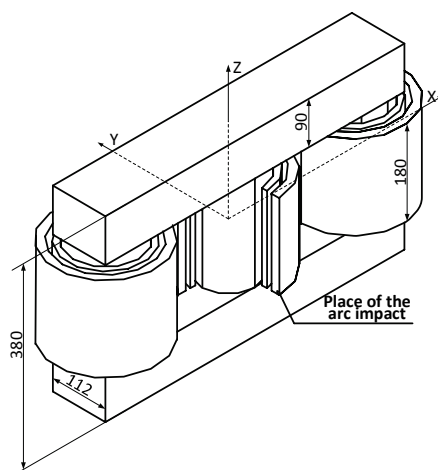

Fig. 1. Main dimensions of the investigated autotransformer (in mm)

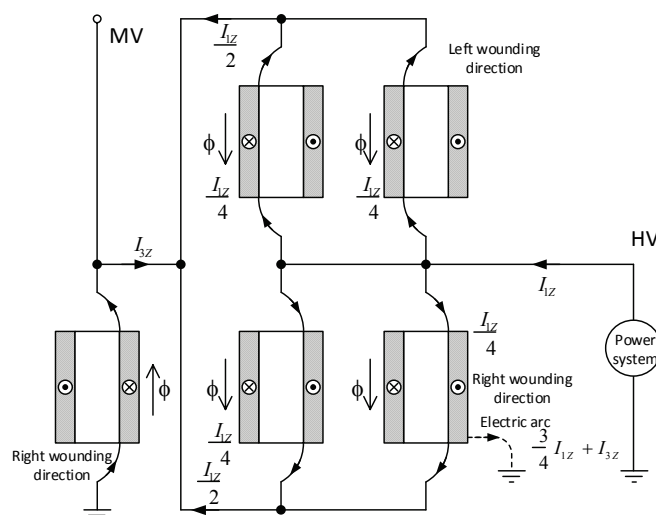

Fig. 2. Diagram of the connections between HV and MV windings with depicting of the short-circuit place

2.2. The fault description

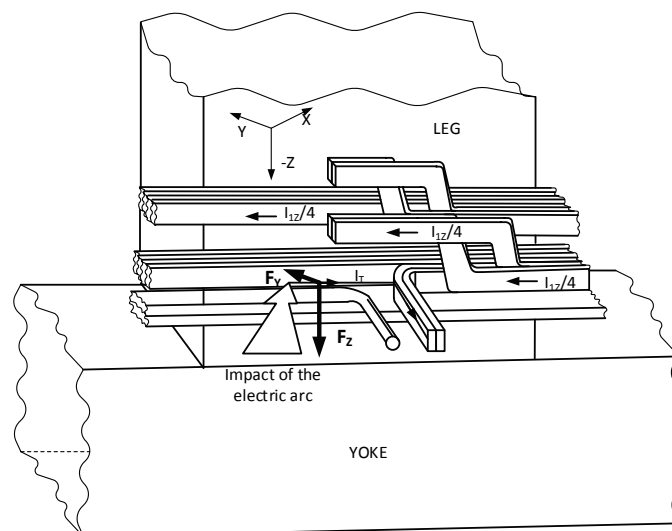

Fig. 3. Topography of the wires and impact place of the electric arc into HV winding



Fig. 4. Deformation of the lower part of the HV winding of the analysed autotransformer

The arc arised between the grounded beam of the core and the terminal of the regulation winding (RW), which linked the high voltage (HV) winding and the middle voltage (MV) one. Considering the topography of the wires (Fig. 3), the electric arc has been impacted into lower wire so called “twin” of the HV winding and got across the ground. Moreover in this picture are presented the occurred electrodynamic forces affected on the attacked wire. The shorted MV winding forced steady state currents as schematically is depicted in Figure 2, where the RW winding is not shown. The current value in the destroyed part of the HV winding was

many times greater than the short-circuit one I_{1z} in the remaining part of the winding. In picture (Fig. 4) is presented the real deformation of the HV winding part. These figure shows, that the surge current of the arc has flowed by the HV winding lower final turn and forced electrodynamic strengths.

3. Numerical model

The calculations are done using a work station with: CPU Alpha 21164 which was run at 533 MHz, Motherboard AlphaPC 164LX, RAM 512 MB. The investigated model is much greater than the area of the fault (one turn in the HV winding). That causes high difficulty in the fine discretization of the calculated region. Thus, in this paper the 3D leakage area concerns one phase (middle column) of the power autotransformer. The finite element grid included a part of the cylinder with plane angle to 3^0 . In spite of the division of the calculated region into the two regions, the used meshes were composed from 300 000 and 215 000 elements for the window and outer (the core) regions, respectively. On the outer faces the “tangential” ($\vec{H} \cdot \vec{n} = 0$) boundary condition was assumed [4]. Due to symmetry of the leg, in the half high of it the “normal” boundary condition was used ($\vec{H} \times \vec{n} = 0$). The view of the finite element grid in the autotransformer window is presented in Figure 5.

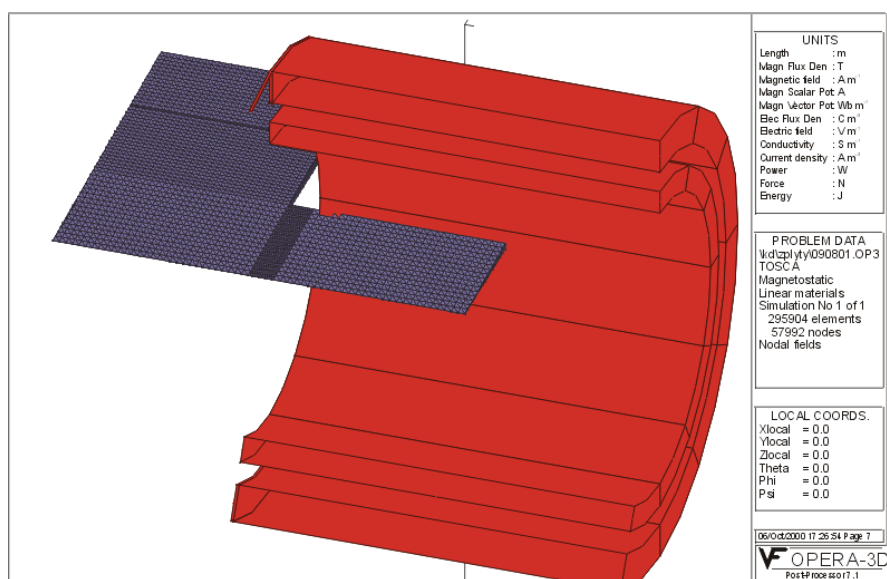

Fig. 5. View of the Finite Element Grid for the window of the power autotransformer

For 3D numerical calculations the commercial package Opera 3D was used. Its algorithm is based on two magnetic scalar potentials combination [1, 4]. The first potential ψ is called the total one while the second potential ϕ is called the reduced one. In the regions without the excited currents the homogeneous elliptic equation has been solved

$$\nabla \cdot (\mu \nabla \psi) = 0. \quad (1)$$

In the current carrying regions, the reduced potential ϕ satisfies equation with the known value of the magnetic intensity due to the excitation currents

$$\nabla \cdot (\mu \nabla \phi) - \nabla \cdot (\mu \vec{H}_S) = 0. \quad (2)$$

In above relation, the magnetic field intensity \vec{H}_S is determined independently from Biot-Savart law

$$\vec{H}_S = \int_V \frac{\vec{J} \times \vec{r}}{r^3} dV. \quad (3)$$

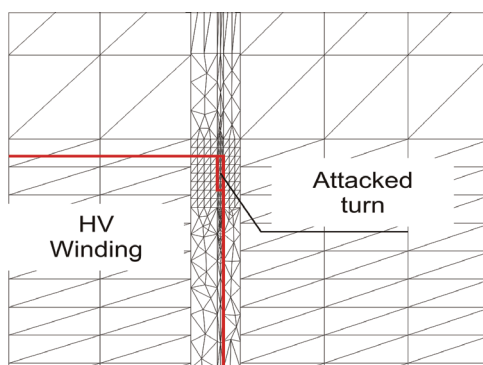

Fig. 6. Refinement of the mesh in the cross section in near area of the damaged turn

4. Calculation results

The execution time of the calculations, for one case, was about 12 minutes. The mechanical strengths arising during the transient state by the electric arc have been calculated. For the analysed object the maximal values of the current in HV and MV windings are $I_{1M} = 9.15$ kA and $I_{3M} = 21.4$ kA, respectively. The assumed current value in the attacked turn was equal to $I_T = 28.6$ kA. Thus, the current densities in the HV and MV windings and attacked turn are $J_{HV} = 18.05$ A/mm², $J_{MV} = 26.34$ A/mm² and $J_T = 1239.86$ A/mm². The direction of the current was opposite to the current density vector in the whole HV winding (Fig. 3).

The real damage was appeared in the outer area of the autotransformer, but in this paper were investigated results of the impact of the electric arc as well as in outer area of the HV (case 1) winding and in the window of the autotransformer (case 2). In Figures 7 and 8 the magnetic field density B_Y and B_Z components spatial distributions are presented inside HV winding, for the case 1. In Figures 9 and 10 are presented the flux density distributions (B_X and B_Z) for the second case. The results concern the attacked winding cross-section which has been depicted as rectangle in each figure.

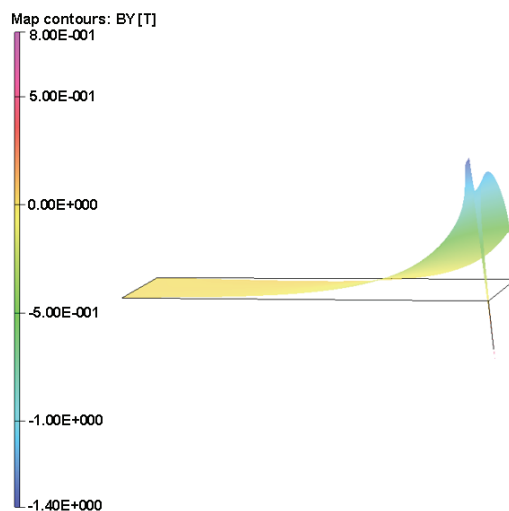

Fig. 7. B_y component distribution inside HV winding for the case 1 (in Tesla)

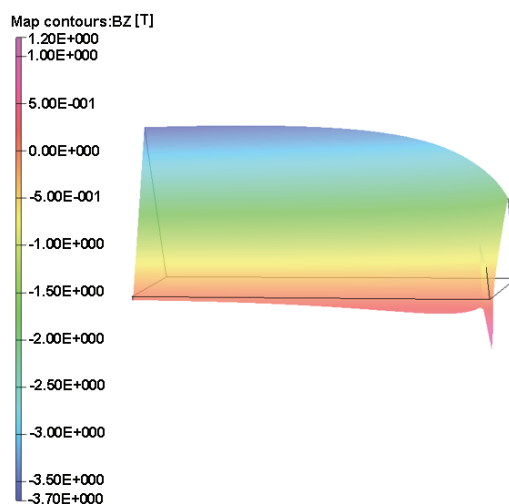

Fig. 8. B_z component distribution inside HV winding for the case 1 (in Tesla)

These figures show, that the investigated fault caused disturbance in spatial distributions near attacked turn only. Because of that fact, the maximal values of the short-circuit current of the windings is assumed in analysed models, the maximal value of the B_z component between MV and HV windings reached 3.5 T. After 3D magnetic field analysis the magnetic flux density \vec{B} , and the unit forces \vec{F} acting on the damaged turn has been calculated using below relationship

$$\vec{F}_l = \int_S (\vec{J} \times \vec{B}) dS. \quad (4)$$

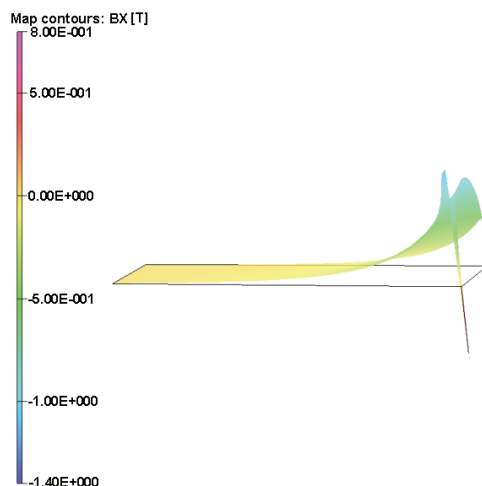

Fig. 9. B_x component distribution inside HV winding in the transformer window (in Tesla)

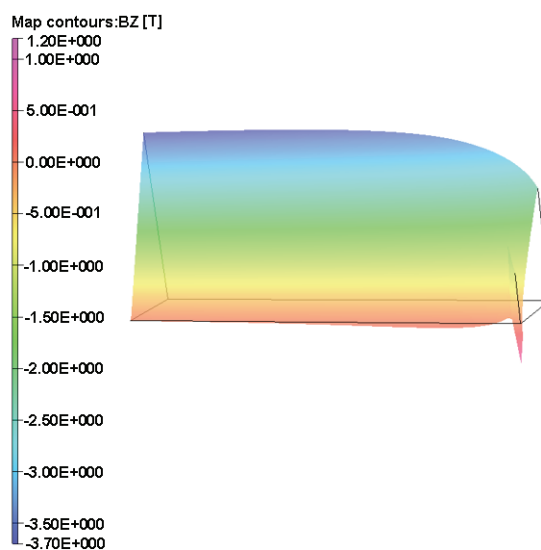

Fig. 10. B_z component distribution inside HV winding in the transformer window (in Tesla)

The obtained values of the magnetic forces acting on the wire length in the transformer window are $F_{YW} = 10556 \text{ N/m}$ and $F_{ZW} = -21968 \text{ N/m}$, while the forces on the wire in the outer region are $F_{XO} = 1722 \text{ N/m}$ and $F_{ZO} = -20551 \text{ N/m}$. The forces cause mechanical stresses (radial $\sigma_{RO} = 5281,6 \text{ N/m}^2$ and axial $\sigma_{AO} = 1736 \text{ N/m}^2$) in the part of the winding with the damaged turn excide many times the permissible value. For the copper wire the value is equal to $\sigma_{AO} = 105 \text{ N/m}^2$. Thus the occurred electrodynamic forces damaged the part of the HV winding.

5. Conclusions

In this paper, the electric arc short-circuit of the HV winding damage in the power auto-transformer was carried out. In the considered case the numerical calculation of the forces was difficult, due to the disproportion between the cross-sections of the attacked turn and the whole winding. The B distributions presented in Figures 5 and 6 confirmed the local disturbance of the leakage magnetic field near the attacked turn. The determined values of the mechanical stresses acting on the attacked turn were many times higher than permissible ones.

References

- [1] Binns K.J., Lawrenson P.J., Trowbridge C.W., *The Analytical and Numerical Solution of Electric and Magnetic Fields*. Chichester, U.K. Wiley (1992).
- [2] Jezierski J., *Transformers*. WNT Warsaw (1983) (in Polish).
- [3] Ye Z.J., Kreischer C., Kulig S.T., *Analysis of Transformer Short Circuit Characteristics Based on 3D Finite Element Method*. IEEE Power Engineering and Automation Conference (2011).
- [4] OPERA Manager User Guide, Vector Fields Ltd., Oxford, U.K. (1999).
- [5] Zakrzewski K. Tomczuk B., *Magnetic field analysis and leakage inductance calculation in current transformers by means of 3-D integral methods*. IEEE Transactions on Magnetics, pp. 1637-1640 (1996).
- [6] Zakrzewski K. Tomczuk B., Koterias D., *Influence of the location of the area fault on magnetic field and forces during special short-circuit an autotransformer*. Scientific Letters of the Silesian University of Technology, Electricity 176: 183-192 (2001)
- [7] Zakrzewski K. Tomczuk B., Koterias D., *Simulation of forces and 3-d field arising during power autotransformer fault due to electric arc in HV winding*. IEEE Transactions on Magnetics, pp. 1153-1156 (2002).