

FEM BASED ANALYSIS

of wing wall to culvert connection

Pavlo Voitenko
 Ph.D. Candidate, Dept. of Civil Engineering
 Auburn University, USA

J. Brian Anderson
 Associate Professor, Department of Civil Engineering
 Auburn University, USA

As part of transportation systems, culverts are subjected to complex load conditions such as earth pressure and traffic live load. The objective of this paper is to study factors that lead to crack formation in the culvert-wing wall connection immediately after construction.

Culverts are a type of hydraulic structures, that are often used in highway infrastructure. A culvert is distinguished from a bridge in that it is fully embedded into the soil (1). Culverts are often advantageous over the short span bridges due to economic feasibility and environmental sustainability, especially in case of low road embankment. They require less construction time and maintenance costs. Nevertheless, the failure of the culvert components may interrupt highway service. Culverts can be classified as arch, box, circular, or masonry (2). Typical materials for culverts are reinforced concrete, corrugated metal, solid-wall and strengthened plastic (3). Wood, cast-

iron, vitrified clay pipe, and stone box culverts were used in the past (4). This article focuses on crack formation in concrete cast-in-place (CIP) culverts. They are preferable to others due to load carrying capacity (wide waterways, deep embankments), high resistance to environmental hazards (such as corrosion or temperature changes during freeze-thaw periods) and low maintenance cost (5). In comparison with precast sections, CIP culverts can be specially designed to meet the specific site requirements.

Wing walls with headwalls are special retaining structures that are commonly used on both sides of the culvert at the waterway opening and

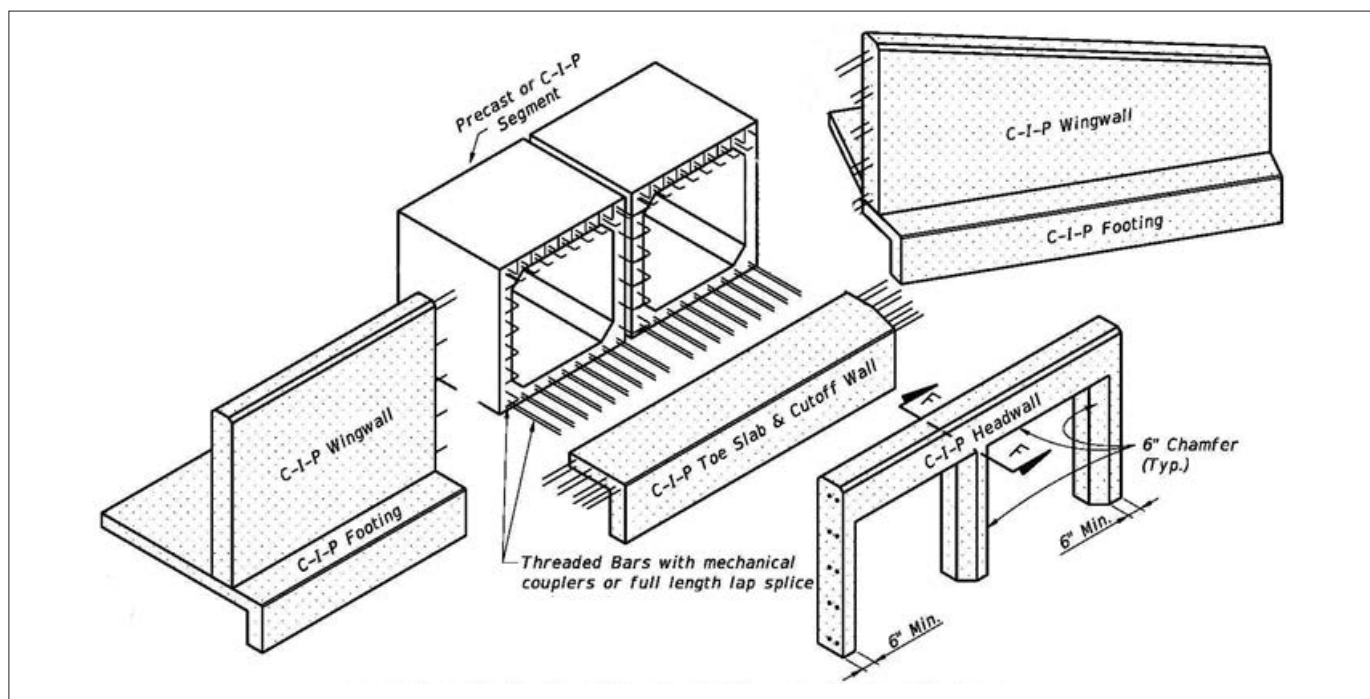

Fig. 1. General plan of the culvert (7).

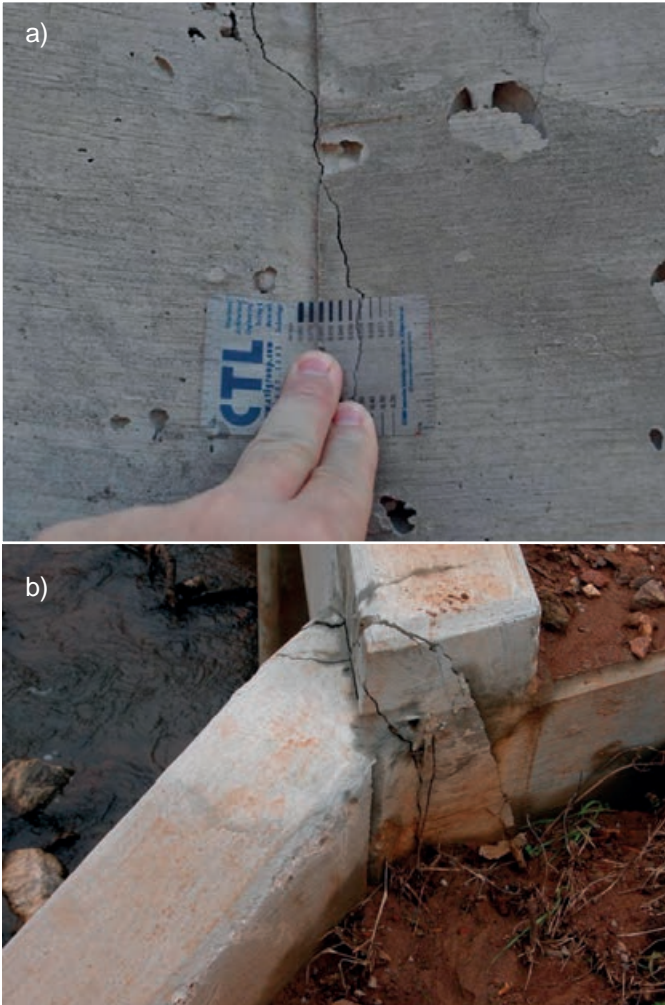

Fig. 2. Culvert distress a) Centerville, AL; b) AL 49 near Dadeville, AL.

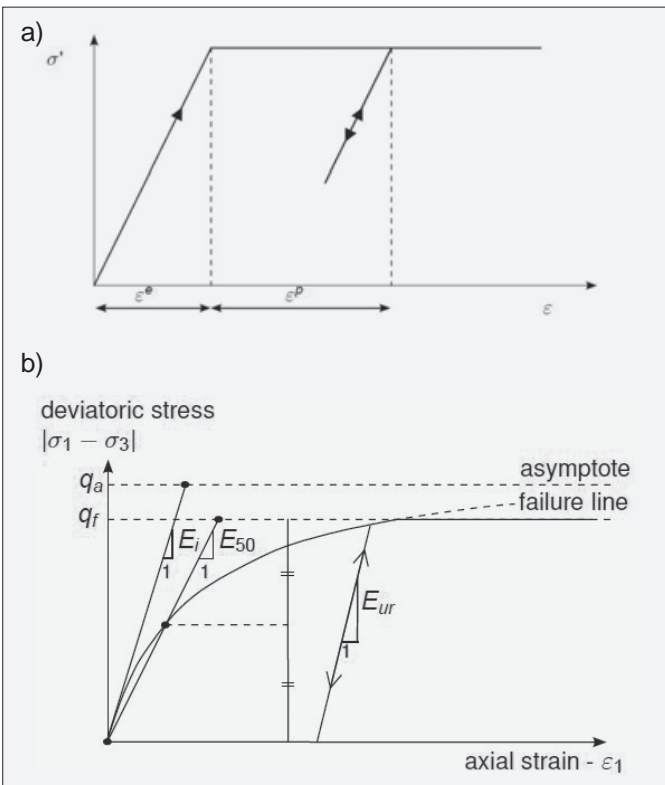

Fig. 3. Elastic perfectly plastic model (a); hyperbolic stress-strain relation (b) (14).

exit. The main purpose of these structures is to hold the backfill from sliding to the entrance and protect the soil from eroding (6). The wing wall is usually cast in place at an angle to resist lateral soil pressure and direct the stream into the culvert. Since ground conditions are unique for each site, specifically designed, CIP wing walls are recommended (5). Wing walls may or may not be attached to the headwall. However, for large culverts, the headwalls and wing walls should always be separated by a structural expansion joint (6).

Box culverts are classified as a special category of bridges if they are 3 m wide in a direction parallel to the roadway (1), and the maximum span length for the single section should not exceed 6 m (5). As bridges, they are subject to cycles of traffic load, hydrostatic pressure (inside and outside), and non-uniform soil pressure. The critical combination of these loads can result in damage or loss of serviceability. Since the underlying soil and backfill may consist of different layered components (various soil types), there is a probability of non-uniform settlement under the applied load (2). Also, these structures constantly deteriorate due to water flow through them and therefore must be designed, constructed and maintained appropriately (2).

Traditional design considers the culvert and wing wall integral as one system with or without (Fig. 1) an expansion control joint (8–10). However, for large culverts, the barrel and the wing walls are designed differently. The barrels are designed following the same code provisions as for bridges (8,10) and the wing walls are designed as cantilever retaining walls to resist out-of-plane backfill pressures (6). Thus, in the case of loosely compacted soil under the culvert or excessive traffic load, differential settlement of the components may result in tensile stresses and cracks all over the wing to culvert connection (Fig. 2).

Problem statement

The problem of cracking along the vertical contraction wing joint in newly built culvert was recently reported in Alabama. The first one, located near Centerville, has cracked after the formwork was removed and before backfill was placed (Fig. 2a). The second, on AL49 near Dadeville, cracked along the wing to culvert connection after construction was completed (Fig. 2b). Non-uniform settlement of the soil base under the culvert and wing wall with inappropriate/inadequate maintenance were indicated as possible reasons for the crack formation rapidly after construction.

The objective of this article is to investigate the stresses and deflection along the culvert to wing wall connection under different load and backfill geometry combinations that may lead to crack formation using 3D FE modeling.

Literature review

In the past years, a large number of culverts were inspected, instrumented, reanalyzed, and rebuilt all over the world.

133 precast culverts were inspected in Ohio state to evaluate durability. Joint leakage was reported as the main issue with the barrels and that there is no connection between damage and the age of the structure.

Musser (12) analyzed the behavior of three-sided precast box culverts based on data collected by Utah DOT. Reports show that 53% of culverts have tension cracks at the bottom slab as well as in the walls. The conclusions were that the ground key and metal straps between sections had a negligible effect due to installation deficiencies, erosion and scours.

Also, a number of studies of the crack formation problem were done using finite element (FE) modeling. One of them focused on research reason of large cracks development in CIP culvert box right after construction (13). To properly analyze the soil, 2D FE model with elastic, inelastic, consolidation and creep components was simulated. It was concluded that the soil settlement produces a “beam like” effect to the whole structure in the direction perpendicular to the traffic.

Most of the research studies were focused on conditions and serviceability of the barrels. The cracking along the wing to culvert connection has generally not been considered.

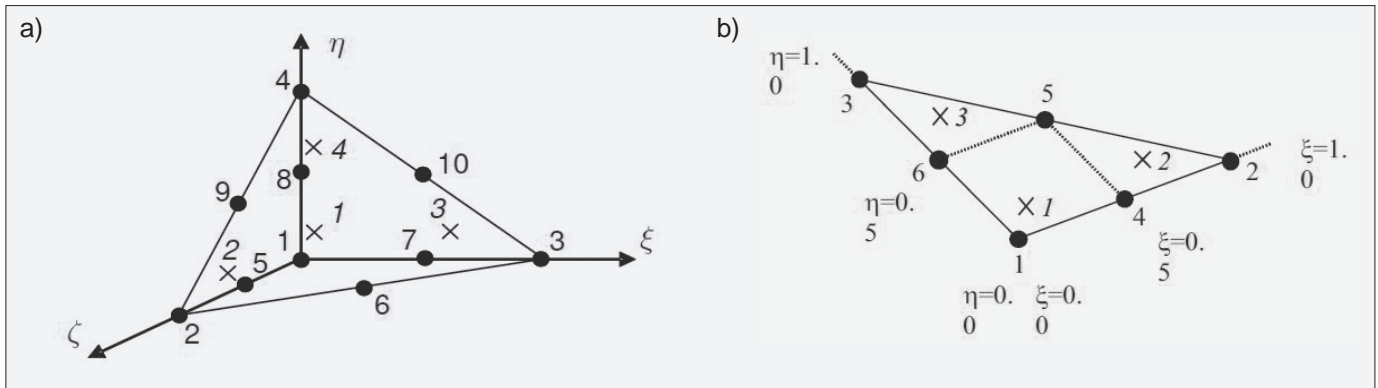

Fig. 4. Local numbering and position of nodes (•) and integration points (x) of: a) 10-node wedge element; b) 6-node plate triangle (17).

Table 1. Material parameters

Layers	Unit weight unsat/sat (kN/m ³)	Modulus of elasticity, (MPa)				Poisson ratio, ν		Friction angle, ϕ (°)	Dilatancy angle, ψ (°)	Cohesion, c (kN/m ²)
		E	E_{50}^{ref}	E_{oed}^{ref}	E_{ur}^{ref}	ν	ν_{ur}			
Mohr-Coulomb										
Backfill	19	68	-	-	-	0.3	-	30	0	6.9
1st layer (0-1.5m)	17/20	20	-	-	-	0.3	-	34	4	6.9
2nd layer (1.5-4.5m)	17/20	40.5	-	-	-	0.3	-	34	4	6.9
3rd layer (4.5-7.6m)	17/20	55.7	-	-	-	0.3	-	34	4	6.9
Hardening Soil										
1st layer (0-1.5 m)	17/20	-	20	16	60	-	0.2	34	4	6.9
2nd layer (1.5-4.5m)	17/20	-	40.5	32	121	-	0.2	34	4	6.9
3rd layer (4.5-7.6m)	17/20	-	55.7	44.5	158	-	0.2	34	4	6.9
Filling material	4		250	250	650		0.3			
Linear-elastic										
Concrete	24	21000					0.2			

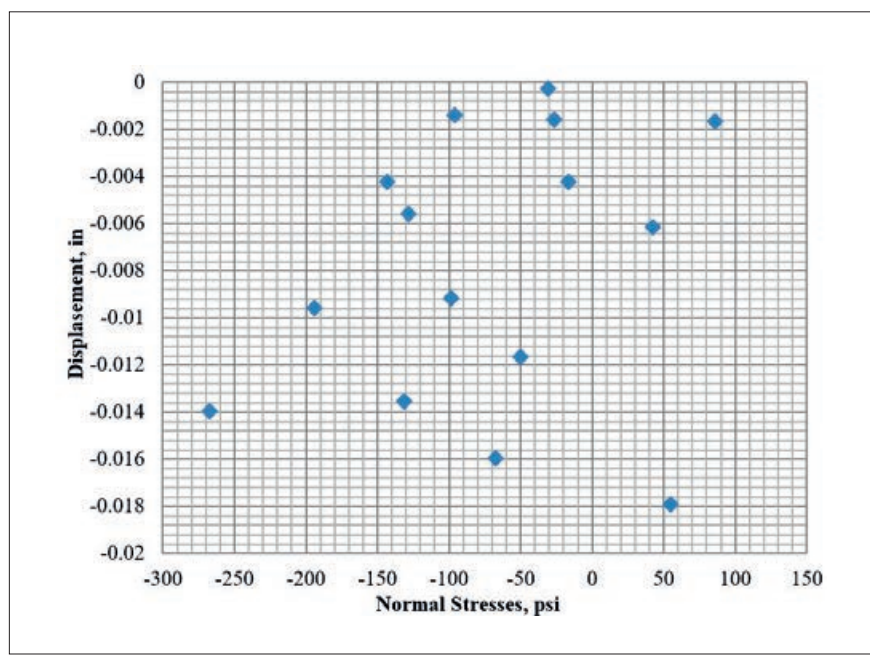

Fig. 6. Stress-displacement relationship in the joint*. *1 psi = 6.89 kN/m²; 1 in. = 25.4 mm

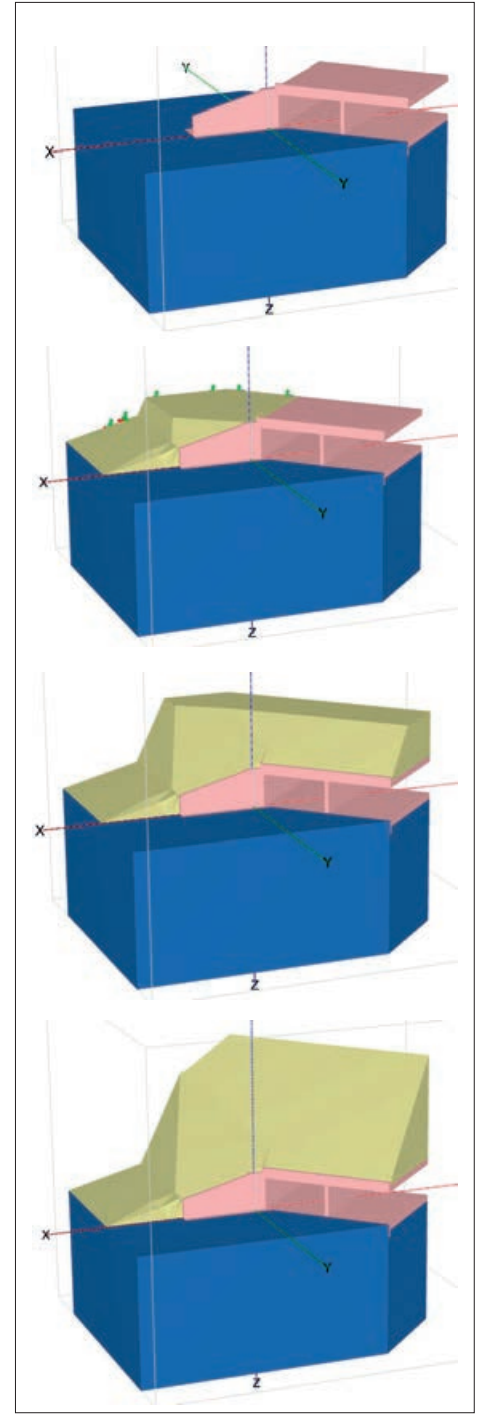

Fig. 5. Backfill construction stages.relationship in the joint*.

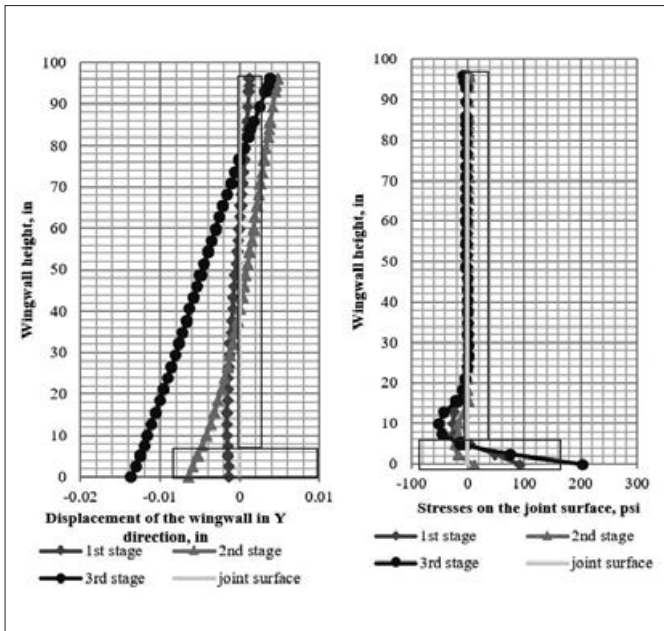

Fig. 7. Displacement and stresses along the joint height**. ** minus sign represent movement forward to the tap

Finite element modeling

Usually, it is difficult to access damaged portions of culverts and properly inspect the cracks and reasons for their formation. Also, full-scale tests are expensive and time-consuming to conduct in order to collect enough data. Thus, FE modeling is an efficient alternative to evaluate this problem.

Plaxis 3D was chosen to simulate the soil structure interaction, since it includes advanced soil material models and allows simple generation of construction stages. Three material models were used in the analysis to investigate the distribution of stresses that cause rapid cracking of the wing to culvert connection. For concrete, a simple linear-elastic model was used. The Mohr-Coulomb (MC) (Fig. 3a) and Hardening Soil (HS) (Fig. 3b) material models were utilized for the soil elements (14).

Material properties of the culvert concrete were determined from the laboratory tests on concrete specimens. For the soil, standard penetration test (SPT) results were correlated with literature (15) to develop model parameters. The material properties are listed in Table 1.

The concrete and soil were modeled using 3D 10-node tetrahedral elements (Fig. 4a) with a second-order interpolation of displacements and 4-point Gaussian integration (16).

The challenging part is to simulate the realistic soil-structure interaction. For this task, 6-node plate triangular interface elements were selected. The main feature of these elements was coupled nodes instead of a single node with zero distance. This element allows slipping and gapping, since after meshing they transformed to 12-node elements with 6-point Gauss integration (17, 18). Additionally, the specific purpose was to prevent stress oscillation close to the corner of the structures.

Wing wall-to-culvert joint finite element modeling

To understand the possible reasons for crack formation, the development of stresses normal to the joint surface was considered. Also, the deformation of the central plane of the joint may help to understand the movement of the structure. To recreate realistic behavior, model was divided into construction stages which included self-weight of materials, backfill, traffic load, and imperfections.

Each model was analyzed for three loading scenarios under service and critical load combinations:

- the behavior of the culvert under backfill load only following 4 main stages (Fig. 5): stage 1 – erecting wing wall and culvert; stage 2, 3, 4 – filling backfill up to 2.1, 4.7 and 7.9 m respectively;

- repeat scenario 1 with filling backfill up to 3.05 m and the fifth stage – distributed traffic load 5.0 kN/m² or the tandem axial load from the HL-93 truck (8);
- the third scenario replicates the first with a weak soil layer under the wing wall to simulate scour conditions.

Results

Results for the culvert with a 3.7 m wing wall height are presented in Fig. 6. Additional observations include:

- in most of the models, the wing wall has a similar trend of movement and stress development (Fig. 7). At the first stage, it tends to stay in design position without much of movement. With increasing backfill height or additional traffic load, the top of the wing wall rotates away from the barrel and the bottom too, creating stress concentration zone up to 2000 kN/m². Normal stresses rapidly decrease from 0.5 m over the footing up to the top of the wall;
- the predominant displacement of the wing wall tends to develop in the Z (vertical) direction. The magnitudes of displacements in other directions are much smaller;
- traffic loading did not affect the structure significantly. The maximum normal stresses in the joint – 689 kN/m²;
- maximum stresses observed in the models with disconnected joint – 621 kN/m², what is much smaller than in rigidly connected (Fig. 5).

References

- [1] Drainage manual. Minnesota department of transportation (MNDOT); 2000.
- [2] Detailed visual culvert inspection guidelines. Main Roads Western Australia; 2012.
- [3] Roadway Plans Preparation Manual: Plans Preparation and Assembly. Alabama Department of Transportation (ALDOT); 2008.
- [4] Coghlan, B. K., Highway bridges and culverts. 1916; Agricultural and Mechanical College of Texas.
- [5] Plans Preparation Manual. Florida Department of Transportation (FDOT); 2011.
- [6] FHWA Structural Design Manual for Improved Inlets & Culverts. U.S. Department of Transportation; 1983.
- [7] FDOT Design Standards. Suppl Details: Precast Concr Box Culvert; 2012.
- [8] AASHTO LRFD Bridge Design Specifications, Customary U.S. Units, 7th Edition; 2014.
- [9] Geotechnical Design Manual. NYSDOT; 2012.
- [10] Culvert Calc, Technical Manual, Automated RCB culvert analysis and design in accordance with the AASHTO LRFD Bridge Design Specifications, 5th Edition. Iowa Department of Transportation; 2013.
- [11] Hurd JO. Field Performance of Precast Reinforced Concrete Box Culverts. Transp Res Rec Transp Res Board; 1991; (1315): 53-7.
- [12] Musser SC. A Synthesis of the Application and Performance of Three-Sided Precast Box Culverts. Transp Res Rec J Transp Res Board; 1995; (951091).
- [13] Ahmed, B., Amanat, K.M., Safiullah, A.M.M., Choudhury, J. R. Causes of cracking of culverts on filled soil and their performance after repair. J Civ Eng; 2003; CE 30(1).
- [14] PLAXIS 3D AE - Material Models Manual. PLAXIS; 2015. Available from: <http://www.plaxis.nl/plaxis3d/manuals/>
- [15] Kulhawy FH, Mayne PW. Manual on Estimating Soil Properties for Foundation Design. Palo Alto, CA: Electric Power Research Institute; 1990; p. 306. Report No.: Report No. EL-6800.
- [16] PLAXIS 3D AE - Reference Manual. PLAXIS; 2015. Available from: <http://www.plaxis.nl/plaxis3d/manuals/>.
- [17] PLAXIS 3D AE - Scientific Manual. PLAXIS; 2015. Available from: <http://www.plaxis.nl/plaxis3d/manuals/>.
- [18] Dunavant DA. High degree efficient symmetrical Gaussian quadrature rules for the triangle. Int J Numer Methods Eng; 1985; Jun 1;21(6):1129-48.

Abstract. As part of transportation systems, culverts are subjected to complex load conditions such as earth pressure and traffic live load. In addition, culverts may experience differential settlement of underlying soils, hydrostatic load, and aggradation/degradation scour. Combinations of these effects may cause crack formation or even structural failure. The objective of this paper is to study factors that lead to crack formation in the culvert-wing wall connection immediately after construction. Finite element models (FE) with Plaxis 3D software were used to analyze the stress distribution along the wing wall connection under different load scenarios and geometries. Mohr-Coulomb (MC) and Hardening soil (HS) non-linear material models were utilized. Tension stresses were occurred at the top of the wing wall as well as out of plane rotation away from the culvert, contributing to cracks as observed in the field.

Keywords: culvert, wing wall, FE analysis, Mohr-Coulomb, Hardening soil, earth pressure, plaxis 3D, non-uniform settlement.