

## **Management of hybrid renewable energy source in smart building with use SCADA system**

Jan Szymenderski, Dorota Typańska  
Poznań University of Technology  
60-965 Poznań, ul. Piotrowo 3a, e-mail: {Jan.Szymenderski;  
Dorota.Typanska}@put.poznan.pl

The paper presents issues concerning the problems of energy management in buildings equipped with building automation systems and renewable energy from different sources. The first part discusses the issues of energy demand in buildings and the problems associated with its volatility during the circadian cycle and also provides an example of a source hybrid PV/T panel, describes its construction and use. Next part is the presentation of building automation systems and management systems. On this basis, it proposed to use the SCADA system and its connection with the installation of building automation as the supervisory software production and energy consumption in a detached house. In conclusion, it demonstrated the advantages of the presented solution, rated the possibility of implementation and benefits to users.

KEYWORDS: Hybrid Renewable Energy Source, Smart Building, SCADA, KNX, PVT

### **1. Introduction**

In the mid 70s of the twentieth century appeared the concept of distributed control systems. This concept from the beginning was mainly used to control industrial processes: petroleum refining, cement manufacturing, power generation, paper, etc. With the development of technologies related with automation and communications expanded to other areas of industrial production, energy management to the automation of buildings or agriculture [3].

The first digitally controlled systems, used in construction began to appear in the 80s and were used to control lighting, temperature, air-conditioning and alarm systems. Currently, building automation systems called intelligent installations are widely accepted and adopted in building (houses, public buildings, apartment complexes and industrial) [3].

Building automation systems relate to improving the interaction between integrated systems and residents / users of buildings. Historically, they have been developed with automatic control systems, HVAC (heating, ventilation, air conditioning), while improving human comfort and lower energy costs [3].

Currently, the most important factor, which stimulates the development of building automation are issues related to energy savings. High frequency energy crises and environmental trends motivate the development of energy management systems [3].

Electricity and heat are the most important types of energy used in buildings. Unfortunately, the use of conventional energy sources means that their consumption is quite a way for the user. The way to reduce costs is to use renewable energy, eg. Via solar panels, photovoltaic panels, wind turbines, biomass, geothermal energy. But in this case there are problems associated with the random character of the availability of renewable energy mainly due to volatility of weather conditions, especially the seasons. This situation makes it impossible to ensure the energy needs of users a day, or year based solely on renewable energy. It becomes necessary so the use of previously used conventional sources [2].

When considering the issue of energy demand for residential building and its users with regard to the use of energy from renewable sources, pay attention to the behaviour of residents and daily energy consumption of the building. For residential buildings the most commonly used renewable energy is solar energy. Installation of solar collectors and photovoltaic cells is relatively simple and the most adapted to the building (roof surface). Unfortunately, due to the daily cycle of energy it is available for only a few dozen hours in the day. Also, weather conditions (rain) strongly affect the ability of solar systems. Unfortunately, users benefit from energy-intensive usually during the morning and evening when it is already available. As for the heat problem it is relatively small because it can be stored in a fairly easy manner. Worse is the case of electricity, the storage is cumbersome. At this point it becomes necessary to apply the appropriate management systems, which allow the maximum use of available resources manner, for example. By the sale of power when it has no demand in the building [2].

Renewable energy conversion systems are focused mainly on one type of energy processed, eg. heat or electricity. The main disadvantage of these sources is the strong dependence of the amount of energy produced by the current weather conditions and climate. From the perspective of the final user is quite troublesome. In this case, a good solution is to use a hybrid sources, for example PV/T (Photovoltaic Thermal Hybrid Solar Collectors), which shown in Figure 1 [1].

The device combines the advantages of a photovoltaic cell with standard solar collector. Standard PV module efficiency decreases when the temperature is increasing. This phenomenon is unfavourable. PV/T modules limit decrease electrical efficiency because the heat is dissipated through the solar panel. This heat has a very good parameters and can therefore be used to keep temperature

of eg. domestic hot water at the appropriate level. This solution significantly improves the economic balance of the entire investment [9].



Fig. 1. Cross-section of the PV/T module [1]

Features of PVT panel [4]:

- integration of the two energy converters in one package,
- two types of energy (heat, electricity),
- better energy conversion efficiency,
- the ability to create cascading systems.

## 2. Management of energy resources

### 2.1. Intelligent building system

The development of electrical engineering, computer science, telecommunications and other fields of engineering caused the spread of digital technology in everyday life. This significantly expanded control capabilities m. AI. of the buildings. The use of sensors, actuators, software and communication techniques enabled the building management from a single location. Newly constructed buildings be equipped with a variety of complex technical systems, which should be appropriately controlled. These include, among others [5]:

- electrical installation,
- installation of fire,
- lighting,
- installation (HVAC. Heating, Ventilation and Air Conditioning)
- installation of access control and surveillance,
- installation of a computer network.

Additionally, an intelligent system consisting of [5]:

- smart sensors;
- a network of PLCs and controllers dedicated;
- HMI Systems (ang. Human Machine Interface);
- SCADA system (called. Supervisory Control And Data Acquisition).

Intelligent building system has virtually unlimited applications. One of the most common types of home automation is the KNX / EIB. It is the world's first

open standard for building management. This approach enables the use of multi-vendor (currently over 300 has in its offer products compatible with KNX / EIB). It is widely used both in single-family houses to large buildings complexes [13].

A necessary condition for the well-being of inhabitants of the building is to maintain adequate thermal comfort. Use in this area of modern building automation solutions and hybrid systems provide both greater comfort and optimal exploitation of the heating system of the object [11].

The most important element of the heating system is to control the temperature. In this chapter will be presented a heating control system " intelligent building KNX. Use of the KNX bus integrated control system allows the user to control the heating in all types of usable buildings. Initially, the intelligent temperature control had the highest use of residential buildings (detached houses, apartment buildings), but at the moment we see a trend, towards public facilities - especially hotels, and to a lesser extent office and schools [11].

KNX installation integrates all the functions of building management. It is used to turn on, control, signalling, regulation and supervision of electrical equipment installed in the building. It replaces the classical electrical installation. The plant automation system based on the power supply circuits are completely separated from control circuits.

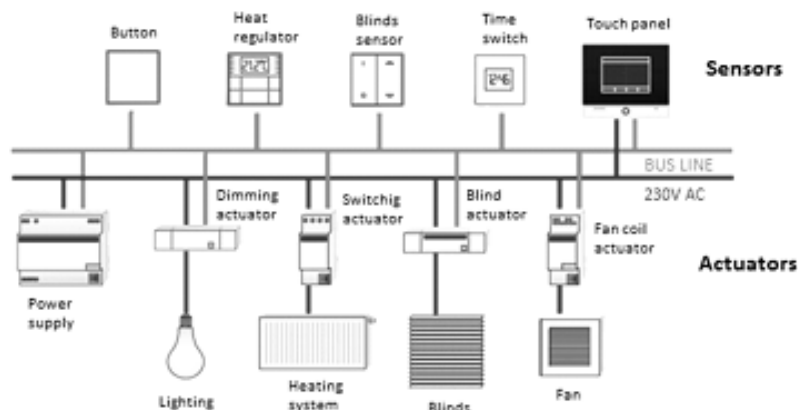

Fig. 2. Scheme of KNX system [14]

The method of interaction of these circuits is determined by the user, what is important to easily allows modification of the scheme action [13]. On Figure 1 shows a schematic KNX intelligent building system.

KNX is a system containing devices performing the heating control. We divide them into two groups [12]:

- Control sensors

– Actuators called actors.

The task of the sensors is to send commands, which are then executed by the actuators, in the form of switch (on / off) valve for full temperature control. In a system is also possible programming the temperature depending on the time of day as well as the presence of members of the room. On Figure 3 shows an example of the sensor and actor manufactured by Hager, which controls the heating system of the building.

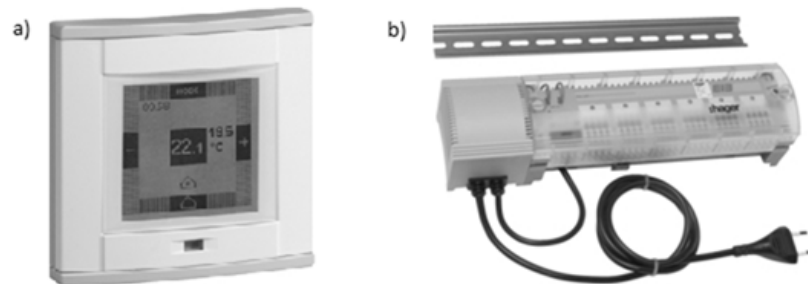

Fig. 3. Control elements the heating system of the building: a) sensor - temperature controller, b) actor - heating controller [7]

An essential element of the heating control system, is regulator. On the basis of the information received from the room placed sensor (measured temperature and the set task) developed a control method radiator valve [9]. On Figure 4 shows a block diagram of the temperature regulation.

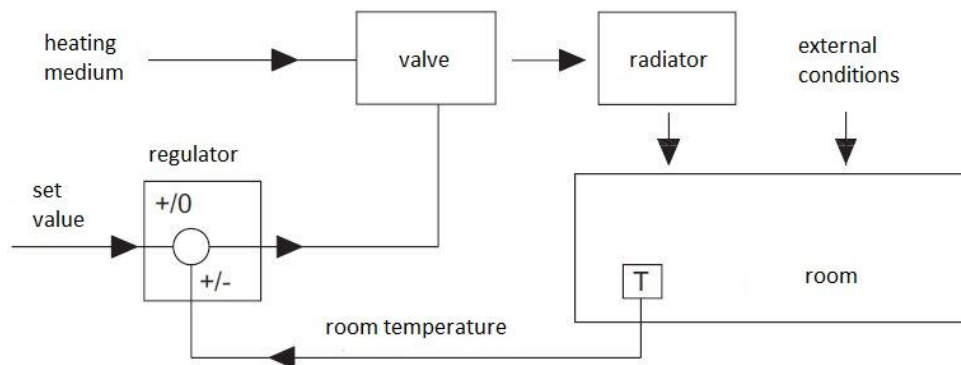

Fig. 4. A block diagram of room temperature control by sensor [8]

## 2.2. SCADA systems

SCADA systems (called. Supervisory Control And Data Acquisition) are mainly used to monitor processes or production. The tasks of the system include:

collecting current data, visualization, archiving, process control and alerting. The software communicates using a protocol of measurement devices and regulations, which are usually Programmable Logic Controllers (PLC called. Programmable Logic Controller). The main application server can be connected via an Ethernet network to other workstations and thereby supervisor manufacturing process has control over its course, and if permitted by the powers possibility of interference in individual stages. The structure of the SCADA system shown in Figure 5 [10].

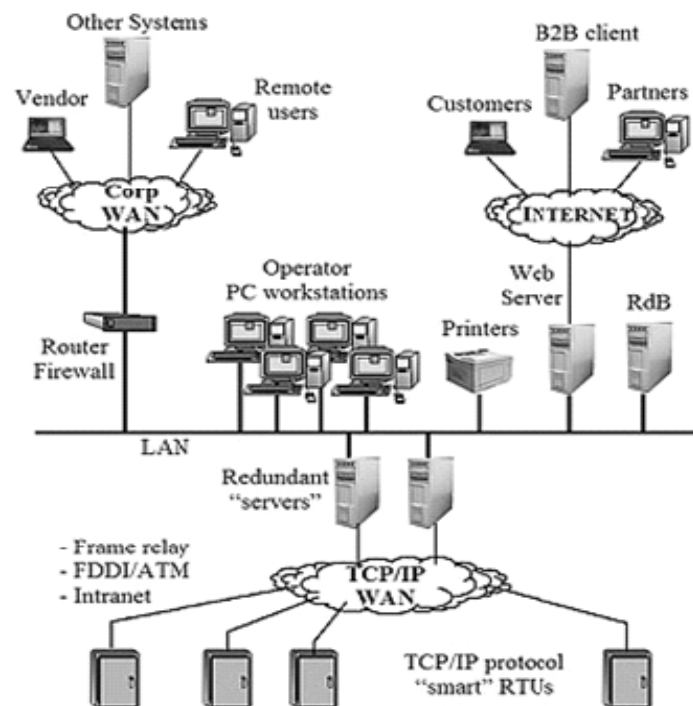

Fig. 5. Diagram of classic SCADA system structure [10]

Figure 6 shows a schematic SCADA system. Its specific tasks include [6]:

- communication with PLCs, dedicated controllers and hubs measurement data,
- processing of process variables by generating balance sheets and calculation immeasurable variables,
- impact on the processes implemented in the intelligent building through manual control work of building devices from the console,
- parent supervision and control of technical installations in the building,
- alarm signalling installations and building automation devices,

- process data archiving and reporting conduct statistical analysis and generation trends,
- graphical and text visualization of devices and systems for synoptic screens,
- support structures algorithmic structures,
- automatic handling repetitive and routine activities,
- forecasting consumables in the building,
- economic management overhaul building automation devices.

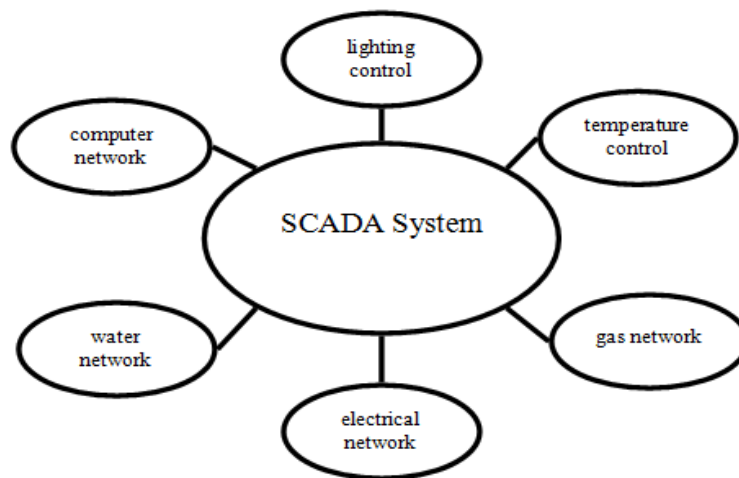

Fig. 6. The block diagram of the SCADA system in the building management system [6]

SCADA systems, thanks to its openness and a wide range of applications, significantly extend the capabilities of oversight installations in the intelligent building [6].

In this paper the installation hybrid model was created consisting of the following elements:

- PV/T solar panel (electrical and thermal energy source),
- hot water tank,
- receiver of heat (heating, domestic hot water),
- circulation pumps,
- electricity storage (battery),
- receiver of electricity (lighting, heating and other electrical).

### **2.3. Implementation of the management program in SCADA system**

Figure 7 shows a model of a managed installation of SCADA level with energy source (PV/T), buffers and receivers.

In order to verify the suitability of the SCADA energy management in residential building, the simulation of the application of this type. It was

decided to use the Vijeo Citect SCADA environment Schneider Electric. It allows the creation from scratch surveillance system with full support various transmission protocols, alarms, reporting, auditing users and their privileges, process visualization and has many other important functions. In order to simplify adopted a universal model renewable energy converters for a detached house, which is a source of heat and electricity in the form of a panel PVT (ang. Photo Voltaic Thermal). Thermal energy is stored in the buffer with heat exchangers and goes into the system of hot water and central heating. While electricity is stored in the battery, used on a regular basis or sold in the preferred user-period. Figure 7 shows a screenshot of the graphical panel preview system devices.

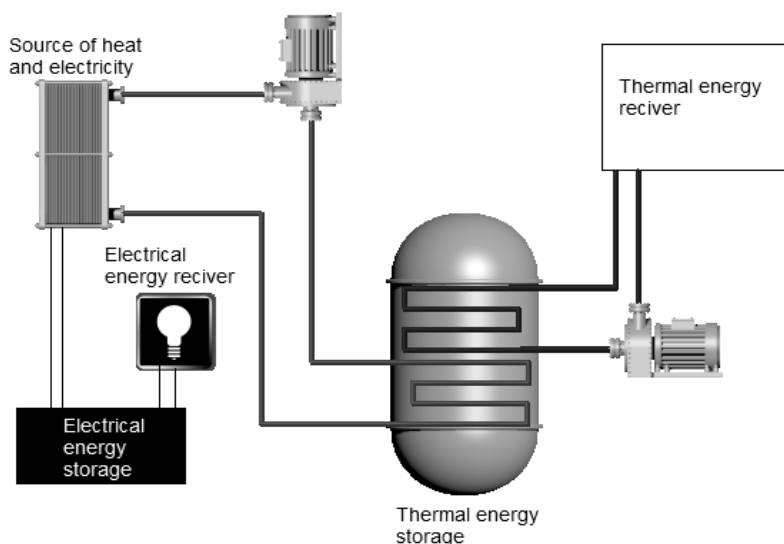

Fig. 7. A simple energy conversion system with a heat and electric buffer visible from the SCADA screen

The model is equipped with the ability to auto simulation. During the operation of the system in test mode, it was possible to ask the load power parameters for different types of energy and the available power from renewable sources. The whole cycle parameters are recorded and monitored for changes on a regular basis. The most significant impact was recorded for the level of electricity use. It worked through the battery to collect it during the presence of strong sunlight and sell at a time when the price was most advantageous. Everything was done automatically based on the entered data. For heat managed to get the right balance to ensure the temperature of hot water at a preset level throughout the day making optimal use of energy from conventional sources.



### **3. Conclusions**

In modern control systems should be aware of the flexibility of such a system. This will help in the future to better fit control systems to the current demand for energy. The presented model can be used to manage more hybrid sources, capable of processing different types of energy.

Energy security and environmental preservation are important both from the point of view of the global economy as well as the average user. To keep this trend cottages residents are trying to use the available energy from renewable sources. It is not as simple as having the equipment itself does not ensure proper operation. Only suitable installation and control software can take full advantage of the applied energy conversion systems. The proposed management system based on SCADA software has many advantages, which include m. In .:

- graphical presentation of the current parameters and system components,
- registration of individual physical quantities for analysis of energy balance,
- implementation of control algorithms depending on the situation at a particular moment of time.
- forecasting based on data collected hypothetical situations that may occur in the building.
- maximize energy use, through proper storage, sale, processing.

These advantages make the use of a SCADA system in a residential building is well founded and can bring its user benefits, particularly economic. Properly managed energy sources also provide support to the electricity system through distributed generation can reduce the load on the main transmission lines and provide assistance in case of failure in the system.

The example implementation of control software allows us to conclude that the introduction of SCADA systems on a wider scale for intelligent buildings is feasible. But it is necessary furnishing adequate infrastructure and equipment installation. The most economical version should be at least one-in PLC and measurement devices provide information about the current state of devices and their parameters.

### **References**

- [1] Alzaabia A. A., Badawiyeha N. K., Hantousha H. O, Hamid A. K.: Electrical/thermal performance of hybrid PV/T system in Sharjah, UAE, “International Journal of Smart Grid and Clean Energy”, vol. 3, no. 4, October 2014.
- [2] Figueiredo J., Martins J. : Energy Production System Management – Renewable energy power supplyintegration with Building Automation System, “Energy Conversion and Management”, nr. 51 (2010).

- [3] Figueiredo J., Sá da Costa J.: A SCADA system for energy management in intelligent buildings, "Energy Conversion and Management", nr. 49 (2012).
- [4] Głuchy D., Kurz D., Trzmiel G.: Photovoltaic thermal as a hybrid form of obtaining energy from solar radiation, "Poznan University of Technology Academic Journals, Electrical Engineering Issue 79", pp 175-180.
- [5] Nowak M., Szymczak A.: Wykorzystanie technologii mobilnych do sterowania instalacjami w inteligentnym budynku, „Napędy i sterowanie”, nr. 12/2011.
- [6] Nowak M., Nowak M.: Rozproszony system SCADA do sterowania i zarządzania instalacjami w inteligentnych budynkach, „Napędy i sterowanie”, nr. 12/2012.
- [7] Product catalog of Hager, 24. 08. 2015.
- [8] Radajewski R., Kamińska A.: The influence of heating control in the KNX installation on building energy efficiency(in Polish), "Elektro- info", no 11/2008.
- [9] Rekha L., Vijayalakshmi M. M., Natarajan E.: Photovoltaic thermal hybrid solar system for residential applications, "International Journal of Research in Engineering and Technology", Volume: 02 Issue: 10 | Oct-2013.
- [10] Schneider Electric: CitectSCADA user guide, October 2010.
- [11] Sowiński K.: Use of the KNX system to control the heating in the building (in Polish), "Elektroinstalator" no 9/2003.
- [12] Typańska D., Jarmuda T.: Improving the energy efficiency of lighting through the use of KNX system, "Przegląd Elektrotechniczny", No 7/2014.
- [13] [http://www.knxpolska.org/info\\_o\\_systemie\\_knx.html](http://www.knxpolska.org/info_o_systemie_knx.html), 24. 08. 2015.
- [14] <http://www.light-and-magic.com/knx.html>, 24. 08. 2015.

*(Received: 30. 09. 2015, revised: 11. 12. 2015)*