

Leszek TOMCZEWSKI*, Jarosław SĘP*

**AN ANALYSIS OF THE INFLUENCE
OF JOURNAL'S HELICAL GROOVE
ON THE WEAR AND LOAD CAPACITY
OF THE SLIDING BEARING**

**ANALIZA WPŁYWU ŚRUBOWEGO ROWKA NA CZOPIE
NA ZUŻYCIE ORAZ NOŚNOŚĆ ŁOŻYSKA ŚLIZGOWEGO**

Key words:

journal bearing, helical groove, load capacity, wear

Słowa kluczowe:

łożysko ślizgowe, śrubowy rowek, nośność, zużycie

Abstract

The article presents the results of a sliding bearing with a helical groove on a journal. The studies included wear tests with contaminated lubrication oil and computer simulation of oil flow based on which the load capacity of a bearing was determined. The 7 bearings with different variants of helical grooves on journal bearings and classical bearings were studied. It was found that the helical groove on the journal makes it possible

* Rzeszow University of Technology, The Faculty of Mechanical Engineering and Aeronautics, al. Powstańców Warszawy 8, 35-959 Rzeszów, Poland, tel. (17)8651512, e-mails: ltktmiop@prz.edu.pl, e-mail: jsztmiop@prz.edu.pl.

to significantly reduce the wear of the bearing in the case of oil contamination with hard particles. It was also shown that the groove on the journal ensures an effective reduction in wear and does not result in a significant reduction of load capacity.

INTRODUCTION

The most common cause of damage to the sliding surface of a bearing is solid particles contained in oil [L. 1, 2, 3]. Studies of this kind of damage are done today, as evidenced by the works [L. 4, 5]. The test results clearly show the increased wear of sliding bearings under the influence of hard particles contained in oil. These particles are rolled, crushed, or driven into the surface layers. In the case of a large difference in hardness between the journal and the sleeve, hard particles of dirt are pushed into the soft sleeve. The recess is not full, and the hard particles projecting from the sleeve damage the rotating journal [L. 6, 7].

One of the design solutions improving properties of bearings is the modification of the shape of the journal through the creation of helical grooves. The developed design solutions of bearings are better than the classic bearings adapted to work in conditions of contaminated oil [L. 8, 9]. Research of [L. 10] sliding bearings with helical grooves lubricated with pure oil indicates that the load capacity of bearing depends on the dimensions of the groove and the spiral pitch of the groove. A groove with a small size increases the load capacity, and if the dimensions of the groove increase, the load capacity is reduced up to 60% of load capacity of the smooth journal. The use of a helical groove arrangement also increases the oil flow by as much as 200%. This may have a positive effect on the bearing performance, because the oil, impurities that cause wear of the bearing will be removed. However, during testing with lubrication oil with hard dirt particles, groove dimensions that are too small slightly increased wear. Therefore, it is necessary to determine the appropriate dimensions of the groove.

This paper presents a compilation of experimental research concerning the wear of bearings with a helical groove on a journal working in contaminated oil from the numerical calculations of the impact of the helical groove on the static characteristics of bearings, which are intended to identify such geometrical parameters of the helical groove, which will have the least effect on the reduction of capacity, while improving the properties and wear of bearings.

METHODOLOGY OF RESEARCH

The study was conducted for bearings with helical grooves. The helical groove was defined by means of two parameters: the spiral pitch of the helical groove

H [mm] and the groove cross-sectional area S_f [mm²]. **Figure 1** shows a general view of the plain bearing and the location of its individual elements.

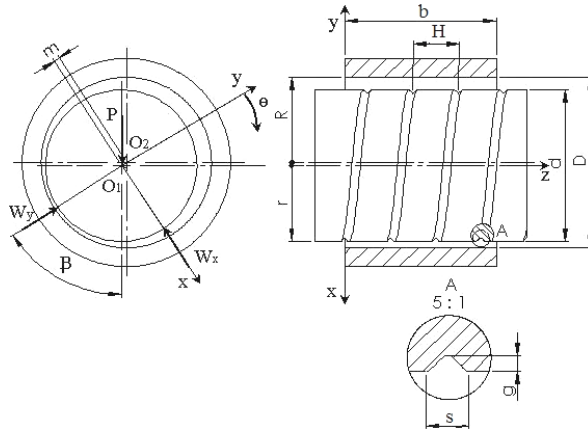

Fig. 1. Sliding bearing with journal and helical groove

Rys. 1. Łożysko ślizgowe z czopem z rowkiem śrubowym

For these parameters, the following values were taken:

- Spiral pitch = 3.5 mm, 11.75 mm, and 20 mm.
- The cross-sectional area of the groove = 0.016 mm², 0.0205 mm², and 0.025 mm².

Research was conducted for the wear of selected bearings and the numerical calculations of the capacity of the bearing.

The wear tests

The wear tests conducted on a tribological ZAN test stand of Gdansk University of Technology [L. 11, 12]. A schematic of the station is shown in **Fig. 2**.

The bearing was investigated in lubrication oil contaminated with hard particles. During the study, the following parameters and operating conditions of the bearing were used:

- Journal material: steel 42CrMo4 with hardness of 52 HRC;
- Sleeve material: MB58 alloy (78% Al, 20% Sn, 1% Cu, 1% Mn);
- Journal diameter $d = 52.7$ mm;
- Bearing width: $b = 30$ mm;
- Relative clearance ratio: $\psi = 0.002$;
- The minimum height of the oil gap: $h_{\min} = 0.017$ mm;
- The rotational speed of journal: $n = 600$ r / min;
- Nominal pressure: $p = 1.57$ MPa;
- Test time: $t = 20$ h (road friction $st = 120000$ m);

- Lubricant: SAE 40: kinematic viscosity of $15 \text{ mm}^2 / \text{s}$;
- Oil contamination: Al_2O_3 powder with a grain diameter of 21 microns; and,
- The concentration of contaminants in the oil: 0.05 g/l, cleanliness according to ISO 4406: 22/20/18.

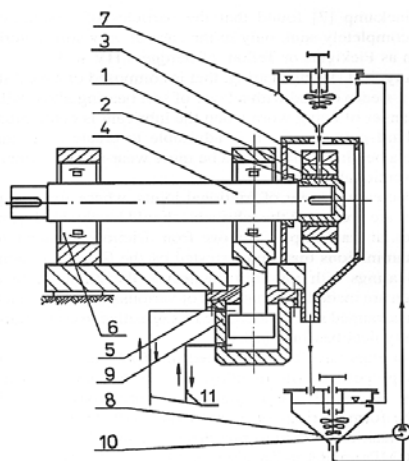

Fig. 2. The scheme of ZAN test stand; 1 – bearing test, 2 – replaceable sleeve, 3 – housing, 4 – shaft, 5 – connecting rod, 6 – shaft, supporting bearing, 7 – upper mixer, 8 – lower mixer, 9 – hydraulic actuator, 10 – rotodynamic pump, 11 – supplying of hydraulic actuator

Rys. 2. Schemat stanowiska ZAN; 1 – badane łożysko, 2 – badany czop, 3 – dzielony korpus, 4 – podpora wału, 5 – stopa korbowodu, 6 – łożysko zewnętrzne, 7 – mieszalnik górny, 8 – mieszalnik dolny, 9 – siłownik hydrauliczny, 10 – pompa wirowa, 11 – siłownik hydrauliczny

The wear of journal was determined from the profilograms of the sliding surface in axial section, where the wear volume was determined. Volumetric intensity of wear of the journal I_{vc} [mm^3/km] was determined as the quotient of wear and friction path.

The load capacity tests

Numerical tests were performed in a MES module using CFD. They consisted of performing calculations and modelling of the slide bearing capacity of the helical groove on the journal. Load tests were carried out for the same parameters as for the wear tests. For the calculations, the following boundary conditions were applied:

- Oil supply:
 - of pressure $p = p_{\text{atm}}$,
 - with a temperature $T = 293 \text{ K}$,

- On the surface of the journal - an appropriate angular velocity ω ,
- On the surfaces of the fixed sleeve $u = v = w = 0$,
- On the sides of the oil film: pressure $p = p_{\text{atm}}$,
- An adiabatic model was used - the heat is entirely discharged by flowing oil.

During the experimental tests, force exerted on the test bearing was used to determine the eccentricity $\varepsilon = 0.76$, for which, according to the accepted boundary conditions, calculations for sliding bearing are performed.

For each of the variants, percentages of the reduction of load with respect to the plain bearings were determined. Then, from the percentages, dimensionless ratio W_1 was determined, which is the ratio of the percentage of load-bearing capacity of the smooth bearing and the percentage of which is a modified load-bearing capacity of the bearing capacity of the smooth bearing.

$$W_1 = \frac{100\%}{W\%} \quad (1)$$

The same procedure was performed for the wear. For each of the variants, the percent increase in the bearing wear of the grooves in relation to the smooth bearing was determined. Then, from the percentages, dimensionless ratio I_{vc1} was determined. Mathematically, this parameter is the ratio of the percentage of wear for the tested variants of bearings and the smallest bearing wear with the groove.

$$I_{vc1} = \frac{I_{vc}\%}{100\%} \quad (2)$$

With two dimensionless parameters, the optimal variant from the point of view of two criteria was determined: the size of the wear and load capacity. The tests were performed in accordance with the method for optimizing multi-criteria referred to as the min-max.

$$\Sigma = |W_1 - 1| + |I_{vc1} - 1| \quad (3)$$

This equation made it possible to determine the optimal parameters of the helical groove arrangement, which cause the least wear of a plain bearing and, at the same time, the least impact on capacity.

TESTS RESULTS AND ANALYSIS

The tests results of wear intensity and the numerical tests of load capacity of the slide bearing with a helical groove are shown in **Table 1**. These values are also presented in a graph (**Fig. 3**).

Table 1. The wear and load capacity summary of the bearing with helical groove

Tabela 1. Zestawienie zużycia i nośności łożyska z rowkiem śrubowym

S_f [mm ²]	H [mm]	W [N]	$W\%$	W_1	I_{vc} [mm ³ /km]	$I_{vc}\%$	I_{vc1}	Σ
0.016	3.5	1604.15	66.26%	1.51	2.45	231.13%	2.31	1.82
0.016	20	2193.22	90.59%	1.10	2.73	257.55%	2.58	1.68
0.0205	11.75	1918.66	79.25%	1.26	1.06	100.00%	1.00	0.26
0.0205	20	2123.35	87.70%	1.14	2.85	268.87%	2.69	1.83
0.025	3.5	1306.29	53.95%	1.85	1.26	118.87%	1.19	1.04
0.025	11.75	1812.72	74.87%	1.34	2.04	192.45%	1.92	1.26
0.025	20	2060.73	85.12%	1.17	1.18	111.32%	1.11	0.29
classic		2421.09	100.00%	1.00	2.45	231.13%	2.31	1.31

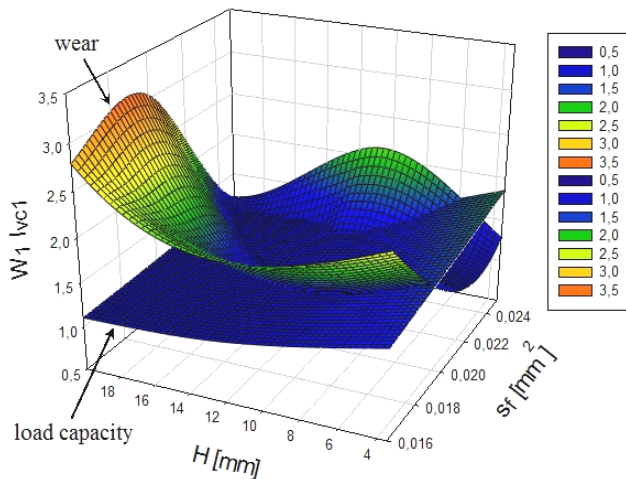

Fig. 3. Diagram of geometrical parameters of a groove load intensity

Rys. 3. Wykres parametrów geometrycznych rowka do nośności i intensywności zużycia

Table 1 and **Figure 1** indicate significant differences in the consumption of sliding bearings and a reduction in load capacity in the studied area. The greatest intensity of consumption occurred in the case of the largest stroke of the spiral pitch in the cross-sectional area $S_f = 0.0205$ mm², and it was greater than that of a smooth bearing. The lowest consumption occurred for pitch

$H = 11.75$ mm, and a surface area $S_f = 0.0205$ mm². The resulting figure is almost two and a half times smaller than for the classic sliding bearing. The results show that the introduction of the helical groove with suitable parameters prolongs the life of slide bearings.

The performed numerical calculations of slide bearings show the biggest change in load capacity occurred next to the groove having the greatest cross-section and the smallest spiral pitch. **Figure 4** shows the pressure distribution in the oil film in the sliding bearing with the chosen geometrical parameters of the helical groove.

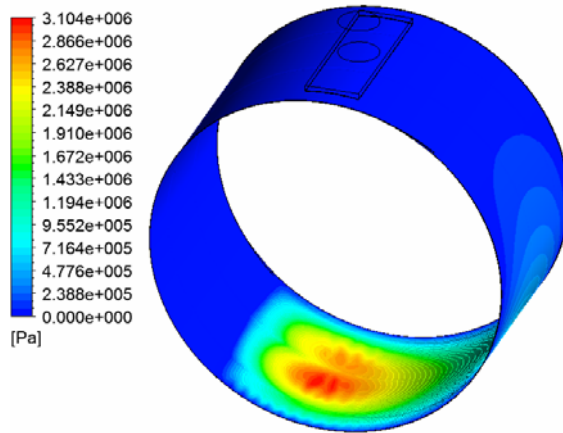

Fig. 4. Distribution of pressure in the oil film bearing with a spiral groove parameters – $S_f = 0.0205$ mm² and $H = 11.75$ mm

Rys. 4. Rozkład ciśnienia w filmie olejowym łożyska ze śrubowym rowkiem o parametrach $S_f = 0,0205$ mm² oraz $H = 11,75$ mm

Load capacity was reduced by 46% using a spiral groove, compared to the classical bearing. The smallest change in load capacity is observed with the groove of the smallest cross-sectional area and the biggest stroke (9.5%). Using dimensionless coefficients W_1 and I_{vc1} , optimal groove perimeters were determined by means of a multi-criteria optimization method. Optimal parameters of a spiral groove are $S_f = 0.0205$ mm² and $H = 11.75$ mm.

CONCLUSIONS

1. The results show that the use of a helical groove reduces wear on the journal when oil is contaminated with hard particles. It is caused by more effective removal of pollutants by the lubricating oil exiting the slot faster.

2. The introduction of the helical groove on the journal causes a reduction in pressure in the oil film, which decreases the load capacity in the analysed variants up to 46%.
3. The smallest negative effect on the load capacity, and at the same time, reduced wear can be seen in the case of a helical groove with a cross-sectional area $S_f = 0.0205 \text{ mm}^2$ and a spiral pitch $H = 11.75 \text{ mm}$.

REFERENCES

1. Sęp J.: Zużycie łożyskowań ślizgowych ze zmodyfikowaną konstrukcją czopa w przypadku zanieczyszczenia oleju cząstkami ściernymi. Tribologia: Tarcie, Zużycie, Smarowanie. Nr 6, 2011, s. 201–209.
2. Sęp J.: Właściwości filmu olejowego w poprzecznych łożyskach ślizgowych z nietypową geometrią czopa. Politechnika Rzeszowska, Rzeszów 2006.
3. Sikora J.: Studia nad metodyką badania wytrzymałości zmęczeniowej łożysk ślizgowych poprzecznych. Zeszyty Naukowe Politechniki Gdańskiej, nr 534, Mechanika, z. 74, Gdańsk 1996.
4. Duchowski J.K., Zitt R., Omlor B.: Effects of contaminants on performance and wear of journal bearings operating under hydrodynamic regime: theoretical experimental and applied considerations. 10th EDF/Prime workshop: „Condition Monitoring, Performance and Safe Operation of Bearings”, Futuroscope, 6–7.10.2011.
5. Koszela W., Dzierwa A., Gałda L., Pawlus P.: Experimental investigation of oil pockets effect on abrasive wear resistance. Tribology International, Vol. 46, 2012, pp. 145–153.
6. Dwyer-Joyce R.S., Sayler R.S., Ionides E.: An investigation into the mechanisms of three-body abrasive. Wear, Vol. 175, 1994, pp. 133–142.
7. Pascovici M.D., Khonsari M.M.: Scuffing failure of hydrodynamic bearings due to an abrasive contaminant partially penetrated in the bearing over-layer. Transactions of the ASME, Journal Tribology, Vol. 123, 2001, pp. 430–433.
8. Lawrowski Z.: Łożyska ślizgowe historia, stan obecny, perspektywy rozwoju. Tribologia: Tarcie, Zużycie, Smarowanie. Nr 6, 2007, s. 7–61.
9. Sęp J., Pawlus P., Gałda L.: The effect of helical groove geometry on journal abrasive wear. Archives of civil and mechanical engineering Vol. 13, 2013, pp. 150–157.
10. Sęp J., Tomczewski L.: Nośność i odporność na zużycie łożysk ślizgowych ze śrubowym rowkiem na czopie. Tribologia: Tarcie, Zużycie, Smarowanie, nr 3, 2012, s. 175–184.
11. Sęp J.: Łożyskowania ślizgowe z nietypową konstrukcją współpracujących elementów, Radom 2013.
12. Sęp J.: Possibilities of sliding bearings properties modification by non-typical journal application. Archives of civil and mechanical engineering Vol. 13, 2013, pp. 168–174.

Streszczenie

W artykule przedstawiono wyniki badań łożyska ślizgowego ze śrubowym rowkiem na czopie. Przeprowadzone badania obejmowały testy zużyciowe przy smarowaniu olejem zanieczyszczonym oraz komputerową symulację przepływu, na podstawie której wyznaczono nośność łożyska. Przebadano 7 łożyskowań z różnymi wariantami śrubowego rowka na czopie oraz łożysko klasyczne. Stwierdzono, że śrubowy rowek na czopie daje możliwość znacznego zmniejszenia zużycia układu łożyskowego w przypadku zanieczyszczenia oleju twardymi cząstkami. Wykazano również, że rowek na czopie zapewniający efektywne zmniejszenie zużycia nie skutkuje znaczącym zmniejszeniem nośności łożyska.

