

*LESZEK OSIECKI* \*, *PIOTR PATROSZ* \*\*, *BETTINA LANDVOGT* \*\*\*, *JANUSZ PIECHNA* \*\*\*, *TOMASZ ZAWISTOWSKI* \*\*\*\*, *BARTEK ŻYLIŃSKI* \*\*\*\*\*

## SIMULATION OF FLUID STRUCTURE INTERACTION IN A NOVEL DESIGN OF HIGH PRESSURE AXIAL PISTON HYDRAULIC PUMP

A novel type of an axial, piston-driven high pressure hydraulic pump with variable capacity marks a significant improvement in the area of the hydraulic machinery design. Total discharge from hydrostatic forces eliminates a need for a servomechanism, thus simplifying operation, reducing weight and introducing the possibility of the pump displacement control by computer. PWK-type pumps, invented in the Gdansk University of Technology, offer high efficiency for pressure levels up to 55 MPa, ability to work self sucking even at high speed. However, the heart of the new invention, the commutation unit, creates harmful pressure peaks. Those peaks can be mitigated by the introduction of a compensation chamber with elastic walls. Owing to the dynamic character of events taking place in the pump, a need for computer simulation arose in order to understand phenomena leading to the occurrence of pressure peaks and choose compensation chamber parameters accordingly. A CFD package alone would not be sufficient to reliably represent the interaction between the compensation chamber wall and the working fluid. This paper presents Fluid Structure Interaction approach comparing 3 different models: 2 simplified models of the pump and a full pump model.

---

\* *Gdansk University of Technology, ul. Narutowicza 11/12, 80-233 Gdansk, Poland; E-mail: losiecki@pg.gda.pl*

\*\* *Gdansk University of Technology, ul. Narutowicza 11/12, 80-233 Gdansk, Poland; E-mail: piotr.patrosz@pg.gda.pl*

\*\*\* *Fraunhofer Institute for Algorithms and Scientific Computing SCAI, Schloss Birlinghoven, 53754 Sankt Augustin, Germany; E-mail: bettina.landvogt@scai.fraunhofer.de*

\*\*\*\* *Warsaw University of Technology, Institute of Aeronautics and Applied Mechanics, Nowowiejska 24, 00-665 Warszawa, Poland; E-mail: jpie@meil.pw.edu.pl*

\*\*\*\*\* *Space Research Center of the Polish Academy of Sciences, ul. Bartycza 18a, 00-716 Warszawa, Poland; E-mail: tomasz.zawistowski@cbk.waw.pl*

\*\*\*\*\* *Rolls Royce Marine, Norway; E-mail: Bartlomiej.Zylinski@Rolls-Royce.com*

## 1. Introduction

### 1.1. PWK pumps

Axial pumps with cam-driven commutation units – the so-called PWK pumps – emerged as a result of a research project conducted in the Department of Hydraulics and Pneumatics at the Gdansk University of Technology.

As for all axial hydraulic piston pumps, several cylindrical working chambers are positioned around the rotating shaft of the pump. The rotation of the shaft and the attached swash plate leads to the reciprocal movement of the pistons which decreases and increases the fluid volume of the chambers alternately. A window – which is a part of the control sleeve or the



Fig. 1. Constant displacement pumps PWK-78 (top) and PWK-27

commutating bushing – connects alternately the chamber between the piston faces with low and high pressure channels.

The main elements of the pump are shown in Fig. 2. The axial piston pumps with constant displacement show a very good performance with a working pressure of up to 55 MPa, an overall efficiency of 94% and good power density.

Although the pistons of the PWK pump always travel the same distance inside the cylinder chamber, the pump's overall displacement may be controlled by changing the angular position of the control cam in relation to the pump's shaft. As both parts are rotating fast, a special planetary gearbox, which ensures precise control over the displacement in the operating range, was developed. Thanks to hydrostatic discharge, such a mechanism requires low input energy and can be driven by a stepping motor. This is the major advantage of the newly developed pumps over all other variable displacement pumps, controlled with complicated hydraulic servomechanisms. It reduces

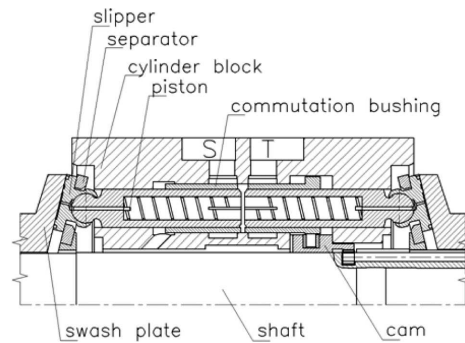

Fig. 2. Main elements of PWK pump. Cross section of one chamber, the shaft and steering elements

the pump's cost and dimension significantly, thereby simplifying the whole process chain.

## 1.2. State of the Art

Among many types of pumps used in modern systems of hydrostatic drive and control the axial pumps are regarded to be the leading design. This is because they are capable of reaching the highest working pressure up to 40-45MPa, highest overall efficiency -90-95% and thanks to their high speed, pumps of that type can deliver more than 1m<sup>3</sup> of fluid per minute. Tilting the swash plate or cylinder block makes it possible to control steplessly their displacement.

However despite a century of development, axial pumps still have some disadvantages. One of them is hydrostatic unbalance of their commutation unit. The higher is pump's working pressure, the higher forces act between its main parts. That results in reduced torque efficiency and high energy consumption by the displacement control mechanism. Flow controllers used in modern axial pumps are heavy, expensive and complicated [2].

Axial pumps with cam-driven commutation units – the so-called PWK pumps – emerged as a result of a research project conducted in the Department of Hydraulics and Pneumatics at the Gdansk University of Technology. Their unique feature is a full discharge of pump commutation unit from hydrostatic forces.

The PWK pump is a new development. Different features of the pump need to be investigated using prototypes and numerical simulation. The experimental results need to be compared with the results of the numerical simulation. With a validated simulation model, different configurations of the new pump can be tested without expensive experimental testing.

Numerical simulation is used in a wide range of applications during different phases of the product development today. It plays an important role

in the development process. However, the results of the simulation are only useful when the simulation models are realistic enough to provide a good comparison with experimental results.

The behaviour of the PWK pump depends on the hydraulic oil and on the mechanical and structural movement and deformations of the pump. Because the movement of the oil and the deformation of certain parts of the pump influence each other, a realistic model of the pump has to incorporate a fluid-structure interaction between the CFD simulation for the oil and the FEA simulation for the pump deformation.

Although numerical simulation is very common in the product development cycle, fluid-structure interactions with moving boundaries and heavy or even incompressible fluids are still a very challenging task. Different simulation codes and the coupling software need to work together to solve a complicated – and in many cases – diverging problem.

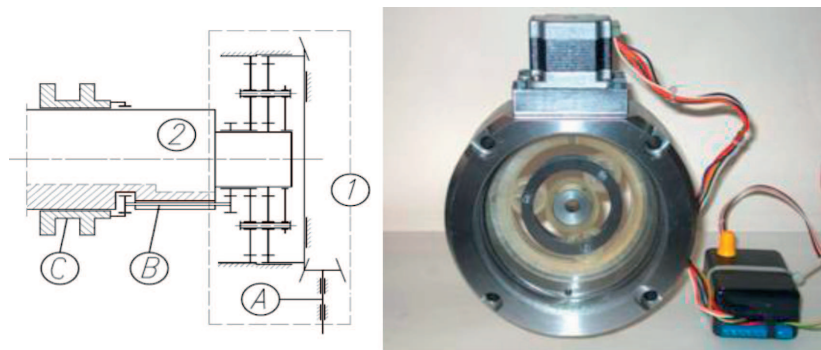

Fig. 3. Displacement control mechanism driven by stepping motor. 1. gearbox 2. shaft

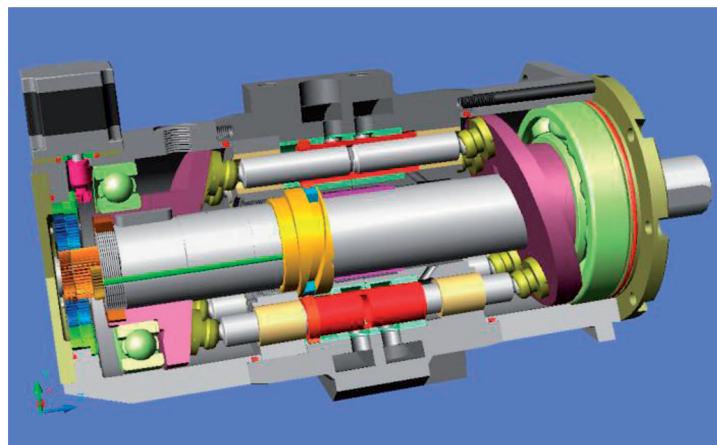

Fig. 4. Variable displacement pump with a visible cross-section through the working chamber

## 2. Pressure Peaks and their Compensation

### 2.1. Pressure Peaks

First tests of the control mechanism for the variable displacement pump confirmed the feasibility of the concept. However, harmful pressure peaks in the cylinder chambers were observed when the cylinder chamber is disconnected from the inlet and the outlet channel. The pressure reaches very high values – 20 MPa above the average pressure in the chamber – for a short time (cf. Fig. 5).

These peaks are influenced by many different factors. The most important ones are the displacement adjustment, the rotational speed and leakage. When the displacement of the pump is decreased, the pressure peaks increase. This is due to the higher velocity of the pistons when the chamber is disconnected from the intake and outtake channels. A higher rotational speed of the shaft also leads to higher pressure peak values; mainly because it reduces the effect of leakage. Oil leakage reduces the amount of fluid to be compressed and thereby decreases pressure peak value. For fast rotating pumps, the piston movement is fast – shortening the time during which the fluid is compressed and reducing the influence of leakage. This increases the pressure peak values.

The compressibility of the hydraulic oil is directly connected with the occurring leakage and thereby it plays an important role in the investigation of pressure peaks. Leakage is influenced significantly by the pressure of the fluid. The gaps in the pump through which small amounts of fluid can leave the pump get considerably larger during the pressure increase. This aggravates the leakage which in turn influences the pressure – resulting in a very complicated feedback.

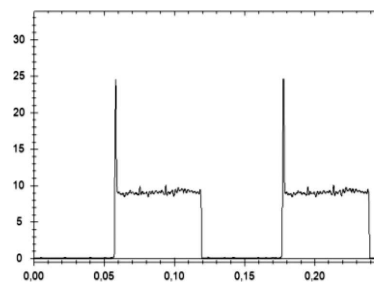

Fig. 5. Pressure variation in pump's chamber (rotational speed 500 rpm, oil temperature 33°, displacement adjustment 20%)(counter-clockwise cam turn)

An equation – using the pumping pressure, the volume of the chambers and the compressibility modulus of the fluid – to estimate the pressure peak value is presented in [3]. The real volume of fluid that has to be compressed

– which is directly linked to the amount of leakage – can be integrated into the equation. This paper does not cover the model with oil leakage.

The different factors contributing to the pressure peak amplitude have been investigated in detail in [3].

## 2.2. Pressure Peak Compensation

The pressure peaks of up to 20 MPa could damage the pump and produce a lot of noise. To get a more robust pump these pressure peaks need to be compensated.

The peaks occur when the working chamber is simultaneously disconnected from the intake and outtake channels and the fluid is compressed. To shorten the period of disconnection from the channels and to give the fluid more room an additional compensation chamber with an elastic wall was introduced. The cylinder chamber connects to the compensation chamber when it is disconnected from the pump's main channels [4].

In the phase of compression (which can be seen in Fig. 6a), the compensation chamber is connected to the fluid volume in the cylinder: the surplus fluid can flow into the compensation chamber which results in a reduction of the pressure peaks. When the pistons move back, thus increasing the volume of the working chamber which fill in with low pressure fluid, the compensation chamber again connects to the cylinder and the fluid can flow back from the compensation chamber to the expanding working chamber, thus averaging pressure in all chambers (cf. Fig. 6b).

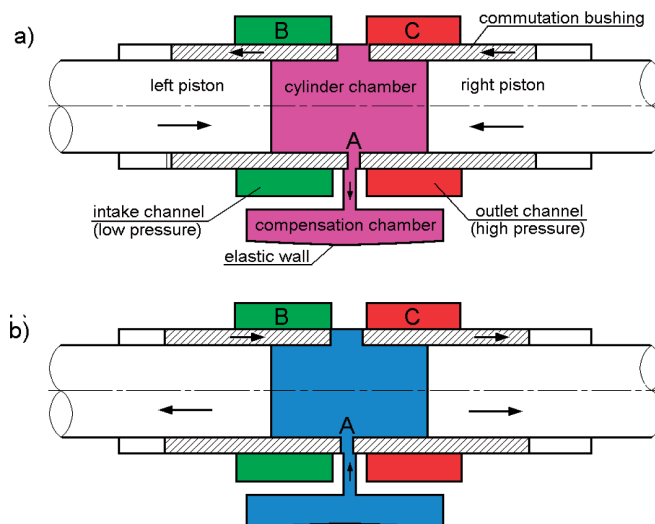

Fig. 6. Pressure peak compensation with a compensation chamber with an elastic wall. a) shows high pressure in the cylinder chamber which causes the fluid to flow into the compensation chamber. In b) the pistons are moving outwards and the fluid flows back in

As the successive cylindrical chambers compress (in most cases seven, nine or eleven cylinder chambers are used) in an alternating cycle, one compensation chamber can be used for all cylinders.

First experimental tests showed that the introduction of the compensation chamber reduced the pressure peak value by 50% without decreasing the efficiency of the pump.

The main objective of the interdisciplinary numerical simulation is to find the optimal layout of the compensation chamber. Differences in shape, elasticity and volume and their effect on the pressure peak values are to be investigated. CFD models of the pump and FEA models of the elastic compensation chamber are developed.

### 3. Computer simulation

#### 3.1. Task Definition

Simulation was conducted on a model of the hydraulic pump, making use of a coupled CFD-FEA analysis.

Its goal was to choose the optimal configuration of the pump's most recent feature, namely the compensation chamber and its relief passages. The compensation chamber was introduced in order to damp pressure peaks occurring in working chambers as a result of inlet-outlet pressure switching by a fast moving commutating bushing. Dynamic phenomena occurring in the critical areas of the pump, like pressure relief passages, are impossible to register in ways other than the computer simulation. The following example shows the advantage of using a simulation approach in the process of searching for optimal behaviour of the pump.

Detailed description of the analyzed configuration is given in Table 1.

Since CFD analysis alone is not sufficient to take into account the response of the structure forming the pump and its components, the CFD computations were coupled with FEA calculations. MPCCI module from Fraunhofer Institute was combined with ANSYS/FLUENT and ABAQUS/FLUENT packages in order to provide a link between CFD and FEA packages and find a solution to the problem defined as Fluid Structure Interaction. The pump was equipped with a pressure compensation chamber formed by a bushing with a flexible wall 1 mm thick. As the excess of oil compressed to high pressure was released through relief passages to the compensation chamber its volume was increasing and the membrane was subjected to deformations, which effected the nodal position of fluid cells in the chamber. Those phenomena were captured through the Fluid Structure Interaction analysis.

Results of the analysis show stress and deflection of the compensation membrane in each test case, as well as the pressure levels with and without the interaction between oil and the membrane.

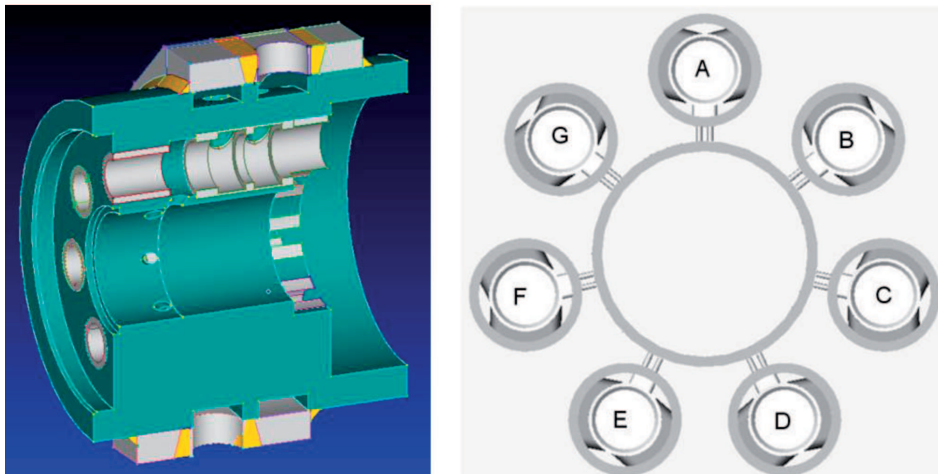

Fig. 7. Cross section through the pump body showing half of the pump body without pistons (left) and the location of all 7 pressure chambers around the perimeter of the compensation chamber (right)

### 3.2. CFD Model Description

The body of the pump is of cylindrical shape with 7 pressure chambers located around the perimeter of the body (see Figure 1).

Each chamber contains a pair of pistons and a commutative bushing. The commutative bushing has through slots positioned around a circumference of the cylindrical bushing, which connect the working chamber with either low or high pressure areas. The bushing, free to move axially and controlled by a cam serves as a pressure valve, alternately connecting low and high pressure ports with the working chamber, depending on the piston work cycle (see Fig. 2).

In the course of previously conducted research, it was discovered that fast switching of pressure level provoked dynamic phenomena in the pump. In order to mitigate them, a compensation chamber was introduced. It is in the form of a cylindrical pocket formed by a bushing, which was press fit at the extreme ends along its axis into a pump body. The compensation chamber cavity linked all working chambers around the perimeter of the pump's inner hole by means of relief passages. Their geometry has impact on the proper operation of the pump.



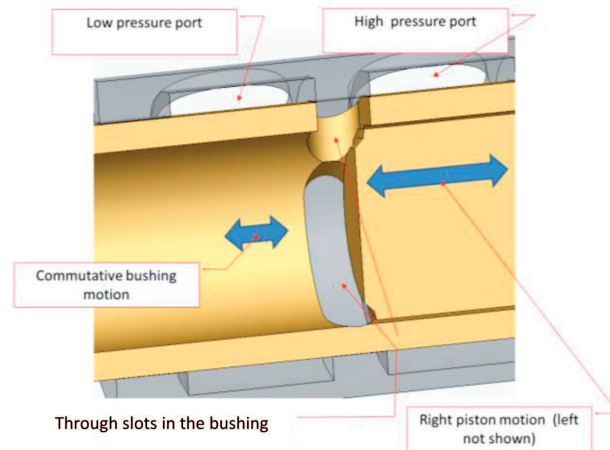

Fig. 8. Commutative bushing and its components

Testing configuration of relief passages was the task of the simulation described herein.

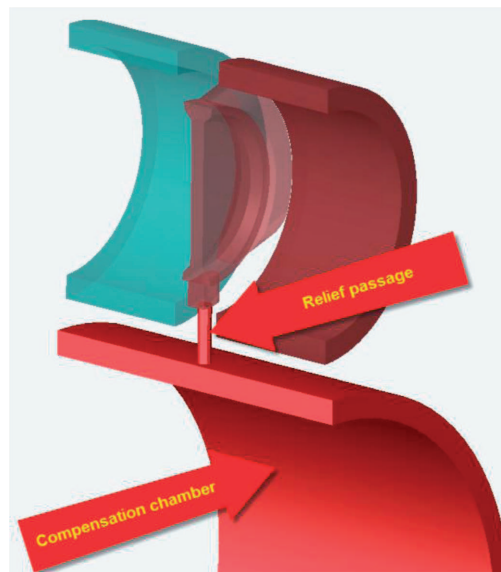

Fig. 9. Relieve passage and the compensation chamber shown on the upper half of model geometry

Since CFD model could become overly cumbersome and difficult to analyze because of its size, instead of constructing a full model of the pump, a simplification was made to create a rudimentary pump model. It would consist of 2 pairs of chambers (top and bottom), with a compensation chamber serving as pressure equalizer. Pistons of the bottom chamber were shifted in

phase with respect to those in the upper chamber by  $3/7$  of a full cycle to simulate the real situation in a fully modelled pump. To further save calculation time, only a symmetric half of the simplified 2-chamber model was used. Similarly, the volume of fluid corresponding to a connecting windows serving as a valve in a commutative bushing was positioned accordingly, both in upper and lower chambers.

The CAD model geometry of the pump was based on the set of construction drawings in order to reflect current changes in the pump topology. Subsequently, a “negative” volume was created: all voids in the CAD model were filled with material and transferred to the CFD package to act as fluid to be analyzed. The top chamber model would simulate the beginning of the work cycle: the pistons would be in the innermost position and the commutative bushing would be centred under the bridge between low and high pressure ports. The bottom chamber would be geometrically located at 180 degrees with respect to the top chamber, but as far as the work cycle goes, it would be phased out by  $3/7$  of the full revolution in order to convey the phenomena that take place in the interaction between two most-phased-out chambers (like A and D in Fig. 1).

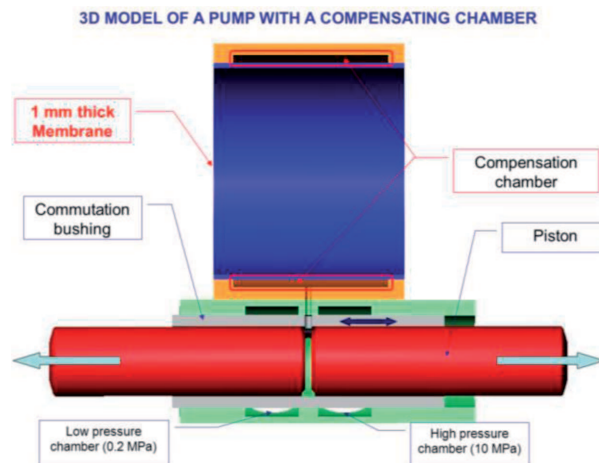

Fig. 10. CAD rendering of major components of the model (upper chamber not shown)

Due to the phase shift, only single pump chamber is connected with compensation chamber in time. After set up and boundary condition introduction, the fluid models were prepared for CFD analysis.

The majority of components were meshed with hexagonal elements, specifically the ones that had motion imposed on them.

There were several models built for different pump configurations. Some of them with coarser mesh, some with refined mesh, taking advantage of available computer power, which was needed to conduct parallel compu-

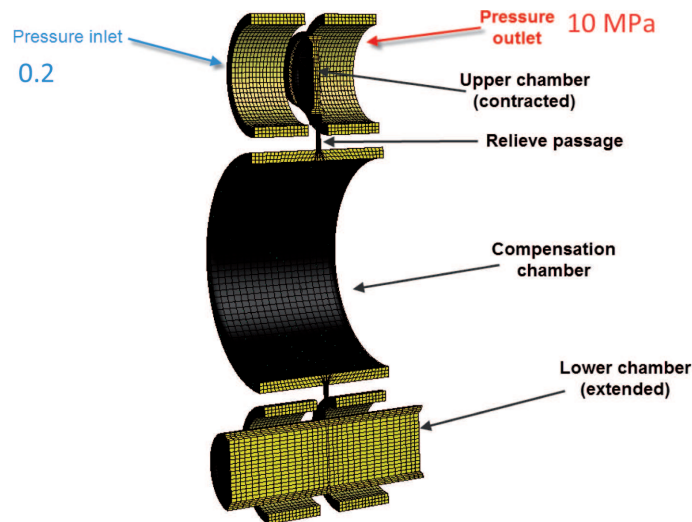

Fig. 11. CFD model – 2 chamber model showing model topology. Their working cycle was out of phase by  $154^\circ$

tations. Figure 4 shows a STAR CCM+ model constructed at the SCAI Fraunhofer Institute.

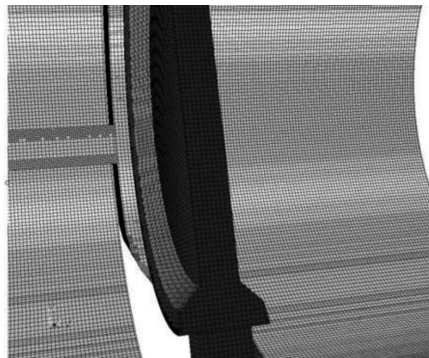

Fig. 12. Refined mesh of the upper working chamber and its related components

### 3.3. Model properties

Coarse models used in analysis conducted in FLUENT, described below featured 23283 cells, 79896 faces and 28085 nodes. They were intentionally crude in order to cut on calculation time.

The solver was pressured-based, coupled and unsteady. It used Spalart-Allmaras 1 equation model of turbulence to take advantage of wall distance correcting functions, because the mesh resolution was not sufficiently fine.

The material was hydraulic oil, made slightly compressible with density described by User Defined Function, which made it dependent on pressure, thus assuming slight compressibility of fluid.

$$E = dp/(d\rho/\rho) \quad (1)$$

where

$d\rho$  = differential change in density of the object

$\rho$  = initial density of the object

Dynamic viscosity ( $\mu$ ) of hydraulic oil was assumed to be 0.044 Pa · s.

Speed of sound was user-defined

$$c = (1. - dp/BMODULUS) * \text{sqrt}(BMODULUS/\rho_{ref}) \quad (2)$$

**Boundary conditions:** inlet pressure was set at 0.2 MPa, while outlet pressure was equal to 10 MPa.

**Mesh motion:** Mesh Dynamic Motion feature was used in Fluent calculations. That allowed movement of the pistons and the commutative bushing to be defined and realized. Mesh of moving elements was layered: the growing mesh would be added to already existing layers, while contracting mesh would eliminate layers in front of the moving external layer of the mesh.

The motion of the commutative bushing was described by the following equation:

$$vel[0] = (-5./1000) * 157.08 * \cos(157.08 * time) \quad (3)$$

which gives the max speed of .78 m/s

$$vel[0] = (-12.59/1000) * 157.08 * \sin(157.08 * time) \quad (4)$$

which results in the max speed of about 2 m/s

Initial conditions: the pressure inlet was set at 0.2 MPa, while pressure outlet was set at 10 MPa. Also 10 MPa was originally applied to the compensation chamber

### Test configuration

The test configuration is described below in Table 1.

Table 1.

Two of six pump configurations that were simulated in the FSI analysis

Model type	No. of relieve holes	Diameter [mm]	Membrane thickness [mm]
Configuration 1	1	1	1
Configuration 5	2	1.4	1

The simulation focused on two different topologies of relief holes. In configuration 1, there was one centrally located hole defined, with 1 mm diameter. In configuration 5 two 1.4 mm diameter holes were used. The purpose of the analysis was to show the behaviour of fluid in each case and suggest the preferable configuration.

Below the examples of configuration no.5 are shown in 2 different formats: design sketch and its implementation in the symmetric model. In Figure 7, which shows a symmetric half of the 2-chamber fluid model, only one relief passage was shown, owing to the symmetry of the model.

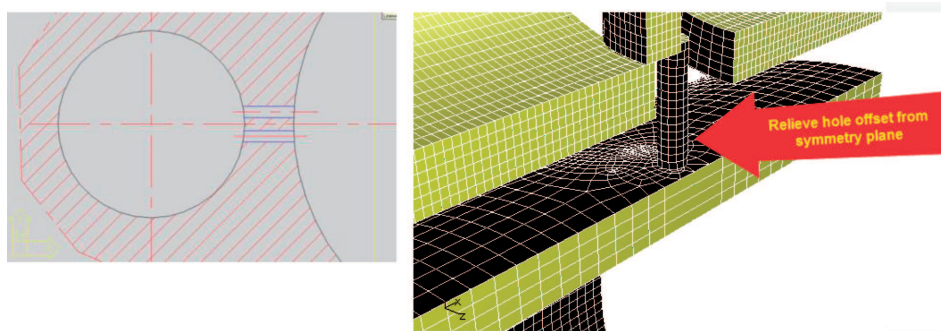

Fig. 13. Configuration no. 5 of the CFD model (note the offset of the hole from symmetry plane)

#### 4. Analysis results

The model created for configuration no.1 consisted of two working chambers, upper and lower, connected with the compensation cavity through 2 relief holes, 1 at the top and the other at the bottom. The compensation chamber was bounded by a 1 mm-thick membrane.

During the initial phase of piston expansion, the lower chamber created negative pressure peak, which could not be equalized by overpressure from the compensation chamber because of the bottle neck created by too small relief hole area (Figure 6). Since there was no cavitation capability built into the CFD model, negative spikes could be visible on the lower chamber pressure plot.

Configuration no.5 model differed from configuration no. 1 in two features: a) there was an extra relief hole connecting the compensation chamber with each working chamber; b) the diameter of each relief hole was increased from 1 mm to 1.4 mm. Thus, the throughput area between the compensation chamber and each of working chambers increased 4 times, from around  $3 \text{ mm}^2$  to  $12 \text{ mm}^2$ .

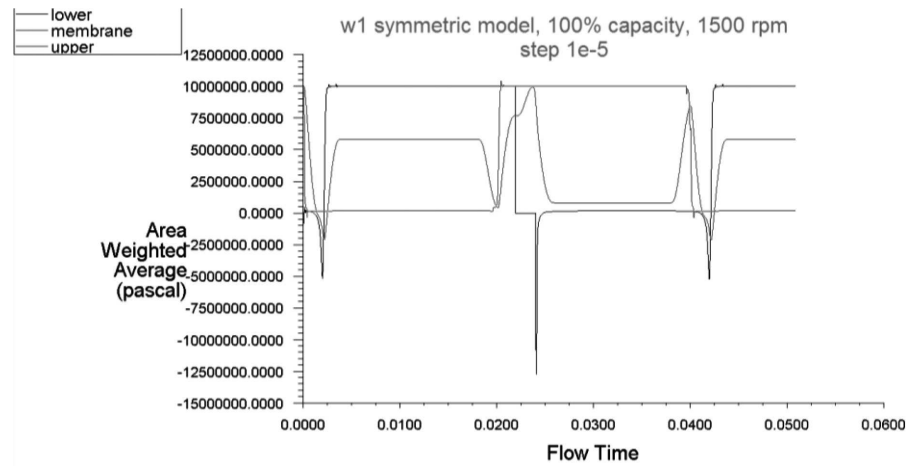

Fig. 14. Plot of pressure in the lower, upper and compensation chambers of the 2-chamber model, configuration 1 (1 relieve hole, 1 mm diameter)

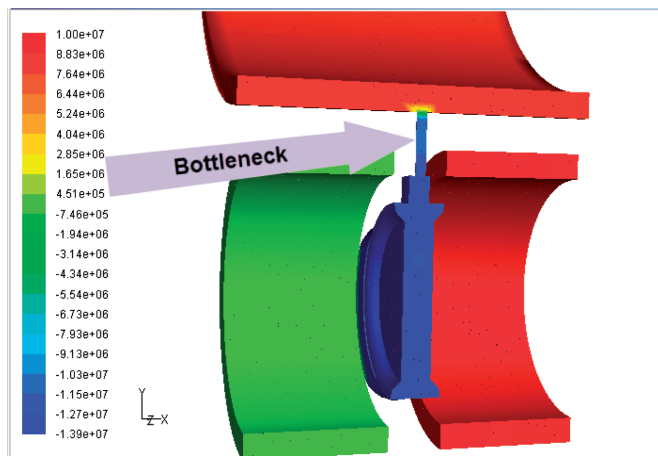

Fig. 15. The reason for negative pressure drop in the lower chamber is the bottleneck created by the relief hole

Pressure plot in Figure 10 compared to the one in Figure 8 exhibits more stable membrane behaviour. Additionally, it shows no negative pressure spikes in either working chamber.

2-chamber symmetric model of the pump is by definition a simplification of the full model. It has an advantage of smaller size offering shorter analysis runs. Nevertheless, it is a good idea to compare such simplified models to a model of a full pump.

Two complete models of the pump were created, one for configuration w1 and the other for configuration w5. The model size of the full pump

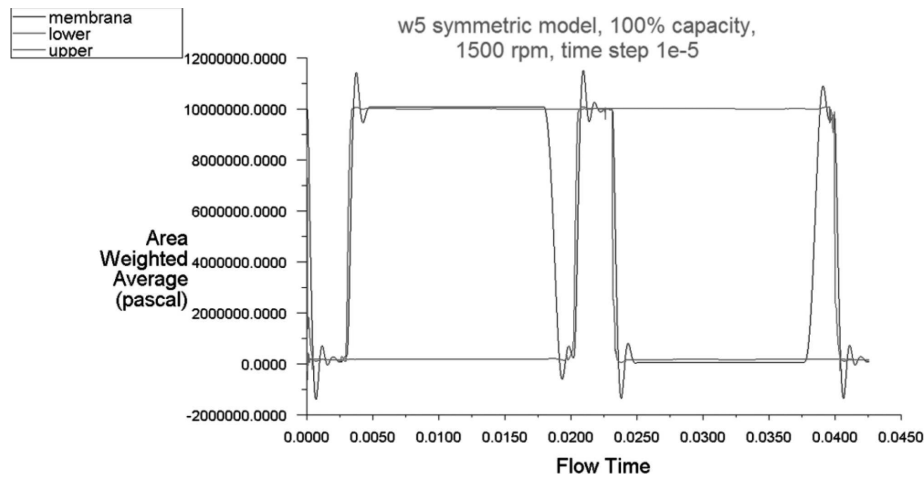

Fig. 16. Pressure plot of configuration 5 model

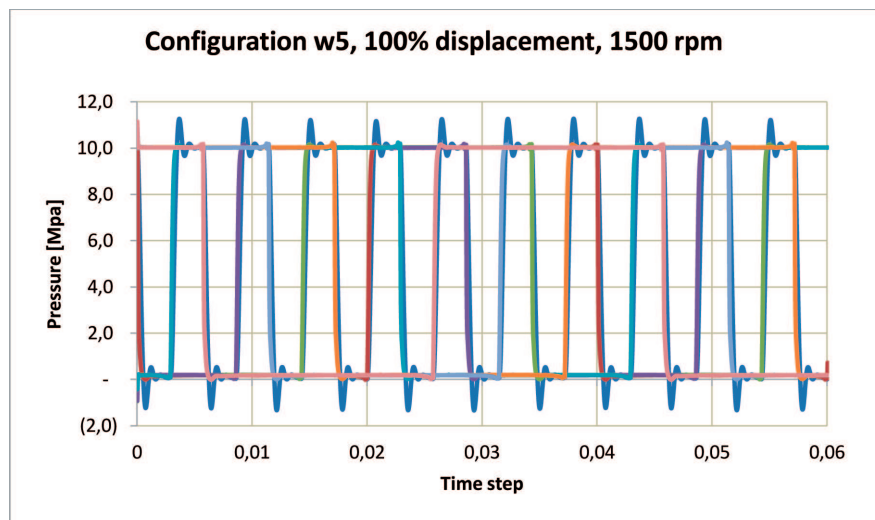

Fig. 17. Pressure plot in working chambers with the compensation chamber pressure (in blue) superimposed. Configuration w5 – full pump

increased considerably: the number of nodes in the full model equalled to 185000, compared to 46000 in a symmetric 2-chamber model.

Owing to high sensitivity of the model to minute discrepancies in positioning of pistons and commutative bushings, all the movable elements were placed accurately, in their respective positions at the beginning of the cycle, based on Excel calculations of motion of each element. Volumes of fluid filling the voids between pistons were meshed in the pre-processor. The appropriate positioning of the elements resulted in repeatable and identical behaviour of each working chamber.

## 5. Conclusion from CFD analysis

The comparison of plots showing the pressure distribution in both models favoured the solution offered by configuration 5, namely 2 relief holes connecting each working chamber to the compensation chamber. Substantially increased hole area eliminated the flow resistance and resulting negative pressure peaks in the relief holes.

Full, 7-chamber model of the pump confirmed trends visible in the simplified, 2-chamber model and proved that for quick, “rule of thumb”-like calculations a simplified model could be used.

However, the CFD analysis described above, concentrated exclusively on the behaviour of the fluid. It did not take into account the response of the membrane bounding the compensation chamber to the loading from pressurized oil and the resulting oil reaction to it.

Such fluid-structure interaction between the confined volume of oil and the flexible bushing forming the compensation chamber wall is described in the FSI section that follows.

## 6. FSI analysis

A Fluid Structure Interaction analysis was set up to compare the results of fluid pressure in two models: one with a rigid membrane and the other with the flexible membrane. Subsequently, the appropriate model was to be selected. The FSI run involved ABAQUS, FLUENT and MPCCI from the Fraunhofer Institute which served as an interface between two separate analysis codes (Figure 18).

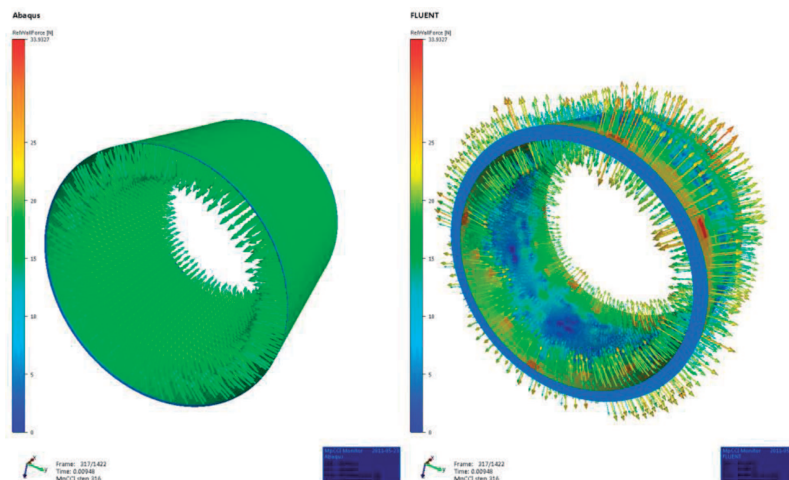

Fig. 18. MPCCI visualizer, interaction of membrane (left) and fluid in the compensation chamber (right). Configuration w5 – full pump



An interaction between a membrane (1 mm thick, elastic steel material) and fluid in the compensation chamber was analyzed. In the coupled FSI analysis, the fluid load was transmitted to the corresponding nodes of the finite element model (Fig. 18), while displacements calculated therein were transmitted back to FLUENT. Finite element model of the membrane consisted of either shell (ABAQUS type S4) or solid (ABAQUS type C3D8R) elements. In the model built with shell models, both ends of the membrane were totally restrained (and additionally a symmetry condition was imposed in the case of a half model).

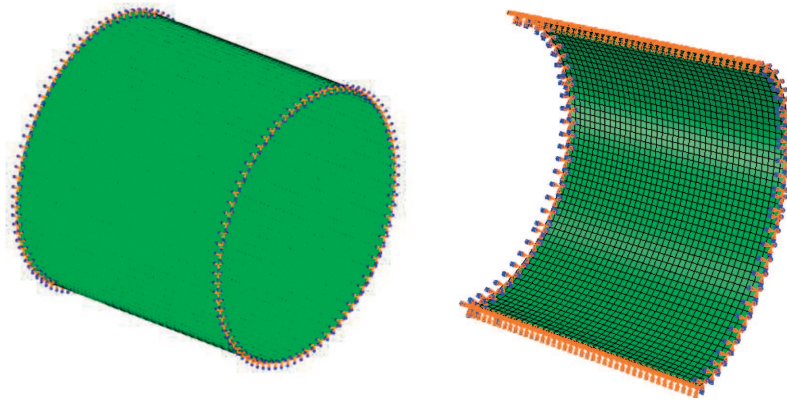

Fig. 19. Boundary conditions for shell membrane model, full model (left) and half model (right)

More realistic connection between the membrane (modelled with solid elements Figure 20 and 21) and the pump body were also analyzed. Nonlinear contact analysis of shrink – fit connection was performed in ABAQUS prior to the FSI step.

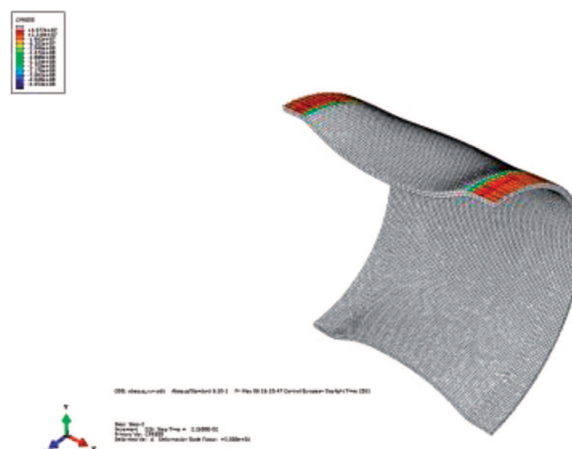

Fig. 20. Shrink- fit connection between membrane and pump body. Configuration w1 –half model

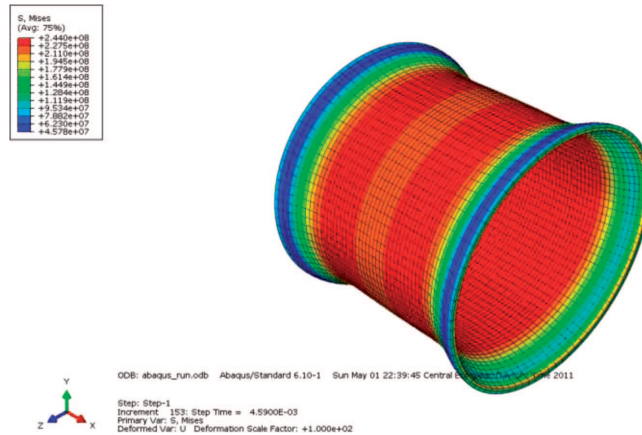

Fig. 21. Stresses in membrane (solid model). Configuration w5 –full model

CFD analysis required time step equal to 0.00003s and therefore a fixed time increment was used in FSI, ABAQUS (implicit dynamic) and FLUENT simultaneously.

Deflection of the membrane as well stresses in it varies with time accordingly to working pressure in the compensation chamber is presented in Figure 22.

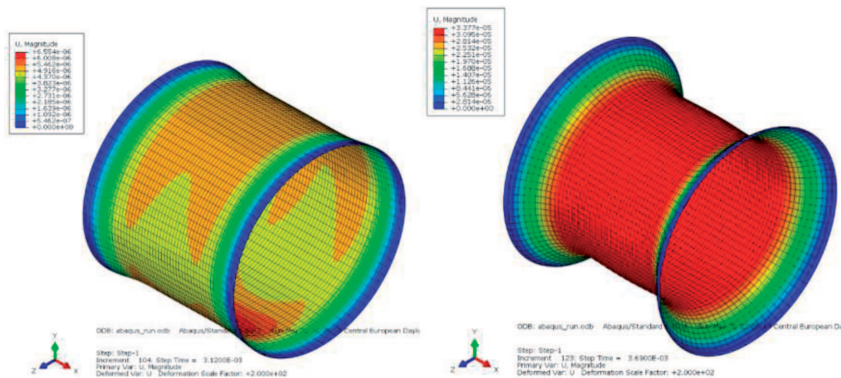

Fig. 22. Deflection of membrane at time 0.00312s (left), 0.00369 s (right). Configuration w5 – full pump

Maximum stresses from the FSI coupled analysis (Figure 21 – shell model) are comparable to stresses obtained from a simplified static analysis where 10 MPa pressure was applied as a working load (Figure 23).

Pressure plots from the FSI analysis for different measurement points in working and compensation chambers are depicted in Figure 22. As observed, there is no significant difference between CFD and FSI model (comparing Figure 24 to Figure 17).

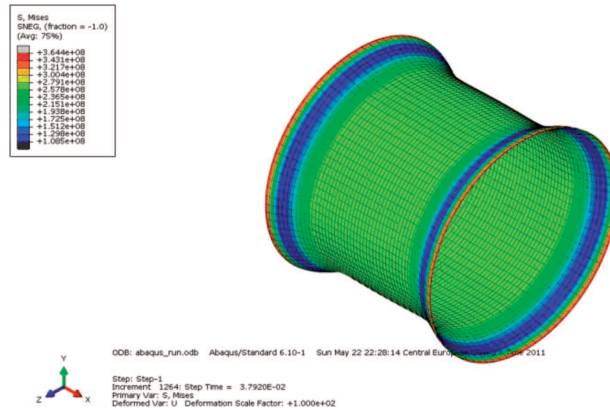

Fig. 23. Stresses in membrane (shell model) from coupled FSI analysis at time 0.03792 s. Configuration w5 – full pump

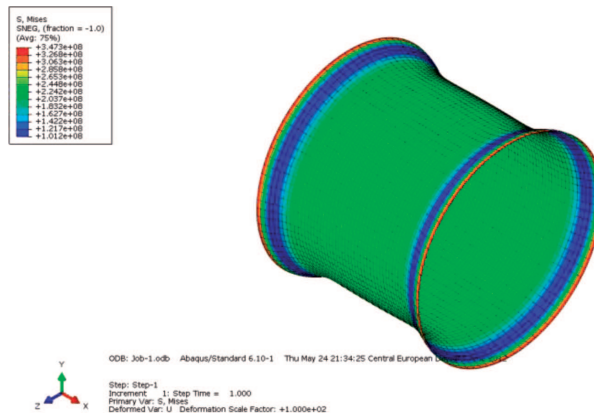

Fig. 24. Stresses in membrane (shell model) from simplified static analysis

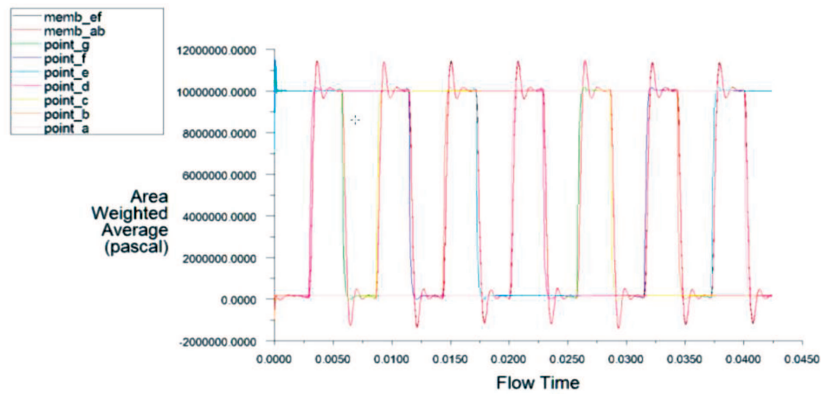

Fig. 25. Pressure plot in working chambers from FSI analysis. Configuration w5 – full pump

## 7. Conclusion from the FSI analysis

The inclusion of the Fluid Structure Interaction calculations in the membrane model analysis did not introduce any significant differences in the understanding of the membrane behaviour. The membrane flexibility was not sufficient to visibly change the volume of fluid in the compensation chamber, thus affecting the pressure plot of fluid. Nevertheless, the FSI approach was useful in order to predict the deflections and stresses in the membrane. It turns out that the fluid volume in the compensation chamber is capable to accept additional fluid from working chambers under pressure and it will mitigate pressure peaks, without visibly affecting deflection of the membrane.

Manuscript received by Editorial Board, September 03, 2012;  
final version, September 29, 2013.

## REFERENCES

- [1] Osiecki A.: Hydrostatyczny napęd maszyn; WNT; Warszawa 2004.
- [2] Ivantysyn J., Ivantysyn M.: Hydrostatische Pumpen und Motoren. Konstruktion und Berechnung. Vogel Buchverlag 1993.
- [3] Osiecki L., Patrosz P.: Analiza zjawisk dynamicznych w komorze cylindrowej pompy PWK o zmiennej wydajności. Rozdział w monografii „Badanie, konstrukcja wytwarzanie i eksploatacja układów hydraulicznych”, KOMAG, Gliwice 2010.
- [4] Osiecki L.: Maszyna hydrostatyczna wielotłoczkowa osiowa. Zgłoszenie patentowe nr P 393421.
- [5] Osiecki L., Śliwiński P.: Przekładnia planetarna. Patent PAT 214522.
- [6] Zawistowski T., Osiecki L., Patrosz P., Landvogt B., Piechna J., Zylinski B.: Numerical Simulation of Fluid-Structure Interaction in the Design Process of a Novel Axial Hydraulic Pump. Nafems European Conference: Multiphysics Simulation, 16-17 October 2012.
- [7] Landvogt B., Osiecki L., Zawistowski T., Zylinski B.: Numerical Simulation of Fluid-structure Interaction in the Design Process for a New Axial Hydraulic Pump. 3DS Simulia Community Conference, 15-17 May 2012, Providence.
- [8] Landvogt B., Osiecki L., Zawistowski T., Zylinski B.: Numerical Simulation of Fluid-Structure Interaction in the Design Process for a New Hydraulic Axial Pump. Automotive Simulation World Congress, 30-31 October, Detroit.
- [9] Landvogt B., Osiecki L., Zawistowski T., Zylinski B.: Interaction in Hydraulic Pump Design. Nasa Tech Briefs (October 2012); (<http://www.techbriefs.com/component/content/article/14887>)
- [10] Osiecki L., Piechna J., Zawistowski T., Zylinski B.: Multidisciplinary Approach to the Component Design of a New Axial Hydraulic Pump. The International Journal of MultiphysicsI, ISBN-978-1-907132-36-0, Special Edition: Multiphysics Simulations – Advanced Methods for Industrial Engineering.
- [11] Osiecki L., Patrosz P., Zawistowski T., Landvogt B., Piechna J., Zylinski B.: Compensation of pressure peaks in PWK-type hydraulic pumps. Key Engineering Materials Vol. 490 (2012) pp 33-44.

**Symulacja oddziaływań między cieczą a strukturą nowej konstrukcji wysokociśnieniowej hydraulicznej pompy tłokowej osiowej****Streszczenie**

Nowa odmiana wysokociśnieniowej pompy tłokowej osiowej o zmiennej wydajności stanowi znaczący postęp w projektowaniu systemów napędu hydraulicznego. Całkowite odciążenie od sił hydrostatycznych pozwala wyeliminować serwomechanizm sterujący, upraszczając konstrukcję pompy, zmniejszając jej ciężar i pozwalając na komputerowe sterowanie wydajnością. Pompy typu PWK, wynalezione na Politechnice Gdańskiej, osiągają wysoką sprawność przy ciśnieniu sięgającym 55 MPa i są samossawne nawet przy wysokiej prędkości obrotowej. Mechanizm rozrządu krzywkowego, będący podstawą wynalazku, generuje jednak szkodliwe piki ciśnienia. W celu ich zredukowania zaproponowano zastosowanie komory kompensującej z elastycznymi ścianami. Ze względu na dynamiczny charakter zjawisk zachodzących podczas pracy pompy w celu przeanalizowania genezy pików ciśnienia i doboru właściwych parametrów konstrukcyjnych komory kompensacyjnej konieczne było przeprowadzenie symulacji komputerowej. Dostępne pakiety CFD nie były jednak w stanie odwzorować złożonych zależności między ścianą komory kompensacyjnej a cieczą roboczą. Zaprezentowane w artykule podejście ukazuje oddziaływania między cieczą a strukturą pompy na przykładzie 3 różnych modeli: dwóch uproszczonych i pełnego modelu pompy.