

## DESIGN OF THREE CONTROL ALGORITHMS FOR AN AVERAGING TANK WITH VARIABLE FILLING

Michał KOLANKOWSKI<sup>✉</sup>, Robert PIOTROWSKI<sup>✉</sup>

\*Faculty of Electrical and Control Engineering, Gdańsk University of Technology,  
ul. G. Narutowicza 11/12, 80-233 Gdańsk, Poland

[michkola1999@gmail.com](mailto:michkola1999@gmail.com), [robert.piotrowski@pg.edu.pl](mailto:robert.piotrowski@pg.edu.pl)

received 3 January 2022, revised 28 February 2022, accepted 6 March 2022

**Abstract:** An averaging tank with variable filling is a nonlinear multidimensional system and can thus be considered a complex control system. General control objectives of such object include ensuring stability, zero steady-state error, and achieving simultaneously shortest possible settling time and minimal overshoot. The main purpose of this research work was the modeling and synthesis of three control systems for an averaging tank. In order to achieve the intended purpose, in the first step, a mathematical model of the control system was derived. The model was adapted to the form required to design two out of three planned control systems by linearization and reduction of its dimensions, resulting in two system variants. A multivariable proportional-integral-derivative (PID) control system for the averaging tank was developed using optimization for tuning PID controllers. State feedback and output feedback with an integral action control system for the considered control system was designed using a linear-quadratic regulator (LQR) and optimization of weights. A fuzzy control system was designed using the Mamdani inference system. The developed control systems were tested using the MATLAB environment. Finally, the simulation results for each control algorithm (and their variants) were compared and their performance was assessed, as well as the effects of optimization in the case of PID and integral control (IC) systems.

**Key words:** control system, fuzzy control system, integral control system, LQR, mathematical model, PID control system, state feedback controller, tank with variable filling

### 1. INTRODUCTION

An averaging tank with variable filling is a tank containing a substance with variable component concentration. The concentration is assumed to be even in the entire volume of the substance. The considered tank is with variable filling and thus the volume of substance contained in the tank is variable and the system's performance is not affected by it not being constant. Averaging in the tank may be achieved by mixing.

Averaging tanks are widely used, primarily in wastewater treatment for stabilizing the composition of wastewater. It is important because the technological parameters of the treatment process are determined based on the average composition of wastewater. Moreover, the averaging tank ensures a steady flow of wastewater to the further stages of the treatment process despite the input flow of wastewater to the tank being variable [1].

Because averaging tank is a nonlinear multiple-input–multiple-output (MIMO) system, it may be considered a complex control system. Traditional control methods may thus be insufficient, and modern, more advanced control algorithms should be applied.

Designing control algorithms for tank systems is a widely researched and relevant topic. In Astrom and Hagglund [2], proportional-integral-derivative (PID) controllers were applied for tank control. Multivariable PID was proposed for the control of a tank with heating [3]. The Control system for the quadruple tank was designed in Johansson [4] and Saeed et al. [5] using multi-loop, decentralized proportional-integral (PI) control. Moreover, in Saeed et al. [5], it was compared with generalized predictive

control (GPC), which is an optimal control method. In Meenatchi Sundaram and Venkateswaran [6], a Smith predictor for a system composed of three tanks was implemented. In Janani [7], the control of a two-tank system was achieved using a state feedback structure. In Bojan-Dragos et al. [8] and Berk et al. [9], fuzzy PID control systems for a vertical two-tank system and a single tank were designed.

The paper is a further development of the research works presented in Kolankowski and Piotrowski [10], which describes the modeling of the system in abridged form, the design of integral control (IC) system, and control results assessment. This paper also includes the design of multivariable PID control (using optimization for PID controllers tuning) and fuzzy control algorithms. Moreover, it compares the results of the developed control systems and summarizes their performance.

The structure of this paper is as follows. The derivation and implementation of the mathematical model of the averaging tank are described in Section 2. The design of control systems is presented in Section 3. In Section 4, the control results are discussed. The last section presents the conclusions.

### 2. DESCRIPTION AND MODELLING OF TANK

A substance of variable component concentration flows into the averaging tank (see Fig. 1). A substance of component concentration equal to the average concentration in the tank flows out of the tank. It is assumed that both inflow and outflow are forced.

Input (1–3) and output (4, 5) variables of the system are described in Tab. 1. The considered system is a MIMO system with 3 input variables and 2 output variables.

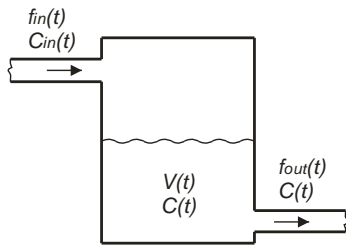

Fig. 1. Scheme of the averaging tank

Tab. 1. Symbols of variables and their units

No.	Description	Symbol	Unit
1.	Inflow rate of substance with component concentration $C_{in}(t)$	$f_{in}$	$m^3/s$
2.	Outflow rate of substance with component concentration $C(t)$	$f_{out}$	$m^3/s$
3.	Concentration of the component in the substance flowing into the tank	$C_{in}$	$kg/m^3$
4.	Volume of the substance of concentration $C(t)$ in tank	$V$	$m^3$
5.	Averaged component concentration in the tank	$C$	$kg/m^3$

### 2.1. Nonlinear model of tank

It is assumed that there are no disturbances and that mixing is instantaneous, and complete, lumped-parameter model can thus be applied. The model is based on the conservation of mass law (1) and the conservation of impurity law (2).

$$\frac{dV(t)}{dt} = f_{in}(t) - f_{out}(t) \quad (1)$$

$$\frac{d(V(t)C(t))}{dt} = f_{in}(t) \cdot C_{in}(t) - f_{out}(t) \cdot C(t) \quad (2)$$

The result of product  $V(t) \cdot C(t)$  in equation (2) is:

$$\frac{dV(t)}{t} \cdot C(t) + V(t) \cdot \frac{dC(t)}{dt} = f_{in}(t) \cdot C_{in}(t) - f_{out}(t) \cdot C(t) \quad (3)$$

Substituting  $V(t)$  from equation (1) in (3):

$$(f_{in}(t) - f_{out}(t)) \cdot C(t) + V(t) \cdot \frac{dC(t)}{t} = f_{in}(t) \cdot C_{in}(t) - f_{out}(t) \cdot C(t) \quad (4)$$

After transformation, equation (4) takes the form:

$$V(t) \cdot \frac{dC(t)}{dt} = f_{in}(t) \cdot C_{in}(t) - f_{in}(t) \cdot C(t) \quad (5)$$

The final model of the system takes the form (equations (5) and (1)):

$$\begin{cases} V(t) \cdot \frac{dC(t)}{dt} = f_{in}(t) \cdot (C_{in}(t) - C(t)) \\ \frac{dV(t)}{dt} = f_{in}(t) - f_{out}(t) \end{cases} \quad (6)$$

The derived model is described by a set of first-order differential equations (input/output model). For control purposes, this model is continuous, dynamic, nonlinear, deterministic, stationary, and a lumped-parameter model.

### 2.2. Linearization of tank model

Many control system structures and analysis methods are intended for linear systems exclusively. Thus, linearization of the control system model was necessary. It was performed by using a Taylor series expansion in the neighborhood of the equilibrium point  $(\dot{f}_{in0}, \dot{f}_{out0}, C_{in0}, C_0, V_0)$ . It can be performed, provided that the function is differentiable in a given point [11].

The nonlinear model was written as:

$$\dot{C}(t) = f_c(V(t), \dot{V}(t), C(t), \dot{C}(t), C_{in}(t), f_{in}(t), f_{out}(t)) \quad (7)$$

$$\dot{V}(t) = f_v(V(t), \dot{V}(t), C(t), \dot{C}(t), C_{in}(t), f_{in}(t), f_{out}(t)) \quad (8)$$

where

$$f_c(V(t), \dot{V}(t), C(t), \dot{C}(t), C_{in}(t), f_{in}(t), f_{out}(t)) = \frac{f_{in}(t)}{V(t)} \cdot C_{in}(t) - \frac{f_{out}(t)}{V(t)} \cdot C(t) \quad (9)$$

$$f_v(V(t), \dot{V}(t), C(t), \dot{C}(t), C_{in}(t), f_{in}(t), f_{out}(t)) = f_{in}(t) - f_{out}(t) \quad (10)$$

In the equilibrium point, the static equations of the system can be written as ( $\dot{V}(t) = 0$ ;  $\dot{C}(t) = 0$ ):

$$f_c(V_0, 0, C_0, 0, C_{in0}, f_{in0}, f_{out0}) = \frac{f_{in0}}{V_0} \cdot C_{in0} - \frac{f_{out0}}{V_0} \cdot C_0 = 0 \quad (11)$$

$$f_v(V_0, 0, C_0, 0, C_{in0}, f_{in0}, f_{out0}) = f_{in0} - f_{out0} = 0 \quad (12)$$

The static characteristics of the system were obtained:

$$\begin{cases} \frac{f_{in0}}{V_0} \cdot (C_{in0} - C_0) = 0 \\ f_{in0} - f_{out0} = 0 \end{cases} \quad (13)$$

Hence

$$\begin{cases} C_0 = C_{in0} \\ f_{in0} = f_{out0} \end{cases} \quad (14)$$

Introducing deviation variables

$$\begin{cases} \Delta C(t) = C(t) - C_0 \\ \Delta \dot{C}(t) = \dot{C}(t) - \dot{C}_0 = \dot{C}(t) \\ \Delta V(t) = V(t) - V_0 \\ \Delta \dot{V}(t) = \dot{V}(t) - \dot{V}_0 = \dot{V}(t) \\ \Delta C_{in}(t) = C_{in}(t) - C_{in0} \\ \Delta f_{in}(t) = f_{in}(t) - f_{in0} \\ \Delta f_{out}(t) = f_{out}(t) - f_{out0} \end{cases} \quad (15)$$

The final result linearized model takes the form

$$\begin{cases} V_0 \cdot \Delta \frac{dC(t)}{dt} = f_{in0} \cdot (\Delta C_{in}(t) - \Delta C(t)) + (C_{in0} - C_0) \cdot \Delta f_{in}(t) \\ \Delta \frac{dV(t)}{dt} = \Delta f_{in}(t) - \Delta f_{out}(t) \end{cases} \quad (16)$$

The coordinates of the equilibrium point  $(V_0, C_0, C_{in0},$  and  $f_{in0})$  appear in the equations of the linearized model as parameters.

The linearized model in input/output form was converted to transfer function form, assuming zero initial conditions. The linearized model in the s-domain is

$$\begin{cases} C(s) = \frac{1}{T \cdot s + 1} \cdot (k \cdot (C_{in0} - C_0) \cdot f_{in}(s) + C_{in}(s)) \\ V(s) = \frac{1}{s} \cdot (f_{in}(s) - f_{out}(s)) \end{cases} \quad (17)$$

where  $k = \frac{1}{f_{in0}}$ ;  $T = \frac{V_0}{f_{in0}}$ .

The control algorithms presented in subsections 3.1 and 3.2 use the linearized model of the system in state space in two ver-

sions: with the assumptions of constant outflow rate ( $f_{out}(t) = f_{out0}$ ) and constant inflow rate ( $f_{in}(t) = f_{in0}$ ). It is thus necessary to convert the model to state space form. In order to do so, state variables were chosen as follows:

$$\Delta x_1(t) = \Delta C(t) \tag{18}$$

$$\Delta x_2(t) = \Delta V(t) \tag{19}$$

They can be written as the state vector:

$$\Delta \mathbf{x}(t) = \begin{bmatrix} \Delta x_1(t) \\ \Delta x_2(t) \end{bmatrix} \tag{20}$$

Input variables are

$$\Delta u_1(t) = \Delta f_{in}(t) \tag{21}$$

$$\Delta u_2(t) = \Delta f_{out}(t) \tag{22}$$

$$\Delta u_3(t) = \Delta C_{in}(t) \tag{23}$$

They can be written as the input vector:

$$\Delta \mathbf{u}(t) = \begin{bmatrix} \Delta u_1(t) \\ \Delta u_2(t) \\ \Delta u_3(t) \end{bmatrix} \tag{24}$$

Output variables are

$$\Delta y_1(t) = \Delta C(t) \tag{25}$$

$$\Delta y_2(t) = \Delta V(t) \tag{26}$$

They can be written as the output vector:

$$\Delta \mathbf{y}(t) = \begin{bmatrix} \Delta y_1(t) \\ \Delta y_2(t) \end{bmatrix} \tag{27}$$

The values of variables in the equilibrium point can be converted to state space form as follows:

$$x_{1,0} = C_0; x_{2,0} = V_0; u_{1,0} = f_{in0}; u_{2,0} = f_{out0}; u_{3,0} = C_{in0} \tag{28}$$

Assuming  $f_{out}(t)=const$ , the input vector is changed and takes the form:

$$\Delta \mathbf{u}(t) = \begin{bmatrix} \Delta u_1(t) \\ \Delta u_3(t) \end{bmatrix} \tag{29}$$

Hence, the obtained linearized model is as follows:

$$\Delta \dot{\mathbf{x}}(t) = \mathbf{A} \cdot \Delta \mathbf{x}(t) + \mathbf{B} \cdot \Delta \mathbf{u}(t) \tag{30}$$

$$\Delta \mathbf{y}(t) = \mathbf{C} \cdot \Delta \mathbf{x}(t) + \mathbf{D} \cdot \Delta \mathbf{u}(t) \tag{31}$$

where

$$\mathbf{A} = \begin{bmatrix} -\frac{u_{1,0}}{x_{2,0}} & 0 \\ x_{2,0} & 0 \\ 0 & 0 \end{bmatrix}; \mathbf{B} = \begin{bmatrix} \frac{u_{3,0}-x_{1,0}}{x_{2,0}} & \frac{u_{1,0}}{x_{2,0}} \\ 1 & 0 \end{bmatrix}$$

$$\mathbf{C} = \begin{bmatrix} 1 & 0 \\ 0 & 1 \end{bmatrix}; \mathbf{D} = \begin{bmatrix} 0 & 0 \\ 0 & 0 \end{bmatrix} \tag{32}$$

$\mathbf{A}$  is state matrix;  $\mathbf{B}$  is input matrix;  $\mathbf{C}$  is output matrix;  $\mathbf{D}$  is feedthrough matrix.

Assuming  $f_{in}(t)=const$ , the input vector is changed and takes the form:

$$\Delta \mathbf{u}(t) = \begin{bmatrix} \Delta u_2(t) \\ \Delta u_3(t) \end{bmatrix} \tag{33}$$

The obtained linearized model is described by equations (30) and (31), where matrices  $\mathbf{A}$ ,  $\mathbf{B}$ ,  $\mathbf{C}$ , and  $\mathbf{D}$  take the form:

$$\mathbf{A} = \begin{bmatrix} -\frac{u_{1,0}}{x_{2,0}} & 0 \\ x_{2,0} & 0 \\ 0 & 0 \end{bmatrix}; \mathbf{B} = \begin{bmatrix} 0 & \frac{u_{1,0}}{x_{2,0}} \\ -1 & 0 \end{bmatrix}; \mathbf{C} = \begin{bmatrix} 1 & 0 \\ 0 & 1 \end{bmatrix}; \mathbf{D} = \begin{bmatrix} 0 & 0 \\ 0 & 0 \end{bmatrix} \tag{34}$$

A static equilibrium point was selected for the linearized model:  $(f_{in0}, f_{out0}, C_{in0}, C_0, V_0) = (0.2 \text{ m}^3/\text{s}; 0.2 \text{ m}^3/\text{s}; 5 \text{ kmol}/\text{m}^3; 5 \text{ kmol}/\text{m}^3; 2 \text{ m}^3)$  and the initial values of variables  $C(t)$  and  $V(t)$  were assumed as  $C_p = 5 \text{ kmol}/\text{m}^3; V_p = 2 \text{ m}^3$ .

### 3. DESIGN OF CONTROL SYSTEMS

#### 3.1. Multivariable PID control system

A control system with two PID controllers is a closed-loop system with output feedback from both process variables. The control error of each process variable is fed into an input of one of the PID controllers. The control law of a PID controller in Ideal Standard Algorithm (ISA) form is as follows [2]:

$$u(t) = K_p \cdot \left( e(t) + \frac{1}{T_i} \cdot \int_{t_0}^{t_0+t_f} e(t) dt + T_d \cdot \frac{de(t)}{dt} \right) \tag{35}$$

where  $u(t)$  is control variable,  $e(t)$  is control error,  $K_p$  is proportional gain,  $T_i$  is integral time,  $T_d$  is derivative time,  $t_0$  is initial time, and  $t_f$  is final time.

The block diagram of the control system is presented in Fig. 2.

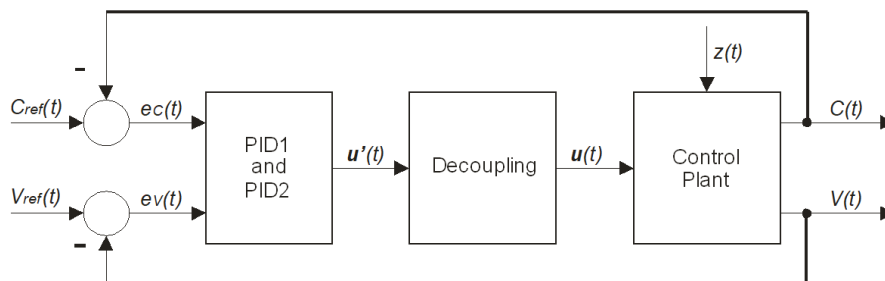

Fig. 2. Block diagram of multivariable PID control system. PID, proportional-integral-derivative

The output signals of the controllers are fed into the decoupling block. Then the signal is fed into the input of the control plant. The variable  $\mathbf{u}'(t)$  is a vector of signals generated by PID controllers. The variable  $z(t)$  represents disturbances affecting the

control plant. An example of a disturbance in a physical plant is the evaporation of a substance from the tank, which affects the volume of the substance in the tank.

The multivariable PID control system was designed based on the linearized model of the system (Eq. (16)) because PID control is a method dedicated to linear systems. A PID control structure for the MIMO system was designed according to the following methodology [17]:

I. Determination of transfer function of the system

The transfer function of the system was determined based on the state space form of the linearized model, using the equation

$$G_p(s) = C \cdot [s \cdot I^{(n)} - A]^{-1} \cdot B + D \quad (36)$$

II. Determination of relative gain matrix (RGA) of control plant and, according to it, determination of the desired coupling of inputs and outputs

$$\Lambda(G) = K \circ (K^{-1})^T \quad (37)$$

where  $\Lambda(G)$  is relative gain matrix,  $K$  is static gain matrix, and  $\circ$  is Hadamard product.

There are two possible pairings for a Two-Input Two-Output (TITO) system: 1-1/2-2 and 1-2/2-1. Generally, a system of  $n \times n$  dimensions has  $n!$  possible pairings.

The transfer function matrix of controllers for decentralized control takes the form:

$$G_c(s) = \begin{bmatrix} G_{c1}(s) & 0 \\ 0 & G_{c2}(s) \end{bmatrix} \text{ for 1-1/2-2 coupling} \quad (38)$$

or

$$G_c(s) = \begin{bmatrix} 0 & G_{c2}(s) \\ G_{c1}(s) & 0 \end{bmatrix} \text{ for 1-2/2-1 coupling} \quad (39)$$

III. Determination of decoupler structure, if necessary, i.e., if transfer function matrix is not diagonal

The transfer function of the decoupler in all control loops can be written as

$$T(s) = \begin{bmatrix} T_{12}(s) & T_{22}(s) \\ T_{11}(s) & T_{21}(s) \end{bmatrix} \quad (40)$$

The transfer function of the open-loop system can be written as

$$G_{OL}(s) = G_p(s) \cdot T(s) \cdot G_c(s) \quad (41)$$

IV. Determination of the type of PID controller and controller's parameters which ensure the stability of the closed-loop system and the required performance of the system

The transfer function of a closed-loop control system with negative feedback is as follows

$$G_{CL}(s) = G_p(s) \cdot T(s) \cdot G_c(s) \cdot [I + G_p(s) \cdot T(s) \cdot G_c(s)]^{-1} \quad (42)$$

The error transfer function of a closed-loop system (the quotient of Laplace transform of control error and input) is as follows

$$G_E(s) = [I + G_p(s) \cdot T(s) \cdot G_c(s)]^{-1} \quad (43)$$

The displacement error in steady state is

$$e_{ss} = \lim_{s \rightarrow 0} s \cdot G_E(s) \cdot \frac{A}{s} \quad (44)$$

1.1.1. Selection of controller type and parameters for  $f_{out}(t)=const$  system

Ad. I. The transfer function of the control plant takes the form

$$G_p(s) = \begin{bmatrix} \frac{u_{3,0} - x_{1,0}}{u_{1,0} + s \cdot x_{2,0}} & \frac{u_{1,0}}{u_{1,0} + s \cdot x_{2,0}} \\ \frac{1}{s} & 0 \end{bmatrix} \quad (45)$$

In the assumed operating point, it is

$$G_p(s)|_{s_0} = \begin{bmatrix} 0 & \frac{1}{10s+1} \\ \frac{1}{s} & 0 \end{bmatrix} \quad (46)$$

Ad. II. The RGA for the considered control plant is

$$\Lambda(G) = \begin{bmatrix} 0 & 1 \\ 1 & 0 \end{bmatrix} \quad (47)$$

It means that only the couple of transfer functions  $G_{21}(s)$  and  $G_{12}(s)$  affect the value of the process variable in steady state. Hence, the appropriate pairing is 1-2/2-1 in this case. The transfer function matrix of the controller takes the form:

$$G_c(s) = \begin{bmatrix} 0 & G_{c2}(s) \\ G_{c1}(s) & 0 \end{bmatrix} \quad (48)$$

Ad. III. The transfer function matrix of the control plant is not diagonal, but triangular. Hence, a structure which removes the influence of the input  $U_1$  on the output  $Y_1$  was implemented. In order to do that, the transfer function of the decoupler  $T_{11}(s)$ , whose task is to compensate this influence, was determined

$$T_{11}(s) \cdot G_{p12}(s) \cdot U_{21}(s) + G_{p11}(s) \cdot U_{21}(s) = 0 \quad (49)$$

From equation (49),  $T_{11}(s) = -\frac{G_{p11}(s)}{G_{p12}(s)}$  was determined.

A block diagram of the control system with decoupling is shown in Fig. 3.

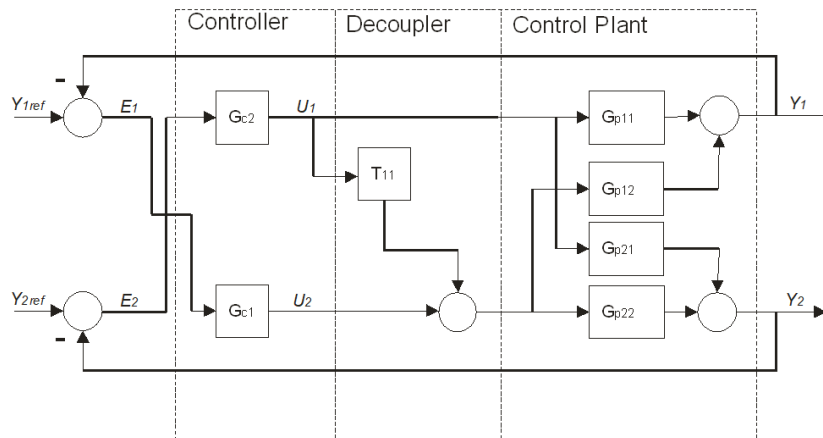

Fig. 3. Block diagram of the control system with decoupling

The decoupling matrix takes the form

$$\mathbf{T}(s) = \begin{bmatrix} 1 & 0 \\ -\frac{G_{p11}(s)}{G_{p12}(s)} & 1 \end{bmatrix} = \begin{bmatrix} 1 & 0 \\ -\frac{u_{3,0}-x_{1,0}}{u_{1,0}} & 1 \end{bmatrix} |_{s_0} = \begin{bmatrix} 1 & 0 \\ 0 & 1 \end{bmatrix} \quad (50)$$

Thus, for the selected equilibrium point, the introduction of additional decoupling does not affect the performance of the control system.

Ad. IV. Determination of the type of PID controller and controller's parameters

For type P (proportional) controllers, the matrix  $\mathbf{G}_c(s)$  takes the form

$$\mathbf{G}_c(s) = \begin{bmatrix} 0 & K_{p2} \\ K_{p1} & 0 \end{bmatrix} \quad (51)$$

The closed-loop transfer function takes the form

$$\mathbf{G}_{CL}(s) = \begin{bmatrix} \frac{K_{p1} \cdot u_{1,0}}{s \cdot x_{2,0} + u_{1,0} \cdot (1 + K_{p1})} & 0 \\ 0 & \frac{K_{p2}}{s + K_{p2}} \end{bmatrix} \quad (52)$$

The closed-loop system is stable if  $K_{p1} > 0$  and  $K_{p2} > 0$ , because poles in both of its transfer functions are located in the left half-plane of the s-plane. The error transfer function of the closed-loop system is

$$\mathbf{G}_E(s) = \begin{bmatrix} \frac{s \cdot x_{2,0} + u_{1,0}}{s \cdot x_{2,0} + u_{1,0} \cdot (1 + K_{p1})} & 0 \\ 0 & \frac{s}{s + K_{p2}} \end{bmatrix} \quad (53)$$

The steady-state displacement error is

$$\mathbf{e}_{ss} = \begin{bmatrix} \frac{A}{1 + K_{p1}} & 0 \\ 0 & 0 \end{bmatrix} \quad (54)$$

The control system with type P controllers thus does not ensure zero steady-state error of the process variable  $y(t)$ , which is  $C(t)$ .

For type proportional-integral (PI) controllers the matrix  $\mathbf{G}_R(s)$  takes the form:

$$\mathbf{G}_c(s) = \begin{bmatrix} 0 & K_{p2} \cdot \left(1 + \frac{1}{T_{i2} \cdot s}\right) \\ K_{p1} \cdot \left(1 + \frac{1}{T_{i1} \cdot s}\right) & 0 \end{bmatrix} \quad (55)$$

The closed-loop transfer function takes the form

$$\mathbf{G}_{CL}(s) = \begin{bmatrix} \frac{K_{p1} \cdot u_{1,0} (1 + T_{i1} \cdot s)}{s^2 \cdot T_{i1} \cdot x_{2,0} + s \cdot T_{i1} \cdot u_{1,0} \cdot (1 + K_{p1}) + u_{1,0} \cdot K_{p1}} & 0 \\ 0 & \frac{K_{p2} \cdot (1 + T_{i2} \cdot s)}{s^2 \cdot T_{i2} + s \cdot T_{i2} \cdot K_{p2} + K_{p2}} \end{bmatrix} \quad (56)$$

The closed-loop system is stable if  $K_{p1} > 0$ ,  $K_{p2} > 0$ ,  $T_{i1} > 0$ , and  $T_{i2} > 0$ , because poles in both of its transfer functions are located in the left half-plane of the s-plane. The error transfer function of the closed-loop system is

$$\mathbf{G}_E(s) = \begin{bmatrix} \frac{T_{i1} \cdot x_{2,0} \cdot s^2 + T_{i1} \cdot u_{1,0} \cdot s}{s^2 \cdot T_{i1} \cdot x_{2,0} + s \cdot T_{i1} \cdot u_{1,0} \cdot (1 + K_{p1}) + u_{1,0} \cdot K_{p1}} & 0 \\ 0 & \frac{T_{i2} \cdot s^2}{s^2 \cdot T_{i2} + s \cdot T_{i2} \cdot K_{p2} + K_{p2}} \end{bmatrix} \quad (57)$$

The steady-state displacement error is

$$\mathbf{e}_{ss} = \begin{bmatrix} 0 & 0 \\ 0 & 0 \end{bmatrix} \quad (58)$$

The control system with PI-type controllers thus ensures zero-steady state error for both process variables.

For type proportional-integral-derivative (PID) controllers, the matrix  $\mathbf{G}_c(s)$  takes the form

$$\mathbf{G}_c(s) = \begin{bmatrix} 0 & K_{p2} \cdot \left(1 + \frac{1}{T_{i2} \cdot s} + T_{d2} \cdot s\right) \\ K_{p1} \cdot \left(1 + \frac{1}{T_{i1} \cdot s} + T_{d1} \cdot s\right) & 0 \end{bmatrix} \quad (59)$$

The closed-loop transfer function takes the form

$$\mathbf{G}_{CL}(s) = \begin{bmatrix} \frac{K_{p1} \cdot u_{1,0} (1 + T_{i1} \cdot s + T_{d1} \cdot T_{i1} \cdot s^2)}{s^2 \cdot T_{i1} (x_{2,0} + T_{d1} \cdot K_{p1} \cdot u_{1,0}) + s \cdot T_{i1} \cdot u_{1,0} (1 + K_{p1}) + u_{1,0} \cdot K_{p1}} & 0 \\ \frac{K_{p2} \cdot (1 + T_{i2} \cdot s + T_{d2} \cdot T_{i2} \cdot s^2)}{s^2 \cdot T_{i2} (1 + T_{d1} \cdot K_{p1}) + s \cdot T_{i2} \cdot K_{p2} + K_{p2}} \end{bmatrix} \quad (60)$$

The closed-loop system is stable if  $K_{p1} > 0$ ,  $K_{p2} > 0$ ,  $T_{i1} > 0$ ,  $T_{i2} > 0$ ,  $T_{d1} > 0$ , and  $T_{d2} > 0$ , because poles in both of its transfer functions are located in the left half-plane of the s-plane. The addition of a derivative term does not affect the steady-state error; thus, it is zero for PI controllers.

The general form of the control law for this system is

$$\Delta \mathbf{u}(t) = \begin{bmatrix} \Delta f_{in}(t) \\ \Delta C_{in}(t) \end{bmatrix} = \begin{bmatrix} K_{p2} \cdot \left( \Delta e_V(t) + \frac{1}{T_{i2}} \cdot \int_{t_0}^{t_0+t_f} \Delta e_V(t) dt + T_{d2} \cdot \frac{d\Delta e_V(t)}{dt} \right) \\ K_{p1} \cdot \left( \Delta e_C(t) + \frac{1}{T_{i1}} \cdot \int_{t_0}^{t_0+t_f} \Delta e_C(t) dt + T_{d1} \cdot \frac{d\Delta e_C(t)}{dt} \right) \end{bmatrix} \quad (61)$$

where

$$\Delta e_C(t) = \Delta C_{ref}(t) - \Delta C(t); \Delta e_V(t) = \Delta V_{ref}(t) - \Delta V(t). \quad (62)$$

### 1.1.2. Selection of controller type and parameters $\mathbf{f}$ or $\mathbf{f}_{in}(t)=\text{const}$ system

Ad. I. The transfer function of the control plant is described by equation (63)

$$\mathbf{G}_p(s) = \begin{bmatrix} 0 & \frac{u_{1,0}}{u_{1,0} + s \cdot x_{2,0}} \\ -\frac{1}{s} & 0 \end{bmatrix} \quad (63)$$

In the assumed equilibrium point, it is

$$\mathbf{G}_p(s)|_{s_0} = \begin{bmatrix} 0 & \frac{1}{10 \cdot s + 1} \\ -\frac{1}{s} & 0 \end{bmatrix} \quad (64)$$

Ad. II. The RGA for the considered control plant is as follows

$$\Lambda(\mathbf{G}) = \begin{bmatrix} 0 & 1 \\ 1 & 0 \end{bmatrix} \quad (65)$$

It means that only the couple of transfer functions  $G_{21}(s)$  and  $G_{12}(s)$  affect the value of the process variable in steady state. Hence, the appropriate pairing is 1-2/2-1 in this case. The transfer function matrix of the controller takes the form:

$$\mathbf{G}_c(s) = \begin{bmatrix} 0 & G_{c2}(s) \\ G_{c1}(s) & 0 \end{bmatrix} \quad (66)$$

Ad. III. The transfer function matrix of the control plant is diagonal. Hence, decoupling may be skipped in this case. The decoupler matrix  $T(s)$  is an identity matrix

Ad. IV. Determination of the type of PID controller and controller's parameters.

For type P controllers, the matrix  $G_c(s)$  takes the form

$$G_c(s) = \begin{bmatrix} 0 & K_{p2} \\ K_{p1} & 0 \end{bmatrix} \quad (67)$$

The closed-loop transfer function takes the form

$$G_{CL}(s) = \begin{bmatrix} \frac{K_{p1}u_{1,0}}{s \cdot x_{2,0} + u_{1,0}(1+K_{p1})} & 0 \\ 0 & \frac{K_{p2}}{-s+K_{p2}} \end{bmatrix} \quad (68)$$

In order to ensure the stability of the closed-loop system, it is necessary to place the pole of the transfer function  $G_{CL22}(s)$ , which is the transfer function of the control loop for  $V(t)$ , in the left half-plane of the s-plane. Hence, the condition for system's stability is  $K_{p2} < 0$ . It can be fulfilled by placing a gain of -1 in the control loop of  $V(t)$ . Then the matrix  $G_c(s)$  takes the form

$$G_c(s) = \begin{bmatrix} 0 & -K_{p2} \\ K_{p1} & 0 \end{bmatrix} \quad (69)$$

The closed-loop system is stable if  $K_{p1} > 0$  and  $-K_{p2} > 0$ . The error transfer function of the closed-loop system is

$$G_E(s) = \begin{bmatrix} \frac{s \cdot x_{2,0} + u_{1,0}}{s \cdot x_{2,0} + u_{1,0}(1+K_{p1})} & 0 \\ 0 & \frac{s}{s+K_{p2}} \end{bmatrix} \quad (70)$$

The steady-state displacement error is

$$e_{ss} = \begin{bmatrix} \frac{A}{1+K_{p1}} & 0 \\ 0 & 0 \end{bmatrix} \quad (71)$$

The control system with P-type controllers thus does not ensure zero steady-state error of the process variable  $y_1(t)$ , which is  $C(t)$ .

For type PI controllers, the matrix  $G_c(s)$  takes the form

$$G_R(s) = \begin{bmatrix} 0 & -K_{p2} \cdot (1 + \frac{1}{T_{i2} \cdot s}) \\ K_{p1} \cdot (1 + \frac{1}{T_{i1} \cdot s}) & 0 \end{bmatrix} \quad (72)$$

The closed-loop transfer function takes the form

$$G_{CL}(s) = \begin{bmatrix} \frac{K_{p1} \cdot u_{1,0}(1+T_{i1} \cdot s)}{s^2 \cdot T_{i1} \cdot x_{2,0} + s \cdot T_{i1} \cdot u_{1,0}(1+K_{p1}) + u_{1,0} \cdot K_{p1}} & 0 \\ 0 & \frac{K_{p2} \cdot (1+T_{i2} \cdot s)}{s^2 \cdot T_{i2} + s \cdot T_{i2} \cdot K_{p2} + K_{p2}} \end{bmatrix} \quad (73)$$

The closed-loop system is stable if  $K_{p1} > 0$ ,  $-K_{p2} > 0$ ,  $T_{i1} > 0$ , and  $T_{i2} > 0$ . The error transfer function of the closed-loop system is

$$G_E(s) = \begin{bmatrix} \frac{T_{i1} \cdot x_{2,0} \cdot s^2 + T_{i1} \cdot u_{1,0} \cdot s}{s^2 \cdot T_{i1} \cdot x_{2,0} + s \cdot T_{i1} \cdot u_{1,0}(1+K_{p1}) + u_{1,0} \cdot K_{p1}} & 0 \\ 0 & \frac{T_{i2} \cdot s^2}{s^2 \cdot T_{i2} + s \cdot T_{i2} \cdot K_{p2} + K_{p2}} \end{bmatrix} \quad (74)$$

The steady-state displacement error is

$$e_{ss} = \begin{bmatrix} 0 & 0 \\ 0 & 0 \end{bmatrix} \quad (75)$$

The control system with PI-type controllers thus ensures zero steady-state error for both process variables.

For type PID controllers, the matrix  $G_c(s)$  takes the form

$$G_c(s) = \begin{bmatrix} 0 & -K_{p2} \cdot (1 + \frac{1}{T_{i2} \cdot s} + T_{d2} \cdot s) \\ K_{p1} \cdot (1 + \frac{1}{T_{i1} \cdot s} + T_{d1} \cdot s) & 0 \end{bmatrix} \quad (76)$$

The closed-loop transfer function takes the form

$$G_{CL}(s) = \begin{bmatrix} \frac{K_{p1} \cdot u_{1,0}(1 + T_{i1} \cdot s + T_{d1} \cdot T_{i1} \cdot s^2)}{s^2 \cdot T_{i1} \cdot (x_{2,0} + T_{d1} \cdot K_{p1} \cdot u_{1,0}) + s \cdot T_{i1} \cdot u_{1,0} \cdot (1 + K_{p1}) + u_{1,0} \cdot K_{p1}} & 0 \\ \frac{K_{p2} \cdot (1+T_{i2} \cdot s + T_{d2} \cdot T_{i2} \cdot s^2)}{s^2 \cdot T_{i2} \cdot (1+T_{d1} \cdot K_{p1}) + s \cdot T_{i2} \cdot K_{p2} + K_{p2}} \end{bmatrix} \quad (77)$$

The closed-loop system is stable if  $K_{p1} > 0$ ,  $-K_{p2} > 0$ ,  $T_{i1} > 0$ ,  $T_{i2} > 0$ ,  $T_{d1} > 0$ , and  $T_{d2} > 0$ . The addition of a derivative term does not affect the steady-state error; thus, it is zero as in the case of PI controllers.

The general form of the control law for this system is

$$\Delta u(t) = \begin{bmatrix} \Delta f_{out}(t) \\ \Delta C_{in}(t) \end{bmatrix} = \begin{bmatrix} -K_{p2} \left( \Delta e_V(t) + \frac{1}{T_{i2}} \int_{t_0}^{t_0+t_k} \Delta e_V(t) dt + T_{d2} \frac{d\Delta e_V(t)}{dt} \right) \\ K_{p1} \left( \Delta e_C(t) + \frac{1}{T_{i1}} \int_{t_0}^{t_0+t_k} \Delta e_C(t) dt + T_{d1} \frac{d\Delta e_C(t)}{dt} \right) \end{bmatrix} \quad (78)$$

### 1.1.3. Optimization of controller parameters

In order to acquire the optimal parameters of PID controllers, optimization was performed based on integral performance indices of control variables  $C(t)$  and  $V(t)$ :

$$IE = \int_0^\infty e(t) dt \quad (79a)$$

$$ISE = \int_0^\infty e^2(t) dt \quad (79b)$$

$$IAE = \int_0^\infty |e(t)| dt \quad (79c)$$

$$ITAE = \int_0^\infty t|e(t)| dt \quad (79d)$$

$$ISEG = \int_0^\infty (e^2(t) + a\dot{e}^2(t)) dt; a=0.5 \quad (79e)$$

where  $e(t)$  is control error.

Optimization was performed using the method of minimizing the maximum of a set of objective functions [13]. In this case, the objective functions are the integral performance indices of process variables  $C(t)$  and  $V(t)$ . The decision variables are the parameters of both controllers. It was assumed that all decision variables must be nonnegative (as constraints). The optimization was performed for the nonlinear model of the tank, and absolute variables were converted to deviation variables, on which PID controllers operate. The performance index Integral of Squared Error Generalized (ISEG) was not used in the case of multivariable PID control because the results for it were invalid.

Given that the classical tuning methods, such as I and II Ziegler-Nichols method, are dedicated to single-input single-output (SISO) systems, rough values of PID constants, which serve as initial values of decision variables in the optimization process, were experimentally determined so that the system is stable and its performance is fine.



The optimization was performed for three types of the controller: P, PI, and PID and for the system with  $f_{out}(t) = \text{const}$  and the system with  $f_{in}(t) = \text{const}$ . Optimization results were assessed based on the values of the integral indices and the graphs of process and control variables. Best results were achieved for PI-type controllers for both versions of the control system. For the system with  $f_{out}(t) = \text{const}$ , the initial constants (determined experimentally) were as given in (80) and the optimal values of the constants (optimal with respect to IE) were as given in (81).

$$\begin{cases} K_{pC} = 50 \\ T_{iC} = 1 \\ K_{pV} = 8 \\ T_{iV} = 2 \end{cases} \quad (80)$$

$$\begin{cases} K_{pC} = 74.37 \\ T_{iC} = 8.325 \cdot 10^{-4} \\ K_{pV} = 8.000 \\ T_{iV} = 0.500 \end{cases} \quad (81)$$

For the system with  $f_{in}(t) = \text{const}$ , the initial constants (determined experimentally) were as given in (82) and the optimal values of the constants (optimal with respect to IE) were as shown in (83).

$$\begin{cases} K_{pC} = 50 \\ T_{iC} = 10 \\ K_{pV} = 5 \\ T_{iV} = 30 \end{cases} \quad (82)$$

$$\begin{cases} K_{pC} = 61.5 \\ T_{iC} = 7.641 \cdot 10^{-4} \\ K_{pV} = 5.034 \\ T_{iV} = 3.208 \cdot 10^{-2} \end{cases} \quad (83)$$

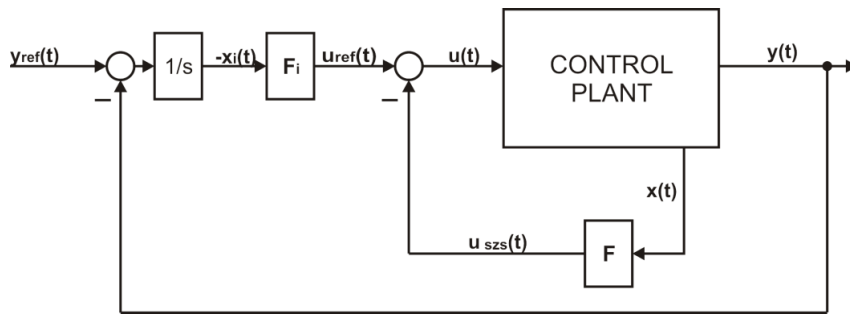

Fig. 4. Block diagram of IC system. IC, integral control

where  $y_{ref}(t)$ ,  $x_i(t)$ ,  $u_{ref}(t)$ ,  $u_{szs}(t)$ ,  $F_i$ , and  $F$  are reference value vector, integral state variable vector, the component of control variable vector influenced by output feedback, the component of control variable vector influenced by state feedback, gain in output feedback loop matrix, and gain in state feedback loop matrix, respectively.

In order to formulate a description of an expanded system, it is necessary to introduce a deviation integral state variable  $\Delta x_i(t)$ . It consists of integrated errors, which allow for output variable following its reference value. Then the equations of the expanded system take the form (84)–(85). The state vector of the expanded system is as given in (86) or in expanded form as shown in (87).

$$\Delta \dot{x}(t) = A \cdot \Delta x(t) + B \cdot \Delta u(t) \quad (84)$$

### 3.2. State feedback control system

In order to design a control system structure with output feedback and state feedback, the linearized model of the tank was converted to state-space form (see Section 2), because the control algorithm is dedicated to linear systems. It was necessary in order to build an expanded model and determine gain matrices in output feedback loop  $F_i$  and in state feedback loop  $F$ . The values of these matrices may be determined using multiple methods, for instance, pole placement method or optimal regulator method. In this case, the linear-quadratic regulator (LQR) method was used [14]. Due to the fact that the number of control inputs must not exceed the number of state variables of the control, reduction of the number of control inputs of the system was necessary. It was accomplished in two ways: by assumption of  $f_{out}(t) = f_{out0}$  and by assumption of  $f_{in}(t) = f_{in0}$ . The reduced state-space model is described by the equations (30), (31), and additionally (29) and (32) in the  $f_{out}(t) = \text{const}$  system and (33) and (34) in the  $f_{out}(t) = \text{const}$  system. The assumption of  $C_{in}(t) = C_{in0}$  is inexpedient for this model because it would prevent the change of  $C(t)$  since there is only one substance inflowing into the tank.

A control system structure with output feedback and full-state feedback can ensure zero steady-state error only given that the exact model of the system and the dynamics of control inputs are known. In order to ensure greater insensitivity to the uncertainty of the model of the system and the dynamics of its input variables and thus improve the system's robustness, integral action must be applied. It should be implemented in the output feedback loop, in series with the control plant. The introduction of integral action causes an increase in the rank of astatism of the control system.

IC structure is a control structure with state feedback and output feedback with integral action (see Fig. 4).

$$\Delta \dot{x}_i(t) = C \cdot \Delta x(t) + M \cdot \Delta u(t) - y_{ref}(t) \quad (85)$$

$$\Delta x_{exp}(t) = \begin{bmatrix} \Delta x(t) \\ \Delta x_i(t) \end{bmatrix} = \begin{bmatrix} \Delta x_1(t) \\ \Delta x_2(t) \\ \Delta x_{i1}(t) \\ \Delta x_{i2}(t) \end{bmatrix} \quad (86)$$

$$\Delta \dot{x}_{exp}(t) = A_{exp} \cdot \Delta x_{exp}(t) + B_{exp} \cdot \Delta u(t) - \begin{bmatrix} 0 \\ 1 \end{bmatrix} \cdot y_{ref}(t) \quad (87)$$

where  $M$  is direct input on the output impact matrix.

The state matrix  $A_{exp}$ , the input matrix  $B_{exp}$ , and  $M$  of the expanded system are

$$A_{exp} = \begin{bmatrix} A & 0 \\ C & 0 \end{bmatrix}; \quad B_{exp} = \begin{bmatrix} B \\ M \end{bmatrix}; \quad \text{and } M = \begin{bmatrix} 0 & 0 & 0 \\ 0 & 0 & 0 \end{bmatrix} \quad (88)$$

It is possible to design an IC system only if the expanded system is controllable. An expanded system can be considered controllable only if the following two conditions are met:

1. The primary system is controllable,
2. The number of control variables is no less than that of the number of process variables.

Control law takes the form

$$\Delta \mathbf{u}(t) = -\mathbf{F}_{exp} \cdot \Delta \mathbf{x}_{exp}(t) = -[\mathbf{F} \quad \mathbf{F}_i] \cdot \begin{bmatrix} \Delta \mathbf{x}(t) \\ \Delta \mathbf{x}_i(t) \end{bmatrix} \quad (89)$$

where  $\mathbf{F}_{exp}$  is the gain matrix of the expanded system.

In the case of the considered system, the gain matrix takes the form

$$\mathbf{F}_{exp} = [\mathbf{F} \quad \mathbf{F}_i] = \begin{bmatrix} F_{11} & F_{12} & F_{i11} & F_{i12} \\ F_{21} & F_{22} & F_{i21} & F_{i22} \end{bmatrix} \quad (90)$$

The LQR method, which was selected to find the value of the  $\mathbf{F}_{exp}$  matrix, is an optimal linear state feedback controller with a quadratic performance criterion. In general, for a linear, stationary system described by equation (30) and for the infinite time horizon, the cost function is as follows:

$$J(\mathbf{u}) = \frac{1}{2} \cdot \int_0^\infty [\mathbf{x}^T(t) \cdot \mathbf{Q} \cdot \mathbf{x}(t) + \mathbf{u}^T(t) \cdot \mathbf{R} \cdot \mathbf{u}(t)] dt \quad (91)$$

where  $\mathbf{Q}$  is a positive semidefinite, symmetric weight of state deviation  $n \times n$  matrix ( $n$  is the dimension of the  $\mathbf{x}(t)$  vector); and  $\mathbf{R}$  is a positive definite, symmetric weight of input usage  $r \times r$  matrix ( $r$  is the dimension of the  $\mathbf{u}(t)$  vector). The first term of (91) is associated with control error. The second term is associated with the value of control variables. Infinite time was used in order to ensure that the controller stays near the equilibrium point after the initial transition state. An infinite-time LQR can be used under the condition that the system is completely controllable. Finding proper values of weight matrices  $\mathbf{Q}$  and  $\mathbf{R}$  allows to achieve a compromise between the control error and the control cost [14, 15].

It was necessary to design a control system in two configurations: with  $f_{out}(t)=const$  and with  $f_{in}(t)=const$ . In the case of the first configuration, the state matrix and the input matrix of the expanded system were achieved as follows:

$$\mathbf{A}_{roz} = \begin{bmatrix} -\frac{u_{1,0}}{x_{2,0}} & 0 & 0 & 0 \\ 0 & 0 & 0 & 0 \\ 1 & 0 & 0 & 0 \\ 0 & 1 & 0 & 0 \end{bmatrix} = \begin{bmatrix} -0.1 & 0 & 0 & 0 \\ 0 & 0 & 0 & 0 \\ 1 & 0 & 0 & 0 \\ 0 & 1 & 0 & 0 \end{bmatrix} \quad (92)$$

$$\mathbf{B}_{roz} = \begin{bmatrix} \frac{u_{3,0}-x_{1,0}}{x_{2,0}} & \frac{u_{1,0}}{x_{2,0}} \\ 1 & 0 \\ 0 & 0 \\ 0 & 0 \end{bmatrix} = \begin{bmatrix} 0 & 0.1 \\ 1 & 0 \\ 0 & 0 \\ 0 & 0 \end{bmatrix} \quad (93)$$

Hence, the controllability of the expanded system was determined.

Condition I

In order to determine the controllability of the primary system, a Kalman controllability matrix for this system was created.

$$\mathbf{M}_{CK} = [\mathbf{B} \quad \mathbf{AB}] = \begin{bmatrix} \frac{u_{3,0}-x_{1,0}}{x_{2,0}} & \frac{u_{1,0}}{x_{2,0}} & \frac{-u_{1,0} \cdot (u_{3,0}-x_{1,0})}{x_{2,0}^2} & \frac{u_{1,0}^2}{x_{2,0}^2} \\ 1 & 0 & 0 & 0 \end{bmatrix} \quad (94)$$

For the previously chosen operating point,  $\text{rank}(\mathbf{M}_{CK}) = \text{rank}(\mathbf{A}) = 2$  and thus the primary system is controllable.

Condition II

For the considered system,  $\text{rank}(\mathbf{u}) = 2$  and  $\text{rank}(\mathbf{y}) = 2$ , thus the condition is met. Since both conditions are met, the

expanded system is controllable. For  $f_{in}(t)=const$ , the system configuration state matrix of the expanded system is the same as for the  $f_{out}(t)=const$  configuration (see equation (92)), while the input matrix takes the form

$$\mathbf{B}_{exp} = \begin{bmatrix} 0 & \frac{u_{1,0}}{x_{2,0}} \\ -1 & 0 \\ 0 & 0 \\ 0 & 0 \end{bmatrix} = \begin{bmatrix} 0 & 0.1 \\ -1 & 0 \\ 0 & 0 \\ 0 & 0 \end{bmatrix} \quad (95)$$

Hence, the controllability of the expanded system was determined.

Condition I

In order to determine the controllability of the primary system, a Kalman controllability matrix for this system was created:

$$\mathbf{M}_{CK} = [\mathbf{B} \quad \mathbf{AB}] = \begin{bmatrix} 0 & \frac{u_{1,0}}{x_{2,0}} & 0 & \frac{-u_{1,0}^2}{x_{2,0}^2} \\ -1 & 0 & 0 & 0 \end{bmatrix} \quad (96)$$

For the previously chosen equilibrium point,  $\text{rank}(\mathbf{M}_{CK}) = \text{rank}(\mathbf{A}) = 2$  and thus the primary system is controllable.

Condition II

For the considered system,  $\text{rank}(\mathbf{u}) = 2$  and  $\text{rank}(\mathbf{y}) = 2$ , thus the condition is met. Since both conditions are met, the expanded system is controllable.

Manual tuning of matrices  $\mathbf{Q}$  and  $\mathbf{R}$  was performed based on simulation tests, which allowed to assess weight matrices' influence on control quality and performance of control system. The achieved values served as the initial values for optimization.

The assessment was conducted based on the properties of graphs (overshoot, settling time, rise time, maximum value, and change rate of control variables) and the values of integral performance indices (79a)–(79e).

For the  $f_{out}(t)=const$  system, the achieved values of matrices  $\mathbf{Q}$ ,  $\mathbf{R}$ ,  $\mathbf{F}$ , and  $\mathbf{F}_i$  were as follows:

$$\mathbf{Q} = \begin{bmatrix} 2 & 0 & 0 & 0 \\ 0 & 3 & 0 & 0 \\ 0 & 0 & 10 & 0 \\ 0 & 0 & 0 & 10 \end{bmatrix}; \quad \mathbf{R} = \begin{bmatrix} 1 & 0 \\ 0 & 0.1 \end{bmatrix} \quad (97a)$$

$$\mathbf{F} = \begin{bmatrix} 0 & 3.0536 \\ 13.8661 & 0 \end{bmatrix}; \quad \mathbf{F}_i = \begin{bmatrix} 0 & 3.0536 \\ 10 & 0 \end{bmatrix} \quad (97b)$$

For the  $f_{in}(t)=const$  system, the results were

$$\mathbf{Q} = \begin{bmatrix} 3 & 0 & 0 & 0 \\ 0 & 1 & 0 & 0 \\ 0 & 0 & 10 & 0 \\ 0 & 0 & 0 & 3 \end{bmatrix}; \quad \mathbf{R} = \begin{bmatrix} 2 & 0 \\ 0 & 0.1 \end{bmatrix} \quad (98a)$$

$$\mathbf{F} = \begin{bmatrix} 0 & -1.7174 \\ 14.1987 & 0 \end{bmatrix}; \quad \mathbf{F}_i = \begin{bmatrix} 0 & -1.2247 \\ 10 & 0 \end{bmatrix} \quad (98b)$$

Then, in order to find optimal  $\mathbf{Q}$  and  $\mathbf{R}$  weight matrices and, in consequence, optimal  $\mathbf{F}$  and  $\mathbf{F}_i$  gain matrices, optimization was performed using integral performance indices of control (79a)–(79e).

The process variables  $C(t)$  and  $V(t)$  were chosen as objective functions for optimization. Weights of matrices  $\mathbf{Q}$  and  $\mathbf{R}$  ( $Q_1, Q_2, Q_3, Q_4, R_1, R_2$ ) were chosen as decision variables.

Constraints

$$Q_1 \geq 0; \quad Q_2 \geq 0; \quad Q_3 \geq 0; \quad Q_4 \geq 0; \quad R_1 > 0; \quad R_2 > 0 \quad (99)$$

The constraints are a consequence of LQR's properties, from which stem the following conditions:

- the  $\mathbf{Q}$  matrix must be positive semidefinite;
- the  $\mathbf{R}$  matrix must be positive definite.



Optimization was performed using the method of minimizing the maximum out of a set of objective functions (the same as in Section 3.1.3) [16].

For the  $f_{out}(t)=const$  system, the lowest integral performance index values for both control variables and the best control quality in terms of settling time and overshoot were achieved for the ITAE index. The optimal values for  $Q$ ,  $R$ ,  $F$ , and  $F_i$  matrices are

$$Q = \begin{bmatrix} 10^{-6} & 0 & 0 & 0 \\ 0 & 0.1309 & 0 & 0 \\ 0 & 0 & 12.04 & 0 \\ 0 & 0 & 0 & 10.88 \end{bmatrix};$$

$$R = \begin{bmatrix} 10^{-6} & 0 \\ 0 & 10^{-6} \end{bmatrix} \quad (100a)$$

$$F = \begin{bmatrix} 0 & 370.7667 \\ 262.4497 & 0 \end{bmatrix}; F_i = \begin{bmatrix} 0 & 3298.0 \\ 3470.2 & 0 \end{bmatrix} \quad (100b)$$

For the  $f_{in}(t)=const$  system, analogically, the lowest integral performance index values were achieved for the ISE index. The optimal values for  $Q$ ,  $R$ ,  $F$ , and  $F_i$  matrices are:

$$Q = \begin{bmatrix} 10^{-6} & 0 & 0 & 0 \\ 0 & 0.3995 & 0 & 0 \\ 0 & 0 & 0.1092 & 0 \\ 0 & 0 & 0 & 4.528 \end{bmatrix};$$

$$R = \begin{bmatrix} 0.0113 & 0 \\ 0 & 10^{-6} \end{bmatrix} \quad (101a)$$

$$F = \begin{bmatrix} 0 & -8.6885 \\ 256.1044 & 0 \end{bmatrix}; F_i = \begin{bmatrix} 0 & -20.0 \\ 3305.0 & 0 \end{bmatrix}. \quad (101b)$$

### 3.3. Fuzzy control system

A fuzzy logic controller (FLC) is used for calculating control variables. A fuzzy model consists of three blocks: fuzzification, inference (with rule base), and defuzzification (see Fig. 5), where  $e_c(t)$ ,  $dec(t)/dt$ ,  $ev(t)$ , and  $dev(t)/dt$  are control error of  $C(t)$ , derivative control error of  $C(t)$ , control error of  $V(t)$ , and derivative control error of  $V(t)$ , respectively;  $\mu_{NL}(ec)$ ,  $\mu_{NS}(ec)$ , and  $\mu_{NP}(ev)$  are membership degrees of FLC's input variables;  $\mu_{ZO}(f_{in})$ ,  $\mu_{SO}(f_{in})$ , and  $\mu_L(C_{in})$  are membership degrees of FLC's output variables.

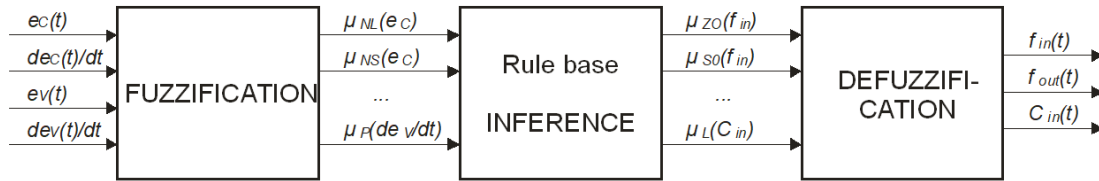

Fig. 5. Block diagram of fuzzy controller

The purpose of fuzzification is to determine a membership degree for individual fuzzy sets of input functions of the system. It is necessary to define the membership function for every input variable. Fuzzy inference comes down to calculating result membership functions of the conclusions (output variables of the system) based on the evaluation of the degree of membership for individual input variables. It is achieved based on a rule base, which is a set of relationships existing between input and output fuzzy sets of the system. The rules, which constitute the rule base, can take the following form:

$$R_1: \text{IF } (x_1 = A_1) \text{ AND } (x_2 = B_1) \text{ THEN } (y = C_1), \quad (102)$$

where  $x_1$ ,  $x_2$  are input variables of the system,  $y$  is output variable of the system,  $A_1$ , and  $B_1$  are fuzzy sets of input variables, and  $C_1$  is a fuzzy set of the output variable.

The purpose of defuzzification is to calculate fuzzy and sharp values based on the result membership functions of conclusions, according to a chosen criterion, e.g., the center of gravity (COG) method. The acquired output value of the system is a number, for instance, a specific voltage value on the output of FLC [17, 18].

In practical application of the fuzzy modeling, often, instead of the formal approach, a simplified approach is applied, for example, a simplified Mamdani inference system, which was applied in this research. It consists of the following stages and fuzzy sets operations [19]: intersection—t-norm MIN, union—t-norm MIN, implication—t-norm MIN, aggregation—s-norm MAX, defuzzification—COG.

The following variables were defined as input variables of the fuzzy controller: control error of  $C(t)$  is  $ec(t)$ , derivative control

error of  $C(t)$  is  $dec(t)/dt$ , control error of  $V(t)$  is  $ev(t)$ , and derivative control error of  $V(t)$  is  $dev(t)/dt$ . Derivative control error enables the evaluation of rate and sign of control error change. The control variables  $f_{in}(t)$ ,  $f_{out}(t)$ , and  $C_{in}(t)$  were defined as output variables of the fuzzy controller. Gains  $K_{CP}$ ,  $K_{CD}$ ,  $K_{VP}$ , and  $K_{VD}$  were implemented in the tracks of FLC's input variables. Their purpose is to adjust the input signals to the range defined for individual inputs of the FLC. Chosen gain values were  $K_{CP} = 14$ ,  $K_{CD} = 0.025$ ,  $K_{VP} = 15$ , and  $K_{VD} = 0.1$ . Additionally, the dead zone algorithm was applied after the operation of derivation in order to improve the calculation efficiency. The control system and the fuzzy controller were developed gradually. At first, gains for FLC's inputs  $ev(t)$  and  $dev(t)/dt$  were found and a fuzzy inference system was developed for the process variable  $V(t)$ , without taking  $C(t)$  into consideration. As soon as a satisfactory performance for  $V(t)$  was achieved, the same steps were taken in regard to FLC's inputs  $ec(t)$  and  $dec(t)/dt$  and output  $C_{in}(t)$ . The control system's structure is shown in Fig. 6.

The linguistic values and membership function type of FLC's inputs are presented in Tab. 2. The range of all input variables is  $[-1, 1]$ .

In Tab. 3, the linguistic values and membership function type of FLC's inputs are presented. The range of the fuzzy variables  $f_{in}$  and  $f_{out}$  is  $[0, 1]$  [m<sup>3</sup>/s]. The range of the fuzzy variable  $C_{in}$  is  $[0, 25]$  [kmol/m<sup>3</sup>] because such range was assumed in the process of fuzzy controller design as the achievable range of component concentration. The linguistic values and membership functions for controllers output variable  $f_{out}$  are identical to those for  $f_{in}$ .

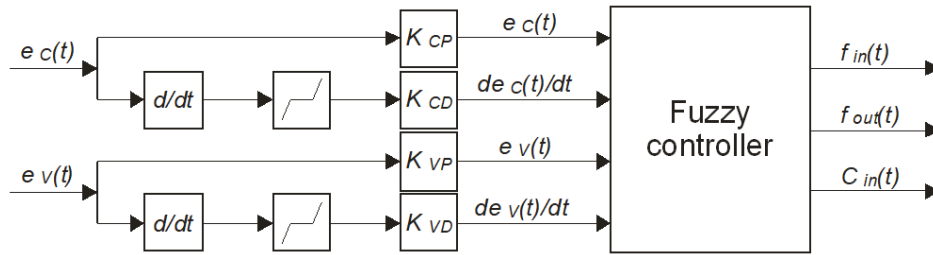

Fig. 6. FLC structure. FLC, fuzzy logic controller

Tab. 2. Linguistic values and membership functions for FLC inputs

Linguistic variable – error of C (eC)						
	Linguistic value		Membership function	Characteristic points		
1	Negative	N	L-function	-	-0.2	0
2	About zero	ZO	Symmetrical triangular	-0.08	0	0.08
3	Positive	P	R-function	0	0.2	-
Linguistic variable – derivative of error of C (deC/dt)						
	Linguistic value		Membership function	Characteristic points		
1	Negative	N	L-function	-	-0.2	0
2	About zero	ZO	Symmetrical triangular	-0.2	0	0.2
3	Positive	P	R-function	0	0.2	-
Linguistic variable – error of V (eV)						
	Linguistic value		Membership function	Characteristic points		
1	Negative large	NL	L-function	-	-0.45	0
2	Negative small	NS	Symmetrical triangular	-0.1	-0.05	0
3	About zero	ZO	Symmetrical triangular	-0.01	0	0.01
4	Positive small	AP	Symmetrical triangular	0	0.05	0.1
5	Positive large	LP	R-function	0	0.45	-
Linguistic variable – derivative of error of V (deV/dt)						
	Linguistic value		Membership function	Characteristic points		
1	Negative	N	L-function	-	-1	0
2	About zero	ZO	Symmetrical triangular	-0.02	0	0.02
3	Positive	P	R-function	0	1	-

FLC, fuzzy logic controller

Tab. 3. Linguistic values and membership functions for FLC outputs

Linguistic variable – inflow rate (f <sub>in</sub> )						
	Linguistic value		Membership function	Characteristic points		
1	About zero	ZO	L-function	-	0.05	0.2
2	Small	S0	Symmetrical triangular	0.14	0.2	0.26
3	Medium	M	Asymmetrical triangular	0.2	0.35	0.6
4	Large medium	LM	Asymmetrical triangular	0.5	0.6	0.8
5	Large large	LL	R-function	0.6	0.8	-
Linguistic variable – concentration (C <sub>in</sub> )						
	Linguistic value		Membership function	Characteristic points		
1	About zero	ZO	L-function	-	0	4.9
2	Small	S0	Symmetrical triangular	4.5	5	5.5
3	Large	L	R-function	5.1	10	-

FLC, fuzzy logic controller

The rule base was based on the tables of connections between FLC's inputs and outputs for the variable  $V(t)$  (see Tab. 4) and for the variable  $C(t)$  (see Tab. 5). The tables facilitated taking the connection between all pairs of input values and all output

values into consideration while creating the rule base. The linguistic values in Tabs. 4 and 5 are presented in the form  $f_{in}/f_{out}$ .

In order to reduce the settling time of  $C(t)$ , especially in the case of the negative step of the reference value, a modification

was applied to the rule base. Rules which in case of steady volume  $V(t)$  increase both inflow and outflow of the substance were added. The aim of the modification was to accelerate achieving the reference value of  $C(t)$  through removing the substance of incorrect  $C(t)$  value while maintaining a constant value of  $V(t)$ .  $V(t)$  in steady state was a premise for these rules, because the increase of  $f_{in}(t)$  and  $f_{out}(t)$ , while the value of  $V(t)$  was changing, resulted in an extension of the settling time of this variable. The rule base was extended by three additional rules:

$$R_{25}: \text{IF } (e_c = P) \text{ AND } (e_v = ZO) \text{ AND } (de_v/dt = ZO) \text{ THEN } (f_{in} = LL)(f_{out} = LL) \quad (103a)$$

$$R_{26}: \text{IF } (e_c = N) \text{ AND } (e_v = ZO) \text{ AND } (de_v/dt = ZO) \text{ THEN } (f_{in} = LL)(f_{out} = LL) \quad (103b)$$

$$R_{27}: \text{IF } (e_c = ZO) \text{ AND } (e_v = ZO) \text{ AND } (de_v/dt = ZO) \text{ THEN } (f_{in} = M)(f_{out} = M) \quad (103c)$$

Tab. 4. Rules of the fuzzy controller regarding  $C(t)$

Inputs	Linguistic variable	deV/dt		
	Linguistic value	N	ZO	P
eV	NL	ZO/LL	ZO/LM	ZO/LM
	NS	S/LM	S/M	S/M
	ZO	S/S	S/S	S/S
	PS	M/S	M/S	LM/S
	PL	LM/ZO	LM/ZO	LL/ZO

Tab. 5. Rules of the fuzzy controller regarding  $V(t)$

Inputs	Linguistic variable	deC/dt		
	Linguistic value	N	ZO	P
eC	N	ZO	ZO	S0
	ZO	S0	S0	S0
	P	S0	L	L

#### 4. CONTROL RESULTS AND DISCUSSION

Best values of integral indices for the best controller type (PI) with optimal constants in both configurations of the system were presented in Tab. 6. For the  $f_{out}(t)=const$  system, as well as the  $f_{in}(t)=const$  system, the lowest index values, and the most advantageous graphs were achieved for the IE criterion.

Tab. 6. Integral performance index values for control using PI controllers

Performance index	Control value	$f_{out}(t)=const$	$f_{in}(t)=const$
IAE	C	1.242E-02	2.258E-02
	V	1.304E-02	5.000E-02
ISE	C	1.170E-03	1.027E-03
	V	5.379E-04	1.670E-03
ITAE	C	1.997E-03	1.410E-03
	V	1.997E-03	2.505E-02
IE	C	2.799E-06	2.517E-06
	V	-2.561E-15	-2.465E-12

PI, proportional-integral

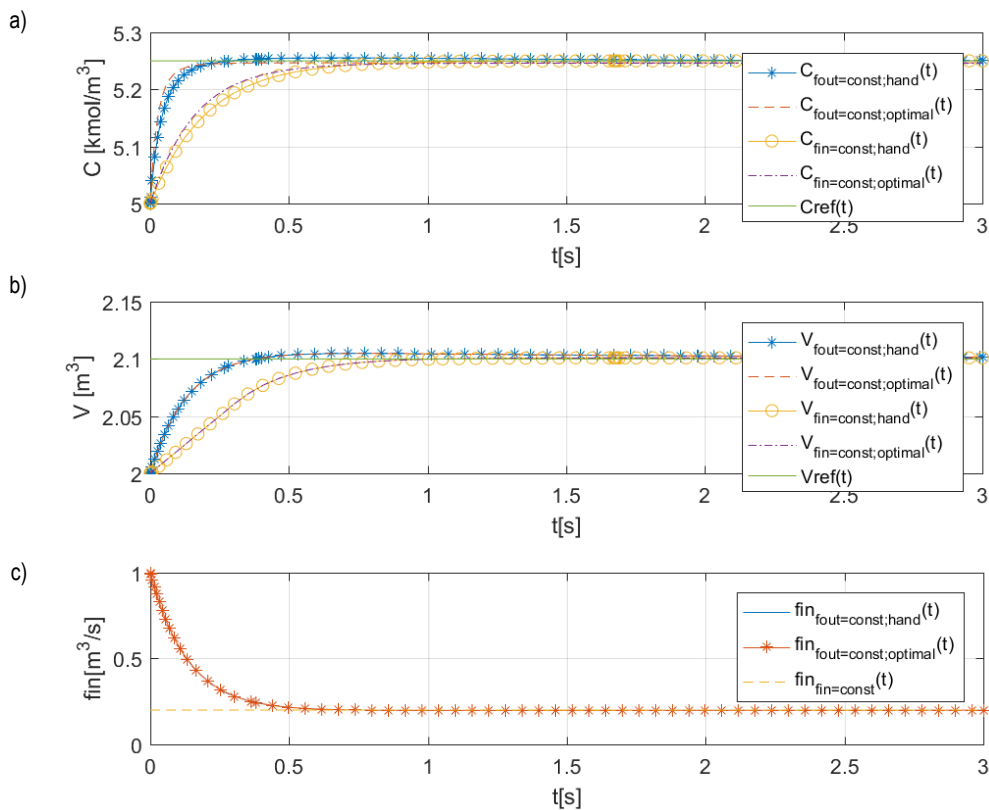

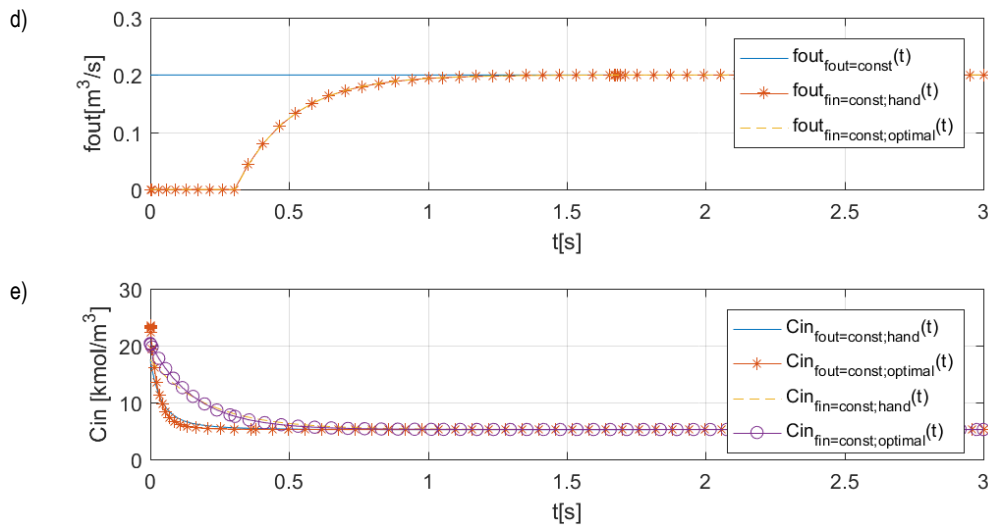

Fig. 7. Control results (multivariable PID) for  $f_{out}(t)=const$  system and for  $f_{in}(t)=const$  system

The control results of multivariable PID control with constants chosen by hand and by optimization were presented in Fig. 7. The optimal control with constant  $f_{out}(t)$  ensured shorter settling and rise time and allowed to avoid control signals' wind-up (Figs. 7a, b). However, it also caused the process value  $V(t)$  to overshoot (see Fig. 7b). Moreover, for the  $f_{in}(t) = const$  system, the control signal  $f_{out}(t)$  entered a long state of saturation (see Fig. 7d), which is an undesirable effect. For the  $f_{out}(t) = const$  system, the control signal  $f_{in}(t)$  came close to the end of its range, although it did not reach it (see Fig. 7c). The optimization enabled to achieve shorter settling and rise time of  $C(t)$  (Fig. 7a).

The graphs of process and control values for the best values of  $Q$  and  $R$  matrices, which had been selected, tuned manually (98a), (99a) and achieved in the process of optimization (100a), (101a) for the  $f_{out}(t)=const$  system and for the  $f_{in}(t)=const$  system were compared. By far, the best results were achieved for the version with constant substance outflow—settling time of variables  $C(t)$  (Fig. 8a) and  $V(t)$  (Fig. 8b) was significantly shorter and the

control signal  $C_{in}(t)$  (Fig. 8e) is significantly less demanding compared with the  $f_{in}(t)=const$  configuration. The reason for this is that in the nonlinear model of the averaging tank, the variable  $f_{in}(t)$  influences the rate of change of concentration  $C(t)$  both directly and through the change of volume  $V(t)$ , while the variable  $f_{out}(t)$  influences only the change of  $V(t)$ , which then influences  $C(t)$ . The advantage is prominent, especially in Fig. 8b, which presents settling time approx. 3 times shorter than in the case of  $f_{in}(t)=const$ . The optimization improved the control system's performance for both configurations. It is indicated by the values of integral performance indices as well (see Tab. 7). The indices are in all instances lower for the  $f_{out}(t)=const$  system than for the  $f_{in}(t)=const$  system and they are lower for optimal  $Q$  and  $R$  matrices compared to the results of manual tuning (with the exception of ISEG). The only reservation is that the maximum values of control variables— $f_{in}(t)$  in the  $f_{out}(t)=const$  system (Fig. 8c),  $f_{out}(t)$  in the  $f_{in}(t)=const$  system (Fig. 8d), and  $C_{in}(t)$  in the  $f_{out}(t)=const$  system (Fig. 8e) have increased visibly.

Tab. 7. Integral performance index values for  $f_{out}(t)=const$  system and for  $f_{in}(t)=const$  system (IC control system)

Performance index	Control value	$f_{out}(t)=const$ ; hand	$f_{out}(t)=const$ ; optimal	$f_{in}(t)=const$ ; hand	$f_{in}(t)=const$ ; optimal
IAE	C	0.398	0.019	0.415	0.022
	V	0.098	0.011	0.149	0.043
ISE	C	0.064	0.003	0.068	0.004
	V	0.006	0.001	0.010	0.003
ITAE	C	0.481	0.001	0.510	0.002
	V	0.067	0.001	0.161	0.014
IE	C	0.372	0.019	0.380	0.019
	V	0.097	0.011	0.140	0.043
ISEG	C	156.073	156.200	156.078	156.202
	V	24.969	24.981	24.972	24.968

IC, integral control

The control results for the fuzzy control system were shown in Fig. 9. The settling time and the rise time (Fig. 9a, b) were short and overshoot did not occur. The graph of  $C(t)$  (Fig. 9a), in particular, achieves the reference value faster than for other control system structures. The control values (Fig. 9c and d) did not reach their limit values. Moreover, the margin separating the control signals from saturating was sufficient, which was not true for PID

and IC control. The only reservation in the case of fuzzy control is that the change rates of control signals were very high, which may not be possible to achieve for a real-life control plant. The values of integral performance indices for fuzzy control were presented in Tab. 8. The values of the indices were smaller than for IC, which confirms the superiority of fuzzy control in this instance.

Tab. 8. Integral performance index values (fuzzy control system)

Performance index	Control value	Index value
IAE	C	8.80E-02
	V	8.73E-03
ISE	C	1.42E-03
	V	5.75E-04
ITAE	C	2.22E-04
	V	5.15E-04
IE	C	8.82E-03
	V	8.73E-03

According to Figs. 7–9 and the values of performance indices in Tabs. 6–8, fuzzy control ensured the best performance of the system, with the most advantageous graphs of control variables. The settling time for both process variables was significantly shorter than for IC, which also allowed for good results. Multivariable PID control gave the worst results from among the designed algorithms. It is in line with expectations because a PID controller is dedicated to linear SISO systems and the considered system is nonlinear and MIMO. A fuzzy control system is a control method dedicated, among others, for nonlinear systems. It may be the cause of the advantage over IC, which in deviation from the adopted operating point did not give as good a result.

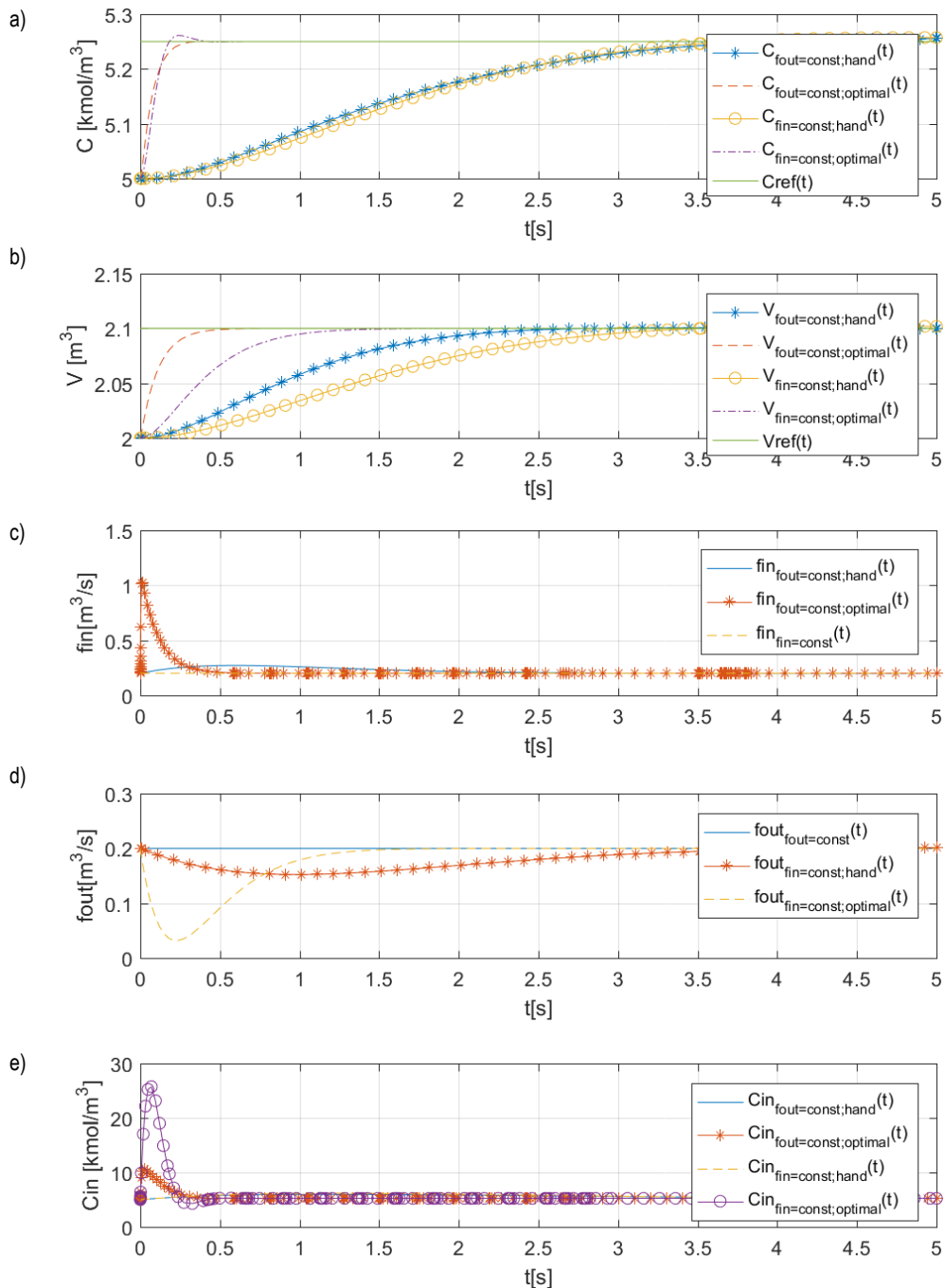

Fig. 8. Control results (IC control system) for  $f_{out}(t)=const$  system and for  $f_{in}(t)=const$  system

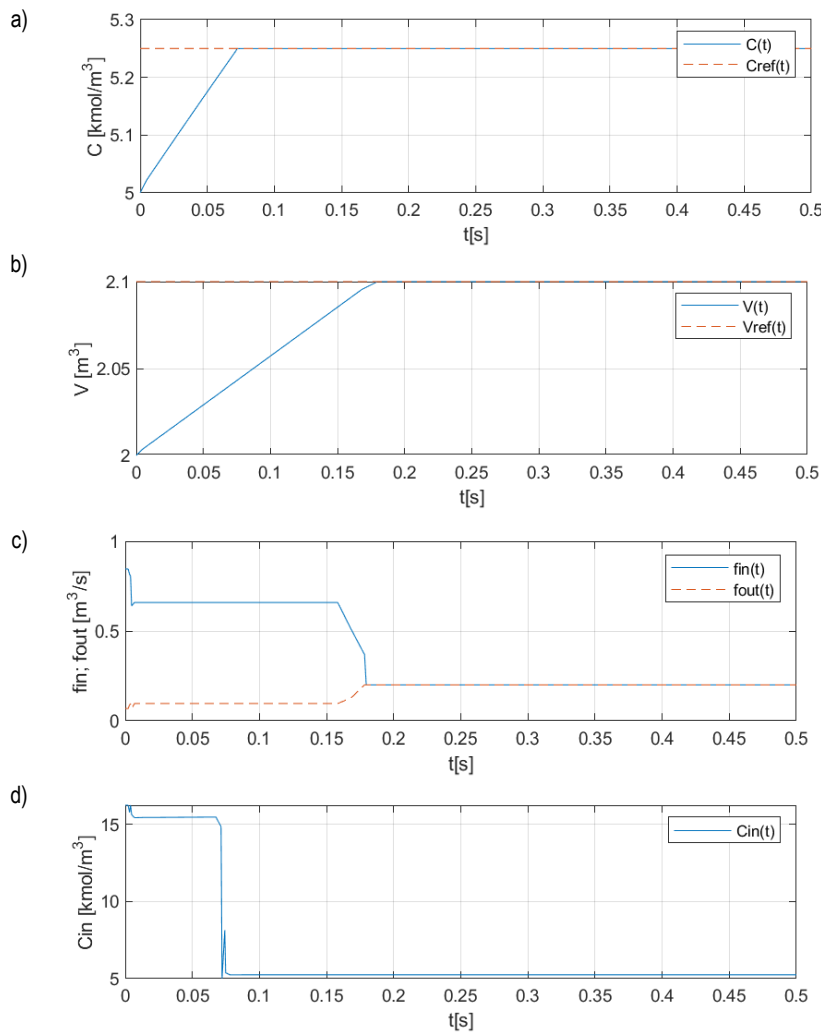

Fig. 9. Control results for fuzzy control system

## 5. CONCLUSIONS

This paper presented the modeling and control of an averaging tank with variable filling. The aim of the designed control system was to ensure zero steady-state error and quick response with minimal overshoot. Three control systems were designed. Multivariable PID control was developed using optimization for tuning the two PID controllers. The IC structure was designed using LQR for calculating gain matrices and optimization for calculating LQR weight matrices. Both multivariable PID and IC were developed in two versions: with  $f_{out}(t)=const$  and with  $f_{in}(t)=const$ . The control structure with FLC is using a Mamdani inference system. A series of simulation tests of the control system (in two versions of multivariable PID and IC) allowed to assess the performance of the system. Despite the fact that the control systems using PID and IC were designed based on the linearized model and tested on the nonlinear model of the control system, the result performance was good in the case of IC and decent for PID. However, due to the nonlinearity of the control system, as the reference values deviated significantly from the assumed equilibrium point, the systems' performance declined. Because fuzzy control is an adequate control method for MIMO and nonlinear control systems, it assured the best performance amongst the three designed algorithms.

The results presented in this paper may be used to synthesize a control system for a physical nonlinear MIMO system. In order

to do that, a modification of the equilibrium point assumed in the stage of linearization would be necessary to ensure its consistency with the physical properties of a control system. Additionally, adequate actuators and transport delays should be considered in the model. The design methodology of control algorithms presented in the paper allows performing calculation necessary to acquire parameters of these algorithms for the modified control system model.

An average Programmable Logic Controller (PLC) would be sufficient hardware to implement multivariable PID control and IC. Although not crucial, it would be helpful if the programming environment of the PLC handled matrix operations. When it comes to FLC, it is also possible to implement it in a PLC, although the program may exceed the controller's capabilities, causing a necessity to extend the execution period of the code. However, it is recommended that FLC is implemented in a PLC dedicated to fuzzy control, in an industrial PC (IPC) or a microcomputer dedicated for industrial applications. Before implementing a physical control system, the control algorithms should be tested and adjusted in hardware in the loop (HIL) simulation.

The issue of decline in the performance of multivariable PID and IC, which is caused by deviation from the assumed equilibrium point, may be resolved by determining control parameters for multiple equilibrium points and using them in the gain scheduling method. Another method that would resolve this issue is the cyclic calculation of control parameters for a linearized control system



model whose parameters vary according to the current equilibrium point (nonstationary model).

## REFERENCES

1. Spellman FR. Handbook of Water and Wastewater Treatment Plant Operations. CRC Press LLC, Boca Raton, FL. 2003.
2. Astrom KJ, Hagglund T. PID Controllers: Theory, Design and Tuning. 2nd ed. Instrument Society of America, Research Triangle, NC. 1995.
3. Rojas–Moreno A, Parra–Quispe A. Design and Implementation of a Water Tank Control System Employing a MIMO PID Controller. Faculty of Electrical and Electronic Engineering, National University of Engineering Lima. 2008.
4. Johansson KJ. The Quadruple-Tank Process: A Multivariable Laboratory Process with an Adjustable Zero. IEEE Transactions On Control Systems Technology 2000;8(3): 456-465.
5. Saeed Q, Uddin V, Katebi R. Multivariable Predictive PID Control for Quadruple Tank, World Academy of Science, Engineering and Technology. 2010;12: 861-866.
6. Meenatchi Sundaram S, Venkateswaran PR. Smith Predictor Implementation of a High Dead Time Interacting Tank Process. International Conference on Recent Innovations in Electrical, Electronics & Communication Engineering (ICRIEECE), 27-28 July, Bhubaneswar, India. 2018.
7. Janani S. Design of Integral Constant State Feedback Controller Using Ackermann's Function, IOSR Journal of Electronics and Communication Engineering (IOSR-JECE). 2014;9(1): 58-63.
8. Bojan-Dragos C, Hedrea E, Precup R, Szedlak-Stinean A, Roman R. MIMO Fuzzy Control Solutions for the Level Control of Vertical Two Tank Systems. Proceedings of the 16th International Conference on Informatics in Control, Automation and Robotics (ICINCO 2019), SCITEPRESS, 29-31 July, Prague, Czech Republic. 2019: 810-817.
9. Berk P, Stajko D, Vindis P, Mursec B, Lakota M. Synthesis water level control by fuzzy logic. Journal of Achievements in Materials and Manufacturing Engineering. 2011; 45(2): 204-210.
10. Kolankowski M, Piotrowski R. Synthesis of a state feedback controller for an averaging tank with variable filling. XXVI Scientific and Technical Conference Automation - News and Perspectives – AUTOMATION 2022, 25-27 May, Warsaw, Poland (in print). 2022.
11. Close CM, Frederick DK, Newell JC. Modeling and analysis of dynamic systems. 3rd ed. John Wiley & Sons, Hoboken, NJ. 2017.
12. Skogestad S, Postlethwaite I. Multivariable Feedback Control: Analysis and design. 2nd edition. John Wiley & Sons, Hoboken, NJ. 2005.
13. fminmax, <https://se.mathworks.com/help/optim/ug/fminimax.html>, (access: 18.10.2021).
14. Naidu DS. Optimal Control Systems. CRC Press, Boca Raton, FL. 2003.
15. Kwakernaak H, Sivan R. Linear Optimal Control Systems. John Wiley & Sons, Inc., Hoboken, NJ. 1972.
16. Murray RM. Optimization-Based Control. California Institute of Technology, Pasadena, CA. 2008.
17. Passino KM, Yurkovich S. Fuzzy Control. Addison Wesley Longman, Inc, Menlo Park, CA. 1998.
18. Jantzen J. Foundations of Fuzzy Control. John Wiley & Sons, Inc., Hoboken, NJ. 2007.
19. Mamdani EH. Application of fuzzy algorithms for control of simple dynamic plant. Proceedings of the Institution of Electrical Engineers. 1974;121(12): 1585–1588.

Michał Kolankowski:  <https://orcid.org/0000-0003-4528-3449>

Robert Piotrowski:  <https://orcid.org/0000-0002-8660-300X>