

# THE ANALYSIS OF PIPELINE TRANSPORTATION PROCESS FOR CO<sub>2</sub> CAPTURED FROM REFERENCE COAL-FIRED 900 MW POWER PLANT TO SEQUESTRATION REGION

Andrzej Witkowski\*, Andrzej Rusin, Mirosław Majkut, Katarzyna Stolecka

Silesian University of Technology, Institute of Power Engineering and Turbomachinery,  
Konarskiego 18, 44-100 Gliwice, Poland

Three commercially available intercooled compression strategies for compressing CO<sub>2</sub> were studied. All of the compression concepts required a final delivery pressure of 153 bar at the inlet to the pipeline. Then, simulations were used to determine the maximum safe pipeline distance to subsequent booster stations as a function of inlet pressure, environmental temperature, thickness of the thermal insulation and ground level heat flux conditions. The results show that subcooled liquid transport increases energy efficiency and minimises the cost of CO<sub>2</sub> transport over long distances under heat transfer conditions. The study also found that the thermal insulation layer should not be laid on the external surface of the pipe in atmospheric conditions in Poland. The most important problems from the environmental protection point of view are rigorous and robust hazard identification which indirectly affects CO<sub>2</sub> transportation. This paper analyses ways of reducing transport risk by means of safety valves.

**Keywords:** carbon dioxide, capture and storage, compression processes, pipeline transportation, risk

## 1. INTRODUCTION

The CO<sub>2</sub> capture and storage chain is subdivided into four systems: the system of capture and compression, the transport system, the injection system and the storage system. The main objective of this paper is to analyse CO<sub>2</sub> compression and transportation systems. Among several approaches to the problem, CO<sub>2</sub> pipeline transportation is the most economical solution when it comes to transporting large amounts of CO<sub>2</sub> over a long distance (Det Norske Veritas, 2010, Incropera and DeWitt, 1996, Witkowski et al., 2013, Zhang et al., 2006). Pipeline transmission of CO<sub>2</sub> over longer distances is most efficient when CO<sub>2</sub> is in the dense phase (Fig. 1) i.e. in the liquid or supercritical regime, to increase the transport capability and reduce the capital cost of the pipeline system (Zhang et al., 2006).

This phase is preferable due to the fact it is relatively stable compared to the liquid state which minimises cavitation problems in components such as booster stations and pumps. Since the critical point for CO<sub>2</sub> is 31.1 °C and 7.38 MPa, a system pressure of more than 7.5 MPa will result in supercritical transportation, as long as the temperature stays above 31.1 °C. According to Fig.1 pressure drops below the critical level, the phase may be either liquid or gas or both depending on the local temperature. Gas phase transport is disadvantaged by low density and high pressure drop. Since the critical temperature is higher than the normal ground temperature, thermal insulation is needed to keep CO<sub>2</sub> at supercritical state, or CO<sub>2</sub> needs to be heated every certain distance, or else it will transform from the supercritical into the liquid state. Pressure losses and sufficient pipeline distances

\*Corresponding author, e-mail: andrzej.witkowski@polsl.pl

*cpe.czasopisma.pan.pl; degruyter.com/view/j/cpe*

taken into account in CO<sub>2</sub> transportation require compressor discharge pressure in the range of 130-200 bar. The CO<sub>2</sub> capture and storage chain is subdivided into four systems: the system of capture and compression, the transport system, the injection system and the storage system. The main objective of this paper is to analyse CO<sub>2</sub> compression and transportation systems. The first part presents an analysis of the processes related to the compression of CO<sub>2</sub> captured from flue gases of the concept 900 MW power plant intended for the firing of pulverised hard coal (Łukowicz et al., 2011) to the pressure value at the transporting pipeline inlet using as little energy as possible. Since CO<sub>2</sub> is a highly corrosive medium, the water content must be reduced to less than 60% of the saturation state (Mohitpour et al., 2012). In the case of intercooled compression, a portion of the moisture is removed by condensation. However, it is still necessary to provide further drying after the final compressor stage. The use of stainless steel for all components coming in contact with wet CO<sub>2</sub> eliminates the problem. Another problem analysed in this study is the transport of CO<sub>2</sub> by a pipeline from the compressor outlet site to the disposal site under heat transfer conditions (Dongjie Zhang et al., 2012). Simulations were made to determine maximum safe pipeline distance to subsequent booster stations depending on the inlet pressure, environmental temperature, thermal insulation thickness and ground level heat transfer conditions. From the point of view of environmental protection, the most important problem is to identify the hazards which indirectly affect CO<sub>2</sub> transportation in a strict and reliable manner. This identification is essential for effective hazard management. A failure of pipelines is usually caused by corrosion, material defects, ground movement or third party interference. After the rupture of the pipeline transporting liquid CO<sub>2</sub>, a large pressure drop will occur. The pressure will continue to fall down until the liquid becomes a mixture of saturated vapour/liquid. In the vicinity of the rupture, liquid CO<sub>2</sub> will escape and immediately vaporise and expand. The paper discusses the issues of discharge and atmospheric dispersion of CO<sub>2</sub>.

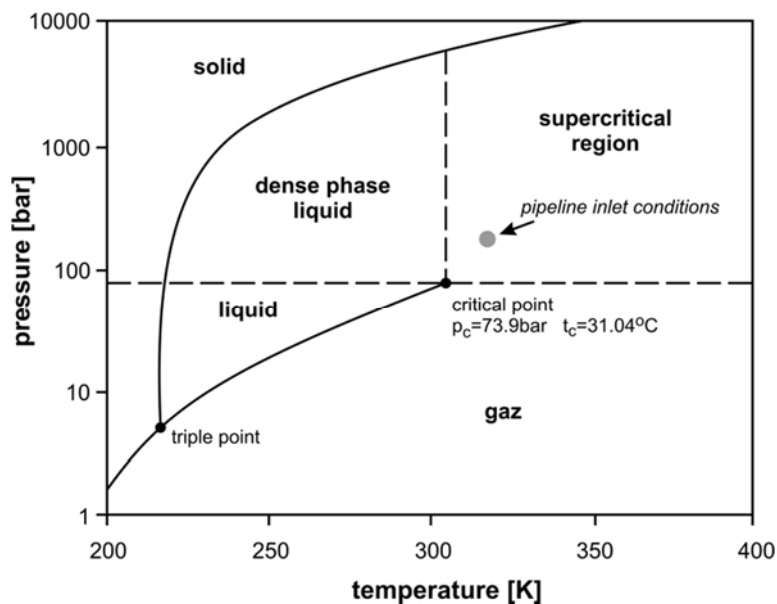

Fig. 1. A phase diagram for CO<sub>2</sub>

## 2. BOUNDARY CONDITIONS AND CHARACTERISTICS OF THE COMPRESSION PROCESS

### 2.1. Basic parameters of the power plant

The separation technology determines the thermodynamic state of carbon dioxide entering the process. In a typical post-combustion capture process based on chemical absorption, CO<sub>2</sub> is separated from the exhaust gas stream of the power plant at near-ambient conditions ( $t_1=35^\circ\text{C}$ ,  $p_1=1.5$  bar). The storage of

carbon dioxide is accomplished by drilling an injection well into a porous rock stratum or aquifer that is covered by a gas tight cap rock layer. The depth of such geologic formations varies with geographic locations but usually the final pressure of 136-204 bar is required to inject CO<sub>2</sub> into the underground formation. For this study, the maximum allowable operating pressure in the pipeline system of 153 bar was adopted in accordance with the ASME-ANSI 900# flanges (McCoy and Rubin, 2008). The compressor power was calculated for the following remaining conditions (Łukowicz et al., 2011):

- Power of PC plant 900 MW
- Mass flow of CO<sub>2</sub> 156.43 kg/s.
- Suction pressure 1.5 bar
- Discharge pressure 153 bar
- Cooling water temperature 19.1 °C
- Interstage cooling gas temperature: realistic – 35 °C
- Pressure loss in the coolers 1-3% ( $\Delta p_{\max} < 0.344$  bar)

These thermodynamic properties were used throughout the thermodynamic analysis to compare alternative options for the power required for the conventional process.

Additionally, in order to compare various options and provide accurate values for enthalpy, entropy and density, it was necessary to assume properties of pure carbon dioxide gas for the analysis.

## ***2.2. Establishing of CO<sub>2</sub> pipeline pressure***

In order to determine the operating pressure at the top of the well leading to underground reservoirs (Fig. 2), it is necessary to consider:

- the pressure at the bottom of the well to force CO<sub>2</sub> into the injection zone,
- pressure increase in the pipe due to the height of the CO<sub>2</sub> column,
- pressure loss due to the flow in the pipe.

To reduce difficulties in design and operation, it is generally recommended that a CO<sub>2</sub> pipeline should operate at a pressure higher than 9 MPa, where dramatic changes in CO<sub>2</sub> compressibility can be avoided across the range of temperatures that may be encountered in the pipeline system (McCoy, 2008). For sequestration purposes, CO<sub>2</sub> is generally injected to depths well over 1000 m (Mohitpour et al., 2012) - Fig. 2. Typically, the CO<sub>2</sub> injection pressure is about 9% to 18% above the in situ bottom value. Thus, at a 1000 m depth and the lowest acceptable pressure at the top of the wellhead and with the mean value of CO<sub>2</sub> density of 800 kg/m<sup>3</sup>, the required injection pressure will be 9.0 MPa + (1000 m depth × 800 kg/m<sup>3</sup>/100000 = 17 MPa. Taking into account 9% of pressure loss, the pressure at the ground reservoir will be 15.47 MPa).

## **3. REFERENCE OPTIONS OF COMPRESSION PROCESSES**

The objective of this study was to boost the pressure of CO<sub>2</sub> to pipeline pressure with the minimum amount of energy. In the centrifugal compressor market, two technologies are available, in-line centrifugal and integral-gear compressors. In reference to these, three various types of compressors, including a conventional multistage centrifugal compressor, an integrally geared compressor, and pump machines were used to the reference compression processes (Botero et al., 2009; Moore et al., 2008).

The process simulation Aspen Plus (Aspen Plus, Version 7.0, 2008) was used to predict thermodynamic properties of the CO<sub>2</sub> stream at required conditions and quantify the performance of each compression chain option. Within the Aspen environment, the Benedict, Web and Rubin with extension by Starling (BWRS) and Redlich and Kwong augmented by Soave (LKP) equation of state

for real gases within the relevant ranges of pressure and temperature for process compressor were used. The results for carbon dioxide are as follows: BWRs best agreement for  $p_{max} < 50$  bar (>99.8%), LKP best agreement for 50-250 bar (98%), (Ludtke, 2004).

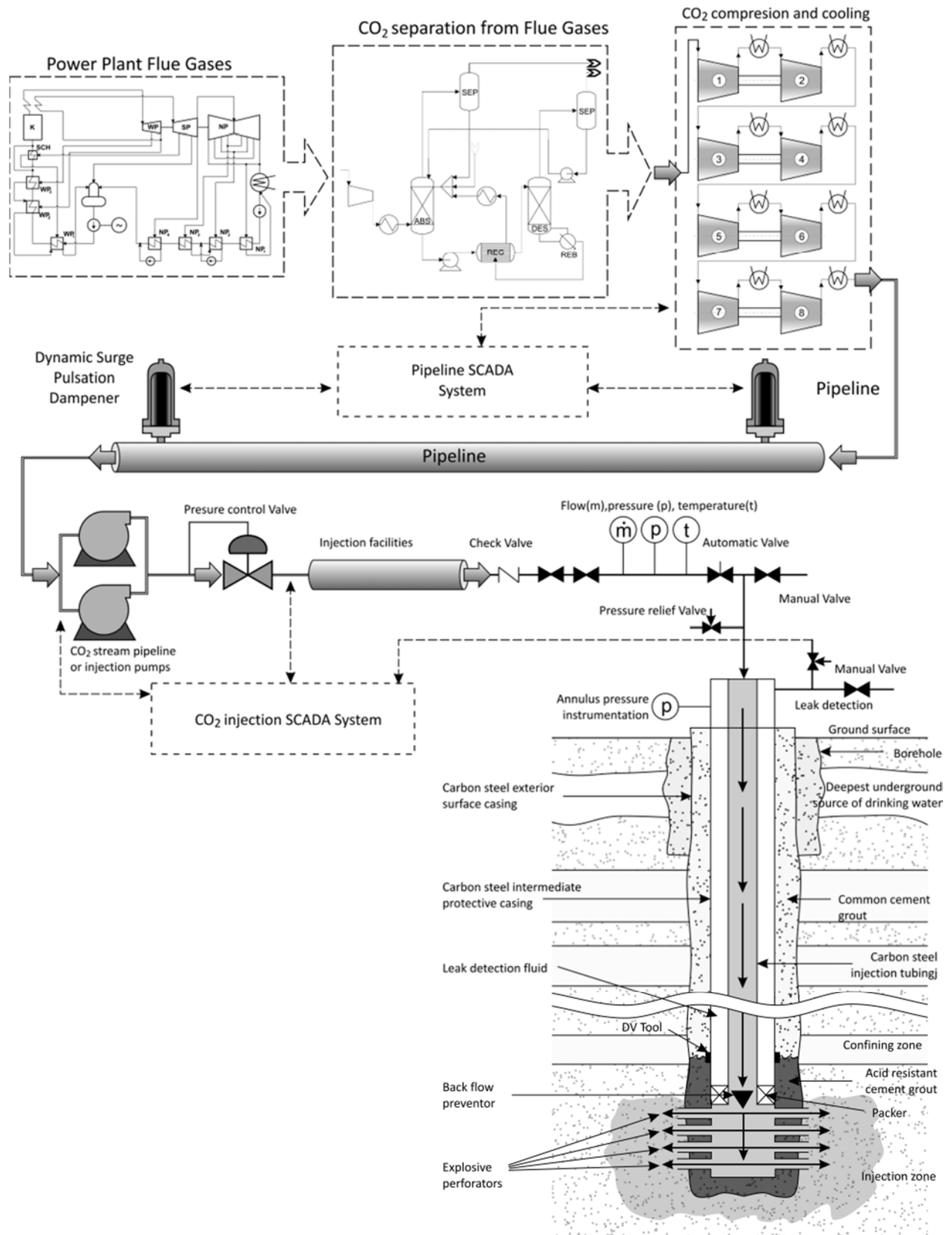

Fig. 2. Pipeline and sequestration systems for compression, transportation and injection of CO<sub>2</sub>; adapted from (Mohitpour et al., 2012)

### 3.1. Large multistage centrifugal compressor

The applied baseline thermodynamics analysis to which other alternatives were compared, the conventional two shaft approach which is characterised by four compressor sections with three intercoolers, 16 stage compression and no pump is schematically illustrated in Fig. 3.

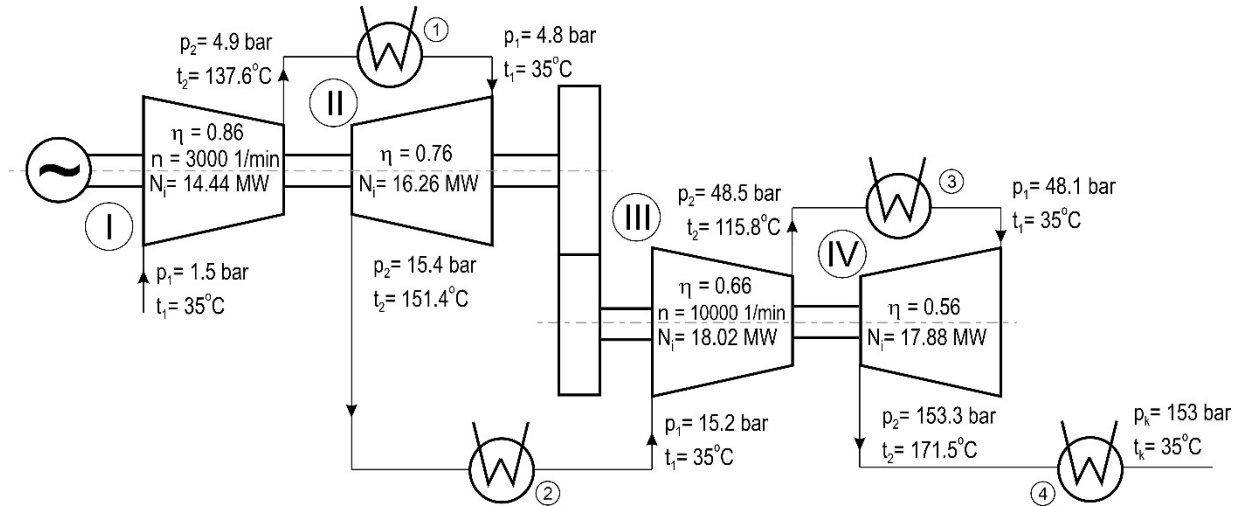

Fig. 3. Basic configuration of two shaft four section 16 stage radial compressor

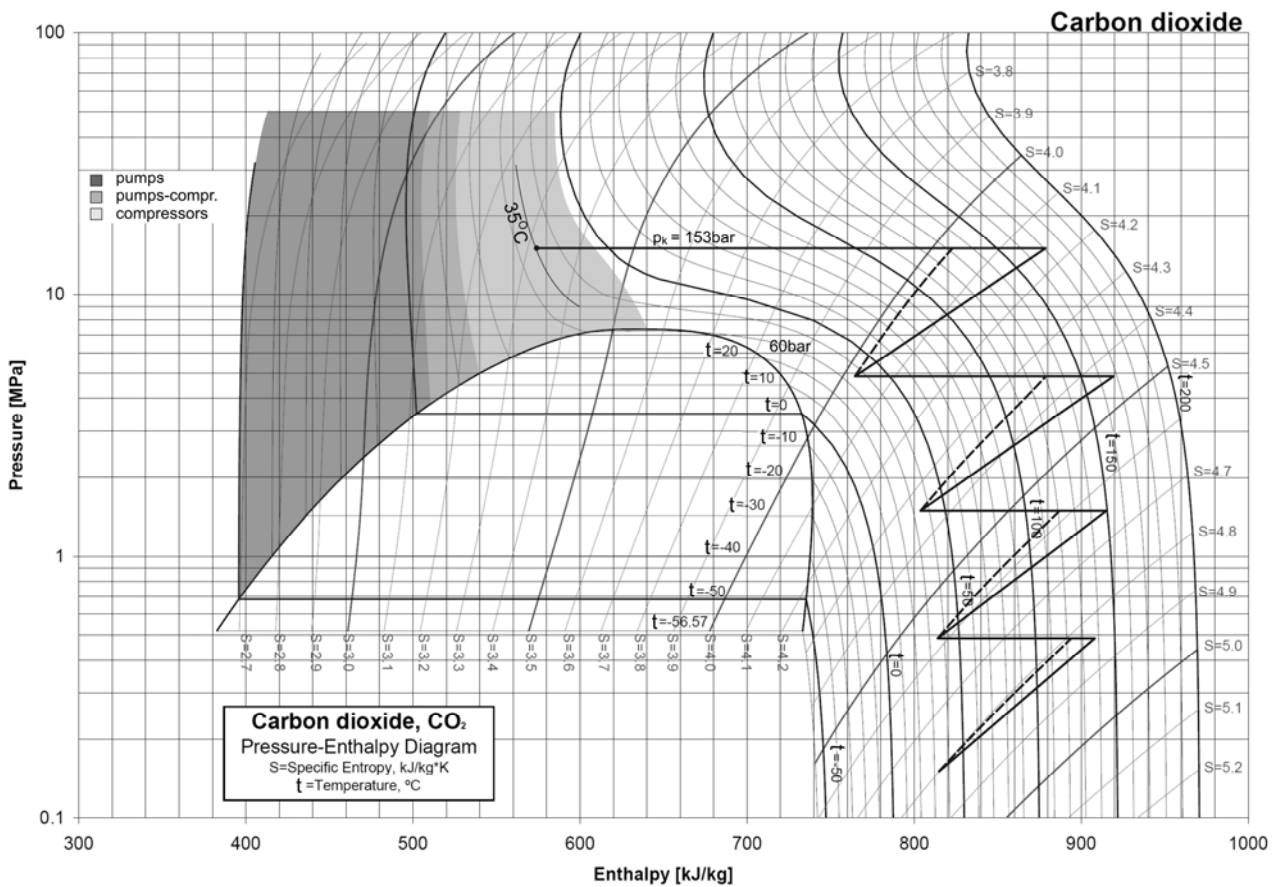

Fig. 4. Thermodynamic path of four section intercooling compression technology

For this study the polytropic efficiency of the multistage compressor was taken at 84% for the first section and linearly reduced in each successive section to 56% for the fourth section. The CO<sub>2</sub> stream

was brought to the final pressure value through four compression section intercooled to 35°C. The analysis so far assumes 19.1°C cooling water, typically fed from a cooling tower. The process is shown schematically in a pressure-enthalpy diagram (Fig. 4). This option provides a baseline to compare alternative compression options.

### 3.2. Eight-stage integrally geared compressor with intercoolers

Based on the literature (Bovon and Habel, 2007) we have come to the conclusion that for most CO<sub>2</sub> applications, the integral-gear design offers undeniable advantages over in-line centrifugal compressors:

- Integral-gear compressors have higher efficiency
- Optimum impeller flow coefficient, due to the fact an optimum speed can be selected for each pair of impellers
- Axial in-flow to each stage
- Intercooling possible after each stage
- Integral-gear compressors have comparable maintenance requirements as in-line compressors.
- Integral-gear compressors can be direct-driven by a 4-pole electric motor on the bull-gear, or a steam/gas turbine on one of the pinions.

Aerodynamic challenges include a very high pressure ratio of 1.7 to 2.0:1 and a wide range of flow coefficient for one stage. Eight stages of the integral-gear compressor with 7 intercoolers and inlet interstage gas temperature 35°C is required to reach pressure ratio 100:1 (Fig. 5). The efficiency of this compressor was taken as 84% for the first stage and nearly linearly reduced at each successive stage to 56% for the 8th stage (Koopman and Bahr, 2010). The thermodynamic path of the compression process is shown in Fig. 6.

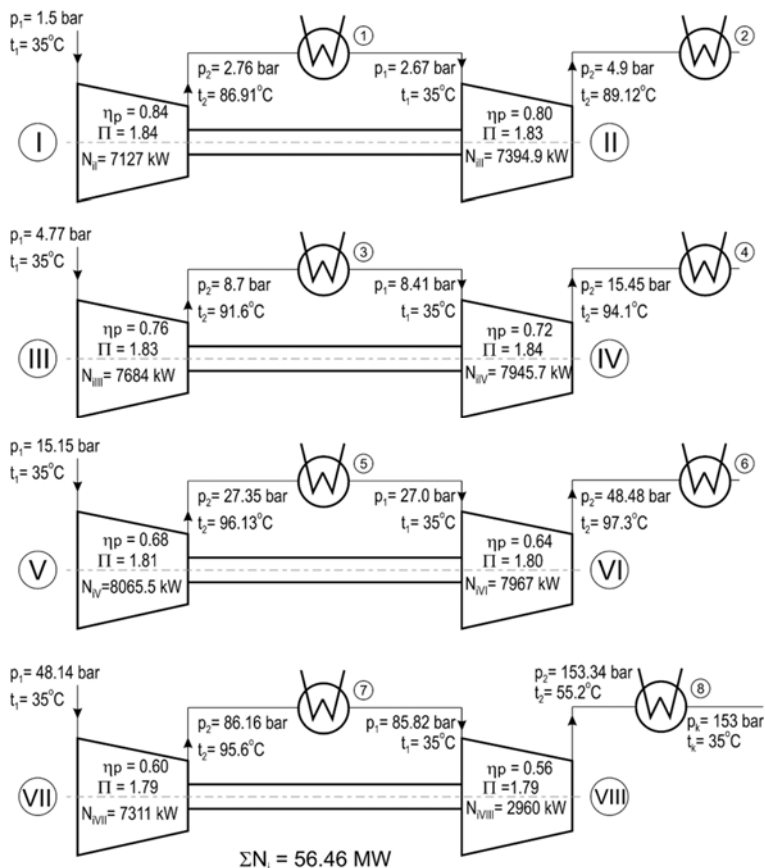

Fig. 5. Configuration of eight stage integrally geared compressor

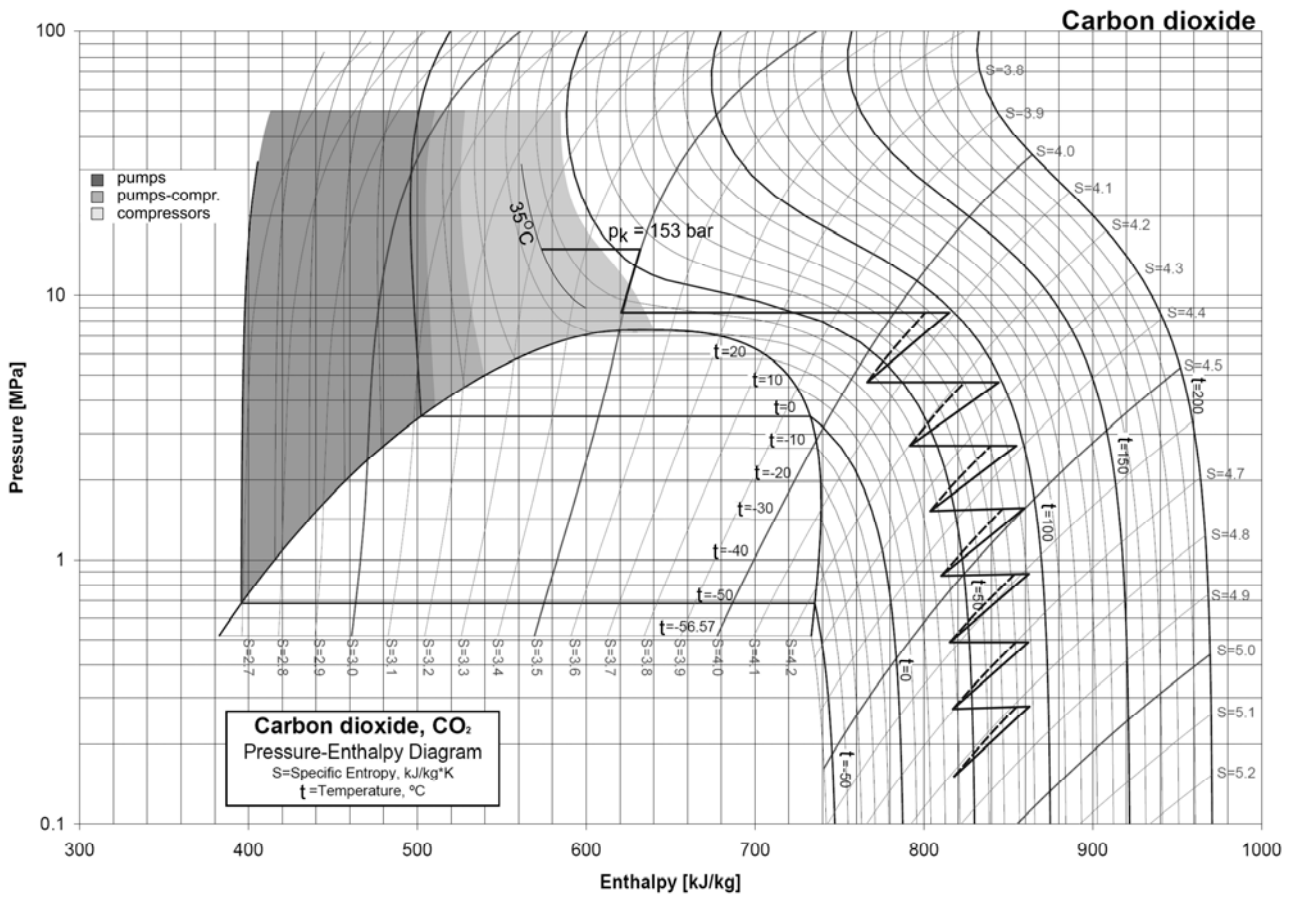

Fig. 6. Thermodynamic path of CO<sub>2</sub> compression of eight-stage integrally-gear compressor

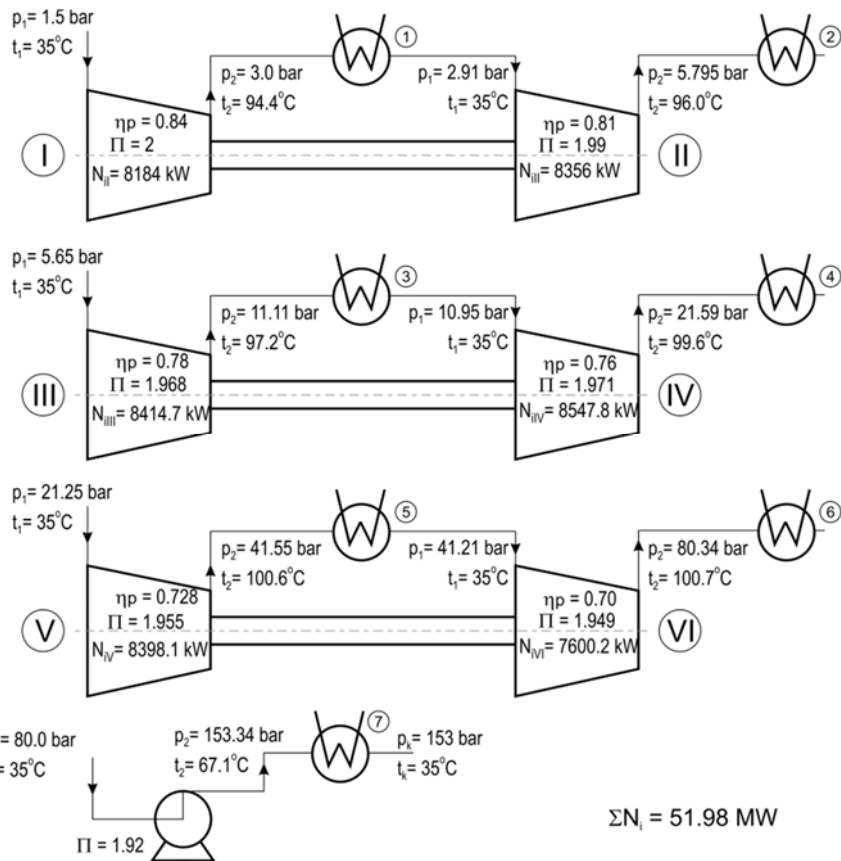

Fig. 7. Schematic illustration of compression and pumping with supercritical liquefaction

### 3.3. Compression and pumping

Power required for compression could be reduced if CO<sub>2</sub> were first compressed to an intermediate pressure, then cooled and liquefied, and the liquid then pumped to a higher pressure level required for pipeline injection. CO<sub>2</sub> is brought to just above the critical pressure (80 bar) through six compression sections intercooled to 35°C with water at ambient conditions. Subsequent cooling results in the liquefaction of CO<sub>2</sub> at the compressor outlet pressure of 80 bar, after which a pump is used to bring the dense fluid to the final pressure (Fig. 7). The thermodynamic path of the compression and pumping process is shown in Fig. 8.

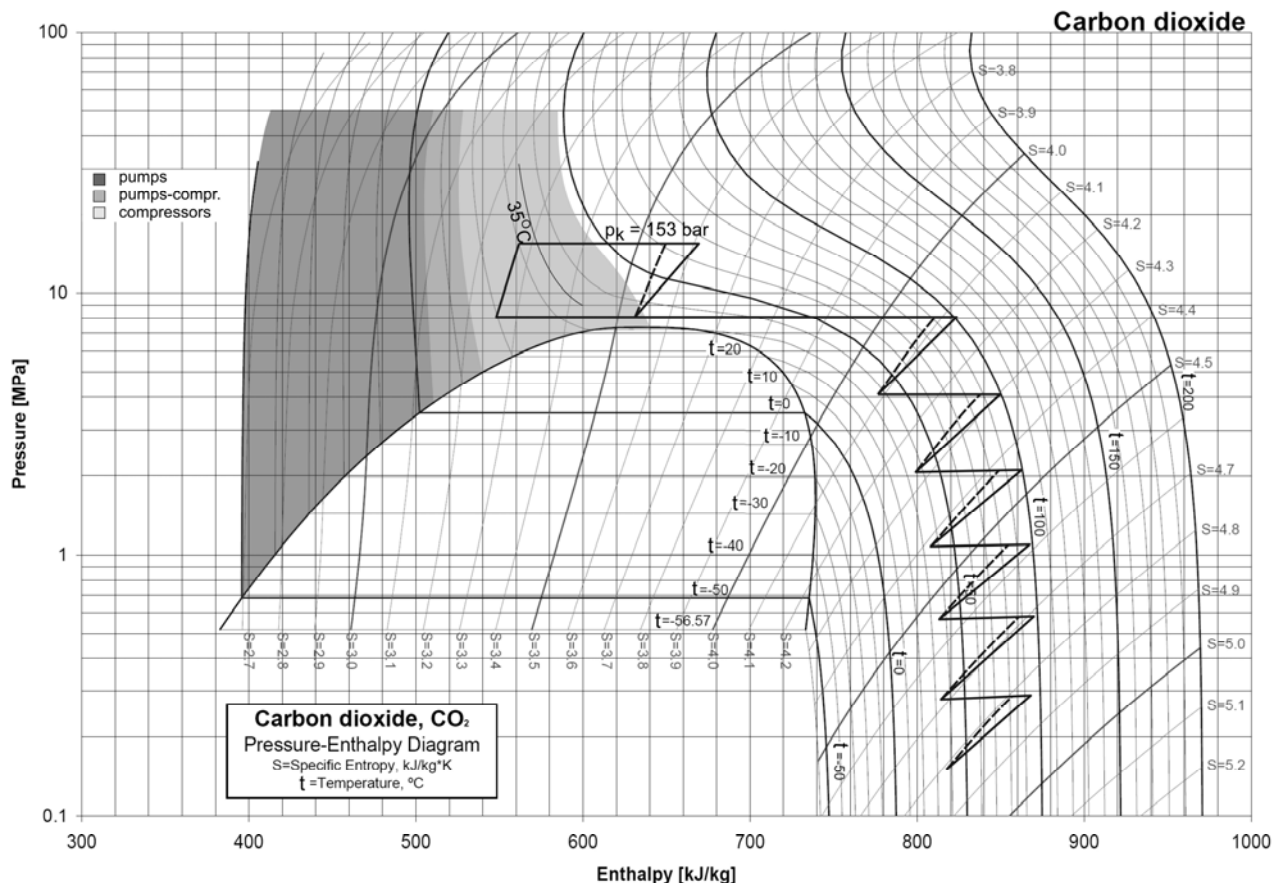

Fig. 8. Thermodynamic path of compression and pumping with supercritical liquefaction

Table 1. Comparison of compression technology options

Option	Compression technology	Process definition	Power requirements $N_i$ [kW]	% difference from option 1
1	Conventional centrifugal 16-stage six-section compressor	$p_1 = 1.5 \text{ bar}, p_2 = 153 \text{ bar}, t_1 = 35^\circ\text{C},$ interstage suction temp. $t_s = 38^\circ\text{C}$ polytropic efficiency $\eta_p = 85 - 56\%$	66602.6 kW	-
2	Eight-stage centrifugal geared compressor with 7 intercoolers	$p_1 = 1.5 \text{ bar}, p_2 = 153 \text{ bar}$ $t_1 = 35^\circ\text{C}, t_s = 35^\circ\text{C}$ polytropic efficiency $\eta_p = 86 - 56\%$	56456.6 kW	-15.23
3	Six-stage integrally geared compressor and pumping	$p_1 = 1.5 \text{ bar}, p_2 = 80 \text{ bar}$ $t_1 = 35^\circ\text{C}, t_s = 35^\circ\text{C}$ $\eta_p = 86 - 73\%$ $p_1 = 80 \text{ bar}, p_2 = 153 \text{ bar}$ $\eta_p = 80 \%$	51981.6 kW	-21.95



### **3.4. Summary of compression options**

The results for the cases 1-3 (Table 1) show that power requirements can be reduced by up to 15.23% with an integrally-gearred centrifugal compressor and by up to 21.95% with a centrifugal compressor followed by liquefaction and pumping, compared to the conventional compression process.

## **4. ANALYSIS OF TRANSPORTATION SYSTEMS FOR CO<sub>2</sub> SEQUESTRATION**

### **4.1. Introduction**

A commercially available ASPEN PLUS (2008) simulation program was used to determine the maximum safe pipeline distances to subsequent booster stations as a function of the CO<sub>2</sub> inlet pressure, environmental temperature and ground level thermal conditions, taking into consideration heat transfer conditions and using the pipe model. In the following discussion, the same power station data will be used as reported in Section 3 (Łukowicz et al., 2011, Witkowski et al., 2013). Since CO<sub>2</sub> temperature is usually higher than the ambient temperature if the gas is compressed and boosted above 9 MPa, the thermal insulation layer will slow down the CO<sub>2</sub> temperature decrease process, increasing the pressure drop in the pipeline. Therefore the thermal insulation layer should not be laid on the external surface of the pipe under the Polish atmospheric conditions.

Zhang et al. (2006) studied the pressure drop behaviour of supercritical CO<sub>2</sub> as well as the CO<sub>2</sub> dense phase along the pipeline. The results revealed that with the increased pipeline length its pressure drops, CO<sub>2</sub> evaporates and the pipeline can be blocked. If a need arises to transport CO<sub>2</sub> farther, boosting pump stations are needed along the pipeline. As concluded by the participants of the Workshop (Wolk, 2009), the currently available versions of the equations of state (EOS) to predict the properties of supercritical CO<sub>2</sub> under conditions close to the critical point are not reliable enough to design a compression system precisely. In the present work, in order to compare the results, two LKP and PRBM equations of state are used. The calculations were performed for carbon dioxide assumed as pure fluid. However, captured CO<sub>2</sub> will include a series of impurities depending on the capture technology, which has an effect on the CO<sub>2</sub> phase diagram. Moreover, in real CO<sub>2</sub> pipeline transportation, the pipeline may experience a change in elevation, which – although ignored until now – can have a great impact on the hydrodynamic performance. This work can be used as reference for the design and construction of CO<sub>2</sub> pipelines in Poland in the future.

### **4.2. Energy balance with surroundings**

#### **4.2.1. General remarks**

Any analysis of CO<sub>2</sub> transport by pipeline must take account of the influence of the ambient temperature on the heat exchange along the pipeline between carbon dioxide in the pipe and the surroundings. For subcooled liquid transmission and higher than critical temperatures, the pipeline may be buried and/or insulated in order to minimise heat gains. A buried and insulated pipeline will reduce the pressure drop and, therefore, energy losses in the system. However, the capital and maintenance costs will be higher. The pipeline needs not to be insulated if advantage can be taken of cold ground conditions, which maintain liquid conditions. According to engineering experience, long distance pipelines are usually buried at a depth of 1.2-1.5 m. Our own findings indicate that the annual lowest and highest soil temperatures 1.5 m underground in Poland are 5 °C and 16 °C, respectively.

In the pipeline design two cases with both the lowest and highest soil temperatures were considered to ensure that the pipeline could work well over a whole year. A two dimensional heat conduction formula (Incropera and DeWitt, 1996) has been used to calculate the heat exchange coefficient between the ground and CO<sub>2</sub> in the pipeline. For a pipeline with 0.05 m and 0.03 m heat insulation this coefficient will be 0.7387 and 0.912 W/(m<sup>2</sup>·K), respectively, and for a pipeline without insulation 2.11 W/(m<sup>2</sup>·K).

#### 4.2.2. Choking conditions

The dependence of the distance on the pipeline inlet and ambient temperatures for the baseline case study is presented in Fig. 9 and Fig. 10, respectively. It can be seen that the safe pipeline length depends significantly both on the CO<sub>2</sub> pipe inlet temperature (Fig. 9) and the ambient temperature (Fig. 10). In order to avoid the choking condition, recompression of CO<sub>2</sub> becomes necessary.

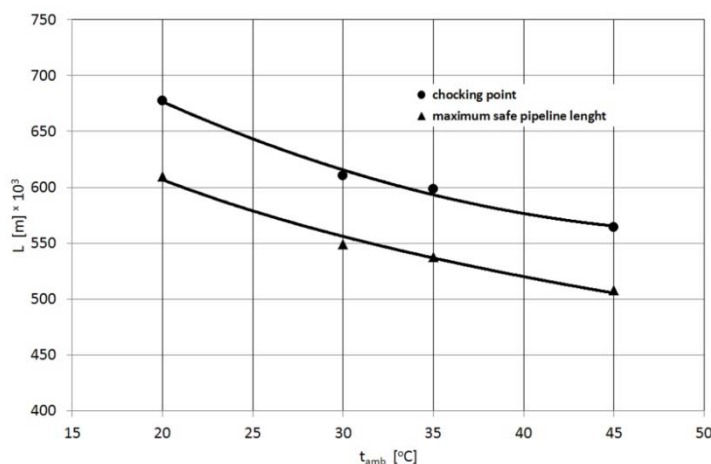

Fig. 9. Differences between a safe flow and the choking point for varying CO<sub>2</sub> pipe inlet temperatures (20 °C, 30 °C, 35 °C, 45 °C) at an energy balance with surroundings

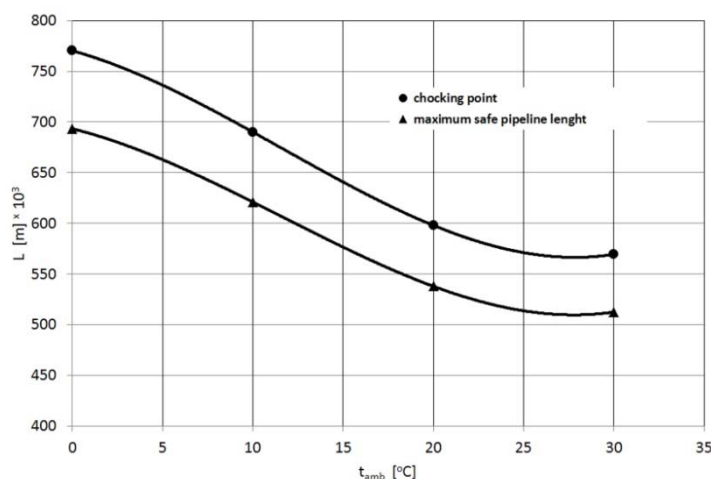

Fig. 10. Differences between a safe flow and the choking point for varying ambient temperatures (0 °C, 10 °C, 20 °C, 30 °C)

#### 4.2.3. Influence of ambient temperature and the thermal insulation layer

In order to understand the impact of thermal insulation, the pipeline operational parameters were calculated with and without an insulation layer with different values of thickness and ambient temperature. Figs. 11 and 12 show changes of the CO<sub>2</sub> pressure, along the pipeline with and without

insulation, at different ambient temperatures calculated with two different real gas equations of state: LKP and PRBM. In the simulation, the inlet conditions for CO<sub>2</sub> are fixed. It is transported to the injection site in a straight line over flat ground. Figs. 11 and 12 reveal that the CO<sub>2</sub> pressure drops linearly along the pipeline. An increase in ambient temperature reduces CO<sub>2</sub> density, increases gas velocity along the pipeline while the pressure drops which leads to building up choking conditions. A bigger pressure drop means higher operating costs and possibly a need to introduce recompression stations. For the purposes of this study, the maximum value of ambient temperature, which in Poland may be as high as 30°C, was assumed. This significantly limits the maximum distance at the inlet pressure of 15.3 MPa to 310 km, compared to the maximum safe distance, which amounts to 403 km at the ambient temperature of 0°C. It can be seen that the maximum difference in the maximum safe transport distance up to the assumed pressure drops to below 9 MPa (about 91 km using the LKP calculations and 78.4 km using the PRBM calculations) is between CO<sub>2</sub> transmission at maximum differences in ambient temperatures and without thermal insulation.

With initial CO<sub>2</sub> temperatures above the supercritical point and calculations made using the LKP equations, CO<sub>2</sub> density changes abruptly within the pipeline once the temperature reaches the saturation point and the two-phase flow commences. It can be seen from Fig. 11 that as ambient temperature gets lower, the safe flow distance is significantly longer because the pressure drop increases significantly with ambient temperature. It confirms the anticipation that low ambient temperature is favourable for pipeline transport. Figs. 13 and 14 show in a clearer way the maximum safe transport distance of the CO<sub>2</sub> pipeline at different ambient temperatures, with and without the thermal insulation layer, respectively. It can be seen that if the inlet temperature keeps constant, the pressure drop gets lower with lower ambient temperatures because gas velocity decreases.

At lower ambient temperatures the pressure drop in the pipeline without thermal insulation is lower than that in an insulated pipeline. It can be seen also from Figs. 13, 14 that the maximum difference in the maximum safe transport distance up to the assumed pressure drops to below 9 MPa (about 32.8 km for both the LKP and PRBM calculations) for two cases with and without insulation is between CO<sub>2</sub> transmission at the ambient temperature of 0°C. However, this difference drops to nearly zero as the ambient temperature increases to about 27°C. Only at the ambient temperature of 30°C is the same transport distance longer for the case with insulation and the LKP equations of state and almost the same at the PRBM equations of state. This confirms the anticipation that a pipeline without thermal insulation is favourable for pipeline transport in the Polish climate. Generally, safe transportation distances calculated with the PRBM equation of state are higher than those calculated with the LKP equation of state.

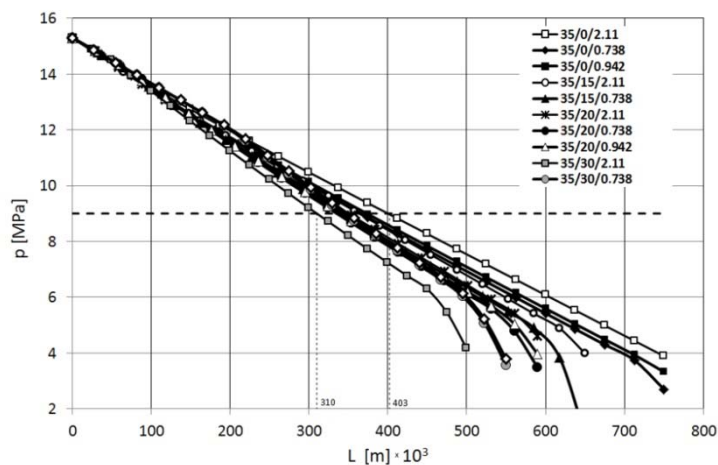

Fig. 11. Comparison of pressure drop along a pipeline with and without thermal insulation for conditions of an energy balance with surroundings at different ambient temperatures: 0 °C, 15 °C, 20 °C, 30 °.

LKP equation of state

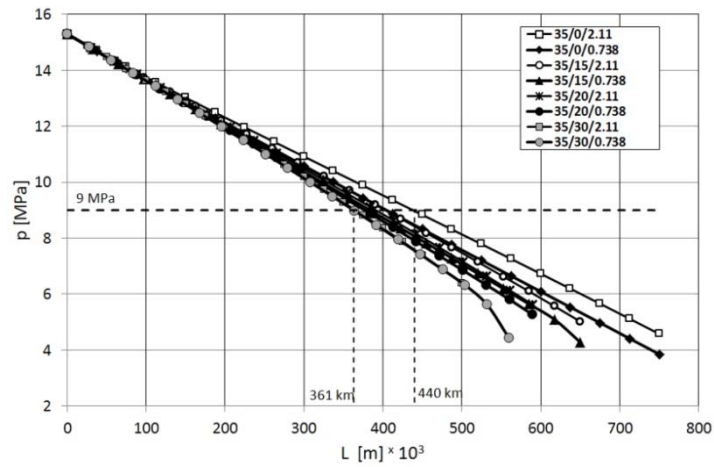

Fig. 12. Comparison of pressure drop along a pipeline with and without thermal insulation for conditions of an energy balance with surroundings at different ambient temperatures: 0°C, 15°C, 20°C, 30°.

PRBM equation of state

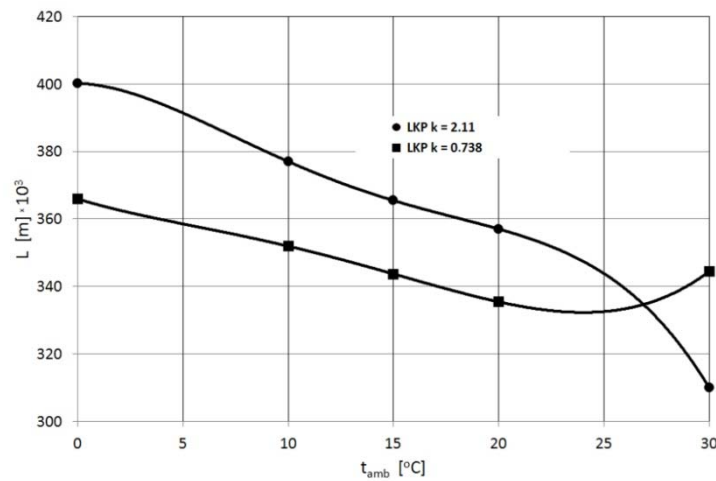

Fig. 13. Maximum safe pipeline length, with and without insulation, to subsequent booster station at different ambient temperatures. LKP equation of state

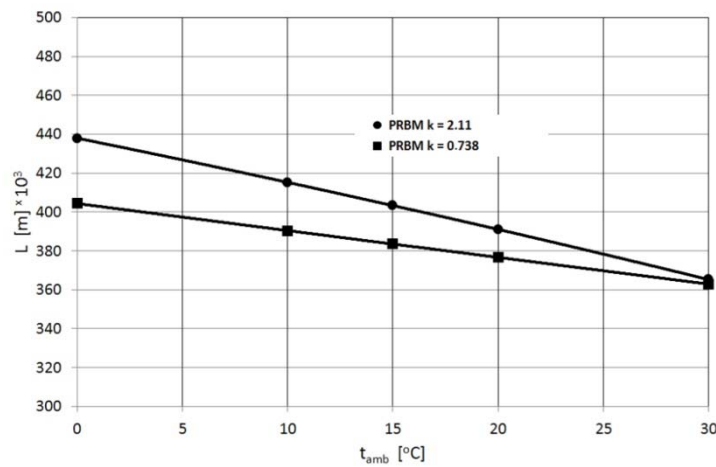

Fig. 14. Maximum safe pipeline length, with and without insulation, to subsequent booster station at different ambient temperatures. PRBM equation of state

### 5. HAZARDS INVOLVED IN CARBON DIOXIDE TRANSPORT

A failure of a pipeline transporting carbon dioxide may lead to a serious leakage. If the released gas concentration reaches a certain level, it will pose a hazard to human health and life. The size of the carbon dioxide cloud released due to the failure will depend primarily on the pipeline geometry and the transported gas parameters (Witlox et al., 2009). Therefore, planning an appropriate route of the pipeline is an essential element of safety management in the pipeline surroundings. A favourable solution is to run the pipeline across uninhabited areas. Otherwise, the pipeline has to be fitted with leak detection systems and safety valves spaced appropriately along its length.

The effect of increased concentrations of carbon dioxide on humans is presented in Table 2 (Det Norske Veritas, 2010).

Table 2. Negative consequences of CO<sub>2</sub> raised concentration for humans

CO <sub>2</sub> concentration in the air [%]	Time of exposure	Consequences for humans
>20	within 1 min	convulsions, coma, death
>10 – 15	1 to several minutes	drowsiness, loss of consciousness
6	≤ 16 minutes	headache, breathing problems
4 – 5	within several minutes	headache, rise in blood pressure, breathing discomfort
3	1 hour	sweating, breathing problems while resting
0.5 - 1	8 hours	acceptable occupational risk level

As can be seen, a higher concentration of the gas may present serious hazard to human health and life. For this reason, a need arises to estimate the consequences of a potential failure as early as at the design stage. For instance, for the pipeline and the gas parameters analysed in this work ( $d = 0.45$  m,  $p = 153$  bar,  $t = 20$  °C) the area with the highest, hazardous to humans, concentration of 20% extends over approximately 720 m<sup>2</sup> and its range is 115 meters. The area with a 10% concentration will extend over approximately 3750 m<sup>2</sup> with the range of 244 meters.

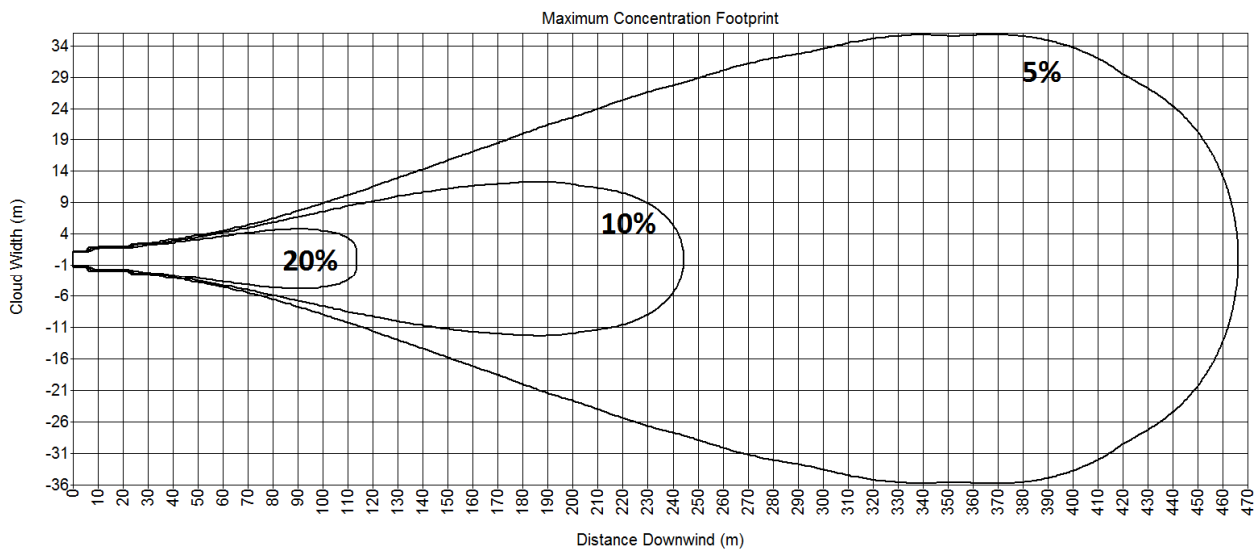

Fig. 15. Example of CO<sub>2</sub> concentration areas for a 50 km long pipeline

For a 5 % concentration, the zone covers the area of about 20,000 m<sup>2</sup> with the range of about 465 meters (Fig. 15). The presented results were obtained using the PHAST v6.7 software package (PHAST, 2010).

The calculated values of gas concentration in the damaged pipeline area will allow a further estimation of the risk. Quantitatively, risk is understood as the product of the probability of the occurrence of a hazardous event and its consequences. Denoting the risk as  $R$ , the following can be written:

$$R = \sum_i P_i C_i \quad (1)$$

In the case of carbon dioxide pipeline transportation, the probability of the occurrence of a hazardous event in the form of a gas release from a pipeline can be determined using the event tree method. The event tree is shown in detail in Fig. 16.

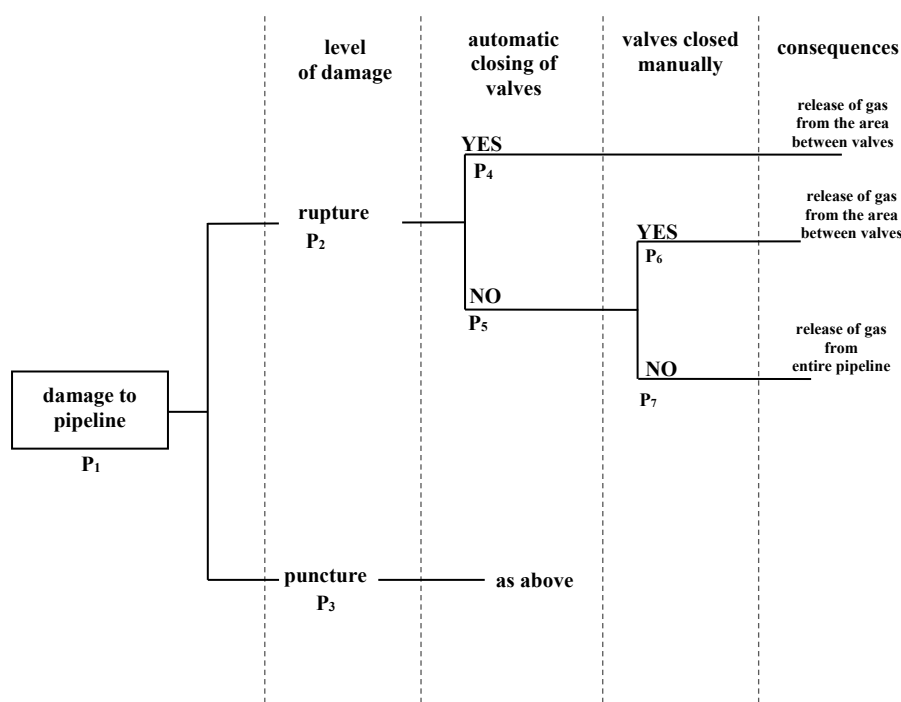

Fig. 16. An event tree for a carbon dioxide transport pipeline failure

In the event tree presented above as the initial event a damage to pipeline transporting carbon dioxide was assumed. Next, the extent of the pipeline damage is determined. One distinguished possibility is the pipeline total damage, i.e. the gas is released through a hole with a diameter equal to that of the pipeline diameter. The probability of such a situation is estimated at 10% of all pipeline failure cases. Another possibility is a partial damage to the pipeline. In this case, the gas leak occurs through a hole with a diameter equal to several per cent of the pipeline diameter. It is estimated that such failures constitute approximately 90% of the overall number. The next stages presented in the event tree are related to safety valves closing. This can be done automatically or manually. The final effects of damage to the pipeline come down to two basic situations: the gas is released from the entire pipeline or from a pipeline section cut off by two neighbouring safety valves. Assuming the following probability values:  $P_1=2 \cdot 10^{-5}$  [1/year/km],  $P_2=0.1$ ,  $P_3=0.9$ ,  $P_4=0.99$ ,  $P_5=0.01$ ,  $P_6=0.9$  and  $P_7=0.1$ , the probability of an uncontrolled release of CO<sub>2</sub> can be calculated (Koornneef et al., 2010).

A probit function, i.e. a function that relates the harmful factor dose size to the dose impact on human health and life, is used to estimate the consequences of a potential failure. In the case of carbon dioxide, the consequence is death due to the gas raised concentration. The probit function may thus be expressed as (McGillivray, 2009):



$$P_r = -90.80 + 1.01 \ln(C^8 \tau) \quad (2)$$

The probability of the pipeline failure calculated based on the event tree analysis and the consequences of exposure to a higher concentration of CO<sub>2</sub> can be used to estimate what is referred to as individual risk, i.e. the risk posed to an individual who finds him/herself in the hazardous area. The individual risk can be defined as:

$$R = P \cdot P_r \quad (3)$$

Figure 17 presents areas with the individual risk level of  $5 \cdot 10^{-4}$  if safety valves for cutting off the damaged sections of the pipeline are spaced at a distance of 50 km and 5 km.

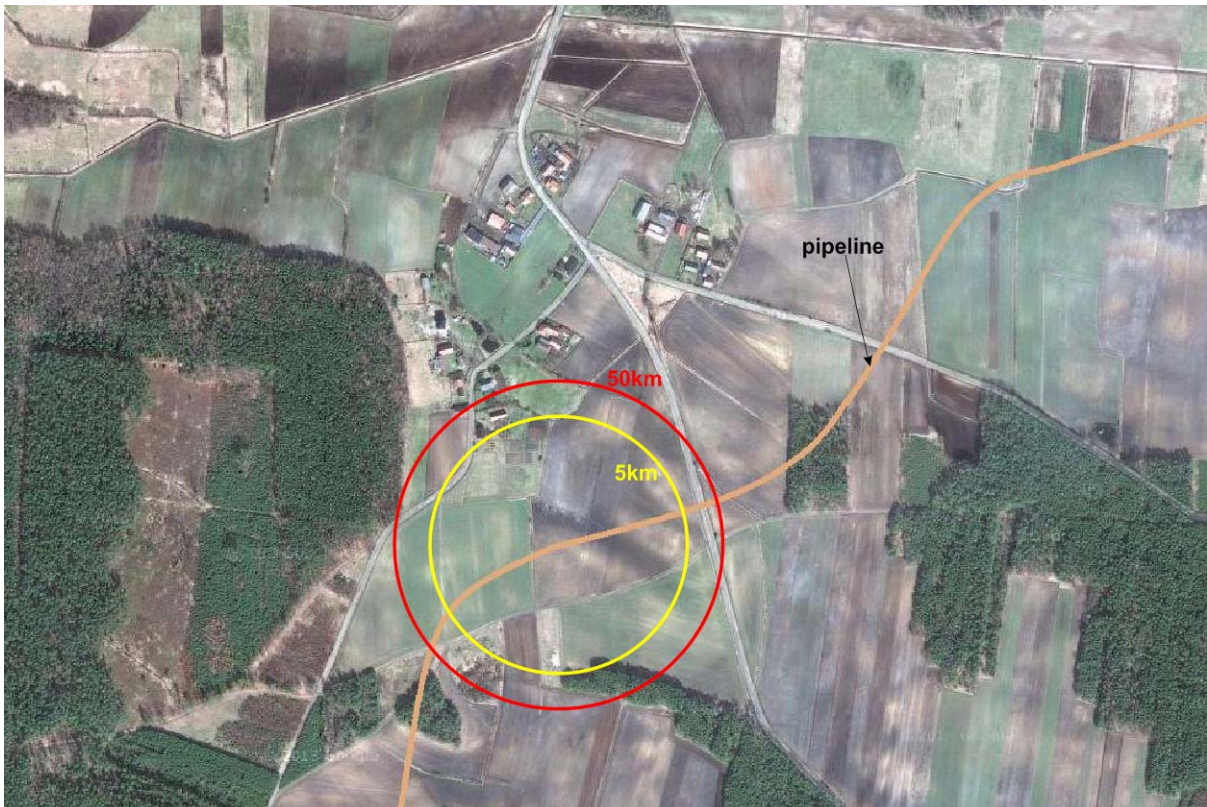

Fig. 17. Areas of risk level of  $5 \cdot 10^{-4}$

If safety valves are used in an inhabited zone, the risk area is diminished from about 119,000 m<sup>2</sup> to approximately 80,000 m<sup>2</sup> surrounding the failure location.

## 6. CONCLUSION

Three different feasible strategies for compressing CO<sub>2</sub> in a coal-fired power plant with post-combustion CO<sub>2</sub> capture were studied. Their performance was quantified and compared with that of a conventional centrifugal compression solution.

This study emphasises the fact that the total compression power is a strong function of the thermodynamic process and is not determined by the compressor efficiency only.

The results of this study show that compression power savings of almost 15% compared to the conventional process using integrally geared compressors can be obtained.

The compression power savings of almost 21.95% can be achieved if CO<sub>2</sub> is first compressed to an intermediate pressure of 80 bar, then cooled and liquefied and the liquid is then pumped to the final pressure required for pipeline injection.

Liquefaction and pumping equipment will entail additional capital expenses, but some of them will be offset by the lower cost of pumps, compared to high-pressure compressors.

This paper presents also an analysis of the influence of multiple factors, including the pipeline inlet temperature, ambient temperature, ground level heat flux conditions and the thermal insulation layer, on the thermodynamic performance of the CO<sub>2</sub> flow in the pipeline and proposes a common rule for designing CO<sub>2</sub> transport pipelines with a view to minimising the pressure drop. It takes account of issues such as lacking thermal insulation layer in the Polish atmospheric conditions and lowering the transport temperature.

To sum up, when designing a pipeline, the extreme case with the highest ambient temperature should be considered to ensure that the pipeline can work well all throughout the whole year. For a CO<sub>2</sub> stream in the inlet supercritical state (35°C), the maximum safe transmission distance is 310 km.

The calculations were performed assuming pure carbon dioxide. However, captured CO<sub>2</sub> will include a series of impurities depending on the capture technology, which has an effect on the CO<sub>2</sub> phase diagram. Even small amounts of impurities in CO<sub>2</sub> change the location of the saturation line. Therefore larger safety margins may have to be used in CO<sub>2</sub> pipeline design.

Due to the fact that high concentrations of CO<sub>2</sub> resulting from an uncontrolled leak pose a serious hazard to human health and life, special safety precautions, such as safety valves, have to be installed on pipelines. The results of the analysis indicate that appropriate spacing of the valves may keep the risk factor the acceptable level.

*The results presented in this paper were obtained from research work co-financed by the National Centre of Research and Development in the framework of Contract SP/E/1/67484/10, Strategic Research Programme (Advanced Technologies for Energy Generation: Development of a Technology for Highly Efficient Zero-Emission Coal-Fired Power Units Integrated with CO<sub>2</sub> Capture).*

## SYMBOLS

$C$	concentration, in equation (2), ppm
$C_i$	consequences of occurrence of event $i$
$d$	diameter, m
$L$	length, m
$\dot{m}$	flow, kg/s
$N$	power, kW
$p$	pressure, bar
$P$	probability of occurrence of a hazardous event
$P_i$	probability or frequency of occurrence of a hazardous event $i$
$P_r$	probit function, i.e. the value of probability of a fatal injury to the body
$S$	specific entropy, kJ/kg·K
$t$	temperature, °C

### *Greek symbols*

$\Delta p$	pressure loss, bar
$\eta$	efficiency



$\Pi$	pressure ratio
$\tau$	time of exposure to the gas raised concentration, s

#### Subscripts

$p$	polytropic
$c$	critical
max	maximum
amb	ambient

#### Abbreviations

PRBM	Peng-Robinson Boston-Mathias equation of state
LKP	Lee-Kesler Plocker equation of state

## REFERENCES

- Antoniades C., Christofides P.D., 2001. Studies on nonlinear dynamics and control of a tubular reactor with recycle. *Nonlinear Analysis - Theory Methods and Applications*, 47, 5933-5944. PII: S0362-546X(01)00699-X.
- Aspen Plus, Version 7.0, 2008, *User Guide*.
- Botero C., Finkenrath M., Belloni C., Bertolo S., D'Ercole M., Gori E., Tacconelli R., 2009. Thermoeconomic evaluation of CO<sub>2</sub> compression strategies for post-combustion CO<sub>2</sub> capture application. *Proc. ASME Turbo Expo 2009: Power for Land, Sea, and Air*, 517-526. DOI: 10.1115/GT2009-60217.
- Bovon P.R., Habel R., 2007. CO<sub>2</sub> compression challengers. *ASME Turbo Expo*. Montreal. 15 May 2007.
- Det Norske Veritas, 2010. *Design and operation of CO<sub>2</sub> pipelines. Recommended practice, DNV-RP-J202*. DNV, Veritasveien, Høvik, Norway.
- Incropera F.P., DeWitt D.P., 1996. *Introduction to heat transfer*. 3rd edition, John Wiley & Sons, Inc., New York.
- Koopman A.A., Bahr D.A., 2010. The impact of CO<sub>2</sub> compressor characteristics and integration in post-combustion carbon sequestration. Comparative economic analysis. *Proc. ASME Turbo Expo 2010: Power for Land, Sea, and Air*. Glasgow, UK, 14-18 June 2010, 601-608. DOI: 10.1115/GT2010-22974.
- Koornneef J., Spruijt M., Molag M., Ramirez A., Turkenburg W., Faaij, A., 2010. Quantitative risk assessment of CO<sub>2</sub> transport by pipelines – A review of uncertainties and their impacts. *J. Hazard. Mater.*, 177, 12-27. DOI: 10.1016/j.jhazmat.2009.11.068.
- Lüdtke H., 2004. *Process Centrifugal Compressors*. Springer Berlin Heidelberg. DOI: 10.1007/978-3-662-09449-5.
- Lukowicz H., Dykas S., Rulik S., Stępczyńska K., 2010. Thermodynamic and economic analysis of a 900 MW ultra-supercritical power unit. *Arch. Thermodyn.*, 32, 231-244. DOI: 10.2478/v10173-011-0025-1.
- McCoy S.T., Rubin E. S., 2008. An engineering-economic model of pipeline transport of CO<sub>2</sub> with application to carbon capture and storage. *Int. J. Greenhouse Gas Control*, 2, 219-229. DOI: 10.1016/S1750-5836(07)00119-3.
- McGillivray A., Wilday J., 2009. *Comparison of risks from carbon dioxide and natural gas pipelines*, HSE report rr749, available at: [www.hse.gov.uk/research/rrpdf/rr749.pdf](http://www.hse.gov.uk/research/rrpdf/rr749.pdf).
- Mohitpour M., Seevam P., Botros K.K., Rothwell B., Ennis C., 2012. *Pipeline transportation of carbon dioxide containing impurities*. ASME Press, New York.
- Moore J.J., Nored M.G., 2008. Novel concepts for the compression of large volumes of carbon dioxide, *Proc. ASME Turbo Expo 2008: Power for Land, Sea, and Air*. Berlin, Germany, 9-13 June 2008, 645-653. DOI: 10.1115/GT2008-50924.
- PHAST v.6.7, DNV Software, 2010.
- Wolk R.H., 2009. *Proceedings of the workshop on future large CO<sub>2</sub> compression systems*. Gaithersburg, 30-31 March 2009, available at: [http://www.nist.gov/pml/high\\_megawatt/upload/March-2009-CO2-Workshop-Proceedings.pdf](http://www.nist.gov/pml/high_megawatt/upload/March-2009-CO2-Workshop-Proceedings.pdf).
- Witkowski A., Rusin A., Majkut M., Rulik S., Stolecka K., 2013. Comprehensive analyses of the pipeline transportation systems for CO<sub>2</sub> sequestration. Thermodynamics and safety problems. *Energy Convers. Manage.*, 76, 665-673. DOI: 10.1016/j.enconman.2013.07.087.
- Witlox H.W.M., Harper M., Oke A., 2009. Modelling of discharge and atmospheric dispersion for carbon dioxide releases. *J. Loss Prev. Process Ind.*, 22, 95-802. DOI: 10.1016/j.egypro.2011.02.114.

Zhang D., Wang Z., Sun J., Zhang L., Zheng L., 2012. Economic evaluation of CO<sub>2</sub> pipeline transport in China. *Energy Convers. Manage.*, 55, 127-135. DOI: 10.1016/j.enconman.2011.10.022.

Zhang Z.X., Wang G.X. Massarotto, P., Rudolph V., 2006. Optimization of pipeline transport for CO<sub>2</sub> sequestration. *Energy Convers. Manage.*, 47, 702-715. DOI: 10.1016/j.enconman.2005.06.001.

*Received 04 April 2014*

*Received in revised form 16 October 2014*

*Accepted 17 October 2014*