

Castings in Pit Furnaces for Heat Treatment

A. Drotlew, B. Piekarski*

West Pomeranian University of Technology,
Al. Piastów 17, 70-310 Szczecin, Poland

*Corresponding author. E-mail address: bogdan.piekarski@zut.edu.pl

Received 25.02.2015; accepted in revised form 20.07.2015

Abstract

The article presents examples of typical designs of the cast technological equipment used in pit furnaces for the heat treatment of metals and alloys. The equipment consists of a set of castings connected together in a proper way and used for the formation and transport of charge, which consists of the heat treated parts. Typical equipment has the shape of a cylinder. Usually it comprises a basic pallet (carrier) completed with other elements, i.e. intermediate pallets, rods, spacers, cross-bars and hooks, their number depending on the number and shape of heat-treated products and on production volume. The simplest design solution is to use a cylindrical basket where heat treated products are arranged in a loose configuration. The majority of elements forming the furnace equipment are castings produced in sand molds. Some of them were designed and manufactured in a Foundry of the West Pomeranian University of Technology in Szczecin.

Keywords: Innovative foundry technologies and materials, Castings for heat treatment plants, Grates

1. Introduction

Common use of furnaces for heat treatment in all sectors of the industry is the reason why their construction is the subject of constant interest to designers. The aim of this work is to improve their efficiency and reliability.

One of the stages in the design process of furnaces is the design of their technological equipment. This equipment is a complex set of elements, allowing for the charge formation (parts heat treated) inside the furnace and transport of this charge both inside and outside the furnace. Conferring to the equipment the required durability and reliability for the longest possible service life requires from the designer careful analysis of many factors associated with the production and operation of this equipment [1–9].

The durability and reliability of furnace equipment is generally higher when respective elements are made by the technique of casting. However, the decision which manufacturing method should be adopted results from the complex analysis taking into account the total cost of execution, shape and size, life

expectancy, the required number of pieces in a lot and the mechanical properties of material. Therefore, equipment manufactured by processes other than casting is also used [3, 4].

Cast components of the furnace equipment are mainly made from:

- cast steel of the GX40CrNiSi25-20 (1.4848), GX40NiCrSi38-19 (1.4865) or GX40NiCrSiNb38-19 (1.4849) grade, when the temperature in the working chamber of the furnace is up to 1050°C;
- cast nickel alloys (e.g. G-NiCr28W – 2.4879), when the heat treatment temperature is in the range of (1000–1150)°C [1–5].

In this article, some typical design solutions for the furnace equipment based on a cylindrical shape and composed of cast elements have been presented. This type of structure is mainly used in pit furnaces with controlled atmosphere.

2. Design of the equipment

The simplest solution is to use the equipment in the form of a cylindrical basket (Fig. 1). The basket consists of two parts: a housing (Fig. 1-1) and an inserted bottom (Fig. 1-2). The basket design also allows placing baskets on one another, depending on the size of the furnace working chamber. Parts for the heat treatment are loaded into the basket as loose elements.

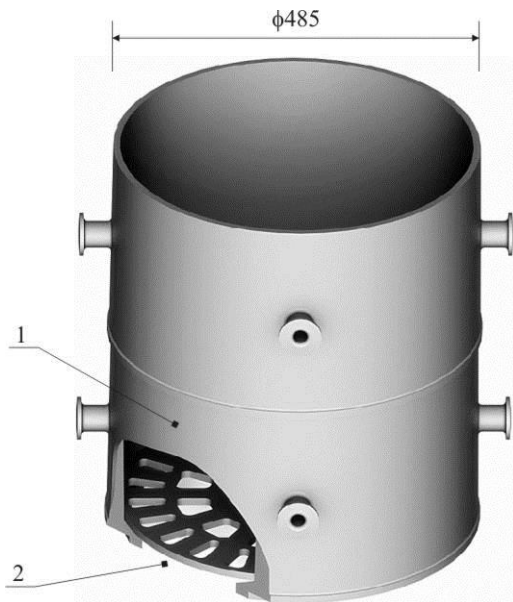

Fig. 1. The cast baskets used in pit furnaces:
1 – housing, 2 – bottom

The shape of the pit furnace working chamber is particularly suitable for the heat treatment of long and slender objects. In such cases, the equipment is of simple design. It consists of (Fig. 2):

- pallet on which the heat-treated parts are suspended;
- rod attached to the pallet and ending at the other end in a transport hook.



Fig. 2. Simple equipment used in a pit furnace for the heat treatment of long objects

Single basic pallets are also used for the heat treatment of massive parts. Parts to be heat-treated are placed on these pallets using suitably designed supporting components (Fig. 3a). In this case, the total weight of the equipment is 560 kg, and it comprises a total of 27 cast components (Fig. 3b).

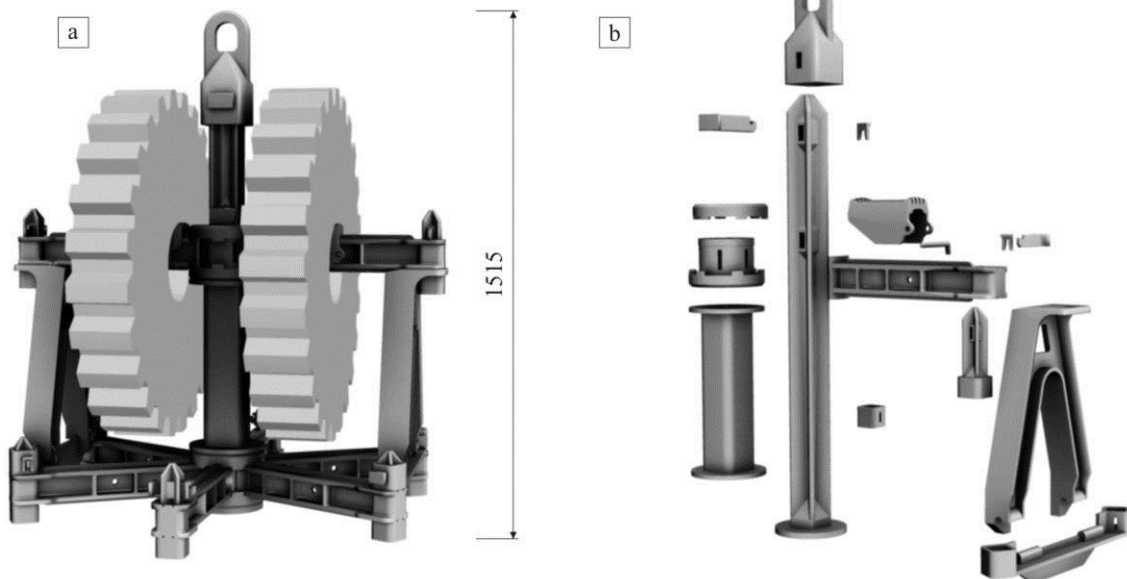

Fig. 3. Technological equipment made of cast components used for the heat treatment of large gears:
a) general view [3], b) individual components of the equipment

Various component assemblies used for the charge arrangement and transport in pit furnaces often include cross-shaped elements (Fig. 4a). Between their arms are stacked small pallets, forming a round basis on which the heat treated parts are placed.

Equipment of this type consists of cross-bars, small intermediate pallets, spacers and positioning rods ended in transport hooks (Fig. 4b).

The equipment most commonly used in pit furnaces consists of pallets and external positioning rods (Fig. 5). The number of pallets used depends on the shape and dimensions of the heat-treated parts and also on the arrangement of those parts. The distance between the pallets is determined by the length of the spacers. Free spaces between the pallets can be filled with hangers. This makes the distribution of the heat-treated parts easier and results in a well-balanced flow of the furnace atmosphere.

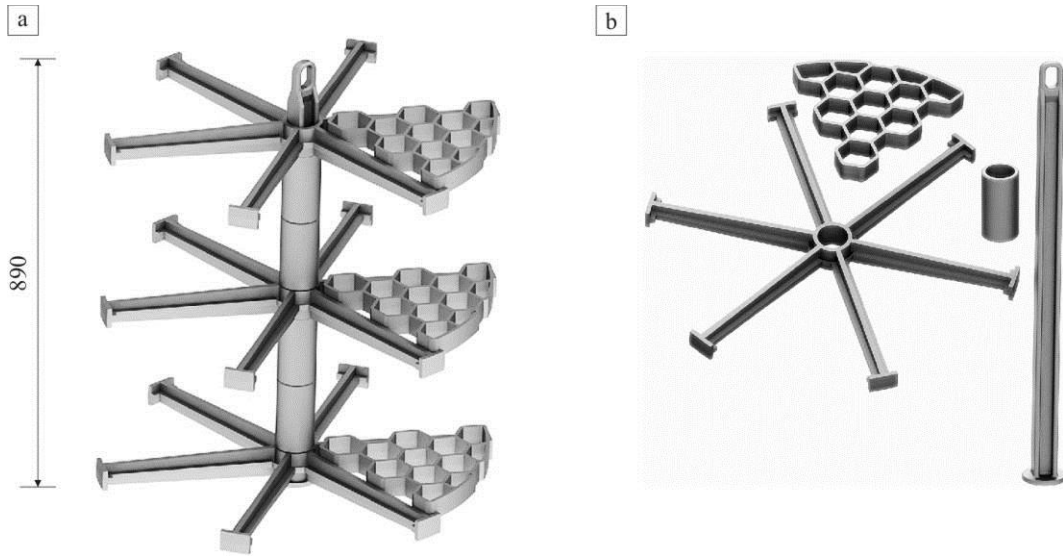

Fig. 4. Technological equipment with cross-shaped elements used in pit furnaces: a) general view, b) individual components of the equipment

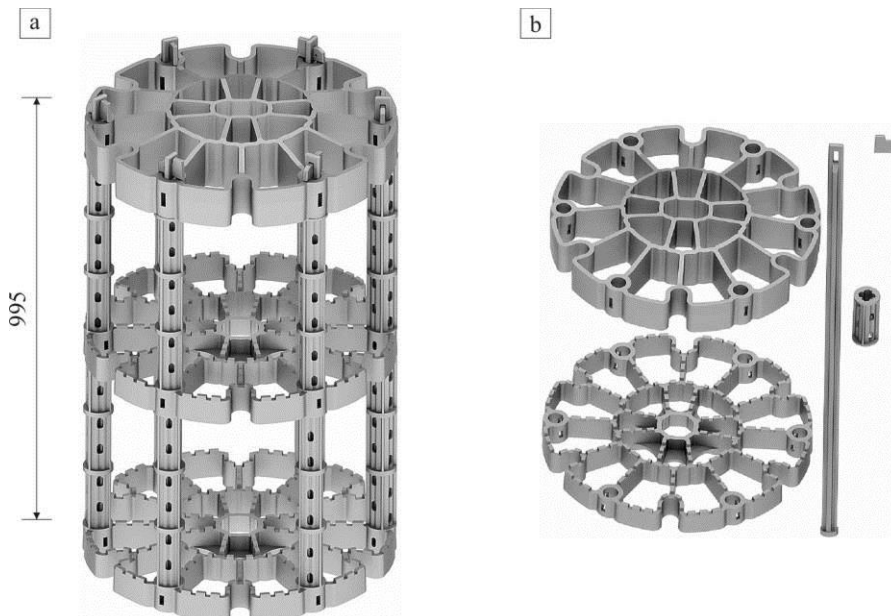

Fig. 5. Technological equipment with round pallets used in pit furnaces: a) general view, b) individual components of the equipment

When the heat-treated parts are of large overall dimensions making their loading and unloading difficult or even impossible without the need for assembly / disassembly of the positioning rods (Fig. 6a), a different way of assembly / disassembly of the equipment can be applied. This requires, however, changes in the method of attachment of the positioning rods to pallets (Fig. 6b).

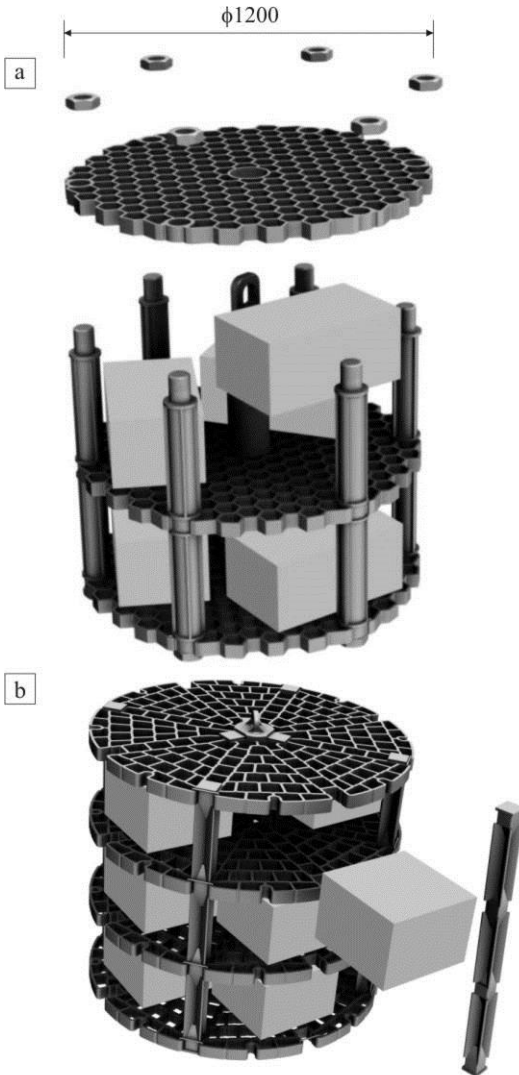

Fig. 6. Technological equipment for a pit furnace [3]:
a) conventional solution, b) modified method of assembly /
disassembly of the positioning rods

3. Final remarks

The outlined design solutions for the technological equipment used in pit furnaces are the result of detailed analysis of the impact and effect of various structural factors determining the durability of this equipment. Among these factors are the operating conditions (a wide range of changes in the operating

temperature) and the expected type of charge (size, shape and weight of the heat-treated parts).

Regardless of the analysis made, the design engineer of the equipment must remember that the equipment should have as low weight as possible, since the weight of the equipment has a direct impact on productivity and run of the heat treatment process [6–9]. In practice, the weight of the equipment can reach even 50 to 100% of the charge weight.

The designer, in order to properly design the equipment, should have thorough knowledge and skills regarding [4]:

- all issues related to the strength of a structure undergoing the process of thermal fatigue and to the durability of materials of which this structure, operating under specific technological conditions, has been made;
- behavior of the structure when loaded with charge during operation.

The equipment (Figs. 2, 3, 5 and 6) was designed by the authors of this article. Nearly all of the proposed design solutions have already been used in industrial practice, in part or in whole. Therefore they are subject to protection of intellectual property resulting, among others, from the Act of 4 February 1994 on Copyright and Related Rights, the Act of 30 June 2000 on Industrial Property Law, and the Law of 16 April 1993 on unfair competition.

References

- [1] Lai, G.Y. (2007). *High-Temperature Corrosion and Materials Applications*. ASM International.
- [2] Steinkusch, W. (1985). Verbesserte Werkstoff und Konstruktionen verringern Betriebskosten bei der Wärmebehandlung. *Fachberichte Hütten. Metall.* 23, 746-749.
- [3] Piekarski B. (2012). *Creep-resistant castings used in heat treatment furnaces*. Wydawnictwo Zachodniopomorskiego Uniwersytetu Technologicznego w Szczecinie, Szczecin (in Polish).
- [4] Lai, G.Y. (1991). Heat-Resistant Materials for Furnace Parts, Trays, and Fixtures. In *ASM Handbook 4 – Heat Treating* (510-518). ASM International.
- [5] Davis, J.R. (Ed.). (1997). Industrial Applications of Heat-Resistant Materials. In *Heat Resistant Materials* (67-85). ASM International.
- [6] Drotlew, A., Garbiak, M., Kubicki, J., Piekarski, B., Siluk, P. (2013). Structure of guide grate in heat treatment technological equipment. *Prace Instytutu Odlewnictwa* 3, 59-71 (in Polish).
- [7] Piekarski, B. & Drotlew, A. (2010). Cast functional accessories for heat treatment furnaces. *Archives of Foundry Engineering*. 4, 183-190.
- [8] Drotlew, A., Garbiak, M. & Piekarski, B. (2013). Technological equipment for heat treatment. *Mechanik* 5-6, 398-403 (in Polish).
- [9] Drotlew, A., Garbiak, M. & Piekarski, B. (2014). Chamber furnace technological equipment assembled from cast components. *Przegląd Odlewnictwa* 7-8, 264-268 (in Polish).