

MACIEJ JAN KUPCZYK*, JĘDRZEJ KOMOLKA**,

COMPARATIVE STUDY OF TECHNOLOGICAL AND FUNCTIONAL PROPERTIES OF CUTTING EDGES MADE OF CONVENTIONAL AND SINTERED HIGH SPEED STEEL

In the article selected fragments of investigations of technological properties of cutting edges made of conventional and sintered high speed steel with similar chemical composition are presented. Investigations of technological properties have comparative character and concern among other things estimation of chemical composition, hardness, structure and durability during toughening steel machining. At the end of article conclusions are presented.

Keywords: conventional and sintered high speed steel, properties

1. INTRODUCTION

Despite the rapid developments in materials used for cutting edges, high speed steel all the time maintains usefulness in applications with moderate cutting speeds due to significant bending and torsional strength in comparison to other tool materials. Significant influence on the cutting ability of tools made of high speed steel has its structure. The most important components in the structure of high speed steels are the carbide phases, which dispersion and distribution have major influence on the final characteristics of steel as well as its anisotropy. Reviewing existing articles about possibility of modifying the properties of high speed steel via sintering, authors note that many professional publications are mainly about comparison of technological characteristics, as a chemical composition, microscope photographs with particular emphasis on carbide phases distribution and similitude particle size, degree of isotropy, hardness, bend strength and impact resistance. There are also articles taking into account functional characteristics, but not encountered on area of applicability that is machining quality steel with different cutting speed with and without lubricating and cooling liquid [8,12, 13, 15].

The final aim of the study (after carrying out the performance test) is to ascertain whether powder metallurgy is the appropriate course for improving the characteristics of cutting edges made of high speed steels, as high speed steels manufactured in conventional processes seem to have reached the limit of their functional characteristics.

* prof. dr hab. inż. - Poznan University of Technology, Institute of Mechanical Technology

** mgr inż. - Poznan University of Technology, Institute Mechanical Technology, Piotrowo 3

2. MATERIAL USED IN THE STUDY

2.1. Description of the cutting edge material

The material was selected and prepared for two types of multi-blade cutting inserts from conventional HS6-5-2 and sintered PM6-5-2 high speed steel. The selection is justified by the common use of this grade of steel, which used to be referred to by the designation SW7M.

Table 1 shows the approximate chemical composition of the conventional and sintered variant of the steel.

Table 1
Approximate chemical analysis of both conventional (HS6-5-2) and sintered (PM6-5-2) HS steels

Item	Chemical composition [%]					
	C	W	Mo	V	Cr	Mn
Conventional steel	0.8-0.84	5.9-6.7	4.7-5.2	1.7-2.0	4.2	0.4
Sintered steel	1.0	6.0	5.0	2.0	4.5	0.3

Cutting inserts made of sintered high speed steel were made of commercial semi-finished flat bars. The cutting inserts made of conventional steel were obtained from metallurgical products in the form of billets. On delivery, both types of steel used in the study were in the softened condition. Figure 1a shows the semi-finished product to be used for the plates.

The next step was the grinding of the conventional high speed steel billets and sintered high speed steel flat bars to achieve the specified thickness on the flat-surface grinding machine and their cutting into cutting inserts using a wire EDM by Agiecut Classic 2 model.

The aforementioned high speed steel materials were used to fashion rectangular SNUN type cutting inserts with angle 90°. This insert geometry is used for milling high temperature creep resistant alloys, stainless steels, alloy steels and soft steels with low carbon content. The dimensions and shape of the cut inserts are shown in Table 2 and in Fig. 1b and [11].

Table 2
Size of cutting edges used during the study

$L = d$ [mm]	s [mm]	r_e [mm]	m [mm]
9.525	3.18	0.8	1.644

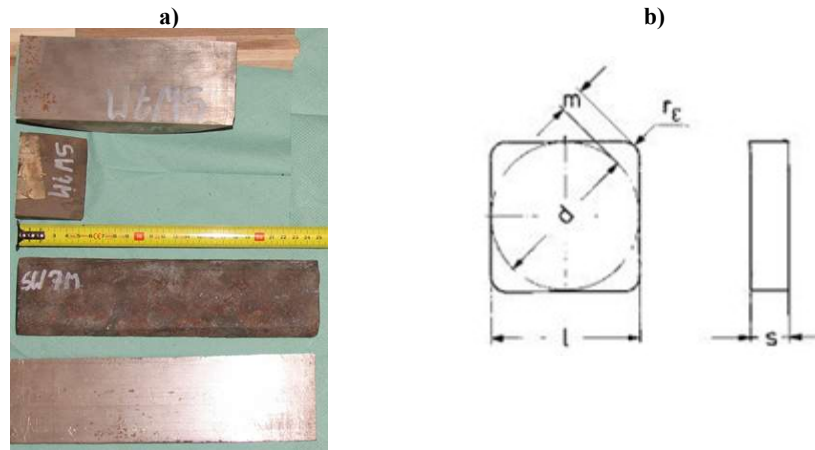

Fig. 1. a) Metallurgical semi-finished products for cutting edges manufacturing, b) form of cutting edges used in the study

The insert cutting edges were clamped in the hR 110.16-220 holder. The cutting edge clamped in the holder has the following geometry:

- tool cutting edge angle $\kappa_r = 75^\circ$,
- tool orthogonal clearance $\alpha_0 = 6^\circ$,
- tool included angle $\varepsilon_r = 90^\circ$,
- tool orthogonal rake angle $\gamma_0 = -6^\circ$,
- tool cutting edge inclination $\lambda_s = -6^\circ$.

The expected properties for the SW7M steel (HS6-5-2, PM6-5-2) are achieved after thermal processing which involves quenching and tempering. To achieve high hardness of approx. 65 HRC, the assumed temperature of austenitization temperature is 1150°C, and the temperature of tempering is 560°C. The aforementioned values allow the edge to be momentarily heated up to 500°C during the milling process without the risk of substantial softening by the heat generated during the milling. Properly selected temperature of tempering allows to achieve secondary hardening. Such cutting edges retain working ability at elevated temperatures, close to temperature of tempering of the cutting edge [1, 4, 6, 9].

Due to the low heat conductivity, the material was heated gradually. The entire process was carried out in vacuum due to the risk of decarburization and oxidation. Fig. 2 shows the course of thermal processing. To this end, a SECO/WARWICK type 6.0VPT-4022/24IQHV vacuum furnace, with high vacuum system, manufactured in Poland, was used.

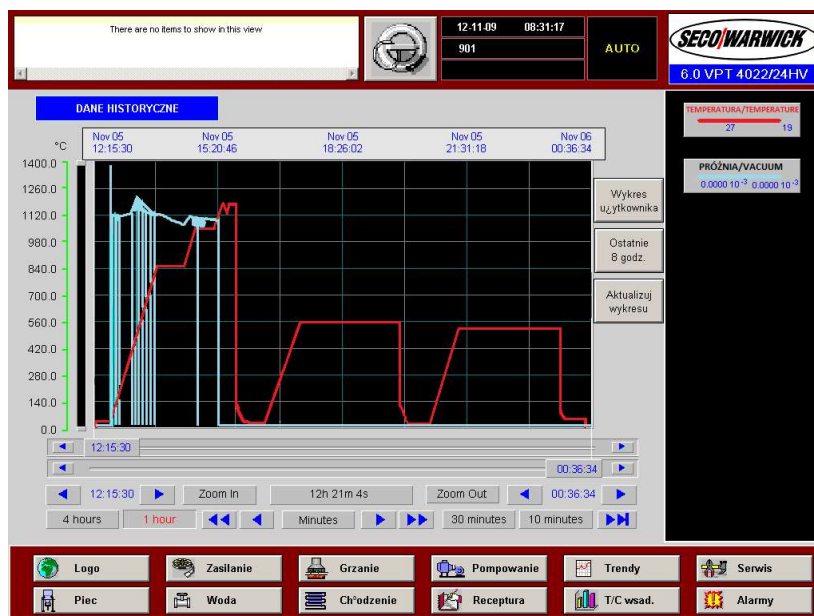

Fig. 2. Run of heat treatment of cutting edges made of HSS in SECO/WARWICK type 6.0VPT-4022/24IQHV vacuum furnace (own source)

2.2. Characteristics of the workpiece material

The workpiece material used in the study made of the 40HM-T toughening steel in the shape of shafts have a diameter of ϕ 110 mm, a length of 350 mm and hardness of 30 HRC. This steel grade is used for components requiring high reliability, durability and ductility. The yield strength for this material is 880 MPa, and the tensile strength is 1030 MPa. Table 3 shows the chemical composition of the 40HM-T steel [5].

Table 3
Approximate of chemical analysis of the 40HM-T steel (according to PN-EN ISO 4597)

Chemical composition [%]									
C	Mn	Si	P,S	Cr	Ni	Mo	W	V	Cu
0.38-0.45	0.4-0.7	0.17-0.37	<0.035	0.8-1.2	<0.3	0.15-0.25	<0.2	<0.05	<0.25

3. STUDY OF TECHNOLOGICAL PROPERTIES

For the Vickers hardness test, a PICODENTOR HM500 hardness tester manufactured by Fischer was used. Hardness was measured at penetrator load of 30 kG for 20 s in accordance with the applicable standard. One of the conditions for accurate hardness measurement was to treat the surface of the tested material so that its roughness is at least 10 times less than the depth of penetration. To this end, the insert surface was polished. In the polishing process, the inserts were degreased.

For the hardness test, 3 indentations were performed for each insert, bearing in mind that the spacing should be equal to at least 3 times the diagonal of the impression. As it results from the measurements, the hardness of sintered steel cutting edges is about 5% higher, amounting to 1030.5 HV30 on average for sintered steel, and 982.3 HV30 for conventional steel respectively, which conforms to the data obtained by Sandvick [11].

The actual chemical composition of cutting edges was established by means of the x-ray fluorescence spectrometer – Fischerscope X-ray XDV-SDD Fisher. The exemplary results of these tests are presented in Fig. 3 and 4.

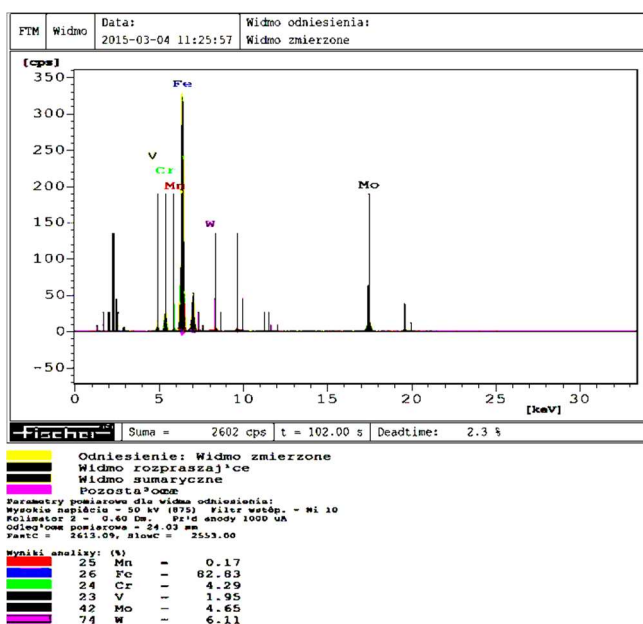

Fig. 3. Exemplary image of chemical microanalysis of edges made of the HS6-5-2 conventional steel

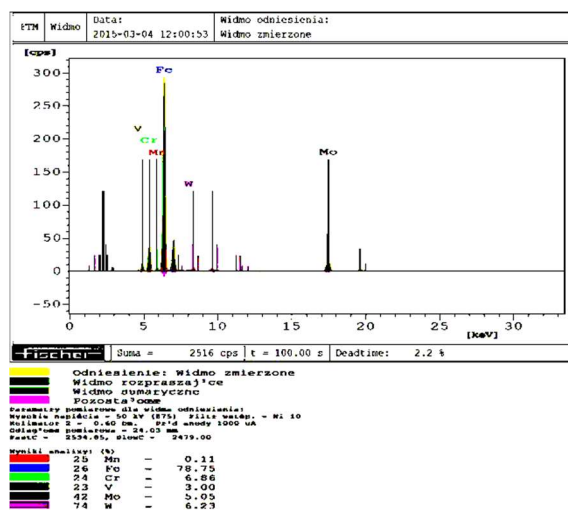

Fig. 4. Exemplary image of chemical microanalysis of edges made of the PM6-5-2 sintered steel

For conventional and sintered high speed steels, 8 measurements of chemical composition were carried out. The average values with regards to the content of alloy elements did not vary significantly from the values given in Table 1, which was confirmed by means of calculations of significance of differences of average assumed and measured values for significance level $\alpha = 0.05$ and number of degrees of freedom 7. A series of photographs of the surface of conventional and sintered high speed steel edges were taken using the Tescan Vega 5135 scanning microscope (Fig. 5).

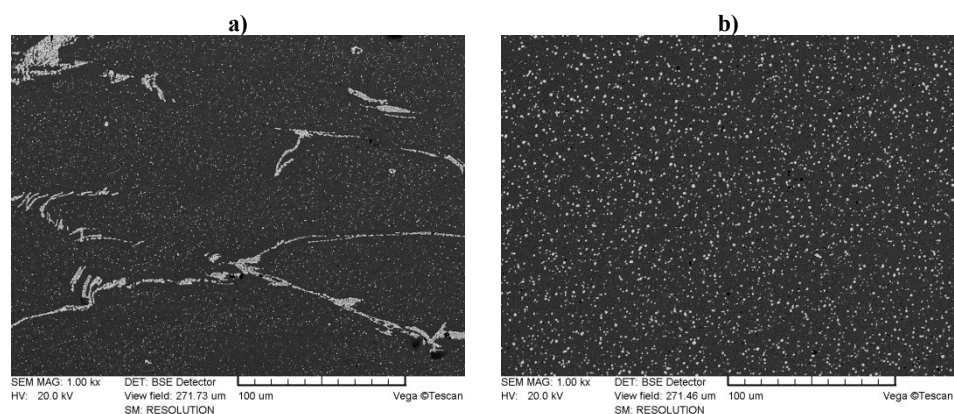

Fig. 5. Microscope images of edges made of: a) conventional, b) sintered high speed steels

The microscope images confirmed a more even distribution of carbides in the chain in the case of sintered steel.

With regards to the conventional high speed steel, it is observed that the carbides are not distributed uniformly and form band-shaped clusters, which is typical for high speed steels subject to rolling, stretch forging, or stretch forging with indirect upsetting.

3.1. Results of functional properties

The tests of wear and durability of cutting edges were performed during the process of straight turning.

The following conditions were assumed for the processing:

- turned material 40 HM-T steel,
- cutting speed $v_c = 33.75; 42.9; 59.86$ [m/min.],
- feed $f = 0.204$ [mm/turn],
- cutting depth $a_p = 0.75$ [mm],
- dry cutting or machining with cutting-tool lubricant.

During turning, cutting fluid was used in the form of a semi-synthetic emulsion - S455N Statoil Toolway produced in Norway. The PN-ISO 3685:1996 standard on testing high speed steel edges recommends the use of a lubricating and cooling liquid to emphasize abrasive wear of edges, without significant wear due to adhesion, diffusion, thermal or chemical action. In the course of the study, it was observed that in the presence of the cutting emulsion, types of wear other than those resulting from abrasion were practically eliminated.

The durability (or tool life) of the cutting edge is usually understood as the time of until the assumed indicator of the edge blunting value is achieved. Taking into account the wear graphs obtained in the course of the preliminary investigations as well as data from other publications and standards: PN-83/M-58350; PN-ISO 3685, the assumed indicator of the edge blunting value is the band width of the corner wear from the flank face $VB_c = 1.6$ mm. The VB_c value is measured using the Brinell magnifier [3, 9, 10, 14].

The subject matter of the present investigation were cutting inserts made of high speed steel manufactured in the following processes:

- conventionally (HS6-5-2),
- utilizing powder metallurgy (PM6-5-2).

Before handing over the inserts for study, the surfaces of the rake face, flank face and cutting edge were examined. All the inserts were free from defects such as chipping, nicks or cracks.

Fig. 6 shows the wear graphs for cutting edges made of both types of high speed steels – with and without cutting emulsion.

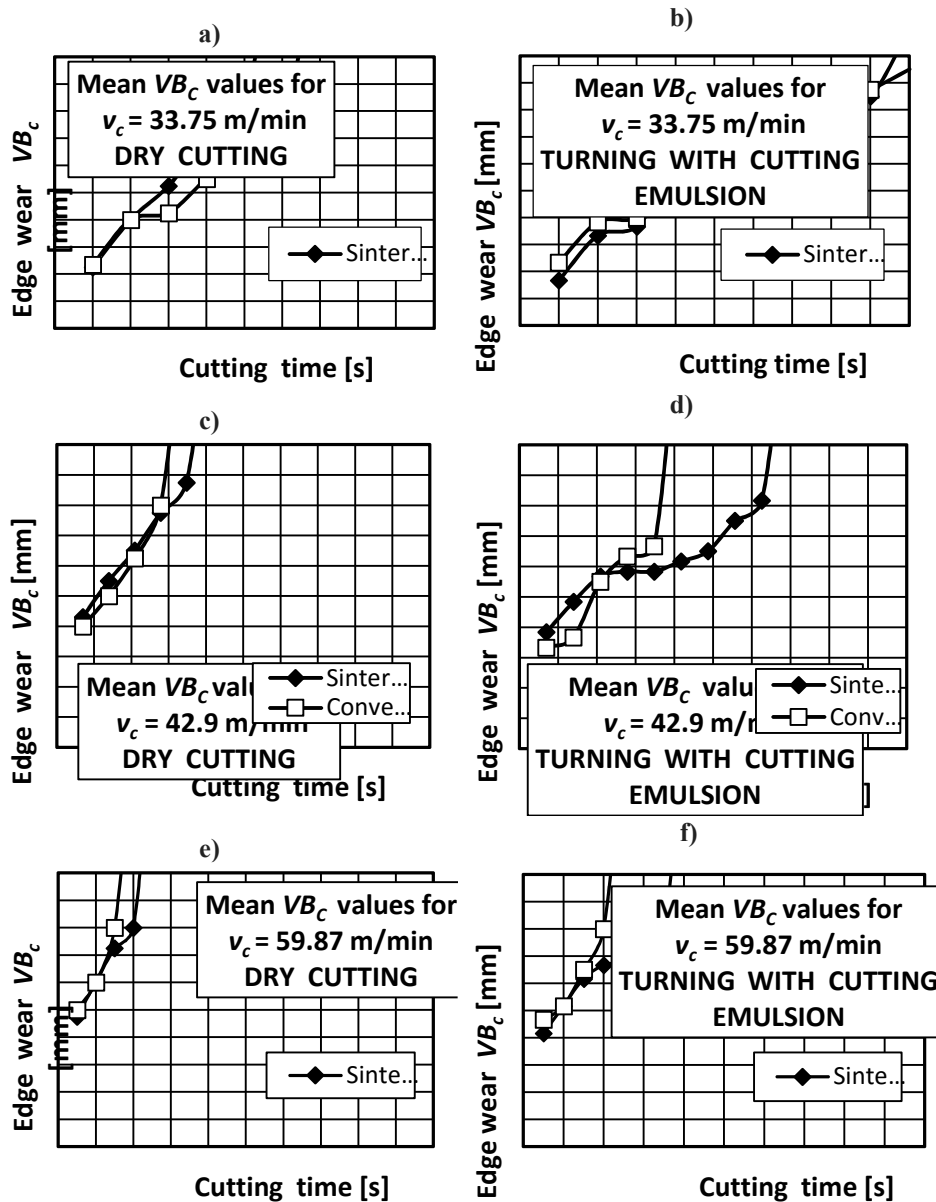

Fig. 6. Wear graphs of cutting edges made of the both HS6-5-2 conventional and the PM6-5-2 sintered steels during machining 40HM-T steel: a, c, e) without and b, d, f) with cutting emulsion for different cutting speeds: a-b) 33.75 m/min, c-d) 42.9 m/min, e-f) 59.87 m/min

Based on the obtained wear graphs, tool life for cutting edges were ascertained at assumed value of the indicator of the edge blunting ($VB_c = 1,6$ mm). The results of the life of tools made of conventional and sintered steel during turning the 40HM-T steel without and with cutting emulsion are indicated in Fig. 7.

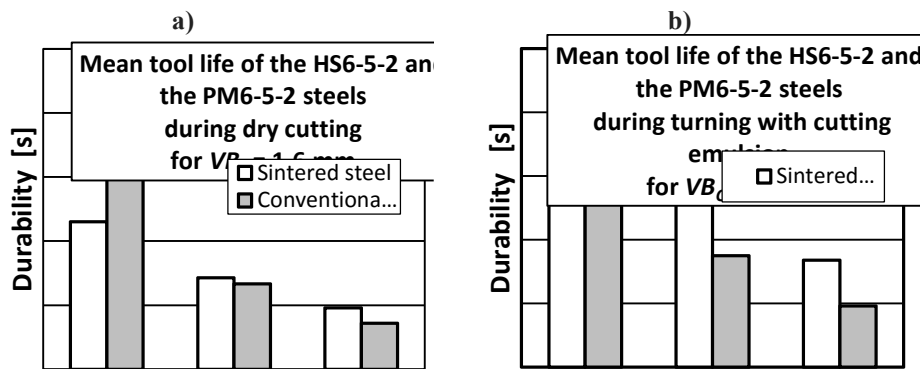

Fig. 7. Mean tool life of edges made of conventional and sintered HSS during machining 40HM-T steel a) without, b) with cutting emulsion

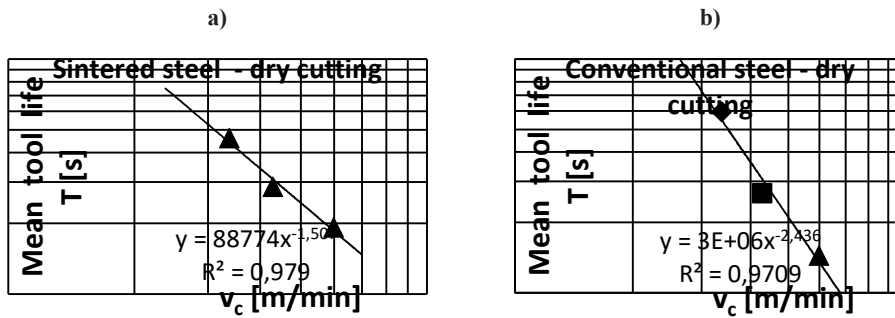

Fig. 8. Graphical determination of the relationship $T = f(v_c)$ on a logarithmic scale for cutting edges made of: a) sintered steel, b) conventional steel during turning without emulsion

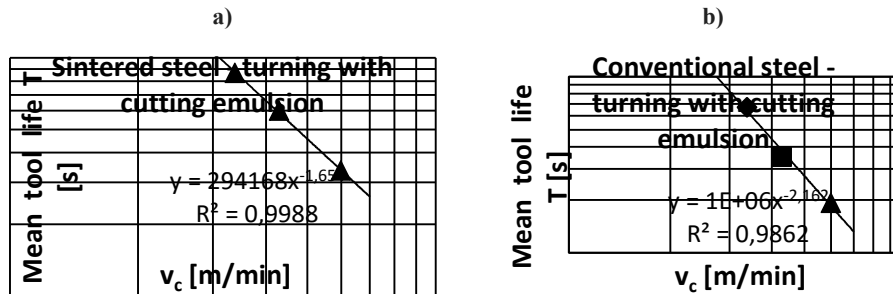

Fig. 9. Graphical determination of the relationship $T = f(v_c)$ on a logarithmic scale for cutting edges made of: a) sintered steel, b) conventional steel during turning with emulsion

4. FINAL CONCLUSIONS

As it results from the performed tests, cutting edges made of sintered steel exhibit slightly better technological properties than edges made of conventional high-speed steel (i.e. higher mean hardness, more uniform distribution of carbides – no occurrence of carbide banding resulting from the forging or rolling processes of conventional high-speed steel).

The study results and the observations made during the investigation of technological properties are reflected in the results of tests of functional properties of the cutting edges used in conjunction with the lubricating and cooling liquid. The cutting edges made of sintered high-speed steel exhibit significantly better durability in comparison with conventional high-speed steel edges at higher cutting speeds ($v_c = 42.9$ m/min and 59.87 m/min).

In the dry cutting conditions (no cooling and lubricating liquid) cutting edges made of conventional high-speed steel at the least of cutting speed ($v_c = 33.75$ m/min) exhibit higher durability than sintered steel. This phenomenon has become the subject of further studies which focus, among others, on the influence of surface morphology on the technological and functional properties of cutting edges.

REFERENCES

- [1] **Barbacki A.**: Materiały w budowie maszyn. Przewodnik do ćwiczeń laboratoryjnych. [Materials in Machine Construction. A guide for Laboratory Classes], Poznań University of Technology Publishing, Poznań, 2003.

- [2] **Bolton JD, Gant AJ.** Heat treatment of PM HSS metal matrix composites, Proceedings of European Conference on Advanced PM Materials, Birmingham, 1995, 1:388-95.
- [3] **Dmochowski J.:** Podstawy obróbki skrawaniem [Machining Basics], PWN, Warszawa 1978.
- [4] **Dobrzański A.:** Metaloznawstwo i obróbka cieplna materiałów narzędziowych [Physical Metallurgy and Thermal Processing of Tool Materials], WNT, Warszawa 1990.
- [5] **Dobrzański A.:** Podstawy nauki o materiałach i metaloznawstwo. Materiały inżynierskie z podstawami projektowania materiałowego [Material Study and Physical Metallurgy Basics. Engineering Materials with Material Design Basics]. WNT, Warszawa 2002.
- [6] **Górski E.:** Poradnik narzędziowca [A Toolmaker's Guidebook]. WNT, Warszawa 1989.
- [7] **Harlin P., Olsson M.:** Abrasive wear resistance of starch consolidated and sintered high speed steel. *Wear* 267 2009, 1482-1489).
- [8] **Jurczyk M., Jakubowicz J.:** Nanomateriały ceramiczne [Ceramic Nanomaterials]. Poznań University of Technology Publishing, Poznań 2004.
- [9] **Kupczyk M.J.:** Wytwarzanie i eksploatacja narzędzi skrawających z powłokami przeciwzużyciowymi, [Manufacturing and Use of Machining Tools with Anti-wear Coating] Poznań University of Technology Publishing, Poznań 2009.
- [10] Materials by Fischer company
- [11] Materials by Sandvik company
- [12] **Mesquita H A., Barbosa C A.,** Evaluation of As-Hipped PM High Speed Steel for Production of Large-Diameter Cutting Tools, *Materials Science Forum*, Vols. 416-418, pp. 235-240, Feb. 2003
- [13] **Mesquita R. A., Barbosa C A.,** High-Speed Steels Produced by Conventional Casting, Spray Forming and Powder Metallurgy, *Materials Science Forum*, Vols. 496-499, pp. 244-250, Nov. 2005
- [14] **Olszak W.,** Obróbka skrawaniem, WNT, Warszawa 2008.
- [15] **Zhang G.** et al Microstructure evolution and mechanical properties of T15, high speed steel prepared by twin-atomiser spray forming and thermo-mechanical processing, *Materials Science & Engineering, A* 558 (2012) 566-571

PORÓWNAWCZE BADANIA WŁAŚCIWOŚCI TECHNOLOGICZNYCH I
EKSPLOATACYJNYCH OSTRZY SKRAWAJĄCYCH Z KONWENCJONALNEJ I
SPIEKANEJ STALI SZYBKOTNĄCEJ

W artykule przedstawiono wybrane fragmenty badań właściwości technologicznych i eksploatacyjnych ostrzy skrawających z konwencjonalnej i spiekanej stali szybko tnącej o podobnym składzie chemicznym. Badania właściwości technologicznych i eksploatacyjnych mają charakter porównawczy i dotyczą m.in. oceny składu chemicznego, twardości i struktury oraz trwałości w procesie skrawania stali do ulepszenia cieplnego. Na końcu artykułu zamieszczono wnioski z przeprowadzonych badań.

Słowa kluczowe: konwencjonalne i spiekane stale szybko tnące, właściwości