



Cent. Eur. J. Energ. Mater. 2021, 18(1): 143-158; DOI 10.22211/cejem/135119

Article is available in PDF-format, in colour, at:

http://www.wydawnictwa.ipo.waw.pl/cejem/Vol-18-Number1-2021/CEJEM_01094.pdf



Article is available under the Creative Commons Attribution-Noncommercial-NoDerivs 3.0 license CC BY-NC-ND 3.0.

Research paper

Novel Composite Solid Propellant with High Resistance to Thermo-oxidative Degradation Reactions, Extended Shelf Life, and Superior Combustion Characteristics

Sherif Elbasuney^{1,2,*}, Eslam Elsaka¹, Ahmed Elbeih¹,
Hosam E. Mostafa¹

¹ School of Chemical Engineering, Military Technical College,
Kobry Elkoba, Cairo, Egypt

² Head of Nanotechnology Research Center,
Military Technical College, Cairo, Egypt

* E-mails: s.elbasuney@mtc.edu.eg; sherif_basuney2000@yahoo.com

Abstract: Hydroxy-terminated polybutadiene (HTPB) pre-polymer is the main constituent that is responsible for conferring high mechanical properties on composite solid propellants. However, HTPB pre-polymer suffers from oxidative degradation reactions that diminish its mechanical properties and shelf life. Composite solid propellant formulations based on an advanced stabilizing agent (anti-oxidant), Flexzone 6-H, with different curing ratios, 0.7 and 1.1, were developed *via* mixing and casting under vacuum. The developed formulations were subjected to artificial ageing using Vant Hoff's formula by isothermal heating at 80 °C for up to 35 days. The change in strain with ageing was evaluated using a uni-axial tensile test. The propellant formulation based on a curing ratio of 0.7 demonstrated a high ageing resistance coefficient and an extended service life of up to 15 years, compared with 5 years for higher curing ratio. A propellant grain is considered to be 'aged out' at 30% reduction in its maximum strain value. The propellant formulation based on the 0.7 curing ratio exhibited superior thermal stability as it offered a minimum decrease in heat released after ageing using DSC. Additionally, the 0.7 curing ratio formulations exhibited a minimum change in burning rate and pressure exponent with ageing time. It can be concluded that the propellant with 0.7 curing ratio can maintain its mechanical, thermal, and ballistic properties with ageing.

Keywords: composite propellants, ageing, mechanical properties, curing ratio, combustion

1 Introduction

The ageing process of an hydroxy-terminated polybutadiene (HTPB) composite propellant is a complex process as different oxidative degradation reactions could take place simultaneously during the ageing time [1]. Propellant ageing could be initiated through several processes, including chemical, physical, and mechanical [2, 3] (Figure 1), *i.e.*:

- Chemical degradation processes include oxidative cross-linking, chain scission *via* hydrolysis, oxidative attack, antioxidant depletion, and binder oxidation.
- Physical processes include plasticizer migration, humidity, presence of liquid burn catalyst (depletion by migration), phase transition, and de-wetting.
- Mechanical processes include vibration, thermally induced stresses through temperature cycle effects, liner separation, and cracks.

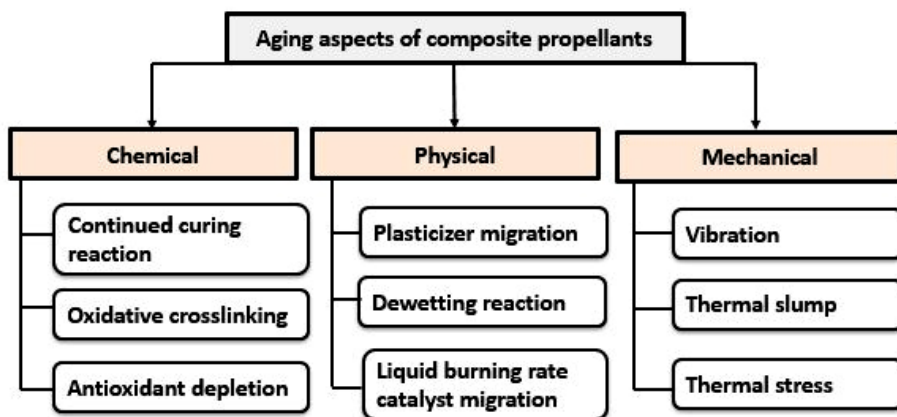

Figure 1. Main ageing aspects of composite propellants

It is widely accepted that the dominant ageing reaction is an oxidative cross-linking reaction of the π bonds in the backbone of the HTPB pre-polymer [4, 5]. The π bonds are vulnerable to air oxygen and attack by different free radicals. These damaging reactions could be reduced by the introduction of advanced antioxidants, such as Flexzone-6H [6]. This antioxidant can minimize the oxidative

degradation reactions by capture of any generated free radicals [7, 8]. It is widely accepted that all types of degradation reactions could affect the mechanical properties of solid propellants. Their mechanical properties can be explored using uni-axial tensile testing, which can be employed as a quick quality control tool in propellant development and production [9, 10]. The stress-strain curves can be utilized to assess the service life of propellants (Figure 2).

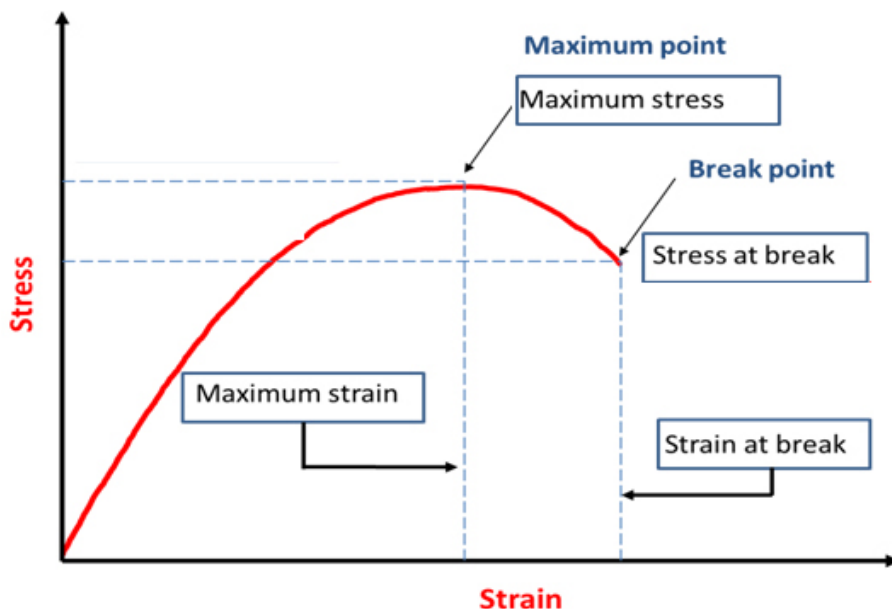

Figure 2. Typical (stress-strain) curve for composite propellants

The mechanical characteristics of composite propellants must meet certain acceptance limits of stress and strain in order to withstand the severe mechanical and thermal stresses during firing [11, 12]. It is reported that HTPB/AP/Al composite propellant formulations can withstand a wide range of stress and strain values. The accepted limits for the mechanical properties of a composite solid propellant are tabulated in Table 1.

Table 1. Mechanical characteristic limits of composite propellants

Temperature [°C]	-30		+ 50	
Parameter	Max. stress [MPa]	Max. strain [%]	Max. stress [MPa]	Max. strain [%]
HTPB/AP/Al	6.27 : 3.58	50 : 23	1.57 : 0.62	10 : 33

Polyurethanes (PUs) based on HTPB are versatile thermosetting polymers for composite propellant applications. They are capable of accommodating high solid loading level, up to 86 wt.%, with high stress and strain values [13, 14]. Ageing could reduce the high mechanical properties of a PU binder. A propellant formulation is considered to be ‘aged out’ if it loses 30% of its initial maximum strain value. Furthermore, the ageing process could significantly reduce the activation energy required for ignition of a solid propellant. It is widely accepted that this activation energy will decrease with ageing [15]. The activation energy can be represented by the Arrhenius equation (Equation 1) [12, 16]:

$$k = Ae^{\left(\frac{-E_a}{RT}\right)} \quad (1)$$

where k , A , E_a , R , T are the reaction rate constant, Arrhenius constant, activation energy, universal gas constant, and absolute temperature, respectively. Equation 1 represents a straight forward route for the evaluation of E_a with ageing.

The shelf life of a composite propellant can be evaluated *via* artificial ageing, where a propellant grain is subjected to thermal stress (in days) that is equivalent to normal stresses at 25 °C over several years [11]. Composite propellant ageing can significantly reduce the mechanical properties, and these are significantly influenced by the curing ratio [17]. The (NCO/OH) molar ratio plays a critical role in the cross-linking kinetics and in the mechanical properties of the resultant solid propellant formulation [18]. In the present study, different propellant formulations with curing ratios of 0.7 and 1.1 were developed. Artificial ageing was conducted using Vant Hoff’s formula by isothermal heating at 80 °C for 35 days. The influence of the curing ratio on the mechanical, thermal, and combustion characteristics were evaluated using uni-axial tensile testing, DSC, and small-scale ballistic rocket motor evaluation, respectively. Changes in the stress and strain with ageing were evaluated using the uni-axial tensile test. A propellant formulation based on 0.7 curing ratio demonstrated an extended service life of up to 15 years, compared with 5 years for higher curing ratios; a propellant grain is considered to be ‘aged out’ if it loses 30% of its strain value. The propellant formulation based on 0.7 curing ratio demonstrated superior thermal stability as it offered a minimum decrease in the total heat released with ageing as measured by DSC. Additionally, a formulation with 0.7 curing ratio demonstrated a minimum change in burning rate with ageing time, reduced by -1.10% compared with -3.45% for higher curing ratios. Furthermore, a 0.7 curing ratio demonstrated a minimum change in the pressure exponent with ageing time. It can be concluded that a propellant with 0.7 curing ratio can maintain its mechanical, thermal, and ballistic properties with ageing.

2 Experimental

2.1 Materials and formulations

The main solid additives included crystalline ammonium perchlorate (AP, average particle sizes of 400, 200, and 7-11 μm) as an oxidizer, aluminum powder (average particle size of 20 μm) as a metal fuel, di-octyl adipate (DOA) as a plasticizer (Alpha Chemica). The employed pre-polymer consisted of HTPB with 0.584 mg·eqv.OH/g (Aldrich). The curing agent was hexamethylene diisocyanate (HMDI) with 11.86 mg·eqv.NCO/g (Aldrich). *N,N'*-Diphenyl-*p*-phenylenediamine (Flexzone 6-H) was employed as an advanced anti-oxidant. The prepared formulations were designed and listed in Table 2.

Table 2. Prepared propellant formulations

Ingredient	Content [wt.%]	
	F1	F2
AP, grain size [μm]:		
– 400		43
– 200		16
– 7-11		12
Al (20 μm)		14
Fuel binder:		
– HTPB	11.33	10.98
– HMDI	0.63	0.98
– DOA		2.54
Antioxidant (Flexzone 6-H)		0.5
Curing ratio (NCO/OH)	0.7	1.1

2.2 Development of the composite propellant

Composite solid propellant formulations were developed by mixing under vacuum, followed by vacuum casting under mechanical vibration. Each developed formulation was cast into a casing mould. The cast propellants were cured in an electrical oven at 55 °C for 6 days.

2.3 Artificial ageing

The samples for ageing were stored in a block shape (carton block) to simulate the propellants of large-scale motors [15]. Each aged sample was cut into slices of specific thickness.

Vant Hoff's formula is widely accepted as an effective tool to facilitate shelf life assessment [15] (Equation 2).

$$t_E = t_T \cdot F^{\frac{(T_T - T_E)}{\Delta T_F}} / 365.25 \quad (2)$$

where t_E is the in-service temperature (years), t_T is the test time at the ageing temperature T_T (days), F is the reaction rate change factor per 10 °C temperature change, and ΔT_F is the temperature interval for the actual value of F . The propellant formulations were aged by isothermal heating at 80 °C for 35 days, with a scaling factor $F = 2.5$ [11, 19]. The ageing period (in days) and corresponding in-service life (in years) are tabulated in Table 3.

Table 3. Applied accelerated ageing program

In-service temperature [°C]	In-service time t_E [year]		
25	5	10	15
Accelerated ageing conditions [day]			
90	5	10	15
80	12	24	35
70	30	60	90

2.4 Mechanical properties with ageing

The specimens for mechanical testing were cut into dumbbell-shaped pieces (Figure 3). For reliable data each tested specimen was subjected to a relaxation period of 48 h to avoid any thermal or mechanical load. There are many changes in stress and strain values of a propellant grain with ageing. A propellant grain is considered ‘aged out’ at 30% reduction in its maximum strain value [20].

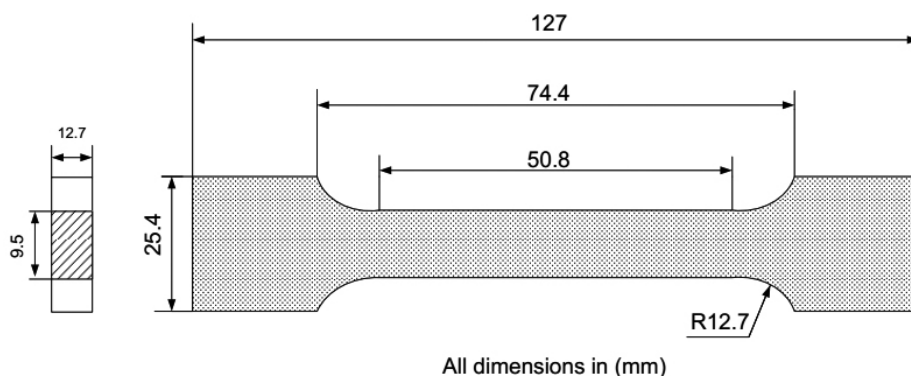

Figure 3. JANNAF specimen for mechanical testing [21]

The mechanical properties of the cured propellants were investigated using a tensile strength tester (Zwick Z050 universal test machine) according to ASTM D412 at a crosshead speed of 50 mm/min at room temperature. The ageing resistance coefficient (K) can be employed to evaluate the propellant's resistance to ageing. A high K value reflects a higher resistance to mechanical deterioration [22]. The K coefficient can be represented using the f factor (Equation 3):

$$f_i = \sigma_{(\text{break})} \cdot \varepsilon_{(\text{break})} \quad (3)$$

where $\sigma_{(\text{break})}$ and $\varepsilon_{(\text{break})}$ are the tensile strength at break and elongation at break, respectively. The ageing coefficient is a dimensionless parameter; it correlates the change in the f factor of an aged grain to a fresh grain (Equation 4):

$$K = f_2/f_1 \quad (4)$$

where f_1 , and f_2 are the f factors of a fresh formulation and an aged formulation, respectively.

2.5 Thermal behaviour with ageing

Changes in the thermal properties, particularly the ignition temperature as well as the total heat released, were evaluated against the ageing period using differential scanning calorimetry (DSC) using a Q2000 instrument by Thermo-scientific (USA). The tested samples were heated from 50 to 400 °C at 20 °C/min, under a constant flow of nitrogen at 30 mL/min.

2.6 Combustion characteristics with ageing

Changes in the combustion characteristics, particularly the burning rate, was evaluated against the ageing period using a small-scale ballistic evaluation test motor. A propellant grain of length 108 mm, outer diameter (OD) 60 mm, inner diameter 34 mm with an inhibited OD was assembled within the small-scale motor casing (Figure 4(a)). The operating pressure was recorded during combustion using a standardized pressure transducer (Figure 4(b)).

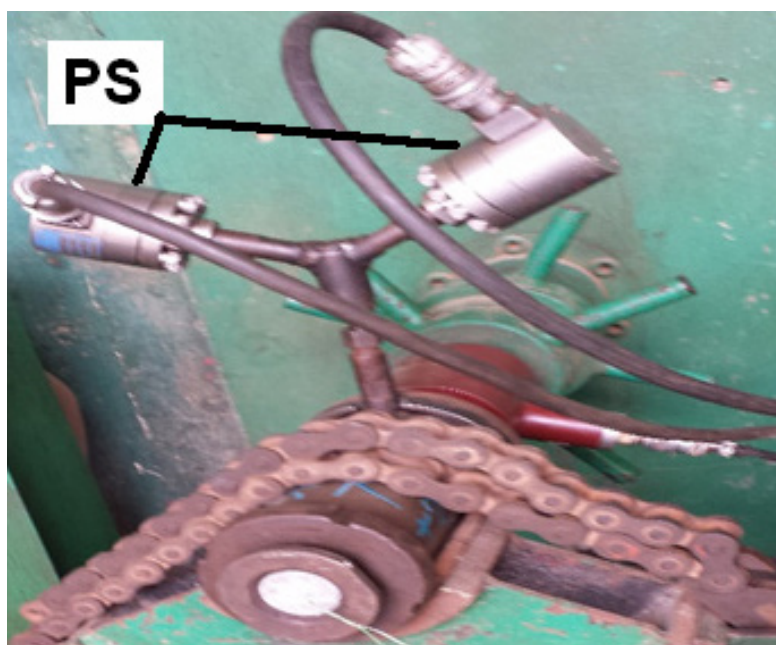
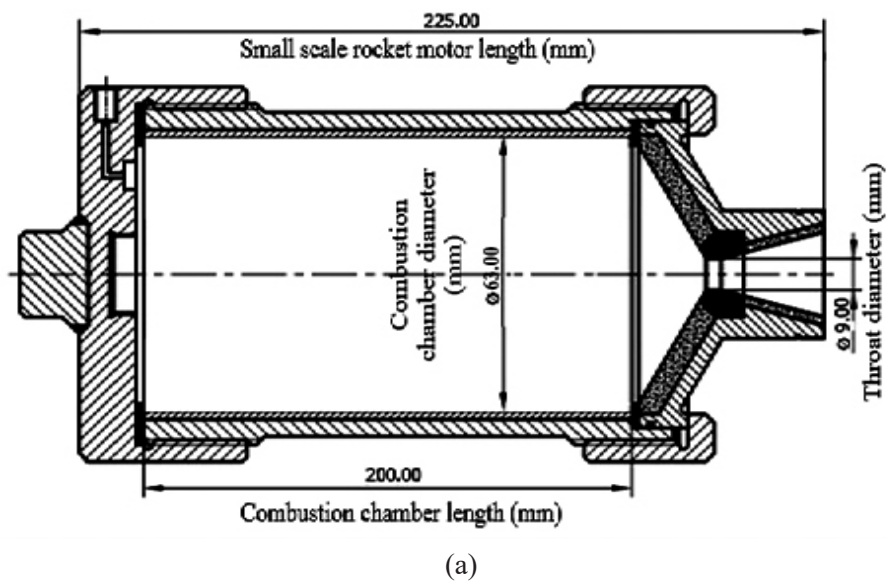

Figure 4. Schematic for small scale test motor (a), static firing test (b), where PS is a pressure transducer

The burning rate was evaluated from the action burning time and the web thickness of the propellant grain. The burning rate *vs.* pressure relationship can be represented by Ville's equation (Equation 5):

$$r = a P^n \quad (5)$$

where *r*, *a*, *P*, and *n* are the linear burning rate, burning rate constant, chamber pressure, and pressure exponent, respectively. The influence of the ageing period on the burning rate pressure exponent (*n*) was evaluated. Different aged grains were tested at different operating pressures to determine the burning rate law and to calculate the pressure exponent *n*. The influence of the curing ratio on the pressure exponent *n* with ageing period was also evaluated.

3 Results and Discussion

3.1 Influence of the curing ratio on the mechanical properties

The curing reaction of the HTPB pre-polymer with di-isocyanate is a polyaddition polymerization reaction without by-products. A cured polyurethane binder is classified as a thermosetting polymer (Scheme 1).

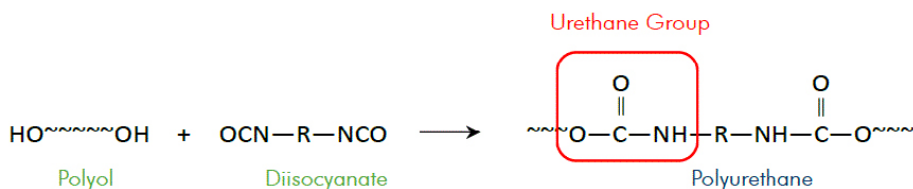

Scheme 1. Curing reaction of a polyol pre-polymer with a di-isocyanate

The π bonds present along the cured polymer chains are responsible for enhanced elasticity (high strain value). A minimal change in the NCO/OH molar ratio will have a dramatic influence on the mechanical properties (stress and strain values). The influence of the curing ratio on the mechanical properties of a propellant grain is represented in Figure 5.

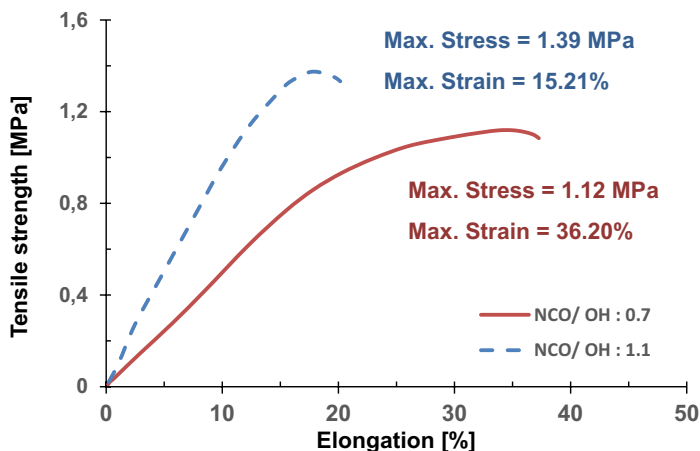

Figure 5. Influence of the curing ratio on the mechanical characteristics of the composite propellant

The formulation based on 0.7 curing ratio conferred an acceptable max. stress value with an increase in the strain value of 138.2% compared to the higher curing ratio. Therefore a 0.7 curing ratio could provide a more elastic grain that could accommodate higher stress values during ageing.

3.2 Changes in the mechanical properties with ageing

Changes in the max. stress value with ageing time was investigated for curing ratios 0.7 and 1.1. There was an increase in the max. stress value with ageing period (Figure 6).

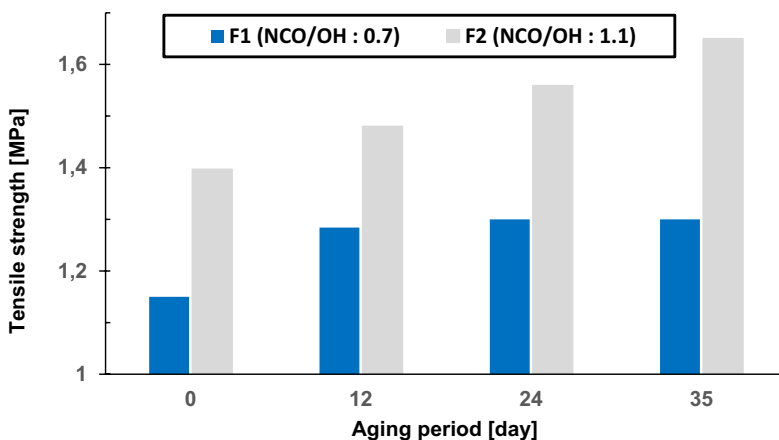

Figure 6. Variation of tensile strength with ageing

It is apparent that there is a dramatic change in the max. stress value with ageing for a curing ratio of 1.1 compared to a 0.7 curing ratio. This can be ascribed to oxidative cross linking reactions; a high NCO/OH ratio was found to accelerate the oxidation of HTPB-based polyurethanes during thermal ageing [23]. Changes in strain with ageing was also investigated for different curing ratios. There was decrease in the strain value with ageing period (Figure 7).

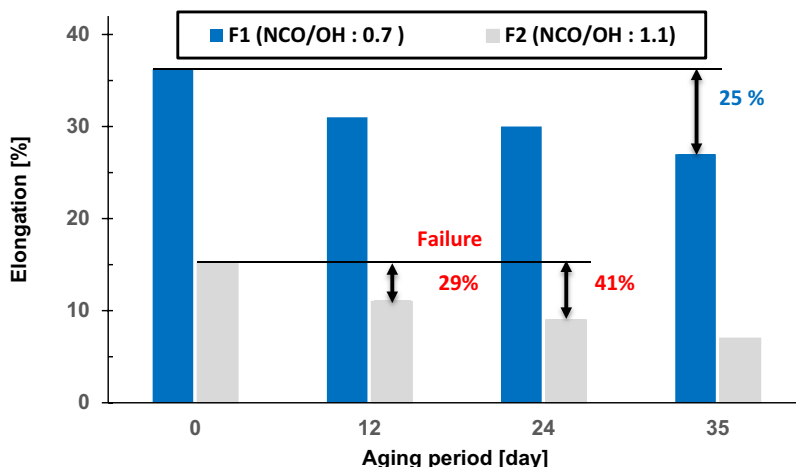

Figure 7. Variation of strain value with ageing

A 0.7 curing ratios conferred a high strain value with minimal strain decrease with ageing time. By contrast a 1.1 curing ratio exhibited a low strain value with a dramatic decrease with ageing time. A propellant grain is considered to be ‘aged out’ if it loses 30% of its original strain value. A 1.1 curing ratio was found to be ‘aged out’ after 12 days (5 years shelf life), with a 29% loss of its strain value. The 0.7 curing ratio exhibited an extended shelf life of up to 15 years. The f factor for each curing ratio was calculated according to Equation 3, and the ageing coefficient value for each curing ratio was calculated according to Equation 4. A summary of the changes in the mechanical properties with ageing time is tabulated in Table 4.

Table 4. Main mechanical parameter values

Propellant	Curing ratio	Fresh			After 35 days at 80 °C			K
		σ [MPa]	ε [%]	f_1	σ [MPa]	ε [%]	f_2	
F1	0.7	1.068	38.2	0.407	1.186	27.3	0.32	0.786
F2	1.1	1.451	14.6	0.211	1.588	7.8	0.12	0.560

The higher the ageing coefficient, the better the thermo-oxidative ageing resistance will be. The 0.7 curing ratio conferred a higher ageing coefficient compared with the 1.1 value. This can be ascribed to a higher resistance to oxidative degradation, therefore an extended service can be achieved.

3.3 Changes in the thermal properties with ageing

Changes in the total heat released with ageing time was measured using DSC for different curing ratios. In general there was a decrease in the total heat released with ageing (Figure 8) [24]. The total heat released by fresh and grains aged for 35 days is shown in Figure 8. A heating rate of 20 °C/min was applied for all of the tested samples to provide a comparative thermal study between fresh and aged propellants, for different curing ratios. Kinetic decomposition with ageing (using different heating rates) was further investigated in another study (not included here).

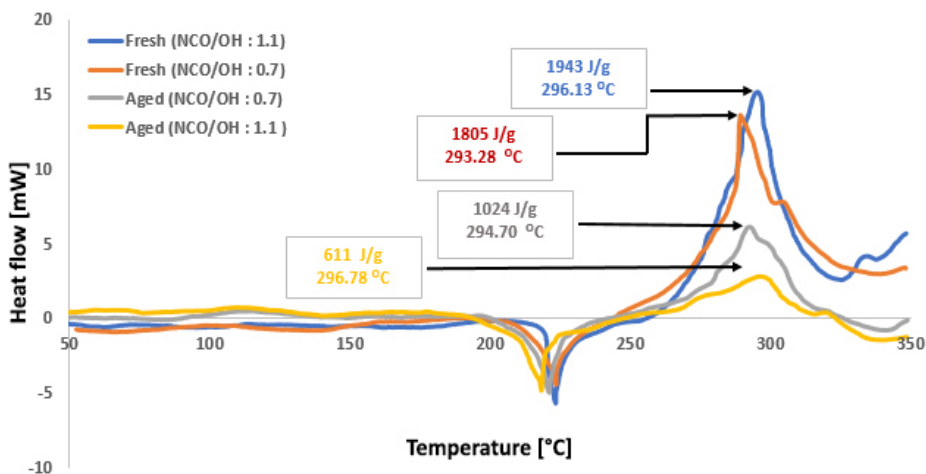

Figure 8. DSC thermograms of fresh and aged formulations after 35 days at 80 °C

It is apparent that formulations with a 0.7 curing ratio demonstrated a minimum change in total heat released of -43%, compared with -68.5% for a 1.1 curing ratio.

3.4 Combustion characteristics with ageing

The pressure-time curves of composite propellants with different curing ratios were recorded (Figure 9). Both formulations demonstrated a stable

combustion process; it can be concluded that there is a minimal influence of cross-linking ratio on the operating pressure and burning rate values.

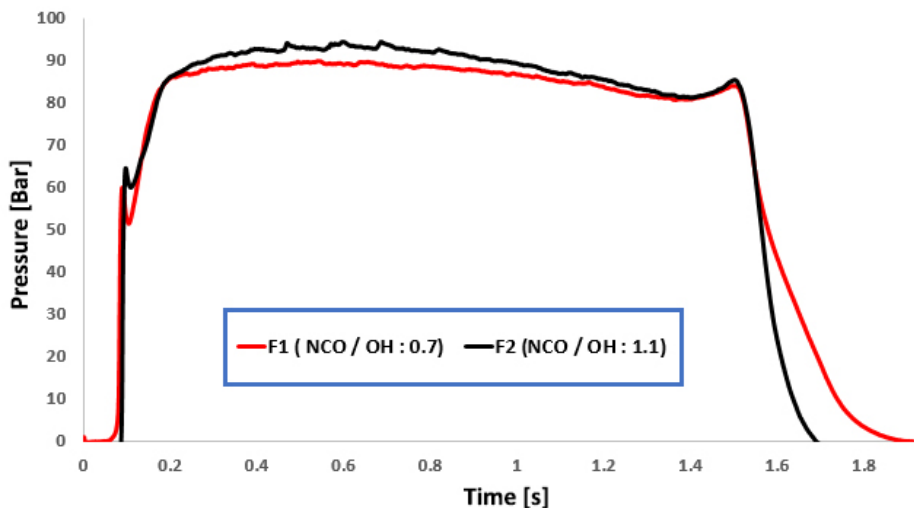

Figure 9. Influence of curing ratio on the pressure-time curves

The burning rate value was calculated from the action time and web thickness. Aged formulations were tested in an attempt to evaluate the influence of curing ratio on burning rate with ageing. In general, there was an increase in burning rate with ageing; this can be ascribed to the increase in the oxidative cross-linking reaction with ageing [25]. Whereas a 0.7 curing ratio demonstrated a minimum change in burning rate with ageing time, with an increase of 1.1%, compared with 3.45% for a 1.1 curing ratio.

The value of the pressure exponent n (see Equation 5) is the main key parameter that could significantly affect burning stability [26]. A propellant grain, that could withstand ageing without change in n value, could offer invariant ballistic performance. The influence of curing ratio on n was evaluated with ageing time for a fresh formulation and a formulation aged for 35 days. The propellant grains were tested at different operating pressures to derive the n value (Figure 10).

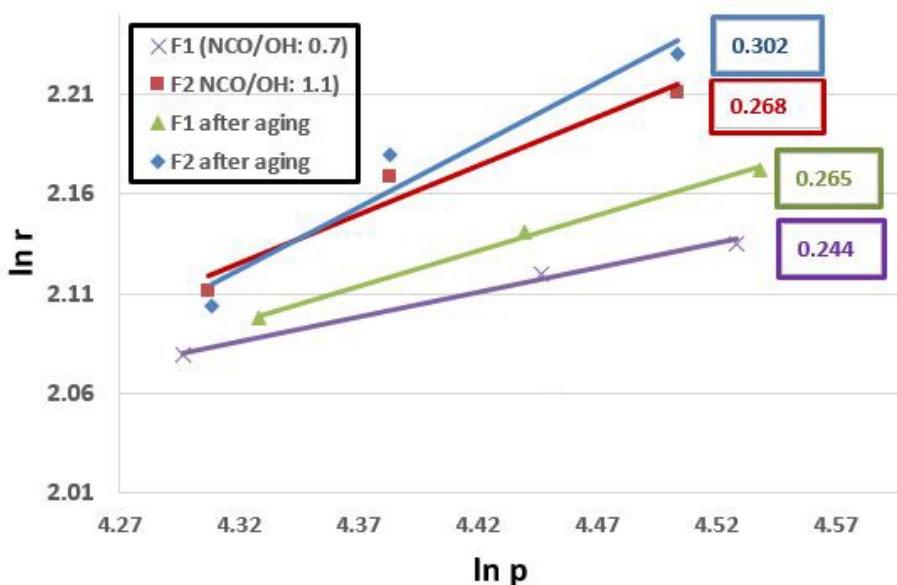

Figure 10. Influence of curing ratio on the pressure exponent n with ageing time

It is obvious that there is an increase in the pressure exponent value with ageing. However, a 0.7 curing ratio demonstrated a small change in the pressure exponent value with ageing time. Whereas a 0.7 curing ratio demonstrated an increase in the n value of 8%, the higher curing ratio demonstrated an increase in the n value of 12.6%.

4 Conclusions

- ◆ The curing ratio had a significant influence on the mechanical, thermal, ballistic, and shelf life of the composite solid propellants.
- ◆ Changes in the strain value with ageing demonstrated that the propellant formulation based on a 0.7 curing ratio could offer an extended service life of up to 15 years, compared with 5 years with the higher curing ratio. Furthermore a 0.7 curing ratio exhibited a higher thermo-oxidative resistance, with a higher ageing resistance coefficient compared with the higher curing ratio. This behaviour confirmed the higher resistance to oxidative degradation. Additionally a 0.7 curing ratio exhibited superior thermal stability with minimum decrease in heat released on ageing.
- ◆ It could be concluded that a propellant formulation based on a 0.7 curing ratio

is favorable for propellants designed for enhanced mechanical characteristics and extended service life of the HTPB/AP/Al type of composite propellant.

References

- [1] Cerri, S.; Bohn, M.A.; Menke, K.; Galfetti, L. Ageing of HTPB/Al/AP Rocket Propellant Formulations Investigated by DMA Measurements. *Propellants Explos. Pyrotech.* **2013**, *38*(2): 190-198.
- [2] Tussiwand, G.; Eineder, L.; Mussbach, G.; Bohn, M.A. Non-destructive Ageing State Determination of Solid Rocket Motors Charges. *8th European Workshop On Structural Health Monitoring (EWSHM 2016)*, Bilbao, Spain, 2016, pp. 5-8.
- [3] Villar, L.D.; da Silva, R.F.; Diniz, M.F.; Takahashi, M.F.K.; Rezende, L.C. The Role of Antioxidant on Propellant Binder Reactivity During Thermal Ageing. *J. Aerosp. Technol. Manag.* **2010**, *2*(2): 163-168.
- [4] Coquillat, M.; Verdu, J.; Colin, X.; Audouin, L.; Nevie, R. Thermal Oxidation of Polybutadiene. Part 1: Effect of Temperature, Oxygen Pressure and Sample Thickness on the Thermal Oxidation of Hydroxyl-terminated Polybutadiene. *Polym. Degrad. Stab.* **2007**, *92*: 1326-1333.
- [5] Celina, M.; Skutnik Elliott, J.M.; Winters, S.T.; Assink, R.A.; Minier, L.M. Correlation of Antioxidant Depletion and Mechanical Performance During Thermal Degradation of an HTPB Elastomer. *Polym. Degrad. Stab.* **2006**, *91*(8): 1870-1879.
- [6] Désilets S.; Côté, S. Chemical Bond Between Stabilizers and HTPB Binders in Propellants. *Propellants Explos. Pyrotech.* **2000**, *25*: 186-190.
- [7] Fiorio, R.; D'hooge, D.R.; Ragaert, K.; Cardon, L. A Statistical Analysis on the Effect of Antioxidants on the Thermal-Oxidative Stability of Commercial Mass- and Emulsion-Polymerized ABS. *Polymers* **2019**, *11*(25): 1-15
- [8] Coquillat, M.; Verdu, J.; Colin, X.; Audouin, L.; Celina, M. A Kinetic Evaluation of the Thermal Oxidation of a Phenol Stabilised Polybutadiene. *Polym. Degrad. Stab.* **2008**, *93*: 1689-1694.
- [9] Shekhar, H. Effect of Temperature on Mechanical Properties of Solid Rocket Propellants. *Def. Sci. J.* **2011**, *61*(6): 529-533.
- [10] Shekhar, H. Prediction and Comparison of Shelf Life of Solid Rocket Propellants Using Arrhenius and Berthelot Equations. *Propellants Explos. Pyrotech.* **2011**, *36*(4): 356-359.
- [11] Cerri, S.; Bohn, M.A.; Menke, K.; Galfetti, L. Ageing Behaviour of HTPB Based Rocket Propellant Formulations. *Cent. Eur. J. Energ. Mater.* **2009**, *6*(2): 149-165.
- [12] Judge, M.D. An Investigation of Composite Propellant Accelerated Ageing Mechanisms and Kinetics. *Propellants Explos. Pyrotech.* **2003**, *28*(3): 114-119.
- [13] Mahanata, A.K.; Pathak, D.D. HTPB-Polyurethane: a Versatile Fuel Binder for Composite Solid Propellant. In: *Polyurethane*. **2012**, Ch. 11, pp. 229-262; ISBN 9789535107262.
- [14] Göçmez, A.; Erişken, C.; Yilmazer, Ü.; Pekel, F.; Özkar, S. Mechanical and Burning

- Properties of Highly Loaded Composite Propellants. *J. Appl. Polym. Sci.* **2002**, *67*(8): 1457-1464.
- [15] Sanecka, P.W.; Florczak, B.; Maranda, A. Investigation of Properties of Heterogeneous Solid Rocket Propellants after Accelerated Aging. *CHEMIK* **2016**, *70*(1): 23-26.
- [16] Yongqiang, D.; Jian, Z.; Wei, P.; Xiao, Z. Hydrothermal Ageing Life Model of Composite Solid Propellant Based on Modified Arrhenius Method. *Proc. Int. Symp. on Material, Energy and Environment Engineering (ISM3E)*, **2015**, pp. 162-165.
- [17] Nawwar, M.S.; Wafy, T. Z.; Mustafa, H.E. Performance of Composite Solid Rocket Propellants for Rocket Assisted Projectiles (RAP). *Proc. 8th I.C.E.E. Conf.*, Cairo, Egypt, **2016**, 229-242.
- [18] Zhang, L.; Zheng, X. Experimental Study on Thermal Decomposition Kinetics of Natural Ageing AP/HTPB Base Bleed Composite Propellant. *Def. Technol.* **2018**, *14*(5): 422-425.
- [19] Seyidoglu, T.; Bohn, M.A. Characterization of Ageing Behavior of Butacene Based Composite Propellants by Loss Factor Curves. *Propellants Explos. Pirotech.* **2017**, *42*(7): 1-13.
- [20] Shekhar, H. Studies on Stress-Strain Curves of Aged Composite Solid Rocket Propellants. *Def. Sci. J.* **2012**, *62*(2): 90-94.
- [21] Adel, W.M.; Liang, G. Service Life Prediction of AP/Al/HTPB Solid Rocket Propellant with Consideration of Softening Ageing Behavior. *Chin. J. Aeronaut.* **2019**, *32*(2): 361-368.
- [22] Wu, W.; Zeng, X.; Li, H.; Lai, X.; Li, F.; Guo, J. Synthesis and Characterization of a Novel Macromolecular Hindered Phenol Antioxidant and Its Thermo-oxidative Ageing Resistance for Natural Rubber. *J. Macromol. Sci. Part B Phys.* **2014**, *53*(7): 1244-1257.
- [23] Villar, L.D.; Cicaglioni, T.; Diniz, F.M.; Ferreira Koyama Takahashia, M.; Rezendea, L.C. Thermal Ageing of HTPB/IPDI-based Polyurethane as a Function of NCO/OH Ratio. *Mater. Res.* **2011**, *14*(3): 372-375.
- [24] Elbasuney, S.; Yehia, M.; Zaky, M.G.; Radwan, M. MWNTs Coated with CuO Particles: A Novel Nano-catalyst for Solid Propellants. *J. Inorg. Organomet. Polym. Mater.* **2019**, *29*: 2064-2071.
- [25] Hocaoglu, Ö.; Özbelge, T.; Pekel, F.; Özkar, S. Ageing of HTPB/AP-based Composite Solid Propellants, Depending on the NCO/OH and Triol/Diol Ratios. *J. Appl. Polym. Sci.* **2001**, *79*(6): 959-964.
- [26] Fahd, A.; Mostafa, H.E.; Elbasuney, S. Certain Ballistic Performance and Thermal Properties Evaluation for Extruded Modified Double-base Propellants. *Cent. Eur. J. Energ. Mater.* **2017**, *14*(3): 621-635.

Received: September 8, 2019

Revised: March 29, 2021

First published online: March 30, 2021