

STUDY OF PARAMETERS OF THE MIXTURE AND HEAT GENERATION OF THE DD15 DIESEL ENGINE OF THE SANDVIK LH514 LOADER IN THE PROCESS OF USING ALTERNATIVE FUELS BASED ON RME

Michał BEMBENEK^{*✉}, Vasyl MELNYK^{**✉}, Yurii MOSORA^{**✉}

^{*}Department of Manufacturing Systems, Faculty of Mechanical Engineering and Robotics, AGH University of Krakow, al. Adama Mickiewicza 30, 30-059 Kraków, Poland

^{**}Ivano-Frankivsk National Technical University of Oil and Gas, 15 Karpatska St., Ivano-Frankivsk, Ukraine

bembenek@agh.edu.pl, vasyl.melnyk@nung.edu.ua, yuramosora@gmail.com

received 20 June 2023, revised 3 September 2023, accepted 4 September 2023

Abstract: Today, there is a growing shortage of commercial motor fuels in the world. This is due to the tendency to regulate the extraction of hydrocarbons, which are the main raw materials for their production; and, therefore, to reduce the import of oil, alternative types of fuel for diesel engines based on oils and animal fats are becoming widespread today. In this regard, intensive work is underway to convert internal combustion engines to biofuel-based ones both in countries with limited fuel and energy resources and in highly developed countries that have the opportunity to purchase liquid energy carriers. Biodiesel fuel (biodiesel, PME, RME, FAME, EMAG, etc.) is an environmentally friendly type of biofuel obtained from vegetable and animal fats and used to replace petroleum diesel fuel. According to the results of modelling, in the process of using RME B100 biodiesel fuel, we found a reduction in nitrogen dioxide emissions by 21.5% and a reduction in soot emissions by 34.5%. This will positively affect the environmental performance of the Sandvik LH514 loader, which is especially relevant in closed environments such as mines. So, according to the results of studies of the operation of the DD15 engine of the Sandvik LH514 loader on commercial and RME B100 biodiesel fuel, it was established that the use of biodiesel fuel leads to a deterioration of the mixture, due to which heat generation is reduced and, as a result, fuel consumption increases and engine power decreases, but the aspect of environmental indicators constitutes the significant improvement demonstrated by the present work.

Key words: engine, alternative fuels, biodiesel, economy, spraying, mixing, heat release, consumption, power

1. INTRODUCTION

The use of alternative fuels in internal combustion engines (ICE) will lead to a change in the working process in the cylinders of the ICE, and this change may lead to a violation of the engine's operating mode, and a decrease in reliability and durability.

Therefore, the question of researching mixture and heat formation in DD15 diesel engines in the process of using RME B100 biodiesel fuel is relevant, and the results will help to eliminate or reduce negative factors that lead to the deterioration of technical and operational indicators of diesel engines.

Scientists [1–15] have conducted research on methods of reducing emissions of harmful substances and soot by diesel engines in the process of using commercial diesel fuel and biodiesel.

Thus, in Horibe et al. [1], the effect of reducing smoke after fuel injection due to changing the number of nozzle injection holes and injection pressure was established. The results showed that the smoke output of the six-hole, seven-hole and eight-hole nozzles was reduced. It has also been demonstrated in the literature [2–5] that additional fuel injection reduces soot emissions of various engine designs and at various operating points. Horibe et al. [6] investigate the effect of post-injection smoke reduction by changing numerous parameters: number of post-injections, post-injection time, injection pressure, main injection time, intake pressure, number of injection nozzle holes and combustion chamber shape. Eismarka et al. [7] found that fuel properties mainly affect parameters related to processes near the nozzle, such as ignition

delay, flame separation distance and air intake by the atomiser. A comparative assessment of gasoline and diesel engine emissions was performed in the study of Benajes et al. [8], and the results show that the dual-mode fuel concept has the potential for implementation in vehicles. In Millo et al. [10], the geometry of the piston bottom of a diesel engine was optimised, which contributed to the improvement of wall flame development, better mixing of air with fuel, and reduction of soot emissions.

As we can see from the researches discussed above, scientists solve the problem of reducing the toxicity of a diesel engine by making changes to the design of parts of the power system, which is quite complicated and expensive.

Scientists [11–15] have also studied the advantages and disadvantages of biodiesel fuel and its effect on exhaust gas toxicity and engine performance.

Thus, in the studies of Tuan Hoang [11, 12], to improve the mixing process and reduce engine toxicity, biodiesel fuel was preheated to 105°C to achieve similarities in some physical properties and atomisation parameters compared to diesel fuel, but emissions did not decrease. Further, the effect of biodiesel on engine performance and emissions depending on the oil source is established in various studies [13–15], which have used castor oil biodiesel (CAB), coconut oil biodiesel (COB), waste cooking oil (WCB) and soybean oil biodiesel (SME).

As we can see from previous studies [11–15], the quality of fuel mixing in engine cylinders, as well as its economy and environmental friendliness, largely depends on the type

and quality of fuel, and biodiesel fuel B100 based on rapeseed oil (RME) was not studied in these researches.

There are also other studies in the literature [16–30] that are devoted to discussion of issues pertaining to the influence of mixing quality on heat generation processes in diesel engines.

In Jo et al. [16], the effect of injection pressure, nozzle hole diameter and oxygen concentration was investigated. The results show that the jet and the separation length at the 30° jet angle were smaller than at the 45° jet angle, regardless of the injection conditions and oxygen concentration. The development of innovative designs of the diesel piston chamber by Millo et al. [10] and Piano et al. [17] demonstrated a significant improvement in the development of the wall flame, which led to a decrease in fuel consumption and soot emissions from the engine. Jena et al. [18] found that fuel properties significantly affect engine combustion characteristics. In Sevostyanov et al. [19], new aspects of the global problem are considered, including that of increasing the efficiency of diesel engines during the time of their operation in partial and transient modes. The research made it possible to reveal the physical nature of complex hydrodynamic phenomena in diesel fuel equipment, which causes the appearance of intercycle instability of fuel supply in the working process of individual cylinders. In Li et al. [20], the opposed-piston two-stroke diesel engine developed in Abani et al. [21] was investigated. To solve the problems of non-uniformity of mixing and economy, a combustion system with lateral swirl is proposed in this work. Additionally, combustion parameters were optimised using sensitivity analysis and parameter normalisation methods.

In Huo et al. [22], a comprehensive study of the effect of piston design on scavenging and combustion in a two-stroke engine was carried out, and the results show how an optimised combustion chamber design improves combustion and achieves a balance between scavenging and combustion, as well as piston temperature control.

Yamauchi et al. [23] and Fuyuto et al. [24] found that the return flow of hot burnt gas surrounding the diesel flame is one of the factors reducing the separation length, that is, the distance from the nozzle exit to which the flame spreads. To visualise the phenomena occurring in the combustion chamber of the engine, Pastor et al. [25] propose the use of optical designs of engines.

Studies of fuel atomisation in the combustion chamber and its mixing with air are carried out in the literature [26–30]. Thus, in Yaqing Bo et al. [26], it was established that the influence of injection pressure on ignition at low temperatures is not systematic. Increasing the fuel temperature from 313 K to 353 K [27] affected atomisation, while increasing temperature also increased the spray cone angle and spray width. On the other side, the decrease in spray cone angle and spray width was evident due to the decrease in fuel density and viscosity. In Yin et al. [28], the results showed that the penetration length of biodiesel liquid was longer than that of diesel under the same injection conditions.

In the study of Raghu and Nallusamy [29], the characteristics of biodiesel fuel atomisation in the combustion chamber were optimised according to three factors: fuel injection pressure, fuel temperature and fuel type. According to the results, it is proved that due to the optimisation of these parameters, it is possible to achieve optimal conditions of heat release.

Yu et al. [30] investigated the internal flow in the nozzle and the macroscopic characteristics of diesel and biodiesel spraying using a proven numerical model and the scattering method. The results show that the mass flow rate of diesel is higher than that of biodiesel.

As can be inferred from the literature [16–30], the issue of the influence of mixing quality on heat generation processes in diesel engines has not been studied adequately, and the influence of biodiesel based on RME has not been studied.

Researches are available in the literature that examine the feasibility of a diesel engine running on hydrogenated vegetable oil (HVO) [31–33] and pure vegetable oil (PVO) [34, 35]. According to the results obtained [31–33], there was an increase in NOx and a decrease in solid particles, soot and carbon oxides in the emissions. According to the results of researches conducted by Espadafor et al. [34] and Chiaramonti and Prussi [35], a reduction in emissions of harmful substances, including SOx, was observed, which characterises this fuel as a good substitute for commercial diesel fuel. However, the various studies conducted in the relevant literature [31–35] do not reveal the process of mixture formation and heat release, which accordingly forms the basis of our research.

So, based on the results of the review of literary sources, we found that the process of mixture and heat formation and emissions of harmful components are affected by such factors as fuel spray pressure, fuel spray angle, the number of nozzle holes and the content of hydrogen and oxygen in the fuel. Given that the influence of biodiesel based on RME for these processes is poorly studied, this line of research is taken up in the present work.

2. MATERIALS AND METHODS

2.1. Methodology for modelling mixture formation in diesel engines

To conduct studies of the work process in the engine, when using RME B100 biodiesel fuel, there is a need to use methods of system analysis and comparison. System analysis makes it possible to analyse, using objective criteria of comparative efficiency, the influence of factors operating in the working volume of the engine on the engine's performance.

The method of comparing the influence of factors such as the fractional composition of the fuel, cetane number, auto-ignition delay period, density, viscosity, calorific value, etc. on work processes in internal combustion engines allows us to make assumptions about the validity of the accepted assumptions. However, based only on the data of such a comparison, it is impossible to unequivocally state that the same factor will have the same effect on the processes in the internal combustion engine, both when using standard fuels and when using alternative analogues. This follows from the fact that there are significant differences in the flow of work processes in internal combustion engines that use only base fuel or fuel with a variable fractional composition.

Analysis of the problems associated with the use of biodiesel fuel in automobile internal combustion engines showed that the efficiency of engine operation depends on the following:

- the ratio between low-boiling, medium and heavy fuel fractions, which significantly affects the nature of the working process in the cylinders;
- the relationship between the fuel supply parameters and gas distribution phases of the internal combustion engine;
- redistribution of the components of the heat balance due to a change in the characteristics of the heat supply;
- the nature and law of heat transfer in the thermodynamic cycle of an internal combustion engine operating on biodiesel fuel.

The method of direct analogy between the processes in an internal combustion engine operating on standard fuels with the working processes in an internal combustion engine in the case of using biodiesel fuel makes it possible to find such solutions that allow us to ensure acceptable characteristics of heat release, as well as preserve or reduce the thermal stress of the elements of the internal combustion engine, which will improve environmental indicators.

The method of physical modelling of work processes in internal combustion engines using biodiesel fuel will not only allow the determination of the adequacy of the mathematical model and the validity of the assumptions made in the work but also enable the efficiency, fuel economy, reliability and durability of the engine to be ensured.

Mathematical modelling of the working process in an internal combustion engine in the case of using biodiesel fuel will allow us to determine the nature of the flow processes in the engine cylinders, to determine the influence of fuel parameters on the nature of the working process and the thermodynamic efficiency of the engine as a whole, and to develop methods for calculating the working cycle of the engine.

In the implementation of the mathematical model, a modified Euler method was used, which has satisfactory convergence and gives fairly accurate results.

During the development of the research methodology of the work process in diesel engines using biodiesel fuel, the following areas were highlighted:

- analysis of the problem associated with the use of biodiesel fuel in diesel engines, as well as analysis of factors affecting the work process;
- establishment of the influence of biodiesel fuel on mixture formation in internal combustion engines using mathematical modelling;
- proposal of ways to improve the work process in the internal combustion engine when using biodiesel fuel.

When using the original system of equations, generally accepted assumptions are made: about the homogeneity of the thermodynamic system, about the validity of the Mendeleev-Clapeyron equation of state, and about the dependence of the properties of the working body on composition and temperature.

The main difficulty in calculating the work processes that take place in an internal combustion engine cylinder is the determination of the dynamics of heat release $dx/dFi = F(\varphi)$ for calculating the amount of added heat at each calculation step:

$$Q_x = \xi_a \cdot q_c \cdot H_u \cdot \frac{dx}{dFi} \cdot \Delta Fi, \quad (1)$$

where H_u represents the lower heat of fuel combustion, ΔFi the calculated time step and ξ_a the factor accounting for heat loss due to incomplete combustion of fuel.

Nowadays, the Wiebe formula is widely used to calculate the rate of heat release, dx/dFi . However, its use for calculating working processes in diesel engines can be justified only if the fuel supply parameters will not change in the study, since the formula does not consider several determining physical processes. Wiebe's method is quite suitable for calculating the combustion process in gasoline and gas internal combustion engines.

The theoretically necessary amount of air for the combustion of 1 kg of fuel is determined from the equation of the combustion reactions of the elemental composition of the fuel:

$$l_0 = \frac{m_{air}}{0.21} \cdot \left(\frac{C}{12} + \frac{H}{4} + \frac{S}{32} - \frac{O}{32} \right), \quad (2)$$

where $m_{air} = 28.9$ is the molecular weight of air, and C, H, S and O represent the elementary mass composition of 1 kg of fuel.

We have implemented a modelling technique based on the works of Professor N.F. Razleitseva, which was later refined by A.S. Kuleshov. This method, with sufficient speed, allows consideration of the design features of the fuel equipment, the nature of injection, and the dynamics of the development of fuel jets, including the interaction of their products with walls of arbitrary shape and with each other.

In the refined model of heat release, as well as in the simplified one, four periods are distinguished, which differ in physical and chemical features and factors limiting the speed of the process:

- the self-ignition delay period;
- the outbreak start period;
- the period of controlled combustion in the fuel supply area after the flash;
- the period of diffusion combustion after the end of the fuel supply.

A model is conceptually described below, which additionally considers several significant factors, including the distribution of part of the fuel on the walls of the chamber in the piston, on the walls of the cylinder cover and on the cylinder mirror, and the conditions of fuel evaporation under the conditions of specific temperatures of these walls. Additionally, the model considers the influence of the tangential vortex, both on the free jet and on the wall flow formed by it. The conditions of the collision of a deformed jet vortex with a wall of arbitrary shape and the interaction of the wall flows of neighbouring jets with each other are considered.

The calculation of mixture formation and combustion is carried out in increments of $0.2^\circ \dots 1^\circ$ rotation of the crankshaft.

The average fuel flow rate from the injector nozzle is given as the following:

$$U_{0m} = \frac{24 \cdot g_c \cdot n}{0.75 \cdot \rho_f \cdot d_c \cdot i_c \cdot \varphi_{di}}, \quad (3)$$

where g_c indicates the cyclic fuel supply, n the crankshaft rotation frequency, ρ_f the fuel density, d_c and i_c the diameter and number of sprayer nozzles, respectively, and φ_{di} the duration of injection.

The instantaneous flow rate of fuel from the nozzle atomiser $U_0 = U_{0m} \cdot d\sigma/d\varphi$, where $d\sigma/d\varphi$ represents the dimensionless differential characteristic of injection.

The criterion M can be expressed as:

$$M = \mu_f^2 / (d_c \cdot \rho_f \cdot \sigma_f), \quad (4)$$

where μ_f represents the coefficient of dynamic viscosity of fuel at 323 K, and σ_f the coefficient of surface tension of fuel at 323 K.

The Weber criterion can be expressed as:

$$W_e = U_{0m}^2 \cdot \rho_f \cdot d_c / \sigma_f. \quad (5)$$

The criterion E can be expressed as:

$$E = \tau_s^2 \cdot \sigma_f / (\rho_f \cdot d_c^2), \quad (6)$$

where τ_s represents the time from the start of injection.

The simplex can be expressed as:

$$\rho = \rho_{air} / \rho_m, \quad (7)$$

where ρ_{air} represents air density at the end of the compression stroke.

The average surface diameter of droplets (Sauter diameter), in micrometre, is given as:

$$d_{32} = 10^6 \cdot E_{32} \cdot d_c \cdot M^{0.0733} / (\rho \cdot W_e)^{0.266} \quad (8)$$

where E32 indicates the empirical coefficient.

According to the model described above, in the main area of the jet development, each elementary portion of injected fuel moves in the axial core of the jet up to its top, where this portion is pushed to the periphery of the jet, decelerates sharply until the initial speed is completely lost, and fills the shell of the jet. Part of the mass of the elementary portion of the fuel is dispersed in the shell of the jet along the path of movement to the front.

2.2. Calculation scheme of the development of the fuel jet in the wall zone

The scheme of the development of the jet in the wall zone is presented in Fig. 1. During the impact of the front of the jet on the wall, a cone-shaped condensed fuel-gas layer (7) is formed on it within the spot, formed by the intersection of the cone of the jet with the surface of the wall. After the rapid formation of the jet front on the wall, the fuel will begin to spread beyond the initial spot. The high-speed axial flow of the jet, hitting the wall, compacts the wall layer and pushes its boundaries, and part of the flow moves above this layer to its periphery. The shape of the wall spot and the speed of its spreading in different directions depend on the angle of the jet meeting the wall and the influence of air turbulence.

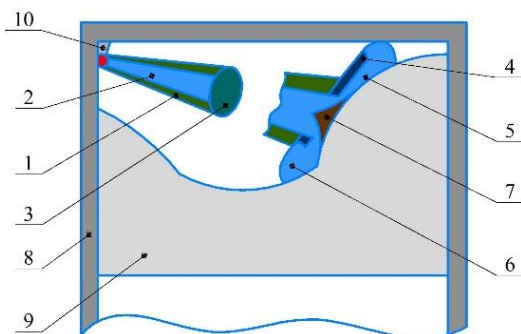

Fig. 1. Calculation scheme of the fuel jet of one injector hole: (1) rarefied shell of the jet; (2) compacted axial core; (3) compacted front; (4) rarefied PP shell; (5) compacted PP core; (6) the front line of the PP; (7) cone-shaped axial core PP; (8) cylinder; (9) piston; (10) nozzle

The advance of the fuel along the wall slows down compared to the free development of the jet due to the friction of the flow against the wall, the dissipation of the kinetic energy of the jet with drops reflected from the wall, etc. Additionally, the movement of the wall flow is affected by the air vortex in the combustion chamber, the intensity of which is given by the vortex number H.

The wall flow is heterogeneous in structure, density and temperature, which complicates the calculation of fuel evaporation. Therefore, it is advisable to distinguish three characteristic zones with averaged heat and mass transfer rates in the wall flow, as well as in the free jet.

The first zone is the cone formation of the axial core (7) on the wall, which is formed when the jet front is placed on the wall. In the future, the composition of this core would be continuously

updated due to new masses of fuel flying up to the wall. However, the total proportion of fuel in it changes little during the injection process.

The second zone is the wall layer of fuel, spreading beyond the initial spot (5). It can be considered as an analogue of an axial core in a free jet (2) in the main area of its development.

The third zone is a rarefied shell (4) above the wall layer, where part of the fuel slows down in the front (6) of the wall flow passes.

When the fuel spreads along the wall, and it spreads in all directions, the wall flow, which is also deformed by the vortex, may cross a characteristic boundary that separates zones with different conditions of fuel evaporation and combustion, for example, the transition from the side inclined to the horizontal surface of the bottom of the piston, the surface cylinder mirrors, etc. It is also possible to close the wall flow of neighbouring jets. In all these cases, the mass of fuel that has crossed the border is found from the solution of the geometric problem of the intersection of the oval formed by spots from the wall fuel flows.

If the calculated height of the front of the wall flow on the piston crest is greater than the height above the piston gap, then part of the fuel from the shell and core of the wall flow pops onto the cylinder head.

The study of the evaporation of atomised fuel in the combustion chamber and on the walls, as well as the calculation of the dynamics of heat release on different types of diesel fuel, is carried out using mathematical modelling. Heat supply is carried out according to a mixed scheme (Trinkler–Sabot cycle).

3. RESULTS AND DISCUSSION

3.1. Modelling of mixture and heat generation parameters in diesel engines during the use of diesel fuel

For modelling, we choose the DD15 engine of the Sandvik LH514 loader, whose brief characteristics are given in Tab. 1, using the Diesel-RK software complex.

The reference indicator for comparison will be the parameters obtained for the selected DD15 engine in the process of using commercial diesel fuel at full loads ($n = 1,800$ rpm).

According to the generally accepted description of the fuel jet (Fig. 1), it has a cone-shaped appearance and is denser in its central part than on the periphery. When the jet of fuel is evenly filled with drops, then on the image it is depicted in approximately one shade, or vice versa.

Tab. 1. Brief technical characteristics of the DD15 engine

Parameter name	Units	Parameter value
Number of cylinders	-	V8
Cylinder diameter	mm	130
Piston stroke	mm	139
Number of nozzle holes	-	3
Torque	N·m	1,559–1,830 (1,200 rpm.)
Working volume	l	11.1
Engine power	kW	246–272 (1,800–2,100 RMP)
Application	-	Mining and automotive equipment

Fig. 2 shows the results of studies of diesel atomisation parameters that comply with DSTU 7687:2015 for the DD15 engine. According to the results of these studies (Fig. 2), the main proportion of fuel, 0.71, is located in the shell of the jet, which contributes to better mixing of fuel with air. In the core of the wall, there is 0.15 of fuel, which will spread over the walls and mix poorly with air.

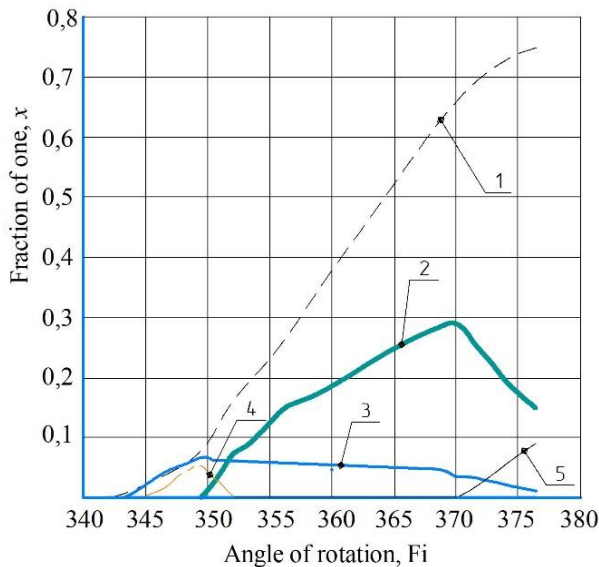

Fig. 2. Distribution of fuel by the spray torch zones of the DD15 engine of the Sandvik LH514 loader: (1) the proportion of fuel in the jet envelope; (2) the proportion of fuel in the wall core; (3) the proportion of fuel in the jet core; (4) the proportion of fuel in the front of the free jet; (5) the proportion of fuel in the intersection zones of wall flows

The rest of the fuel will be located in the core of the jet, the front of the free jet and the intersection zones of the wall flows, and will partially participate in the mixture formation and contribute to the mixing of the fuel-air mixture.

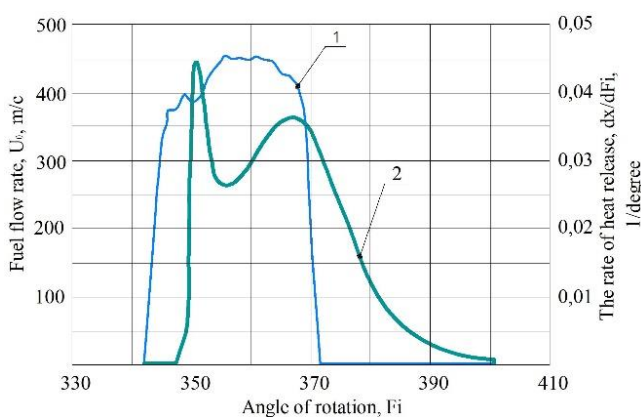

Fig. 3. Dependence of fuel flow rate U_0 and heat release dx/dFi on the angle of rotation of the crankshaft of the DD15 engine of the Sandvik LH514 loader: (1) fuel flow rate; (2) rate of heat release

Fig. 3 graphically displays the dependence of the fuel flow rate and heat release parameters (U_0 and dx/dFi , respectively) on the angle of rotation of the crankshaft for the DD15 engine of the Sandvik LH514 loader. As can be seen, the speed of fuel flow and heat release occurs instantaneously in a jump-like manner during

$5^\circ-7^\circ$ of rotation of the crankshaft, which positively affects the power and economy of the engine.

The main part of heat release (Fig. 4) occurs at the angle of rotation of the crankshaft of $20^\circ-25^\circ$, which is related to the previous graph since the speed of fuel flow and heat release occurs at this moment.

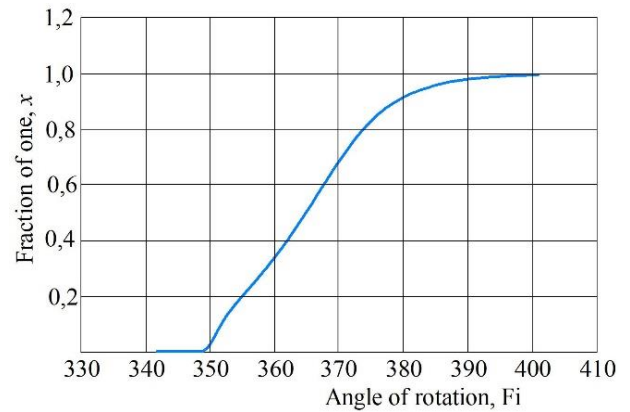

Fig. 4. Dependence of the share of heat release x on the angle of rotation of the crankshaft of the DD15 engine of the Sandvik LH514 loader

3.2. Modelling of mixture and heat generation in diesel engines during the use of biodiesel fuel

In the process of using RME B100 biodiesel, the characteristics of which are shown in Tab. 2, several indicators were obtained, as presented in Figs. 5–7.

However, considering the external characteristics of fuel jet spraying, the analysis of the obtained images showed that the use of RME B100 biodiesel leads to the following consequences:

- an increase in the average diameter of fuel drops;
- an increase in the range of the jet together with a decrease in its width;
- the assumption of a conical shape by the contour of the torch;
- the observation of an aggravation at its peak, from which it can be assumed that there is, to some extent, an over-enrichment of the jet's core; and
- a decrease in the opening angle of the torch.

Tab. 2. Basic physical and chemical parameters of diesel fuel according to DSTU 7688:2015 and RME B100 biodiesel fuel

Indicator name	Units	Value for diesel fuel	Value for RME B100
Chemical composition:			
C	%	87	77
H		12.6	12.1
O		0.4	10.9
Sulphur content	%	0.001	0.0015
Lower heat of combustion	MJ/kg	42.5	39.45
Cetane number	-	51	54.4
Density at a temperature of 323 K	kg/m ³	820–845	874
Saturated vapour pressure at a temperature of 481 K	bar	-	0.001
Molecular weight	kg/kmol	-	296

All these listed factors lead to a worse distribution of fuel in the zones of the spray torch, as shown in Fig. 5. Only 63% of the fuel is in the jet shell, which leads to poor mixing of fuel with air. In the core of the wall, there is 13% of the fuel, which will spread over the walls and mix poorly with air.

The remaining 24% of the fuel will be in the core of the jet, the front of the free jet and the intersection zones of the wall flows, and will partially participate in the mixture formation.

Fig. 6 graphically displays the dependence of the fuel flow rate and heat release parameters (U_0 and $dx/d\Phi$, respectively) on the angle of rotation of the crankshaft for the DD15 engine of the Sandvik LH514 loader in the process of using the RME B100.

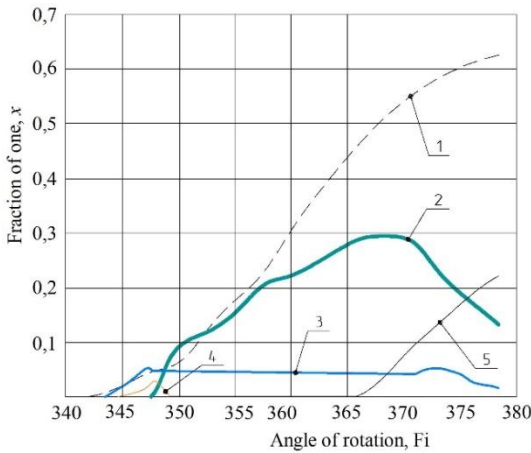

Fig. 5. Distribution of fuel in the zones of the spray torch during the operation of the DD15 engine of the Sandvik LH514 loader: (1) the proportion of fuel in the jet envelope; (2) the proportion of fuel in the wall core; (3) the proportion of fuel in the jet core; (4) the proportion of fuel in the front of the free jet; (5) the proportion of fuel in the intersection zones of wall flows

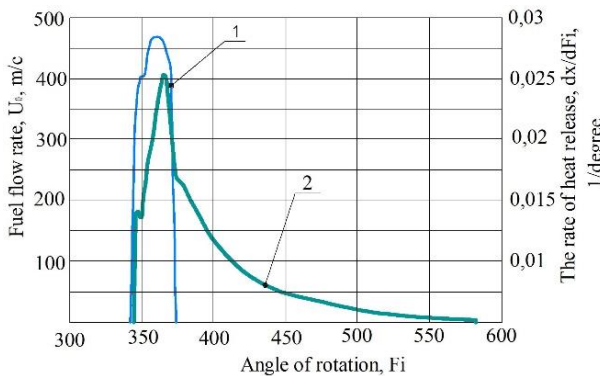

Fig. 6. Dependence of the rate of heat release $dx/d\Phi$ and fuel leakage U_0 on the angle of rotation of the crankshaft during the operation of the DD15 engine of the Sandvik LH514 loader on RME B100 biodiesel fuel: (1) fuel flow rate; (2) rate of heat release

As can be seen from Fig. 6, the speed of fuel flow and heat release occurs with a delay, by $8^\circ-10^\circ$ of rotation of the crankshaft, which will lead to an increase in fuel consumption and a decrease in engine power.

The main share of heat release of 80% (Fig. 7) occurs at the angle of rotation of the crankshaft of 102° relative to the bottom dead centre, which is related to the previous graph, since the speed of the fuel flow and release decreases.

We also modelled emissions of NO_2 and soot from the DD15 engine of the Sandvik LH514 loader in the process of using diesel fuel and RME B100 biodiesel (Fig. 8).

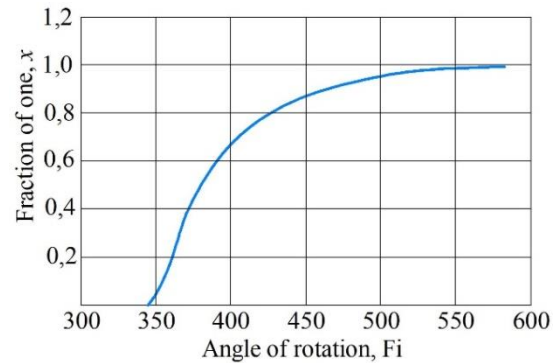

Fig. 7. Dependence of the share of heat release x on the angle of rotation of the crankshaft during the operation of the DD15 engine of the Sandvik LH514 loader on RME B100 biodiesel fuel

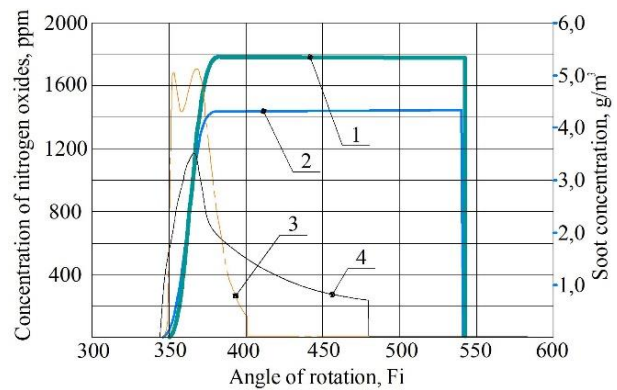

Fig. 8. Emissions of nitrogen oxides and soot from the DD15 engine of the Sandvik LH514 loader when running on diesel and RME B100 biodiesel: NO_2 emissions (1) when using diesel fuel; (2) when using RME B100 biodiesel fuel; soot emissions (3) when using diesel fuel; (4) when using RME B100 biodiesel

Based on the simulation results demonstrated in Fig. 8, we may infer that we have managed, in the process of using RME B100 biodiesel fuel, to improve the environmental performance of the diesel engine. A reduction in nitrogen dioxide emissions by 21.5% and a reduction in soot emissions by 34.5% were obtained. This can be explained by a decrease in the combustion temperature of biodiesel fuel by 7% and a decrease in the carbon content of the fuel by 11.5%.

3. CONCLUSION

In the process of modelling the mixture and heat generation parameters using the Diesel-RK software complex during the use of RME B100 biodiesel fuel on the DD15 engine of the Sandvik LH514 loader, the presence of the following phenomena was established: an increase in the average diameter of fuel drops; a recorded increase in the long-range of the jet together with a decrease in its width; the assumption of a conical shape by the contour of the torch; the observation of an aggravation at its peak, from which it can be assumed that there is, to some extent, an over-enrichment of the jet's core; and a decrease in the opening

angle of the torch. The listed factors lead to a worse distribution of fuel in the zones of the spray torch. Only 63% of the fuel is in the jet shell, which leads to poor mixing of fuel with air. In the core of the wall, there is 13% of the fuel, which will spread over the walls and mix poorly with air. The remaining 24% of the fuel will be in the core of the jet, the front of the free jet and the intersection zones of the wall flows, and will partially participate in the mixture formation.

The use of RME B100 biodiesel leads to a delay in heat release by 8°–10° of crankshaft rotation, which in turn leads to a slight increase in fuel consumption and a decrease in engine power by 7%.

According to the results of mowing in the process of using RME B100 biodiesel fuel, we determined a decrease in nitrogen dioxide emissions by 21.5% and a decrease in soot emissions by 34.5%. This will positively affect the environmental performance of the Sandvik LH514 loader, which is especially relevant in closed environments such as mines.

So, according to the results of studies of the operation of the DD15 engine of the Sandvik LH514 loader on commercial and RME B100 biodiesel fuel, it was established that the use of biodiesel fuel leads to a deterioration of the mixture, due to which heat generation is reduced and, as a result, fuel consumption increases and engine power decreases, but the aspect of environmental indicators constitutes the significant improvement demonstrated by the present work.

Accordingly, in consideration of these results, further research should be directed at improving mixture formation in the process of using biodiesel fuel, and one of the options for accomplishing this would be improving the geometric shapes of the combustion chamber.

Also, in the future, our work will be oriented towards the study of the performance indicators of the diesel engine in the process of using biodiesel fuel based on rapeseed oil.

REFERENCES

- Naoto H, Tatsuya K, Yuji M, Takashi S, Hiroshi K, Ishiyama T. Analysis of Mixture Formation Process in a Diesel Engine with Post Injection. SAE technical paper series. 2015. <https://doi.org/10.4271/2015-01-1836>
- O'Connor J, Musculus M. In-Cylinder Mechanisms of Soot Reduction by Close-Coupled Post-Injections as Revealed by Imaging of Soot Luminosity and Planar Laser-Induced Soot Incandescence in a Heavy-Duty Diesel Engine. SAE International Journal of Engines. 2014 Apr 1;7(2):673–93. DOI:10.4271/2014-01-1255
- Hessel R, Reitz RD, Musculus M, O'Connor J, Flowers D. A CFD Study of Post Injection Influences on Soot Formation and Oxidation under Diesel-Like Operating Conditions. SAE International Journal of Engines. 2014 Apr 1;7(2):694–713. DOI:10.4271/2014-01-1256
- O'Connor J, Musculus M. Effects of exhaust gas recirculation and load on soot in a heavy-duty optical diesel engine with close-coupled post injections for high-efficiency combustion phasing. International Journal of Engine Research. 2013 Jul 24;15(4):421–43. DOI:10.1177/1468087413488767
- O'Connor J, Musculus M. Post Injections for Soot Reduction in Diesel Engines: A Review of Current Understanding. SAE International Journal of Engines. 2013 Apr 8;6(1):400–21. DOI:10.4271/2013-01-0917
- Naoto H, Tatsuya K, Takashi S, Wang H, Ishiyama T. Smoke Reduction Effects by Post Injection for Various Injection Parameters and Combustion Chamber Shapes in a Diesel Engine. SAE technical paper series. 2014 Oct 13. DOI:10.4271/2014-01-2634
- Eismark J, Christensen M, Andersson M, Karlsson A, Denbratt I. Role of fuel properties and piston shape in influencing soot oxidation in heavy-duty low swirl diesel engine combustion. Fuel. 2019 Oct;254:115568. DOI: <https://doi.org/10.1016/j.fuel.2019.05.151>
- Benajes J, García A, Monsalve-Serrano J, Lago Sari R. Fuel consumption and engine-out emissions estimations of a light-duty engine running in dual-mode RCCI/CDC with different fuels and driving cycles. Energy. 2018 Aug;157:19–30. DOI:10.1016/j.energy.2018.05.144
- Rao L, Zhang Y, Kook S, Kim KS, Kweon CB. Morphology and internal structure of soot particles under the influence of jet–swirl and jet–jet interactions in a diesel combustion environment. Combustion and Flame. 2020 Apr;214:25–36. <https://doi.org/10.1016/j.combustflame.2019.12.017>
- Millo F, Piano A, Roggio S, Pastor JV, Micó C, Lewiski F, et al. Mixture formation and combustion process analysis of an innovative diesel piston bowl design through the synergetic application of numerical and optical techniques. February 2022, Fuel, Volume 309. <https://doi.org/10.1016/j.fuel.2021.122144>
- Hoang AT. Experimental study on spray and emission characteristics of a diesel engine fueled with preheated bio-oils and diesel fuel. Energy. 2019 Mar;171:795–808. <https://doi.org/10.1016/j.energy.2019.01.076>
- Hoang AT. Waste heat recovery from diesel engines based on Organic Rankine Cycle. Applied Energy. 2018 Dec;231:138–66. <https://doi.org/10.1016/j.apenergy.2018.09.022>
- Zareh P, Zare AA, Ghobadian B. Comparative assessment of performance and emission characteristics of castor, coconut and waste cooking based biodiesel as fuel in a diesel engine. Energy. 2017 Nov;139:883–94. <https://doi.org/10.1016/j.energy.2017.08.040>
- Rakopoulos DC, Rakopoulos CD, Giakoumis EG, Papagiannakis RG, Kyritsis DC. Influence of properties of various common bio-fuels on the combustion and emission characteristics of high-speed DI (direct injection) diesel engine: Vegetable oil, bio-diesel, ethanol, n-butanol, diethyl ether. Energy. 2014 Aug;73:354–66. <https://doi.org/10.1016/j.energy.2014.06.032>
- Mohamed Khaled Abdelrazek, Mohsen Mohamed Abdelaal, Ahmed Mustafa El-Nahas. Numerical simulation of a diesel engine performance powered by soybean biodiesel and diesel fuels. Beni-Suef University Journal of Basic and Applied Sciences. 2023 Jan 22;12(1). <https://doi.org/10.1186/s43088-023-00349-w>
- Jo H, Ishikawa T, Naoto Horibe, Hayashi J, Hiroshi Kawanabe, Ishiyama T. Effect of Jet-Jet Angle on Combustion Process of Diesel Spray in an RCEM. SAE International Journal of Advances and Current Practices in Mobility. 2020 Sep 15;3(1):276–86. <https://doi.org/10.4271/2020-01-2058>
- Piano A, Roggio S, Millo F, García A, Micó C, Lewiski F, et al. Numerical and optical soot characterization through 2-color pyrometry technique for an innovative diesel piston bowl design. Fuel. 2023 Feb 1;333:126347–7. <https://doi.org/10.1016/j.fuel.2022.126347>
- Jena A, Akhilendra Pratap Singh, Avinash Kumar Ágarwal. Optical and computational investigations of the effect of Spray-Swirl interactions on autoignition and soot formation in a compression ignition engine fuelled by Diesel, dieseline and diesohol. Applied Energy. 2022 Oct 1;324:119677–7. <https://doi.org/10.1016/j.apenergy.2022.119677>
- Sevostyanov SM, Melnyk ME, Vakarenko SV. Research of inter-communication of serve of fuel and mixtureform with working process in diesels during work on partial modes. Modern problems and ways of their solution in science, transport, production and education. Sword. 2012 Dec 18-27:48-53.
- Yang W, Li F, Ma F, Xu J. Numerical analysis of mixing and combustion characteristics of a lateral swirl combustion system in OP2S diesel engines. Proceedings of the Institution of Mechanical Engineers, Part D: Journal of Automobile Engineering. 2022 Sep 16;095440702211218. <https://doi.org/10.1177/09544070221121874>

21. Neerav A, Nagar N, Zermeno R, Chiang M, Thomas I. Developing a 55% BTE Commercial Heavy-Duty Opposed-Piston Engine without a Waste Heat Recovery System. SAE technical paper series. 2017 Mar 28. <https://doi.org/10.4271/2017-01-0638>
22. Huo M, Huang Y, Hofbauer P. Piston Design Impact on the Scavenging and Combustion in an Opposed-Piston, Opposed-Cylinder (OPOC) Two-Stroke Engine. SAE technical paper series. 2015 Apr 14. <https://doi.org/10.4271/2015-01-1269>
23. Yamauchi J, Dong P, Nishida K, Ogata Y. Effects of Hole Diameter and Injection Pressure on Fuel Spray and Its Evaporation Characteristics of Multi-Hole Nozzle for Diesel Engine. 2017 Oct 8. DOI:10.4271/2017-01-2305
24. Fuyuto T, Hattori Y, Yamashita H, Toda N, Mashida M. Set-off length reduction by backward flow of hot burned gas surrounding high-pressure diesel spray flame from multi-hole nozzle. International Journal of Engine Research. 2016 Jul 28;18(3):173–94. DOI:10.1177/1468087416640429.
25. Pastor J, Olmeda P, Javier Rodríguez Martín, Lewiski F. Methodology for Optical Engine Characterization by Means of the Combination of Experimental and Modeling Techniques. Applied sciences. 2018 Dec 11;8(12):2571–1. DOI:10.3390/app8122571
26. Bo Y, Liu F, Wu H, Li H, Shi Z. A numerical investigation of injection pressure effects on wall-impinging ignition at low-temperatures for heavy-duty diesel engine. Applied Thermal Engineering. 2021 Feb 1;184:116366–6. <https://doi.org/10.1016/j.applthermaleng.2020.116366>
27. Srinivasan R, Raja G, Nallusamy N, Raghu P. Experimental study of mixture formation in biodiesel spray with preheated fuel International Journal of Applied Engineering Research. 2015 Mar; 10;19; 13687-13691.
28. Yin B, Ye Z, Jia H, Yu S, Deng WQ. Experimental Study on the Penetration of Diesel and Biodiesel Spray Liquid Emerging from an Equilateral Triangular Orifice under Evaporative Conditions. Journal of Thermal Science. 2022 Jan 22;31(5):1565–74. <https://doi.org/10.1007/s11630-022-1529-5>
29. Raghu P, Nallusamy N, Spray characteristics of biodiesel fuel in constant volume chamber using multi-response optimization technique. Journal of Thermal Science, 2016, 25(6):581–588.
30. Yu S, Yin B, Jia H, Wen S, Li X, Yu J. Theoretical and experimental comparison of internal flow and spray characteristics between diesel and biodiesel. Fuel. 2017 Nov 1;208:20–9. DOI:10.1016/j.fuel.2017.06.136
31. McCaffery C, Zhu H, Sabbir Ahmed CM, Canchola A, Chen JY, Li C, et al. Effects of hydrogenated vegetable oil (HVO) and HVO/biodiesel blends on the physicochemical and toxicological properties of emissions from an off-road heavy-duty diesel engine. Fuel. 2022 Sep;323:124283. <https://doi.org/10.1016/j.fuel.2022.124283>
32. Aatola H, Larmi M, Sarjoavaara T, Mikkonen S. Hydrotreated Vegetable Oil (HVO) as a Renewable Diesel Fuel: Trade-off between NOx, Particulate Emission, and Fuel Consumption of a Heavy Duty Engine. SAE International Journal of Engines. 2008 Oct 6;1(1):1251–62. DOI:10.4271/2008-01-2500
33. Roque LFA, Berliini R, de Z, Coronado CJR, Pinto GM, Cintra AJA, et al. Experimental analysis and life cycle assessment of green diesel (HVO) in dual-fuel operation with bioethanol. 2023 Jan 1;389: 135989–9. <https://doi.org/10.1016/j.jclepro.2023.135989>
34. Jiménez Espadafor F, Torres García M, Becerra Villanueva J, Moreno Gutiérrez J. The viability of pure vegetable oil as an alternative fuel for large ships. Transportation Research Part D: Transport and Environment. 2009 Oct;14(7):461–9. <https://doi.org/10.1016/j.trd.2009.05.005>
35. Chiamonti D, Prussi M. Pure vegetable oil for energy and transport. International Journal of Oil, Gas and Coal Technology. 2009;2(2):186. DOI: 10.1504/IJOGCT.2009.024886

The present article originated as part of a research internship of Michal Bembenek at the Institute of Mechanical Engineering, Ivano-Frankivsk National Technical University of Oil and Gas, and Vasyl Melnyk at the Faculty of Mechanical Engineering and Robotics, AGH University of Science and Technology.

Michal Bembenek:  <https://orcid.org/0000-0002-7665-8058>

Vasyl Melnyk:  <https://orcid.org/0000-0002-5793-5486>

Yurii Mosora:  <https://orcid.org/0000-0002-3192-7146>



This work is licensed under the Creative Commons BY-NC-ND 4.0 license.