

Based on neural network adaptive linear quadratic regulator for inverter with voltage matching circuit

Łukasz Niewiara, Tomasz Tarczewski
Nicolaus Copernicus University
87-100 Toruń, ul. Grudziądzka 5, e-mail: lukniewiara@fizyka.umk.pl,
ttarczewski@fizyka.umk.pl

Lech M. Grzesiak
Warsaw University of Technology
00-661 Warszawa, ul. Koszykowa 75, e-mail: lmg@isep.pw.edu.pl

This paper describes a discrete adaptive linear quadratic regulator used to load current control in terms of variable DC voltage of inverter. Controller was designed by using linear quadratic optimization method. Adaptive LQR was used because of non-stationarity of the control system caused by Voltage Matching Circuit - VMC. Gain values of the adaptive controller were approximated by using an artificial neural network. The VMC was realized as an additional buck converter integrated with the main inverter. As the load of the 2-level inverter a 3-phase symmetric RL circuit was used. Simulation tests show the behavior of the load current regulation during DC bus voltage level step changes. The dependence between current RMS value and inverter DC bus voltage level was also shown. There were also made a comparison of the traditional 2-level inverter structure with the modified structure uses VMC. Simulation test was made by using Matlab Simulink and PLECS software.

KEYWORDS: adaptive linear-quadratic regulator, voltage matching circuit, artificial neural network, current ripple

1. Introduction

Rectangular shape of the of the converter output voltage produced by using PWM method deteriorates performance of the load operation due to current ripple as well as noise generation [1]. Current ripple generates undesirable noise. Reduction of the current ripple can be realized by using an additional passive LC filter between inverter and load [2] or by using multilevel inverters [3].

In this paper current ripple minimization is realized by using a 2-level voltage source inverter with an additional buck converter [4]. It was necessary to use an adaptive controller to realize current regulation process because Voltage Matching Circuit (VMC) introduces non-stationarity into the control system. A linear quadratic regulator has been used because of ability of control non-stationary systems [5]. The adaptation was realized by an artificial neural network because of

good approximation and control abilities [6]. The control behavior and quality is considered in a simulation study. The behavior of the current control loop is investigated during DC bus voltage value changes.

2. Mathematical model of the system

Proposed system topology consist a three-phase RL symmetric circuit fed by a 2-level source voltage inverter. An additional buck converter was introduced to the inverter structure, which serves as a voltage matching circuit (Fig. 2). The block diagram of considered system was shown in Fig. 1.

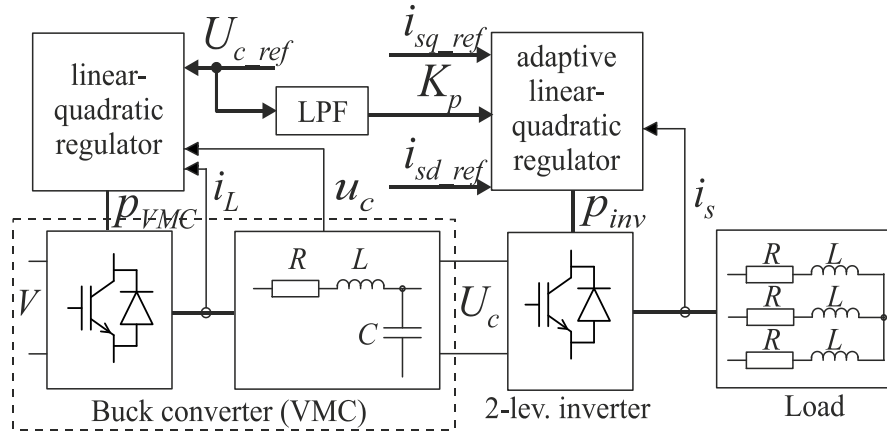

Fig. 1. Proposed control system block diagram

Mathematical model of the VMC is equal to a buck converter model with an LC filter on the output. The equation becomes a following form [4]:

$$\frac{dx_B}{dt} = A_B x_B + B_B u_B + E_B d_B \quad (1)$$

where:

$$x_B = \begin{bmatrix} i_L \\ u_c \end{bmatrix}, A_B = \begin{bmatrix} -\frac{R}{L} & -\frac{1}{L} \\ \frac{1}{C} & 0 \end{bmatrix}, B_B = \begin{bmatrix} \frac{K_{pp}}{L} \\ 0 \end{bmatrix}, E_B = \begin{bmatrix} 0 \\ -\frac{1}{C} \end{bmatrix},$$

$$u_B = u_{cc}, d_B = i_o$$

i_L – coil current, u_c – capacitor voltage, R – coil resistance, L – coil inductance, C – capacitor capacitance, K_{pp} – buck converter gain, u_{cc} – input voltage, i_o – load current. Dynamics of the VMC was approximated by using a proportional gain.

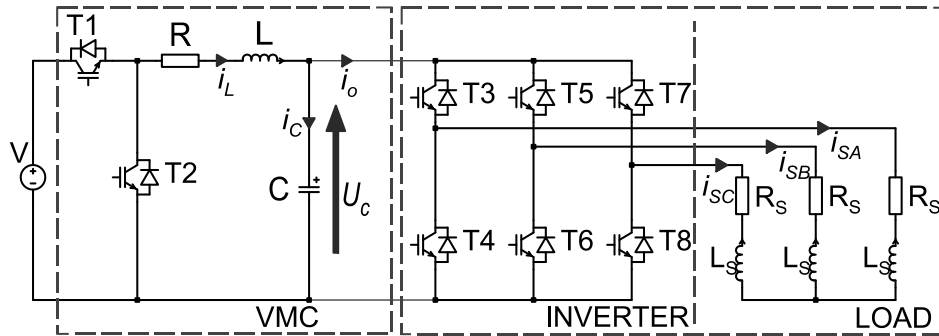

Fig. 2. Topology of the system

The mathematical model of the RL circuit was written in a orthogonal d, q coordinates system in state equation form:

$$\frac{dx_L}{dt} = A_L x_L + B_L u_L \quad (2)$$

where:

$$x_L = \begin{bmatrix} i_{sd} \\ i_{sq} \end{bmatrix}, A_L = \begin{bmatrix} -\frac{R}{L_s} & 0 \\ 0 & -\frac{R_s}{L_s} \end{bmatrix}, B_L = \begin{bmatrix} \frac{K_p}{L_s} & 0 \\ 0 & \frac{K_p}{L_s} \end{bmatrix}, u_L = \begin{bmatrix} u_{dc} \\ u_{qc} \end{bmatrix}$$

u_{dc}, u_{qc} – input voltage spade vector components, i_{dc}, i_{qc} – space vectors of current, R_s – load resistance, L_s – load inductance, K_p – variable inverter gain ($K_p = U_c/2$).

Note that the model of the load is non-stationary due variable inverter gain in matrix B_L due using VMC.

3. VMC controller structure

To realize the DC bus voltage control, there was used a discrete linear quadratic regulator. In order to determine the controller gain values, a linear-quadratic optimization method has been used. It was necessary to introduce an internal model of the reference signal to eliminate DC voltage steady-state error. The extended state equation takes the following form [7]:

$$\frac{dx_{BI}}{dt} = A_{BI} x_{BI} + B_{BI} u_{BI} + F_{BI} r_{BI} \quad (3)$$

where:

$$\mathbf{x}_{BI} = \begin{bmatrix} i_L \\ u_c \\ e_u \end{bmatrix}, \mathbf{A}_{BI} = \begin{bmatrix} -\frac{R}{L} & -\frac{1}{C} & 0 \\ \frac{1}{C} & 0 & 0 \\ 0 & 1 & 0 \end{bmatrix}, \mathbf{B}_{BI} = \begin{bmatrix} \frac{K_{pp}}{L} \\ 0 \\ 0 \end{bmatrix}, \mathbf{F}_{BI} = \begin{bmatrix} 0 \\ 0 \\ -1 \end{bmatrix},$$

$$u_{BI} = u_B, r_{BI} = u_{cref}$$

u_{cref} – reference value of the DC voltage. The third state variable (DC voltage error) is described by the following equation:

$$e_u(t) = \int_0^t [u_c(\tau) - u_{cref}(\tau)] d\tau \quad (4)$$

To calculate the gains of the discrete linear-quadratic regulator the Matlab's *lqrd* function was used. Following penalty matrices were determined:

$$\mathbf{Q}_{BI} = \begin{bmatrix} 1 \cdot 10^{-3} & 0 & 0 \\ 0 & 4 \cdot 10^{-3} & 0 \\ 0 & 0 & 3 \cdot 10^3 \end{bmatrix}, \mathbf{R}_{BI} = I \quad (5)$$

Values of the matrices were selected empirically to achieve the maximum permissible dynamics in the linear area of modulation. It was very important to ensure zero steady-state voltage error for load current step changes as well as the reference voltage changes.

4. Inverter controller structure

In order to realize the i_s current regulation a discrete linear quadratic regulator has been used. In case of a regulated DC bus voltage the mathematical plant model would be non-stationary. The current regulation in each axis can be considered independently, because in a symmetric RL circuit doesn't exist any correlation between the current in d and q axis in a orthogonal coordinates system. The extended state equation of the receiver with inverter is as follow [7]:

$$\frac{d\mathbf{x}_{LI}}{dt} = \mathbf{A}_{LI}\mathbf{x}_{LI} + \mathbf{B}_{LI}u_{LI} + \mathbf{F}_{LI}r_{LI} \quad (6)$$

where:

$$\mathbf{x}_{LI} = \begin{bmatrix} i_{sd|sq} \\ e_{isd|sq} \end{bmatrix}, \mathbf{A}_{LI} = \begin{bmatrix} -\frac{R_S}{L_S} & 0 \\ 1 & 0 \end{bmatrix}, \mathbf{B}_{LI} = \begin{bmatrix} \frac{K_p}{L_S} \\ 0 \end{bmatrix}, \mathbf{F}_{LI} = \begin{bmatrix} 0 \\ -1 \end{bmatrix}$$

$$u_{LI} = u_{sd|sq}, r_{LI} = i_{sd|sqref}$$

The variables e_{isd} and e_{isq} correspond to the integral of current error in d and q axis accordingly:

$$e_{isd|sq}(t) = \int_0^t [i_{sd|sq}(\tau) - i_{sdref|sqref}(\tau)] d\tau \quad (7)$$

where: i_{sdref}, i_{sqref} – reference value of the current in d and q axis. The input matrix B_{LI} is non-stationary because of the presence of variable gain K_p . In such a case it was necessary to create an adaptive discrete state controller. Matlab's *lqrd* function has been used to calculate the gain coefficients of the controller (Fig. 3).

To calculate the variable controller gain values the following penalty matrices has been used:

$$Q_{LI} = \begin{bmatrix} 1 \cdot 10^{-1} & 0 \\ 0 & 5 \cdot 10^4 \end{bmatrix}, \quad R_{LI} = 1 \cdot 10^{-3} \quad (8)$$

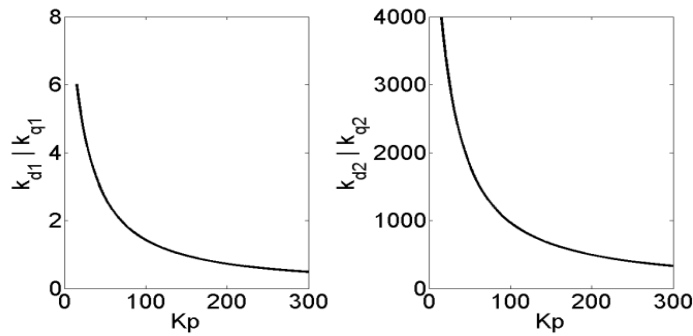

Fig. 3. Dependence between controller coefficients and inverter gain

Structure of the designed controller was shown below (Fig. 4). The neural network is used to determine controller gain coefficients depending on the VMC voltage level (inverter gain value).

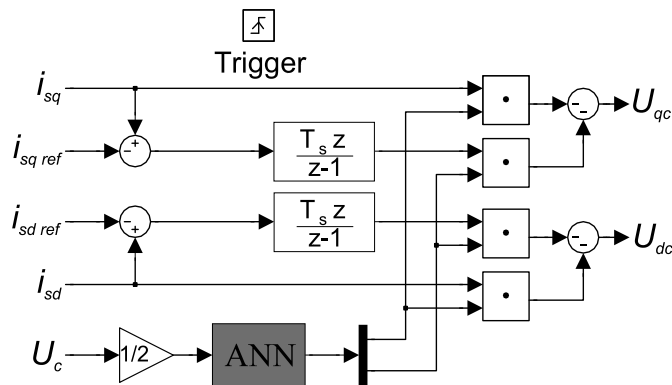

Fig. 4. Adaptive discrete linear quadratic regulator structure

5. Neural network structure

The non-linear dependences presented in Fig. 3 were approximated by using artificial neural network. The controller coefficients can be successfully approximated with an artificial neural network with 4 neurons in the first layer and 2 neurons in the output layer. The artificial neural network structure was shown below (Fig. 5). The mean square error was less than $1 \cdot 10^{-7}$ after 438 iterations.

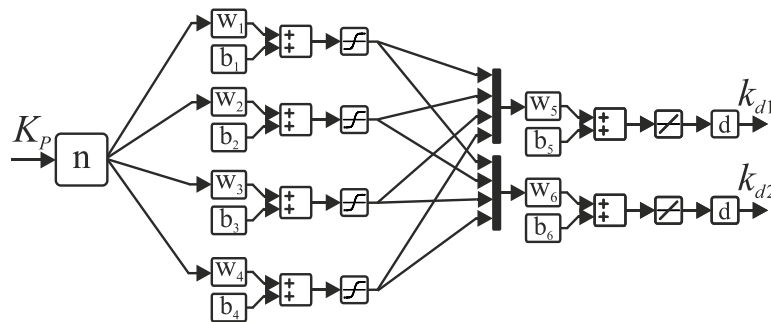

Fig. 5. Artificial Neural Network structure

6. Simulation results

The proposed adaptive regulation system of the 2 level inverter with VMC has been simulated in a Matlab/Simulink/PLECS environment (Fig. 6). The designed controllers and measurement units were implemented as triggered discrete subsystems. It was necessary to ensure proper generation of the control systems. Measure blocks are triggered by a synchronization signal in the midpoint of the PWM length to provide measurement of the average signal value. The switching frequency of the buck converter was set by $f_{s1} = 50$ kHz, while the voltage inverter switching frequency was set by $f_{s2} = 12$ kHz.

The simulations shows the behavior of the system in case of current step response during VMC voltage step changes (Fig. 7). The current error value in steady state is zero though DC voltage changes. The adaptation algorithm properly controls the load current.

The root mean square value of the load current error in steady-state was analyzed depending of the DC voltage. The considered RMS is given by equation below:

$$RMS_{e_{isd|sq}} = \sqrt{\frac{1}{t_2 - t_1} \int_{t_1}^{t_2} [i_{sdref|sqref}(t) - i_{sd|sq}(t)]^2 dt} \tag{9}$$

The dependence between inverter gain value and calculated RMS (9) value was shown in Fig. 8 and Fig. 9, where can see that dc voltage reduction reduces the average current ripple in both axes. Positive impact of the designed system is visible in different working conditions (i.e. reference current value and frequency).

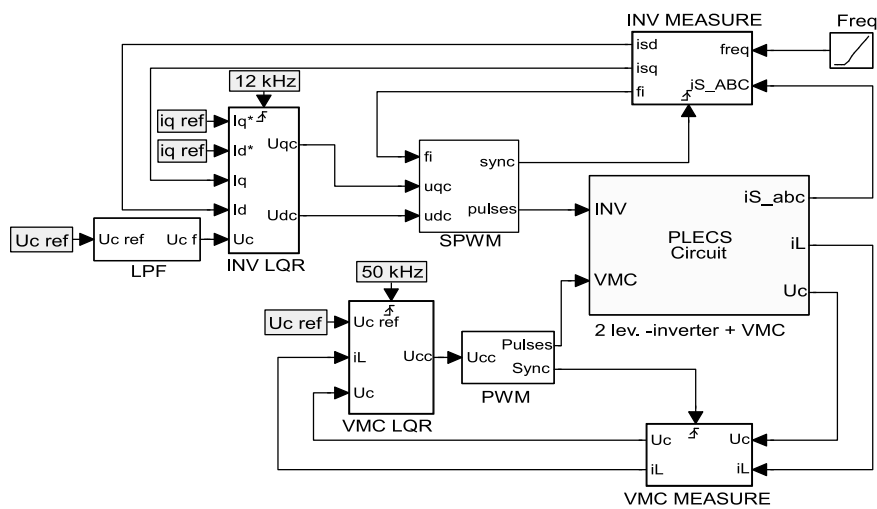

Fig. 6. Schematic diagram of the designed control system

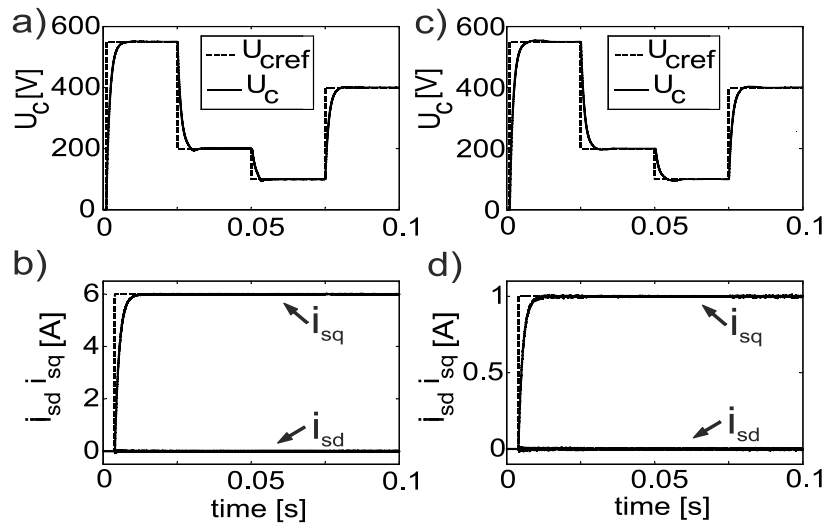

Fig. 7. Receiver current step response during VMC voltage changes

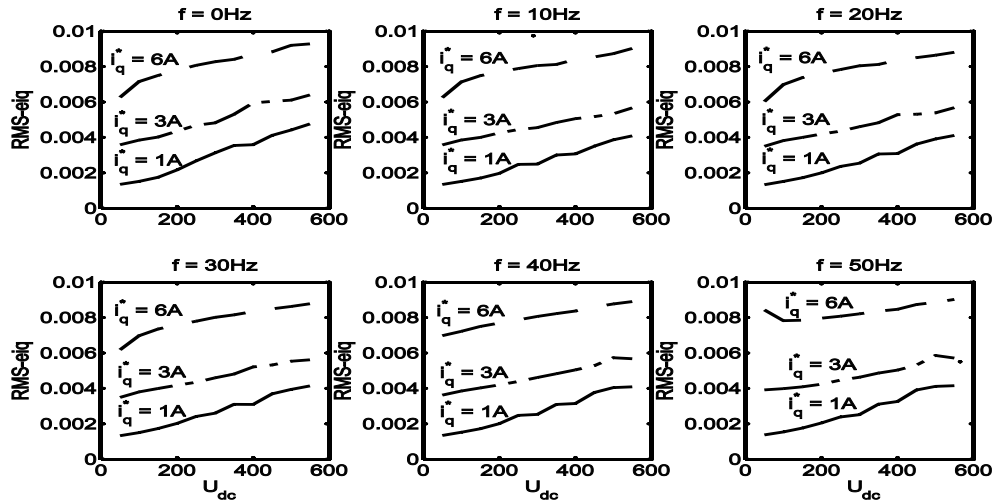

Fig. 8. RMS current error values in q axis

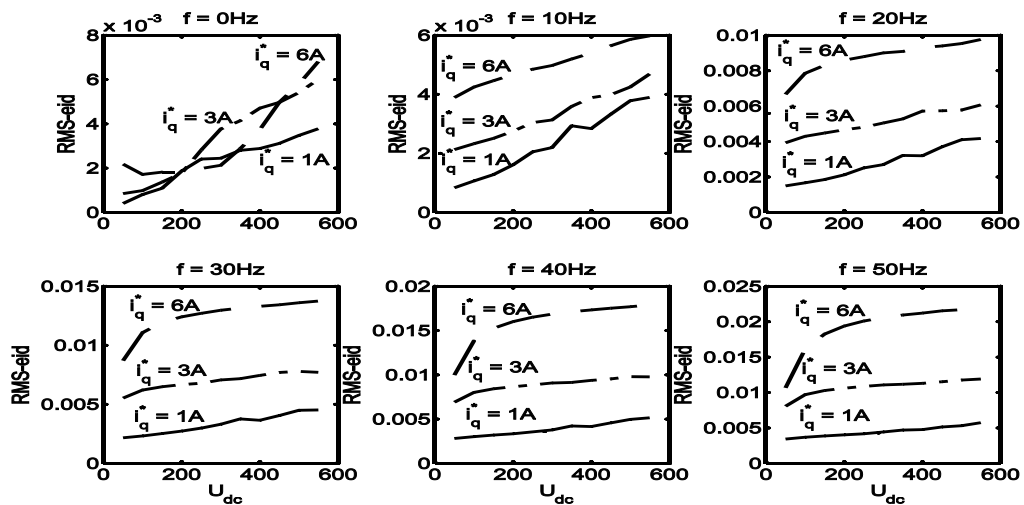

Fig. 9. RMS current error values in d axis

Comparison of the systems dynamics was shown Fig. 10 and Fig. 11. In the first row are the shown the DC – link voltage behavior. First column a traditional 2 level inverter structure, second column a 2 level inverter with additional VMC. The second row contains the current step response.

Analyzing Fig. 10 and Fig. 11 can be seen that the dynamics of compared systems is similar. The current step response for i_{qref} value of 1A are shown in Fig. 10.b (traditional 2-level topology) and Fig. 10d (2-level + VMC topology).

The current step response for i_{qref} value of 6A are shown in Fig. 11b (traditional 2-level topology) and Fig. 11d (2-level + VMC topology). Simulation results indicate proper operation of the proposed algorithm.

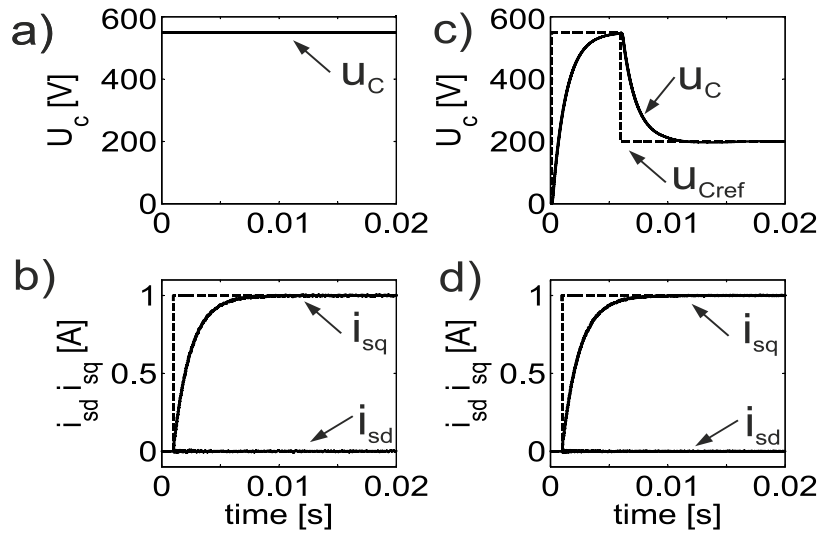

Fig. 10. Dynamics of traditional 2 level inverter and 2 level inverter with VMC – 1A

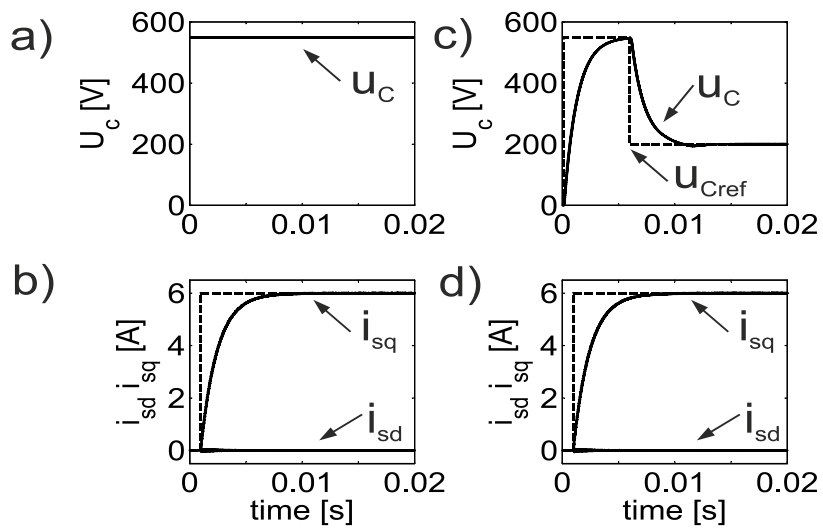

Fig. 11. Dynamics of traditional 2 level inverter and 2 level inverter with VMC – 6A

7. Conclusion

It was found that the neural network based adaptive linear quadratic regulator can be successfully used to control load current during DC voltage value changes. The artificial neural network approximate the non-linear dependences between controller coefficient and inverter gain. The adaptation algorithm properly controls the load current and the steady-state current error is equal zero. DC bus voltage changes don't affect the system response through proposed adaptation algorithm. The proposed system topology has a similar dynamics to traditional solution, which is the advantage of the proposed system.

Based on buck converter structure VMC was successfully introduced in order to precise control of the DC voltage value.

References

- [1] Gulez K., Adam A.A., Pastaci H., "Torque ripple and EMI noise minimization in PMSM using active filter topology and field-oriented control", IEEE Trans. on Ind. Electronics, vol. 55, no. 1, 2008, pp. 251–257.
- [2] Tarczewski T., Grzesiak L., Sterowanie od stanu serwonapędem z silnikiem PMSM zasilanym z przekształtnika o sinusoidalnym napięciu wyjściowym, Przegląd Elektrotechniczny, 88 (4b), 252- 258, 2012.
- [3] STEINKE, Juergen K. Use of an LC filter to achieve a motor-friendly performance of the PWM voltage source inverter. Energy Conversion, IEEE Transactions on, 1999, 14.3: 649-654.
- [4] Niewiara Ł., Tarczewski T., Grzesiak L. M., Trójfazowy mostkowy falownik napięcia o regulowanym napięciu obwodu pośredniczącego, SENE 2013.
- [5] Tarczewski T., Grzesiak L. M., "PMSM fed by 3-level NPC sinusoidal inverter with discrete state feedback controller," In: Proc. IEEE 15th European Conference on Power Electronics and Applications (EPE), 2013, pp.1–9.
- [6] Pajchrowski T., Zawirski K., Brock S., Application of neuro-fuzzy techniques to robust speed control of PMSM, Compel, 2007, 26.4: 1188-1203.
- [7] Ogata, K., Modern Control Engineering, Prentice-Hall, Upper Saddle River, NJ (2002).