

METHOD FOR EVALUATING DISCOMFORT GLARE BASED ON THE ANALYSIS OF A DIGITAL IMAGE OF AN ILLUMINATED INTERIOR

Urszula Joanna Błaszczak

Białystok University of Technology, Faculty of Electrical Engineering, Department of Optoelectronics and Light Technology, Wiejska 45 D, 15-351 Białystok, Poland (✉ u.blaszczak@pb.edu.pl), +48 85 746 9447

Abstract

The article proposes a method for measuring discomfort glare which uses numerical description of the phenomenon in the form of a digital luminance distribution map recorded on a CCD array. Essential procedures for determining partial quantities which are necessary for calculation of *UGR* index are discussed in detail, along with techniques for measuring position index and size of light sources, with regard to the parameters of the registering system and coordinates of the images of the sources on the array.

Keywords: discomfort glare, measurement, lighting, image analysis.

© 2013 Polish Academy of Sciences. All rights reserved

1. Introduction

The human visual system, which is a complex structure for detection and processing of light, can work effectively at defined values of illuminance and luminance of objects within the field of view. An essential role in the improvement of conditions for visual tasks is played by artificial lighting by means of which the intensity level of indoor illumination level can be controlled. Very often, generating the desired luminous flux, especially at high levels of light intensity, requires multiple light sources. For this reason, in the field of view of a person remaining in thus lit environment there are areas of diversified luminance. The human eye is adapted to such conditions, as it is capable of processing information within the luminance bracket of 15 orders of magnitude [1]. Be that as it may, the adaptability of the human visual system is ultimately limited, and even preserving lighting levels recommended for specific tasks does not prevent from occurring phenomena which lower the visual comfort. One of such adverse phenomena is glare, defined as visual condition under which a feeling of discomfort and/or reduction of perceptive abilities takes place [2]. Other definitions of glare are also in widespread use; for example, it is defined as “a course of visual process accompanied by sensation of discomfort or reducing ability to recognize object...” [3] or as “a sensation caused by bright areas in the field of view” [4]. But despite the definitional differences, these are always the same factors and dependencies which affect the occurrence of glare.

Three basic kinds of glare can be distinguished: disturbing glare, discomfort glare and disability glare. Among these, discomfort glare, often referred to as “psychological”, is of particular interest, because it constitutes a serious source of hazard for psychophysical health of the exposed person. Specifically, it triggers sensations of displeasure, uneasiness, irritation, as well as attention disorders. That is why keeping discomfort glare under control becomes one of the essential factors in maintaining proper interior lighting quality. There are no currently known methods for arbitrary evaluation of discomfort glare, its values being estimated relying on datasheets and prescriptive requirements concerning specific room

geometry [2, 4]. Some guidelines have been provided by the International Commission on Illumination (CIE) on quantitative description of the phenomenon of glare along with a relevant numerical scale measuring the degree of discomfort felt by a person under given lighting conditions. The guidelines have been drawn up in effect of many years of psychophysical research, and they suggest that in order to evaluate discomfort glare it is necessary to determine background luminance, along with luminance of light sources present in the field of vision, their size and placement. Apart from that, the procedures for evaluation of discomfort glare developed partly on the basis of the guidelines are extremely arduous, in terms of both data collection and adapting the data to the form of the defined synthetic indicators. Insofar as the latter part of the task may be considerably facilitated by dedicated numerical algorithms, the acquisition of quantitative data – considering the available measuring instruments – is a hugely laborious and time-consuming duty, especially facing the fact that research concerning the analyzed interior space (i.e. room) should be repeated for all spots inside that are potentially suitable for people performing visual tasks. This situation results from the lack of any objective indicator or method for evaluation of discomfort glare.

In the fifties of the past century research commenced on quantitative description of discomfort glare, and ever since many hypotheses trying to explain the origins of this phenomenon have appeared [7, 8, 9, 10, 11, 12, 13, 14]. Each of them has attempted to localize disturbances in the state of the eye adapted to an average level of luminance in its field of view. The hypotheses effected in further research into possibilities of assessment of discomfort glare. However, the approaches used in the assessment differ significantly between one another, mostly due to the different assumed causes of the studied phenomenon, and in consequence, various methodologies of the used procedure. This article expounds the results of efforts taken to formulate an objective and CIE-guidelines-compliant method which involved setting up a prototype stand allowing to estimate discomfort glare.

2. Method for measuring discomfort glare based on the analysis of a digital image of the room

Considering the research aiming at explanation of the nature of discomfort glare and at evaluation of factors affecting the severity of this phenomenon, it can be concluded that:

- the degree of discomfort glare is directly proportional to the luminance and angular size of the glaring source, and inversely proportional to the luminance of the background to which the eye has adapted;
 - the sensation of discomfort is the stronger the smaller the angular deviation of the glaring light source position from the direction of observation;
 - a glaring source affects less if it is located above the direction of observation, and more if it is positioned in lower or side areas of the observer's field of view;
 - glaring effects of various kinds of light sources can be disparate, for instance stronger effects have been observed in case of incandescent sources than in discharge and LED sources;
 - susceptibility to discomfort glare is dependent on the observer's psychophysical condition.
- CIE publication [5] introduces a method for evaluation of discomfort glare referred to as CIE Unified Glare Rating, in which for each source of glare (i.e. a luminaire) an *UGR* index is determined according to the formula (1):

$$UGR = 8 \cdot \log \left(\frac{0,25}{L_b} \sum \frac{L^2 \cdot \omega}{p^2} \right), \quad (1)$$

where: L_b – background luminance, L – luminance of luminous parts of each luminaire in the direction of the observer’s eye, ω – solid angle at which the observer’s eye sees the glaring parts of each luminaire, p – position indicator of each glaring luminaire in relation to the direction of observation named Guth’s position index.

Separate guidelines are provided for small, large and non-uniform indirect light sources. In the case of a small source, i.e. with apparent surface area no greater than $0,005 \text{ m}^2$, deviating at least 5° from the direction of observation, the source’s glare is determined by its luminous intensity I , as described by (2) [4].

$$\frac{L^2 \cdot \omega}{p^2} = 200 \cdot \frac{I^2}{r^2 \cdot p^2}. \quad (2)$$

By contrast, if the source is large, the ceiling coverage (CC) ratio is computed according to the formula (3) [6]:

$$CC = \frac{A_0}{A_1}, \quad (3)$$

in which A_0 denotes the apparent surface of the light source, whereas A_1 is the area illuminated by a single source defined as the ratio of room area to the number of sources. When $CC = 1$, it means that the ceiling cannot be seen.

To determine the glare index, denoted in this case as GGR , the following dependencies are recommended (4) and (5) [6]:

$$GGR = \left(\frac{0,18}{CC} - 0,18 \right) \cdot 8 \cdot \log \left(\frac{0,785}{E_i} \cdot \frac{L^2 \cdot \omega}{p^2} \right) + \left(1,18 - \frac{0,18}{CC} \right) \cdot 8 \cdot \log \left[\frac{2 \cdot \left(1 + \frac{E_d}{220} \right)}{(E_i + E_d) \cdot \left(\frac{L^2 \cdot \omega}{p^2} \right)} \right], \quad (4)$$

$$GGR = UGR + \left(1,18 - \frac{0,18}{CC} \right) \cdot 8 \cdot \log \left[\frac{2,55 \cdot \left(1 + \frac{E_d}{220} \right)}{1 + \frac{E_d}{E_i}} \right], \quad (5)$$

where: E_d and E_i denote direct and indirect illuminance in the plane of the eye respectively.

According to the CIE guidelines, a light source will cause the effect of discomfort glare in an observer if its luminance in the direction of observation is greater than $500 \div 700 \text{ cd/m}^2$ [5]. The glare can be reduced by decreasing the luminance of light sources, limiting their luminous areas, or by increasing luminance of the background against which the source is placed.

Determining the glare index in compliance with the UGR method (formula 1) requires the knowledge of measurement values defined in Fig. 1, namely:

- Background luminance L_b , which is defined as averaged luminance of background as seen by the observer, excluding the luminance of glare-causing light sources;

- Luminance L_k of luminous parts of each luminaire which causes the discomfort glare effect, measured in the direction of the observer's eye, ($k = 1 \dots n$, where n – the number of light sources generating discomfort glare experienced by the observer in the room);
- Solid angle ω_k which contains luminous parts of each luminaire ($k = 1 \dots n$);
- Guth's position index p_k describing correlation between the placement of each glaring source and the level of discomfort caused by this source. Its values were determined by Luckiesh and Guth experimentally, and are usually available in a tabular or graphical form (as in e.g. [5]).

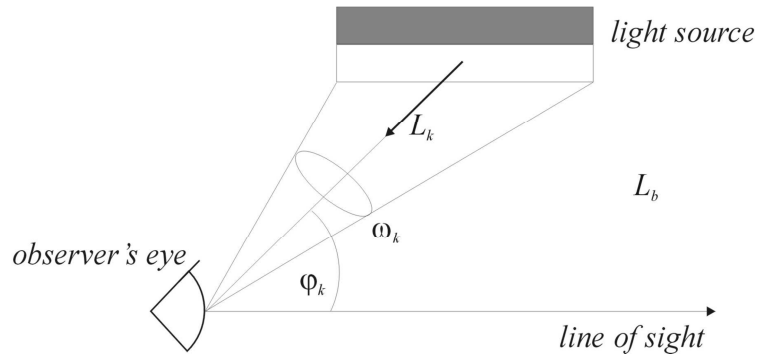

Fig. 1. Graphical representation of the quantities necessary to determine the UGR index: L_k – luminance of the source in the direction of the observer's eye, ω_k – solid angle, ϕ_k – deviation of the center of the glaring source from the direction of observation, L_b – background luminance.

All of the above-mentioned quantities can be collected by means of analysis of the image acquired by mapping the luminance distribution in the analyzed area onto an array detector, assuming that the area roughly corresponds to the field of view of the human observer. As a rule, data are recorded in a digital form.

Assuming that an elementary area with the luminance $L_{\alpha ij}$ equivalent to the observer's field of view (as measured from the position of his/her eyes) is mapped onto a single photosensitive element with the surface S_{ij} of the pixel array detector, the illuminance of this element's surface can be expressed as (6)

$$E_{ij} = \frac{\tau \cdot \Phi_{ij}}{S_{ij}} \text{ [lx] }, \quad (6)$$

where Φ_{ij} – luminous flux incident on the element with coordinates (i, j) of the detector, τ – transmission coefficient of the imaging system.

Luminous flux Φ_{ij} is dependent on the luminance $L_{\alpha ij}$ of the area in the direction α_{ij} whose image has been recorded on the photosensitive element. With the known illuminance E_{ij} , the value of luminance $L_{\alpha ij}$ can be established using the relation (7):

$$L_{\alpha ij} = \frac{\tau \cdot E_{ij}}{\omega_{ij} \cdot \cos \alpha_{ij}} \text{ [cd/m}^2\text{] }, \quad (7)$$

where: ω_{ij} – solid angle enclosing an elementary area in the field of view, α_{ij} – angle between a normal to the luminous area and the straight line connecting the elementary area of the luminaire mapped onto the photosensitive element with coordinates (i, j) with the center of the element and passing through the center of the pupil of the imaging system.

Relation (7) implies that digital values representing the illuminance on the surfaces of specific elements of the array constitute the luminance distribution in the field of view of the imaging system. Accordingly, analysis of this mapping will provide data for the numerical evaluation of discomfort glare.

2.1. Methods for determining partial quantities

According to the definition provided by International Commission on Illumination, background luminance is formed by the luminance of all objects present in the observer's field of view except for the sources of glare [5]. Its value determines the level of eye adaptation for a person remaining inside the room. The objects which surround the observer are made of various materials, and therefore their luminance can vary to a considerable degree. Besides, they are located in both horizontal and vertical planes, and all of them exert influence on the adjustment of visual system sensitivity to a level peculiar to an individual.

Assuming the level of adaptation as a constant reference state at which glare does not occur, it can be conjectured that background luminance is the average luminance of items within the field of view (excluding the sources of glare), and as such can be calculated from the relations (8):

$$L_b = \frac{1}{N_b} \sum_k L_{ijk}, \quad (8)$$

where N_b – number of pixels qualified as the background, L_{ijk} – luminance of the area imaged onto the k^{th} cell.

From the perspective of numerical evaluation of discomfort glare, background luminance is not a critical parameter. For that matter, if L_b represents the actual value of background luminance, whereas L_b^* – the error-burdened value, then the relative difference of these values will be formula (9):

$$\Delta L_b = \frac{L_b^* - L_b}{L_b} \cdot 100\% . \quad (9)$$

Assuming that the remaining values are not burdened with error, the absolute difference of glare UGR indices is as follows (10):

$$UGR^* - UGR = -8 \log(1 - \Delta L_b). \quad (10)$$

This relationship is illustrated in Fig. 2.

A consequence of (10) is that error of background luminance calculation has only minor influence on the value of the UGR index. For instance, if the measured value of background luminance differs from the actual value by about $\pm 30\%$ (according to equation (9)), the absolute value of UGR index difference will amount to just one unit. Practically, this means that the measurement of background luminance should have an error of no more than 25% to ensure that the index UGR^* is contained within the $UGR \pm 1$ interval.

Luminance of glare sources is determined concurrently with background luminance in the process of pixel classification. This process is tantamount to resolving to which of the cells have the images of these sources been mapped. In particular, if the luminance of the area mapped onto a pixel exceeds the threshold value, the pixel is assigned as a source area. At the same time, attention should be paid to luminance values of neighboring pixels, because it may happen that some of the pixels will appear as high luminance areas, while actually being so called “stuck pixels”. After classifying a consequent span of the array as representing a source of glare, its average luminance is calculated. A similar calculation is carried out for each group of pixels classified as a source.

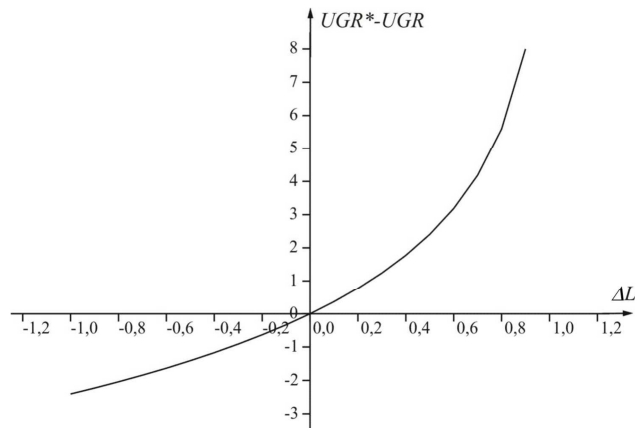

Fig. 2. Influence of background luminance calculation error on the value of the *UGR* index [15].

In the evaluation of discomfort glare, the location of sources in a room is described by assigning to each of the sources a position index value p . This indicator is established for any specific reference point which represents the eyes position of a person performing visual tasks in the chosen direction of observation. Consequently, with a change of the reference point all the values of location indicators for all the sources in the room are modified. Knowledge of placement geometry of the sources and the observer allows calculating the location indicator according to the following relation (11) [16]:

$$\frac{1}{p} = \frac{d^2 \cdot EXP}{d^2 + 1,5 \cdot d + 4,6} + 0,12 \cdot (1 - EXP), \quad (11)$$

where EXP , d , and s can be derived from 11a, 11b and 11c respectively:

$$EXP = e^{(-0,18 \cdot \frac{s^2}{d} + 0,011 \cdot \frac{s^3}{d})}, \quad (11a)$$

$$d = \frac{r}{h}, \quad (11b)$$

$$s = \frac{t}{h}. \quad (11c)$$

In the above formulas, the respective figures represent:

r – the distance from the observer’s eye to the point of intersection between the straight line connecting it with the point of fixation and the plane perpendicular to the direction of observation containing the center of a luminaire;

t – the distance between the point of intersection of the plane perpendicular to the direction of observation containing the center of a luminaire with the straight line coincident with the direction of observation and orthogonal projection of the center of a luminaire on the vertical plane coincident with the straight line representing the direction of observation;

h – the distance from the center of a luminaire to its orthogonal projection on the vertical plane coincident with the straight line representing the direction of observation.

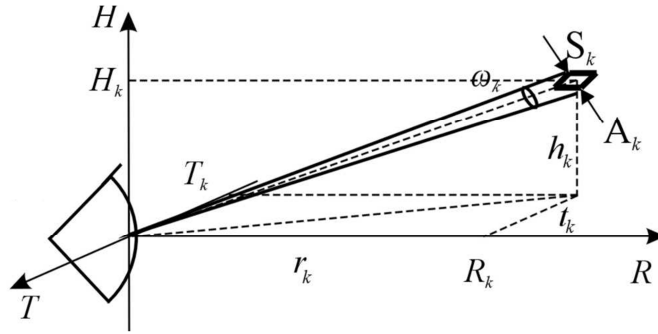

Fig. 3. Size and position of a luminaire in relation to the observer's eye.

To identify the location of a point in the field of view, it is necessary to establish its coordinates R, T, H (Fig. 3) [5]. If the center S_k of the k^{th} luminaire (Fig. 4), defined by the coordinates R_k, T_k, H_k , is mapped onto the surface of a pixel array detector, it will be represented by the coordinates T'_k and H'_k . As for the coordinate R'_k , it will be derived from the distance between the detector's surface and the plane coincident with the pupil of the registering system f . Conforming to CIE guidelines [5], the Guth's position index can be determined through interpolation of data contained in the table of location indices. Specifically, it can be resolved by calculating the tangent (H/R) of the angle between the direction of observation and the straight line connecting the point which is the orthogonal projection of the center S_k of the k^{th} luminaire on the vertical plane coincident with the optical axis of the eye (i.e. straight line which determines the direction of observation).

For the assumed rectilinear propagation of rays, the point in the center of the k^{th} luminaire is characterized by the following ratios (12):

$$\begin{aligned} \frac{T_k}{R_k} &= \frac{T'_k}{R'_k}, \\ \frac{H_k}{R_k} &= \frac{H'_k}{R'_k}, \end{aligned} \quad (12)$$

where T'_k and H'_k are the coordinates on the surface of the array detector. Their distances from the point $(0, R'_k, 0)$, i.e. the center of the array, are equal respectively to t'_k and h'_k , and represent the distance between the photosensitive element on the surface of which the center of the k^{th} luminaire has been mapped and the center of the array.

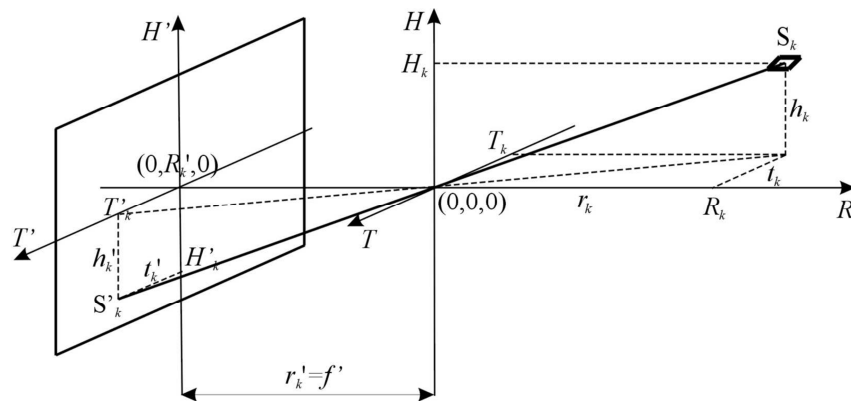

Fig. 4. Coordinate system for evaluation of spatial distribution of light sources.

The array detector is a discrete system which allows to sample the registered image with a precision dependent on the dimensions of a single photosensitive element. Assuming that such an element is a rectangle with sides of length equal to a and b (Fig. 5), distances of the center of the k^{th} photosensitive element (with coordinates T'_k and H'_k) from the center of the matrix can be expressed as (13):

$$t'_k = i_k \cdot b, \quad h'_k = j_k \cdot a, \quad (13)$$

where: i_k, j_k – the distance of a given array cell (pixel) from the center of the array, formulated in terms of number of rows and columns.

Relying on the above-mentioned dependencies, coordinates of the center of the k^{th} luminaire can be represented as (14):

$$\frac{t_k}{r_k} = \frac{i_k \cdot b}{f'}, \quad \frac{h_k}{r_k} = \frac{j_k \cdot a}{f'}. \quad (14)$$

Distances r_k, t_k and h_k (Figs. 3 and 4) denote respectively: r_k – the distance from the observer’s eye to the point of intersection between the straight line connecting it with the point of fixation and the plane perpendicular to the direction of observation containing the center of the k^{th} luminaire; t_k – the distance between the point of intersection of the plane perpendicular to the direction of observation containing the center of the k^{th} luminaire with the straight line coincident with the direction of observation and orthogonal projection of the center of the k^{th} luminaire on the vertical plane coincident with the straight line representing the direction of observation; h_k – the distance from the center of the k^{th} luminaire to its orthogonal projection on the vertical plane coincident with the straight line representing the direction of observation.

If the coordinates (i_k, j_k) denoting the location of the center of the image corresponding to the k^{th} luminaire on the array detector are known (and assuming that both the distance from the detector to the pupil of the imaging system and dimensions of a single photosensitive element are given), it is possible to calculate the applicable value of the Guth’s position index. To discuss the dimensions of an area mapped onto the detector’s surface, the part S_k of a luminaire registered on the surface of the detector’s elementary area, with coordinates (T'_k, H'_k) (Fig. 5), should be considered.

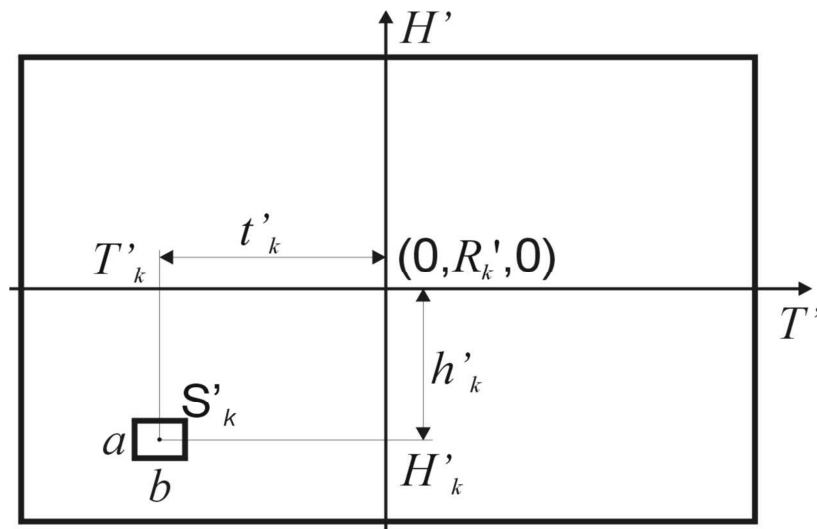

Fig. 5. Coordinates of a point of the array

Distances of the projections of this photosensitive element on axes T' and H' to the center of the coordinate system (i.e. the center of the matrix) are equal respectively to t_k' and h_k' . Because of the assumption that the considered medium is neither a density gradient nor a turbulent one, in the discussed configuration light propagates rectilinearly. Given the above, the following can be asserted (15):

$$\omega_k = \omega_{S_k}, \tag{15}$$

where ω_k is the solid angle at which the k^{th} photosensitive element is visible from the center of the pupil of the imaging system, whereas ω_{S_k} is the solid angle at which the part S_k of a light source mapped on the k^{th} photosensitive element is visible.

In general, the solid angle corresponding to a luminaire is established from the relation (16) [5]:

$$\omega_{S_k} = \frac{A_{S_k}}{l^2}, \tag{16}$$

where A_{S_k} – the area of the projection of the luminous part of a luminaire on a plane perpendicular to the straight line connecting the center of the pupil with the center of the luminous area, l – the distance from the center of the luminous part of the luminaire to the eyes of the observer.

In a similar way, the solid angle ω_k can be determined as (17):

$$\omega_k = \frac{A_k}{l_k^2}, \tag{17}$$

where A_k – the area of the projection of the k^{th} photosensitive element on a plane perpendicular to the straight line connecting the center of this element with the center of the pupil of the imaging system, l_k – the distance from the center of the k^{th} photosensitive element to the center of the pupil of the imaging system.

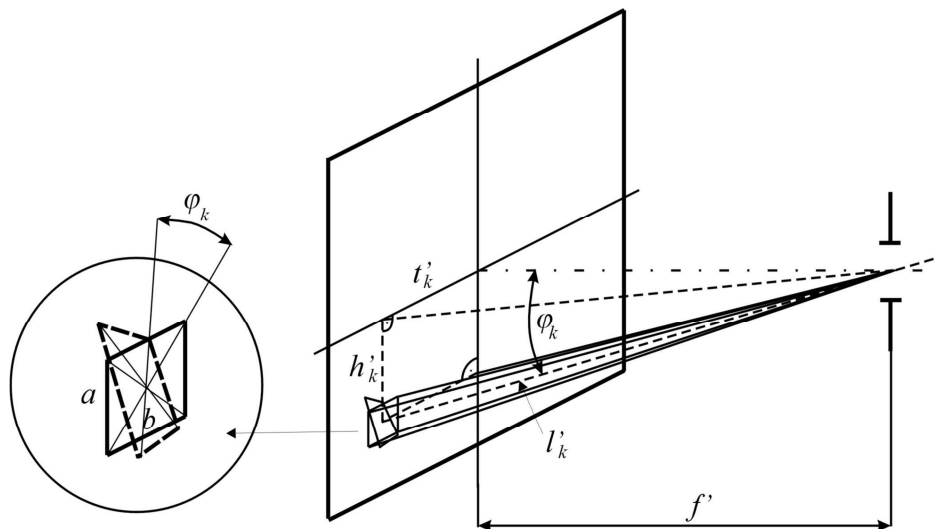

Fig. 6. Determination of angle coordinates of a photosensitive element of the array.

The surface area of the projection of the k^{th} photosensitive element is relation (18):

$$A_k = a \cdot b \cdot \cos \varphi_k, \tag{18}$$

where a and b are dimensions of the photosensitive element, and the angle φ_k is defined as shown in Fig. 6.

The distance from the center of the k^{th} photosensitive element to the center of the pinhole diaphragm is determined as follows (19):

$$l'_k = \frac{f'}{\cos \varphi_k}, \quad (19)$$

where f' denotes the axial distance of the detector's surface to the plane coincident with the pupil of the imaging system, whereas φ_k remains as defined in Fig. 6.

The angle can be expressed as (20):

$$\cos \varphi_k = \frac{f'}{\sqrt{h_k^2 + t_k'^2 + f'^2}}. \quad (20)$$

Therefore, having considered the above stated dependencies, formula (17) assumes the form (21):

$$\omega_k = \frac{a \cdot b \cdot f'}{\sqrt{h_k^2 + t_k'^2 + f'^2} \cdot (h_k^2 + t_k'^2 + f'^2)}. \quad (21)$$

Furthermore, taking into account relation (13), this equation can be written as (22):

$$\omega_k = \frac{a \cdot b \cdot f'}{\sqrt{a^2 j_k^2 + b^2 i_k^2 + f'^2} \cdot (a^2 j_k^2 + b^2 i_k^2 + f'^2)} \quad \text{or} \quad \frac{a \cdot b \cdot f'}{(a^2 j_k^2 + b^2 i_k^2 + f'^2)^{\frac{3}{2}}}. \quad (22)$$

With the known parameters of the imaging system (such as distance from the pupil to the detector's surface f' , and dimensions of a single photosensitive element), and relying on the coordinates (i_k, j_k) defining the placement of the considered photosensitive element on the surface of which a part of a light source has been mapped, it is possible to calculate the elementary solid angle ω_{Sk} at which the luminous flux is incident on the surface of the selected photosensitive element.

In fact, the farther is the detection element placed from the center of the array, the lower is the measure of the corresponding solid angle. Disregarding these differences would result in occurrence of error δ_ω whose value can be determined by relating the measures of individual solid angles ω_k to the value of the solid angle corresponding to the axial photosensitive element ω_0 (23):

$$\delta_\omega = \frac{\omega_0 - \omega_k}{\omega_0}. \quad (23)$$

Taking into account (22) and (23) results in:

$$\delta_\omega = 1 - \frac{f'^3}{\sqrt{a^2 j_k^2 + b^2 i_k^2 + f'^2} \cdot (a^2 j_k^2 + b^2 i_k^2 + f'^2)}. \quad (24)$$

If, therefore, a light source is mapped onto a surface consisting of N photosensitive elements of a CCD array, then its size ω_{Sk} is determined by the sum of solid angles ω_k corresponding to these array cells (25):

$$\omega_S = \sum_{k=1}^N \omega_k. \quad (25)$$

In this way, knowing the measures of solid angles affiliated with individual photosensitive elements of the array detector array, it is possible to calculate the angular size of a light source registered on its surface.

3. Conclusions

Limiting the extent of discomfort glare caused by artificial lighting is one of the most important factors in ensuring quality of indoor illumination. Be that as it may, thus far there have been neither methods of measurement nor measuring instruments which would allow a successful practical realization of this aim. There is awareness of general relations between the experienced feeling of discomfort resulting from performing visual tasks in a glare-prone environment and properties of the lighting system accompanied by the visual conditions created by it. Basically, these relations include background luminance – understood as average luminance in the field of visual performance, and luminance of glaring areas along with their size and spatial distribution in relation to the observer's eyes.

The development and popularization of arrays of detectors has rendered possible attempts at construction of various measuring instruments which take advantage of the new capabilities of such detectors. The detectors have also found application in lighting technology, e.g. in measurement of luminance or in colorimetric measurements [17, 18]. Due to the specificity of their construction, these detectors are well suited for application in geometric measurements, in this way offering a possibility of devising systems making use of both types of measurements, i.e. geometric and photometric. A good example of such a system is precisely the device for measuring discomfort glare.

The present article proposes a method for measuring discomfort glare which employs a numerical description of this phenomenon, and makes use of a digital luminance distribution map. It presents algorithms for determining partial quantities which are necessary for the calculation of the *UGR* index. Also, it expounds the impact of background luminance measurement accuracy on the value of the above index. The developed methods for determining the location index and size of the glare sources using the parameters of the registering system (focal length and the size of a single photosensitive element in the array) and coordinates of their images on the detector's surface are thoroughly discussed.

Acknowledgements

Article realized within the research framework S/WE/4/13 provided in the Department of Optoelectronics and Lighting Technology, Bialystok University of Technology in 2013.

Literature

- [1] Lindsay, P.H., Norman, D.A. (1977) *Human information processing: An introduction to psychology*. New York: Academic Press.
- [2] *International Lighting Vocabulary* CIE17.4 (1987).
- [3] EN 12665:2008, *Light and lighting – Basic terms and criteria for determining the requirements for lighting* (2008).
- [4] EN 12464-1:2011 *Light and lighting. Illumination of work places. Part 1: Indoor work places* (2011).
- [5] *Technical Report: Discomfort Glare in Interior Lighting*, CIE 117 (1995).
- [6] *CIE Collection on Glare* CIE 146, 147:2002 (2002).
- [7] Yamada, M., Fukuda, T. (1986) Quantitative evaluation of eye movements as judged by sight-line displacements, *Journ. of Soc. of Mot. Pic. and Telev. Eng.*, (95), 1230–1241.
- [8] Yamada, M., Fukuda, T., Hirota, M. (1990) Development of an eye-movement analyzer possessing functions for wireless transmission and autocalibration, *Med. and Biol. Eng. and Conc.*, (28), 317–324.

- [9] Schenkman, B., Fukuda, T., Persson, B. (1999) Glare from monitors measured with subjective scales and eye movements, *Displays*, (20), 11–21.
- [10] Yamada, M., Fukuda, T., Hirota, M. (1989) A new eye movement analyzer: auto calibration and wireless transmission, In *Proc. of IEEE Engineering in Medicine & Biology Society Conference*, 861–863.
- [11] Fugate J.M., Fry G.A. (1956) Relation of changes in pupil size to visual discomfort, *Illum. Eng.*, (51), 537–549.
- [12] Berman, S., Bullimore, M., Jacobs, R., Bailey, I., Gandhi, N. (1994) An objective measure of discomfort glare, *Journ. of Illum. Eng. Soc.*, (23): 40–9.
- [13] Belkic, K. (1986) Light stress and the cardiovascular system: the glare pressor test, *Ergonomics*, (29), 563–568.
- [14] Murray, I.J., Plainis, S., Carden, D. (2002) The ocular stress monitor: a new device for measuring discomfort glare, *Light. Res.&Techn.*, (34), 3: 231–242.
- [15] Blaszczak, U.J. (2004) The method of estimation of background luminance in the objective glare measurements, *Proceedings of SPIE*, 5566, 234–238.
- [16] *Technical Report TC-3.4: Discomfort glare in the working environment*, CIE, (1981).
- [17] Wienold, J., Christoffersen, J. (2006) Evaluation methods and development of a new glare prediction model for daylight environments with the use of CCD camera, *Energy and Buildings*, (38), 743–757.
- [18] Hirning, M.B. et al. (2013) Post occupancy evaluations relating to discomfort glare: A study of green buildings in Brisbane, *Building and Environment*, (59), 349–357.