

VIS CAMERA STUDIES OF THE COMBUSTION PROCESS OF PYROTECHNIC RETARDERS OF NGP-76 UNDERWATER FIFLE GRENADES

Miszczak M., Warchoł R., Gędziorowski M.P., Piecuch M., Grzeczka G.

Naval Academy, Military Institute of Armament Technology, Zielonka, Warsaw, Poland

ABSTRACT

The study presents the combustion process of the multi-segment, low-gas pyrotechnic column of the warhead retarder of the NGP-76 underwater rifle grenade, designed to combat divers with an underwater shock wave. The combustion process, i.e. process from the ignition of the first segment of the retarder to the completion of combustion of its last segment, was recorded with a VIS camera filming at 30 frames per second. The rapid, short combustion of these outermost segments containing zirconium and Pb_3O_4 (minium) was accompanied by a blinding plume of brightly glowing particles of zirconium dioxide and lead vapor. The combustion of the middle segments formed from the MGS-54 pyrotechnic mixture containing $BaCrO_4$, $KClO_4$ and Sb_2S_5 , determining the duration of the delay, i.e. the delay produced by the retarder, was much slower and longer than that of the outermost segments. During the combustion of each MGS-54 segment, the combustion front took the form of a flat section in the initial part of the segment, i.e. in the area of higher density, while in the further part of the segment (with lower density) the shape of the front became irregular. At the MGS-54 segment boundary, the combustion front halted briefly. Behind the combustion front, a conical tail of luminous solid combustion products became clearly visible at the MGS-54 segment boundary. The gaseous combustion products of the MGS-54 segments, formed in small amounts and revealed as white plumes, were probably KCl vapor and/or sulfur dioxide. After combustion, the retarder column of the MGS-54 segments was green in color due to the presence of chromium compounds, possibly $Ba(CrO_2)_2$.

Keywords: underwater rifle grenade NGP-76, Pyrotechnic retarder, multi-segment pyrotechnic column, combustion front, VIS registration, shock wave diver incapacitation.

ARTICLE INFO

PolHypRes 2022 Vol. 78 Issue 1 pp. 31 – 42

ISSN: 1734-7009 **eISSN:** 2084-0535

DOI: 10.2478/phr-2022-0002

Pages: 12, figures: 6, tables: 0

page www of the periodical: www.phr.net.pl

Original article

Submission date: 3.11.2021 r.

Acceptance for print: 10.12.2022 r.

Publisher

Polish Hyperbaric Medicine and Technology Society



INTRODUCTION

Investigations by means of a VIS camera of the combustion process of multi-segment, column pyrotechnic charge retarder warhead assemblies of NGP-76 underwater rifle grenades (Fig. 1a, b, c) intended to combat divers by means of an underwater shock wave,

presented in this article are aimed at identifying and recording the phenomena occurring during the combustion of these pyrotechnic columns, in the context of the operational safety and reliability of the operation of these types of grenades.



a



b

Underwater rifle grenade NGP-76:
a – stabiliser with fin assembly, b – warhead

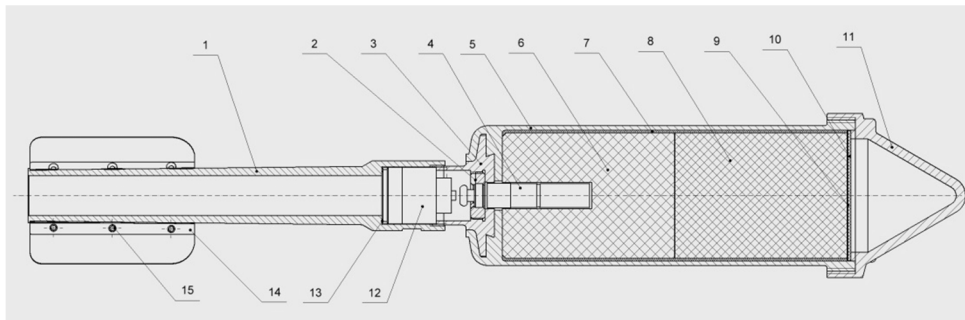

A cross-section of the underwater rifle grenade NGP-76

1 – stabiliser reduction sleeve, 3 - steel connecting element between the warhead and the shaft, 4 - pyrotechnic warhead retarder assembly, 5 - warhead body, 6 - rear cube of the crushing MW, 7 - paraffin layer, 8 - front cube of the MW, 9,10 - shock absorbing spacers, 11 - ballistic head cap, 12 - bottom fuse DC-1, 13 - safety washer, 14 - fin assembly of the stabiliser, 15 - rivets attaching the fin assembly to the stabiliser body.

Fig. 1 (a,b,c): Underwater rifle grenade NGP-76 and its elements.

Prior to the above-mentioned pyrotechnic retarder combustion studies, crucial initial stages of the experimental work were the preparation of the samples and their X-ray defect examination using the Real Time-X-ray Radioscopy (RTR) technique).

EXPERIMENTAL RESEARCH

PREPARATION AND DESCRIPTION OF TEST SAMPLES

From the NGP-76 submarine grenade warheads, the booster primer connected to the retarder was removed, the two aforementioned elements were separated from each other, and then the pyrotechnic retarder (Photo. 2) was cut longitudinally into semi-cylindrical halves, each of which constituted a sample (Photo. 3) ready for further testing, i.e. combustion.



Photo 2. Pyrotechnic retarder of underwater rifle grenade NGP-76.

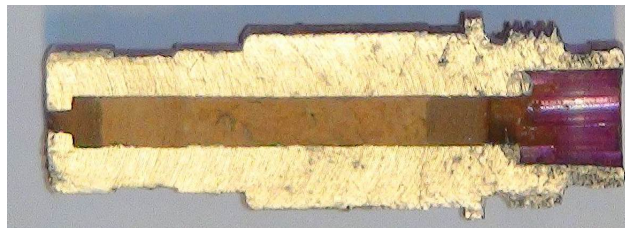
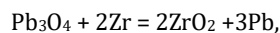

Photo 3. Pyrotechnic retarder of an underwater rifle grenade NGP-76 cut lengthwise.

The test sample consisted of a seven-segment pyrotechnic column pressed into an aluminium body. The length of the pyrotechnic column was 32.0 mm, with a diameter of 3.2 mm at the section containing the first six segments and part of the seventh segment. The diameter of the pyrotechnic column was approximately 2.1 mm at the tapered, exit section of the last (seventh) segment. The extreme, dark brown segments of the pyrotechnic charge, i.e. the first two - the inlet segments (difficult to distinguish) are intended to initiate and stabilise the ignition phase of the retarder, while the last - the outlet segment, is intended to excite the detonating primer, initiating the explosion of the main explosive charge of the NPG-76 grenade. The segments contain lead compounds and zirconium. The dark brown colour of these mixtures is due to the presence of red lead (Pb_3O_4) in their compositions. The first segment, approximately 0.4 mm in length, was made from the SC-1 pyrotechnic mixture containing 2.0 per cent parts by weight of nitrocellulose (colloxylin), 74.5 per cent parts by weight of lead (II, IV) oxide (Pb_3O_4) and 23.5 per cent parts by weight of zirconium powder (Zr). Thus, Pb_3O_4 and Zr powder were mixed in a stoichiometric ratio.

The combustion reaction equation is given in the Swiss patent description CH₆₄₈₀₁₂ (A5) [1] and the book [2]:



The combustion of pyrotechnic mixture SC-1 produces hot particles of zirconium dioxide and lead vapour (the melting point of Pb is 327 °C, and the boiling point is about 1750°C).

The second segment with a length of about 4.4 mm was made of pyrotechnic composition W-11 containing 24.2% parts by weight of barium chromate (VI) ($BaCrO_4$), 52.3% parts by weight of Pb_3O_4 , 16.3% parts by weight of Zr powder, 2.9% parts by weight of potassium chlorate (VII) ($KClO_4$), 2.3% parts by weight of sulphur and 2.0% parts by weight of colloxylin.

The four inner (middle), light brown pyrotechnic segments forming the primary retarding segment, approximately 23.0 mm in length, were made from a pyrotechnic mixture of MGS-54 containing 78.2% parts by weight of $BaCrO_4$, 9.9% parts by weight of antimony pentosulphide (Sb_2S_5) and 2.0% parts by weight of colloxylin. The colour of the MGS-54 segments was due to the presence of Sb_2S_5 and $BaCrO_4$. The final, outlet segment, approximately 4.2 mm long, was made from the W-11 composition.

Thus, the order of combustion of the seven segments of the pyrotechnic charge was as follows: SC-1, W-11, MGS-54, MGS-54, MGS-54, MGS-54 oraz W-11.

DEFECTOSCOPIC TESTING OF SAMPLES

Directly preceding combustion, each sample was subjected to roentgenographic defectoscopic examination in the detection chamber of the RTR diagnostic system type MU-17F-225-9 developed by YXLON International X-ray Corporation.

As a result of the defectoscopic examination, it was found that the pyrotechnic column segments had no visible structural defects in the form of cracks or indentations (cavities) (Fig. 4).



Photo 4. RTR photo of the NGP-76 underwater rifle grenade pyrotechnic retarder.

The density of the MGS-54 segments along their length was not uniform. On the outlet side of the retarder body, the density of each MGS-54 segment was lower than on the ignition side. Segments SC-1 and W-11 were the darkest on the RTR roentgenogram due to the presence of Pb_3O_4 in their composition. The boundary between the SC-1 and W-11 segments could not be distinguished on the RTR roentgenogram due to their similar X-ray absorption capacity.

COMBUSTION TESTING OF SAMPLES

Following the defectoscopic tests, combustion of each sample was initiated with a laser beam (CO_2 laser) from the right side (Fig. 5), i.e. from the side of the SC-1 pyrotechnic segment.

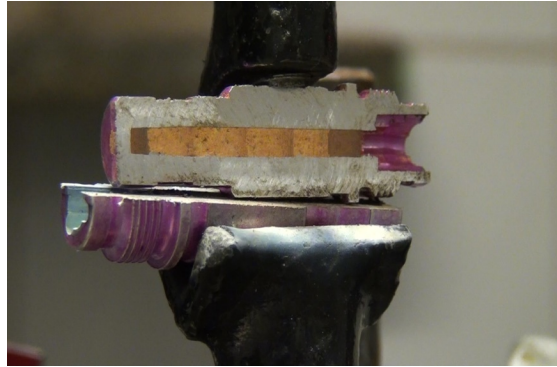

Photo 5. Test sample - longitudinally cut pyrotechnic retarder of an NGP-76 underwater rifle grenade, immediately before ignition by laser beam.

The combustion process of the semi-cylindrical, seven-segment pyrotechnic column was recorded with a VIS camera filming at 30 frames per second with an image resolution of 1920x1080 pixels.

Images (film frames) were selected from the film (Fig.6(a-u)), recording the most important stages and phenomena occurring during the combustion of the sample.



Fot. 6a; t=0,43(3)s

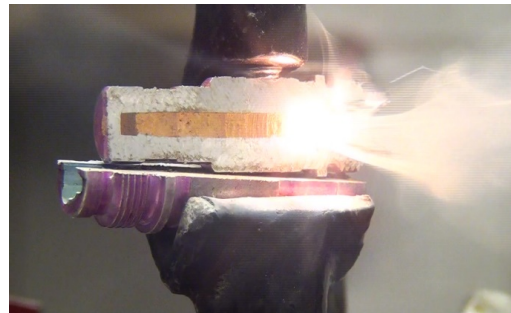

Fot. 6b; t=0,46(6)s



Fot. 6c; t=0,73(3)s

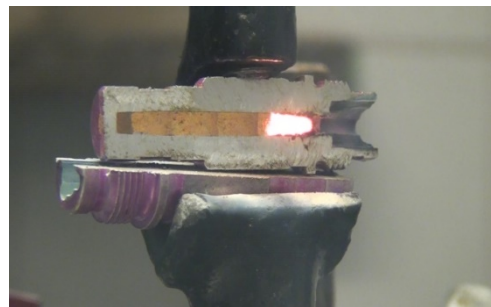

Fot. 6; t=1,06(6)s

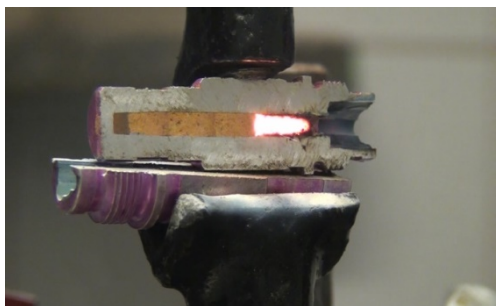

Fot. 6e; t=1,33(3)s

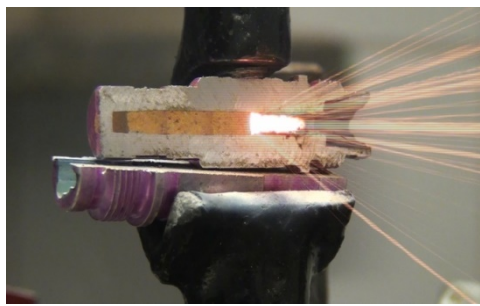

Fot. 6f; t=1,36(6)s

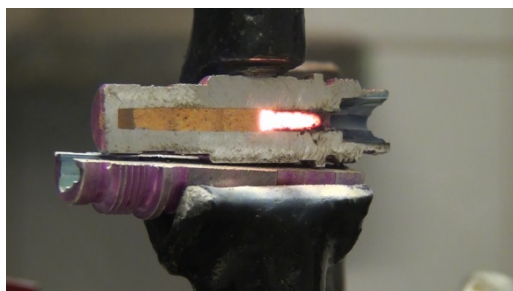

Fot. 6g; t=1,4s

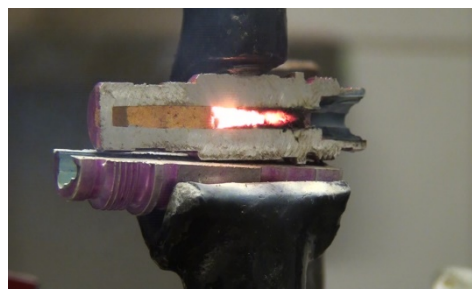

Fot. 6h; t=2,06s

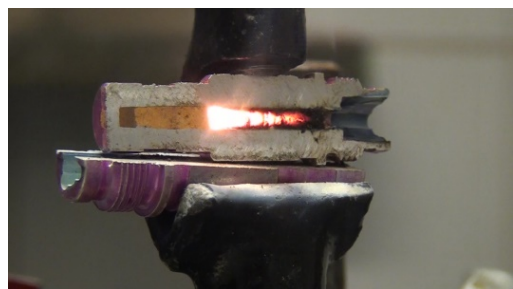

Fot. 6i; t=2,5s

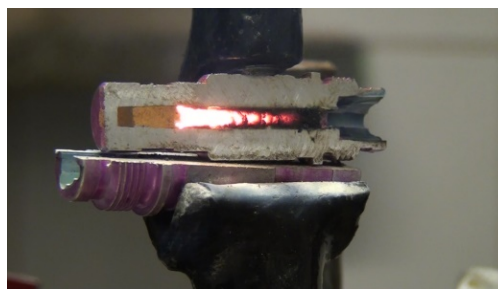

Fot. 6j; t=3,06(6)s

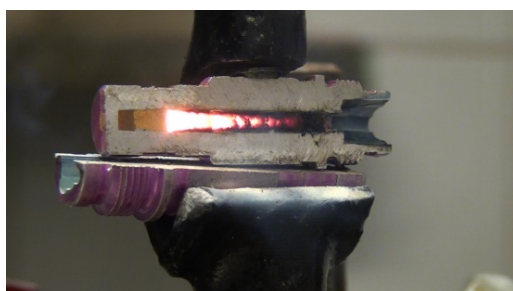

Fot. 6; t=3,33(3)s

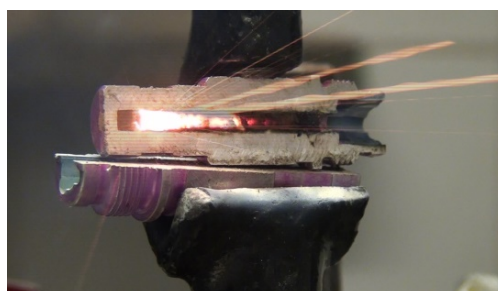

Fot. 6l; t=3,83(3)s

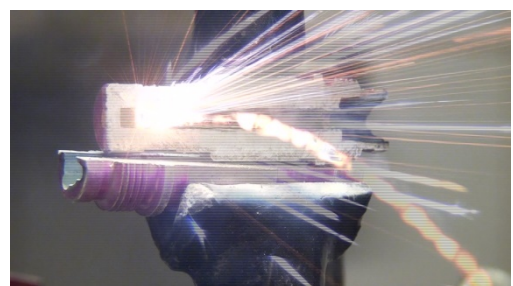

Fot. 6m; t=3,86(6)s



Fot. 6n; t=4,06(6)s



Fot. 6o; t=4,1s

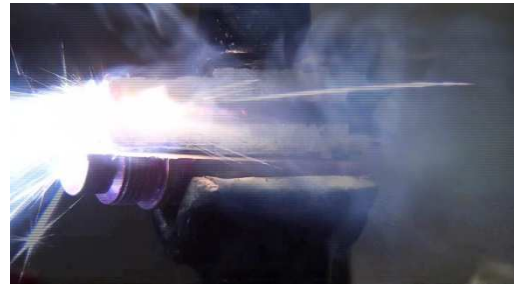

Fot. 6p; t=4,13(3)



Fot. 6r; t=4,16(6)s



Fot. 6s; t=4,2s



Fot. 6t; t=5,46(6)s

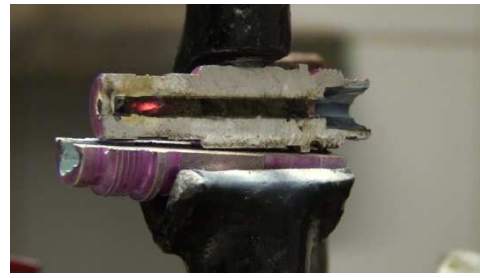

Fot. 6u; t=6,23(3)

Photo 6 (a-u): Sequence of selected photographs of the combustion process of the multi-segment pyrotechnic column of the NGP-76 underwater rifle grenade retarder. Time points of the combustion process are indicated under each photograph.

The combustion of the first two pyrotechnic segments (SC-1 and W-11) and the last exit segment (W-11) was dominated by a dazzling plume of brightly glowing ZrO_2 particles (Photo 6(a, b, m, n, o, p, r)) and Pb vapour (Fot5(b, n, o, p, r, s)).

Based on the duration of intense ZrO_2 glow, it was estimated that the burning time of the first two segments: SC-1 and W-11 was in the range of 0.1-0.2 s.

Unfortunately, the blinding combustion products of these segments prevented the observation of the initial combustion phase of the first retarding segment (MGS-54).

Stable combustion of the first retarder segment of the MGS-54 (Fig. 6c) was visible approximately 0.73 s following ignition of the SC-1 segment. Fig.6c shows a rectilinear combustion front located in the higher density area of the first MGS-54 segment. Also visible is a white haze (plume) of gaseous combustion products of the MGS-54 segment, which may be KCl vapour and sulphuric acid(IV) (H_2SO_3) formed by the combination of sulphur dioxide (SO_2) emitted from the MGS-54 with water (moisture) contained in the air. The above-mentioned gaseous products were found [3] during the combustion of a small-gas pyrotechnic mixture of similar composition to the MGS-54 pyrotechnic mixture, i.e.

containing 72% parts by weight $BaCrO_4$, 20% parts by weight Sb_2S_3 , 8% parts by weight $KClO_4$ and 1% parts by weight colloxylin. When the combustion front passes from the higher-density area of the first MGS-54 segment into the lower-density area, the combustion front assumes an irregular shape (Fig. 6d). At the border of the first and second MGS-54 segments, the combustion front 'aligned,' became almost rectilinear and stopped (Fig. 6e), after which it started to move in the second MGS-54 segment, maintaining its rectilinear shape (Fig. 6f-g). The occurrence of the phenomenon of stopping the displacement of the combustion front at the border of adjacent compressed pyrotechnic segments was signalled in [4]. The combustion front became irregular in the area of the second segment of the MGS-54 (Fig. 6h), stopped at the border of the second and third segments of the MGS-54, and then moved into the third segment of the MGS-54, assuming successively a rectilinear (Fig. 5i), irregular shape (Photo. 5j) and stopped at the border of the third and fourth segments of the MGS-54. The combustion front behaved similarly to the third segment of the MGS-54 in the fourth segment of the MGS-54, assuming a regular (Photo. 6k) and then irregular shape (Photo. 6l). As the combustion front moved through the MGS-54 segments, an area ('tail') of luminous solid combustion products

became very visible (Fig. 6c-t). The 'tail' elongated and tapered towards the ignition end of the pyrotechnic column, clearly taking on a conical shape (Fig. 6h-l), which resulted from the sequence of cooling of the solid combustion products starting from the lateral surface (side edges) on the section of the burnt pyrotechnic column. The conical 'tail' consisted of glowing 'cells,' narrowing and fading with increasing distance from the combustion front (Fig. 6i-l).

As a result of the contact between the combustion front and the final exit pyrotechnic segment W-11, this segment ignited abruptly generating a bright plume of ZrO_2 particles propagating in a straight line, backwards (Fig. 6m). The impact of some of the ZrO_2 particles on the burnt segments of MGS-54 sometimes resulted in a fragment(s) of these segments flying backwards along a curved trajectory, visible as a thick, yellow-grey streak (Fig. 6m). The next three frames of the film (Fig. 6n,o,p) show an increasing plume of rectilinear streaks of glowing ZrO_2 particles ejected through the retarder's exit aperture, constituting the basic energy impulse to initiate the action of the next element - the booster primer in the fire chain of the NGP-76 grenade. As the exit fire impulse increased, the fire impulse produced by the W-11 segment backwards decreased (Fig. 6n,o,p). During the aftercombustion of the W-11 segment (Fig. 6r,s), vapours of cooling Pb are visible. In the last two frames of the film (Fig. 6t,u) showing the final phase of cooling of the burnt segmented pyrotechnic column, the green colour of the four burnt segments of MGS-54 is visible. The colour of these segments is due to the presence of chemical compounds containing chromium, probably $Ba(CrO_2)_2$. The presence of this chemical compound was found in the products of combustion of a pyrotechnic mixture of similar composition to MGS-54 [3].

REFERENCES

1. Ryffel K., Delay Composition Containing Primary Explosives, Swiss Patent CH 648012 (A5), 28.02.1985
2. Kubota N., Propellants and Explosives. Thermochemical Aspects of Combustion, 2007, VILEY-VCH Verlag GmbH & Co.KGaA, Weinheim, str. 293. ISBN: 978-3-527-31424-9
3. Sarawadekar R.G., Swarge N.G., Jayaraman S., Agrawal J.P., Use of Bismuth Chromate with Antimony Trisulphide in Delay Compositions, *Energetic Materials*, 2003, 21, 97-107. ISSN: 0737-0652; DOI: 10.1080/07370650390227702
4. Kosanke B.J. (Ed.), *Pyrotechnic Chemistry. Pyrotechnic Reference Series No.4*, 2004, Publisher Journal of Pyrotechnics Inc. p.8-4, p.8-11

dr hab. inż. Grzegorz Grzeczka
Akademia Marynarki Wojennej,
Wojskowy Instytut Techniczny Uzbrojenia
Ul. Wyszyńskiego 7
05 – 220 Zielonka

SUMMARY AND CONCLUSIONS

The combustion process of the segmental pyrotechnic column of the retarder of the warhead of the NGP-76 underwater rifle grenade, i.e. from the ignition of the SC-1 segment to the initial phase of the intensive ejection of the combustion products of the last W-11 pyrotechnic segment through the outlet of the retarder body (Fig. 6o), was recorded on 121 consecutive frames, i.e. the process had a duration of approximately 4s. Thus, the time of the delay of the retarder was within the permissible time range of 3.8 to 4.5 s.

The combustion front moved through successive pyrotechnic segments (without so-called 'skips,' i.e. the very dangerous phenomenon of premature ignition of the last segment (W-11) of the retarder did not occur.

The course of the combustion process in the individual MGS-54 retarder segments was similar, i.e. at the initial section of each MGS-54 segment with a higher density, the combustion front had a flat shape, while at the end section of each segment the shape of the combustion front became irregular. At the boundary of the MGS-54 segments, the combustion front stopped briefly.

Following the combustion front, a conical, elongated tail of luminous, solid products of combustion of the MGS-54 pyrotechnic mixture developed.

The gaseous combustion products of the MGS-54 segments are probably KCl vapour and SO_2 , while the solid combustion product of these segments, which gives the green colour to the burnt pyrotechnic column in the segment, is presumably $Ba(CrO_2)_2$.

The combustion products of the outermost segments: SC-1 and W-11, are hot ZrO_2 particles recorded on the images as a brightly glowing sheaf (bundle) of streaks and Pb vapour visible as white-grey swirling streaks.