

SOME ASPECTS OF VALIDATION OF THE FUEL CONSUMPTION MEASUREMENT METHOD

Sławomir Taubert, Adam Majerczyk

*Motor Transport Institute, Environmental Protection Centre
Jagiellońska Street 80, 03-301 Warsaw, Poland
tel.: +48 22 4385517, +48 22 4385327, fax: +48 22 4385401
e-mail: slawomir.taubert@its.waw.pl, adam.majerczyk@its.waw.pl*

Abstract

Currently produced diesel engines of different manufacturers, used for the same applications, have comparable specific fuel consumption. Therefore, the laboratories measuring fuel consumption, especially in comparative tests, require the use of more accurate methods of measurement. The Environmental Protection Centre of Motor Transport Institute has recently implemented the fuel consumption measurement method using KMA Mobile flow meter produced by AVL company. This device allows to carry out measurements by both volumetric and mass method, thanks to built-in device for measuring the fuel density. Due to some customers requirements the laboratory began with preparations for obtaining accreditation of the Polish Centre of Accreditation for the procedure of measuring fuel consumption by volumetric and mass method. One of the requirements of the Polish Centre for Accreditation is carrying out the validation of the new method. It can be done by comparing the results obtained with new method with the results of the method already validated. The validated method is described in the regulation. This is the carbon balance method described in UN-ECE Regulations No. 101. The calculation of fuel consumption according to this method is based on a measurement of pollutants emissions of carbon dioxide (CO₂), carbon monoxide (CO) and hydrocarbons (THC). This paper describes the fuel consumptions measuring procedure using two methods: mass method using a AVL KMA Mobile flow meter and carbon balance method using the AVL AMA i60 analyzers. To verify measurement results additionally there was fuel consumption measured with using a scale, as a difference of the external fuel tank mass change, from which the vehicle was fuelled during the tests

Keywords: fuel consumption, validation

1. Introduction

The validation of the test method represents confirmation, by the examination and presenting an objective evidence, that the requirements relating to the intended use are met, and that the method is useful to solve a specific problem [1].

The validation procedure for the development of new test methods can be divided into the following steps [2-4]:

- formulation of requirements for the test method, i.e. carrying out the characterization of the test method,
- determining the scope of the test method use, i.e. to determining the variability scope of the test samples,
- developing validation tests program with corresponding criteria values required for the validated method,
- evaluating accuracy of the measurements made using a validated method, i.e. correctness, precision (repeatability and reproducibility), intermediate precision, linearity, and linearity limit,
- determining stability over time,
- determining the limits of detection and quantification,
- comparison of two measurement methods.

This article focuses on the latter of the aforementioned stages of the method validation, i.e. comparing method being validated with other, well-known and already validated method.

For the measurement of fuel consumption, there are three methods of measurement used:

- volumetric,
- gravimetric,
- carbon balance.

The measuring principle of the volumetric method relies on determining the volume of fuel consumed by the engine. Historically, measurements were made by the fuel metering unit in the fuel supply system. The engine was fed alternately from the fuel metering unit and the fuel tank, and to improve the accuracy the result was adjusted based on the temperature of the fuel. Currently, most cars are equipped with a fuel systems working under pressure and with a fuel return lines. Thus, for volumetric measurement, the flow devices are used, which are equipped with measuring means of various construction, such as gear pumps, determining the fuel consumed volume by the number of gears rotations. A volumetric method is widely used in road tests, because most devices are mobile and easy to use for each type of system supplying fuel in a liquid form.

Gravimetric method used in the engine laboratories in its simplest form, is the fuel tank put on the scale. The development of this method is a laboratory equipment operating in automatic mode, filling, emptying and weighing. This method is the simplest one to validate and may be used for measuring consumption of fuel in a liquid and a gaseous form.

In the engine laboratories there is widely used measurement of fuel consumption using carbon balance method, which is based on the measurement of carbon weight in the exhaust gases leaving the engine exhaust system, and then calculating the weight and volume of fuel that was burned to obtain a measured mass of carbon-containing compounds in the exhaust. It is a method that does not require cutting into the vehicle fuel system, therefore is a non-invasive method, with which one can be sure that the measurement will not interfere with the vehicle fuel system. It can be used for measuring consumption of fuel in the liquid and gaseous form.

2. Description of the test

The test carried out compared the fuel consumption values measured by two methods: volumetric one using KMA Mobile flow meter by AVL and carbon balance using a set of AMA i60 analyzers by AVL. In order to verify the values measured by both methods there was simultaneously made measurement of fuel consumption by gravimetric method using a scale, measuring the mass change of the external fuel tank, from which the vehicle was supplied during the test.

The tests were carried out on the Renault Traffic car with diesel engine. Measurements were made at constant speeds equal to 40, 60 and 80 km/h. During the test at a speed of 80 km/h constant loads of 18%, 48% and 73% of maximum power obtained at a given engine speed, were set on a chassis dynamometer. Points of the engine operation in which the test was carried out, are schematically shown in Fig. 1. Additionally, at each point of the engine operation, the measurement of fuel consumption using carbon balance method were carried out at three levels of exhausts dilution with surrounding air (using a venturi orifices of a nominal flow rate of 8, 16 and 24 m³/min).

Vehicle during the tests was supplied alternately from two fuel tanks: the original of the vehicle and external one. Switching the engine supply between the tanks was done with magnetic solenoid. At the ends of the fuel lines with which an external fuel tank was connected to the engine there were non-return valves fitted eliminating the effect of reversing the fuel from these lines when the engine was supplied from the original vehicle tank. External tank was placed on the scale, by means of which the weight change was measured during the test.

The fuel system of the vehicle tested was fitted with KMA Mobile flow meter. The flow meter inlet circuit was connected to the fuel tanks creating the following circulation: fuel tank, engine supply line, flow meter, fuel return line to the tank, the tank, while the outlet circuit was connected to the engine supply circuit (flow meter, high-pressure fuel pump, fuel return line from the engine, flow meter). The circuit outlet incorporated by-pass valve regulating the pressure difference between the engine fuel supply line and fuel return line to the tank.

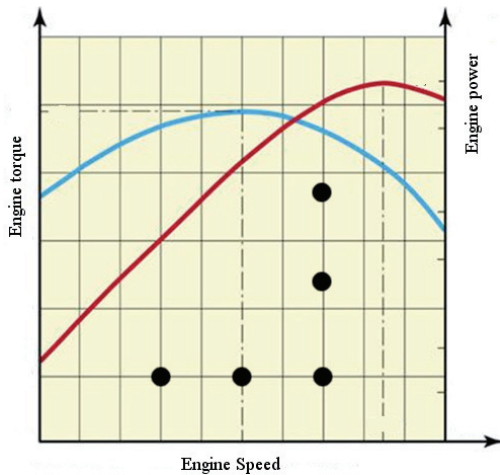

Fig. 1. Engine operation points



Fig. 2. The AVL KMA Mobile flow meter with fuel conditioning system [5]

3. Measuring equipment

For the measurements there was AVL KMA Mobile flow meter used (Fig. 2), PRECISIE 5000D-12000 G's Swiss Quality Medicate Ltd scales and the exhaust sampling system equipped with a critical flow CFV CVS venturies and the set of AVL AMA i60 analyzers. The vehicle tested was mounted on a Zoellner single roller dynamometer.

The KMA Mobile flow meter has two circuits: inlet circuit and outlet circuit. These two circuits are connected with each other by the measuring element (Fig. 3).

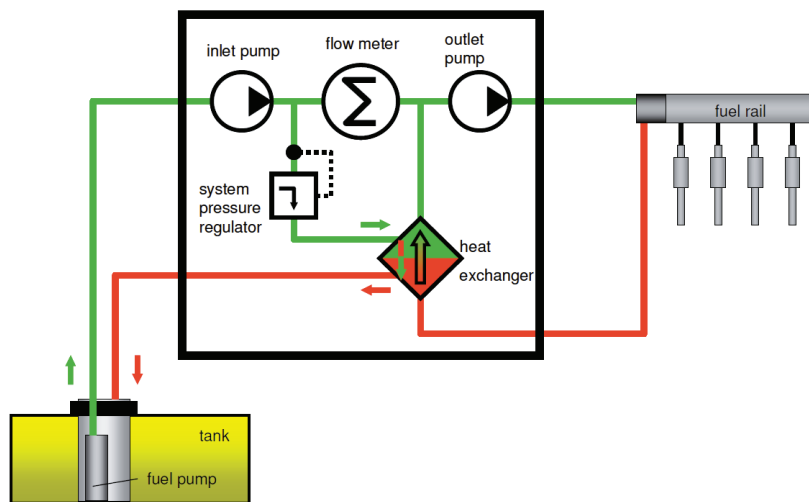

Fig. 3. Diagram of the KMA Mobile flow meter connections with the engine supply system [5]

3.1. Inlet circuit

The inlet pump (Fig. 4, pos. 13.1) delivers fuel from the vehicle tank through the fuel inlet (Fig. 4, pos. 1) to the system pressure regulator (Fig. 4, pos. 8). The system pressure regulator (Fig. 4, pos. 8) is preset to approx. 1.4 bar and any excessive fuel flows back to the tank through the heat exchanger (Fig. 4, pos. 17) and the fuel return line (Fig. 4, pos. 2).

The fuel consumed by the engine flows through the density meter (Fig. 4, pos. 70), the AVL PLU 121 flow meter (Fig. 4, pos. 10) with temperature sensor (Fig. 4, pos. 9) and the return flow pressure regulator (Fig. 4, pos. 11) with a pressure gage (Fig. 4, pos. 12) to the mixing point downstream of the return flow pressure regulator (Fig. 4, pos. 11).

3.2. Outlet circuit

From here the fuel flows through the outlet pump (Fig. 4, pos. 13.4) and the fuel outlet (Fig. 4, pos. 3) to the carburetion system of the engine. The fuel returns through the fuel return line (Fig. 4, pos. 4), the heat exchanger (Fig. 4, pos. 17), the inspection glass with gas bubble detector (Fig. 4, pos. 16) and the purge valve (Fig. 4, pos. 18) to the mixing point downstream of the return flow pressure regulator (Fig. 4, pos. 11). The fuel pressure in the carburetion system is determined by the optional external outlet pressure regulator (Fig. 4, pos. 22), the optional vacuum pressure reducer (Fig. 4, pos. 26) with pressure gage (Fig. 4, pos. 21/27) or the pressure regulator on the engine.

Fuel circulates through outlet pump (Fig. 4, pos. 13.4), fuel outlet (Fig. 4, pos. 3), pressure regulator (Fig. 4, pos. 22), engine and fuel return line. The same amount of fuel as the engine consumes from the circulating quantity, is fed in again through the flow meter (Fig. 4, pos. 10). Fuel consumption is volumetrically recorded by the AVL PLU 121. Mass consumption is then calculated in connection with the density meter (Fig. 4, pos. 70) and the actuator/sensor module. The temperature difference between PLU 121 (Fig. 4, pos. 10) and density meter (Fig. 4, pos. 70) is detected and used in the calculation of the mass consumption.

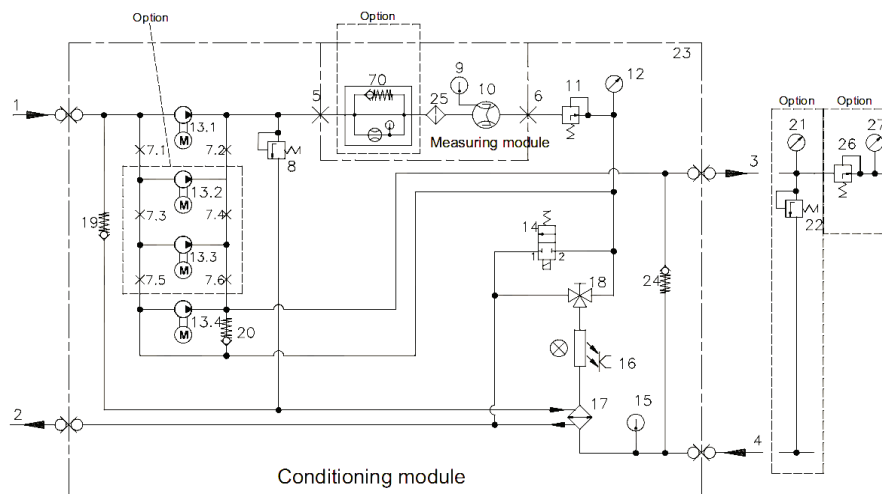

Fig. 4. Block diagram of AVL KMA Mobile [6]

3.3. Flow meter

The pressure differential across a gear meter is controlled to zero by means of an electronic controller and a servo drive. At a pressure differential $\Delta p = 0$ no leaks occur. The gear meter speed then is directly proportional to the flow.

The flow meter consists of the following integrated components (Fig. 5): gear meter, Δp sensor, control electronics, servo drive, interface.

The Δp sensor (Fig. 5, pos. 2) detects the piston position by inductive scanning (Fig. 5, pos. 2.2), which is a measure of the flow when $\Delta p = 0$ between inlet and outlet ports of the flow meter. The position of the piston changes the magnetic flow. In both halves of the measuring coil the piston displacement generates different magnetic resistances. These resistances are evaluated by the following electronics. The output voltage of these electronics is the nominal value for the following servo drive speed control.

The servo drive (Fig. 5, pos. 4) of the gear meter (Fig. 5, pos. 1) consists of a DC motor with gear and flanged HP encoder for speed measurement. This control balances non-linearities and drifting. The system is therefore zero-point stable. Rectangular pulses from the HP encoder, the frequency of which is proportional to the flow, and measurement data are available via a serial interface as output signals.

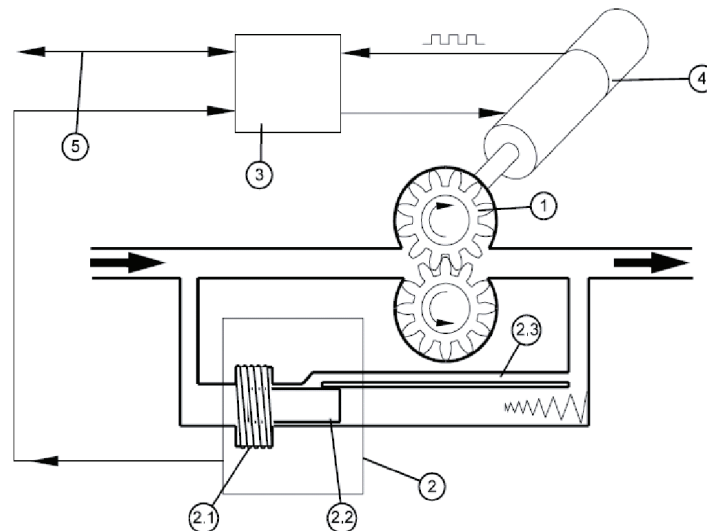

Fig. 5. Measurement principle in KMA Mobile flow meter [6]: 1 – gear meter, 2 – Δp sensor technology, 2.1 – measuring coil, 2.2 – piston, 2.3 – by-pass; 3 – control electronics (external housing), 4 – servo drive, 5 – interface

4. Measurements results

Because with each fuel consumption measurement performed various value were obtained, therefore, in order to prove that the three methods used are equivalent to each other with the variability and the value of the results, the statistical tests were performed on the relative values errors measured compared to the reference value. As the reference method was regarded the fuel consumption measurement using the scale. Hence, the relative error is determined by the formula:

$$R_{iw} = \frac{FC_i - FC_w}{FC_w}, \quad (1)$$

where:

R – relative error of the fuel consumption value relative to the reference value,

i – an index describing the device being compared:

k – KMA Mobile flow meter,

a – AMA i60 exhausts analyzers,

w – an index describing the reference device (PRECISIE 5000D-12000G scale),

FC – mass fuel consumption.

Figure 6 shows the relative error of the mass fuel consumption indications determined by volumetric method using KMA Mobile flow meter and carbon balance method using AMA i60 exhausts analyzers compared to the value determined by gravimetric method using a scale. Mass fuel consumption determined by the carbon balance method was calculated based on the volumetric fuel consumption designated based on the analysis of the exhausts and fuel density measured by KMA Mobile flow meter.

The resulting data was examined for the values that stand out. For this purpose, each data set was subjected to the Grubbs test. For the fuel consumption measurements by carbon balance method there were two values that stood out and were rejected.

Since the fuel consumption were measured with three different devices at the same time, it can be reasonably assumed that the tests conducted represented dependent tests.

To verify whether the compared methods are equivalent with respect to the value of the results, the t-test was carried out for a single trial. If the results obtained by different methods are to give the same result, this means that there should be no difference in the average values obtained by these methods, and thus the relative errors should not be significantly different from zero. Therefore, for the null hypothesis it was adopted that the relative error is equal to 0.

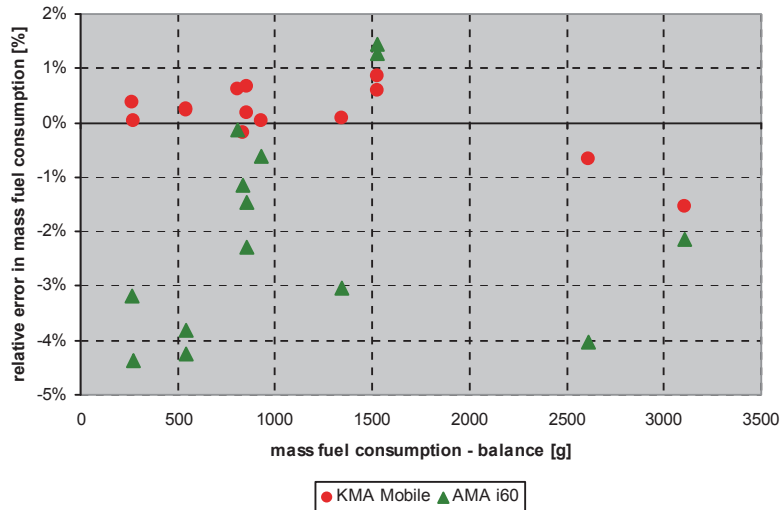

Fig. 6. The relative error of the mass fuel consumption indications measured by KMA Mobile flow meter and AMA i60 exhaust gas analyzers in relation to the value measured by a scale

$$H_0: \bar{R}_{iw} = 0. \tag{2}$$

When performing the t-test for a single trial, we assume that the distributions are normal. In order to check the validity of this assumption the Shapiro Wilk test was performed. The results are shown in Tab. 1 and in Fig. 7. The test results showed that for each pair of devices under consideration (flow meter – the weight, exhausts analyzers – the weight, flow meter – exhausts analyzers) relative error distributions are normal distributions.

Tab. 1. Results of the Shapiro – Wilk test for the R relative error

	KMA – weight	AMA i60 – weight	KMA – AMAi60
Test probability	0.09	0.47	0.87
Significance level	0.05	0.05	0.05
Is the distribution normal?	YES	YES	YES

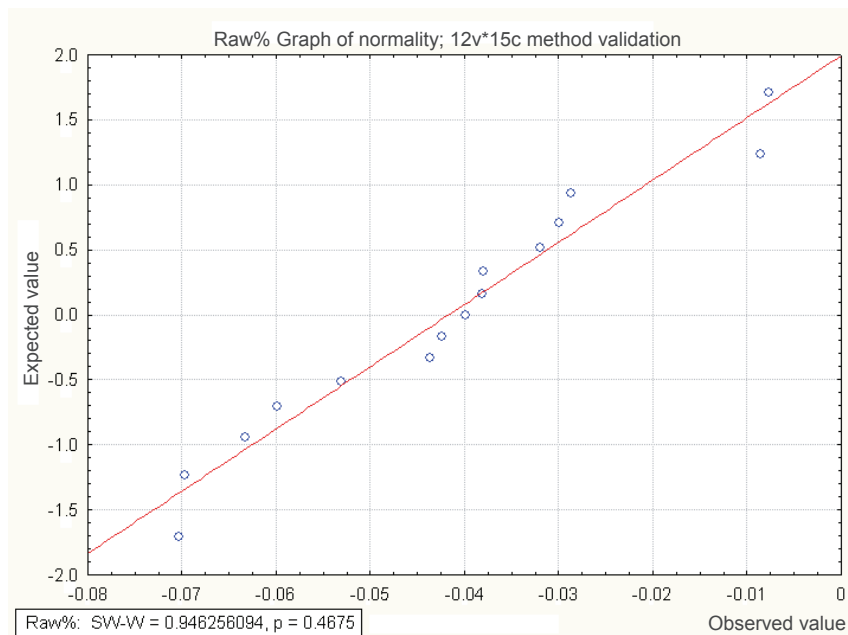

Fig. 7. Normality graph for the relative error of the mass fuel consumption indications measured by AMA i60 exhausts analyzers in respect to the value measured by the scale

Table 2 shows the results of the t-test conducted for a single trial.

Tab. 2. T-test results for a single trial

	Average	Standard deviation	<i>t</i>	<i>p</i>
R_{kw} %	0.001	0.0063	0.5976	0.56
R_{aw} %	-0.040	0.019	-7.8798	0.00
R_{ka} %	0.043	0.018	9.1942	0.00

The t-tests conducted for a single trial showed statistically significant differences in the relative error of the mass fuel consumption indications measured by the carbon balance method and the fuel measured by volumetric and gravimetric methods. Therefore, for these cases, the null hypothesis must be rejected. Based on this it is concluded that using the carbon balance method does not produce equivalent results with the ones obtained by volumetric method using KMA Mobile flow meter and gravimetric method using a scale.

One of the reasons for the differences in the fuel consumption values measured by carbon balance method is an error in the measurement method. Since in this method the exhaust gases are diluted with ambient air, therefore, to calculate the fuel consumption, the corrected concentrations values are used. This correction takes into account the content of the components measured in the diluting air. With this correction the DF dilution factor is calculated, whose formula was derived assuming that the mixture of fuel and air is stoichiometric. This assumption is false for diesel engines that operate at excess air coefficient several times higher than stoichiometric one. Assuming that the actual excess air coefficient is three times higher than the stoichiometric, the concentration of carbon dioxide in the diluted exhausts is 1%, and 0.05% in the diluting air, then relative error in the value of the corrected concentration is about 0.4%.

5. Conclusions

The experiment conducted compared the fuel consumption values measured by three methods: volumetric one using AVL KMA Mobile flow meter, gravimetric using the Precisia 5000D-12000G scale by Swiss Quality Company Medicat Ltd and carbon balance method using a set of AVL AMA i60 analyzers. Statistical analysis showed that the fuel consumption values obtained by the volumetric and gravimetric methods are not statistically different with the $\alpha = 0.05$ significance level, and thus the obtained results of the two methods can be considered equivalent. However, the results obtained using the carbon balance method differ significantly from the values obtained by volumetric and gravimetric methods. On average the relative error of the fuel consumption measurement by the carbon balance method in relation to the other two methods is about 2%.

The reason is the collective error for determining the pollutants mass emission resulting from the error in determining the volume in the CVS collection system, the error of determining concentrations in the samples of diluted exhaust gases and the diluting air, as well as the error of the method of measuring carbon dioxide emissions, resulting from taking into account the adjustment of the carbon dioxide concentration in the atmospheric air, used to dilute the sample.

References

- [1] PN-EN ISO 9000:2005 *Systemy zarządzania jakością. Podstawy i terminologia.*
- [2] Makarewicz, A., Garbarczyk, P., *Postępowanie z metodami badawczymi w laboratorium jako element systemu zapewnienia jakości świadczonych usług*, X Międzynarodowa Konferencja Naukowo-Techniczna: Problematyka normalizacji, jakości i kodyfikacji w aspekcie integracji z NATO i UE cz. III, red. G. Sawicki i A. Świdorski, s. 57–66, ZSJZ, Warszawa 2010.
- [3] *Statystyka w walidacji metod pomiarowych*, Materiały kursowe, StatSoft Polska, 2013.

- [4] *Walidacja, biegłość i inne zagadnienia analizy danych w laboratorium*, StatSoft Polska, Kraków 2011.
- [5] *Fuel Consumption Measurement. AVL KMA Mobile Fuel Measurement System*, Materiały AVL List GmbH.
- [6] *AVL PLU 121 Precision Flowmeter. Operating Instructions. Product Guide*, May 2006 AT2211E, Rev. 00.