

DYNAMIC RESPONSE OF MINE FLAIL STRUCTURE SUBJECTED TO BLAST LOADING

Wiesław Barnat, Paweł Gotowicki, Andrzej Kiczko, Paweł Dybcio

Military University of Technology
Department of Mechanics and Applied Computer Science
Gen. Sylwestra Kaliskiego Street 2, 00-908 Warsaw, Poland
tel.: +48 22 6837201, +48 22 6839947, +48 22 6837221, fax: +48 22 6839355
e-mail: wbarnat@wat.edu.pl, pgotowicki@wat.edu.pl, akiczko@wat.edu.pl, pdybcio@wat.edu.pl

Marcin Szczepaniak, Wiesław Jasiński, Piotr Krysiak

Military Institute of Engineer Technology
Obornicka Street 136, 50-961 Wrocław, Poland
tel.: +48 71 3474440, fax +48 71 3474404
e-mail: krysiak@witi.wroc.pl

Abstract

The paper presents experimental test of mine flail structure designed for a prototype of the Shiba special military vehicle. The Shiba vehicle is equipped with such structure to neutralize mine and IED threats which are one of the most harmful weapons used during modern warfare and peacekeeping missions. The experimental test was performed by the Military Institute of Engineer Technology and the Military University of Technology. The test procedure was based on NATO standards. Detonation of 8 kg TNT AT mine under wheel of the prototype was taken into consideration as a case of possible load during mine clearance operation on the battlefield. The test procedure included deformation measurements of selected parts of mine flail structure. During the tests, strain gauges and camera markers were placed on the structure to allow recording of strains and observation of the specific construction point's movements. The motion was recorded using three high-speed Phantom cameras. Vishay EA-06-120LZ-120 strain gauges with ESAM Traveler bridge with sampling rate 100 kHz were used for strain measurements. The test was performed on military proving ground. As a result, strain versus time plots were obtained. The results were processed using ESAM software. Strain gauges were placed paired in specific structure points. High-speed camera recordings were obtained to visualize the process of structure response. The sequences of selected frames are shown. Pictures of deformed structure are presented.

Keywords: *Improvised Explosive Device (IED), mine flail, demining machine, Shiba*

1. Introduction

Mines and IED charges are one of the most harmful weapons used during modern warfare and peacekeeping missions. Therefore, one of important duties is to detect and neutralize of possible explosive threats. To achieve this goals, special devices must be introduced. This paper presents experimental trials during work on a prototype of the *Shiba* special vehicle with mine flail to neutralise mine and IED threats. Experimental research was preceded by a number of design and construction analyzes. Such investigations were carried out using modern CAD/CAM/CAE systems such as MSC.Patran/Nastran and LS-DYNA using both implicit and explicit methods according to examined load case. The analyzes were performed to design a prototype of mine flail integrated with *Shiba* special vehicle. The usefulness of prototype was evaluated during experimental trials. The test procedure was based on NATO STANAG 4569 [1] and NATO AEP-55 [2] standards. Considered load case is one of possible loads during mine clearance operation on the battlefield according to [3], which is detonation of 8 kg TNT AT mine under wheel of the prototype.

2. Experimental approach

The aim of this study was experimental measurement of deformation of selected mine flail structure elements. The research was conducted in cooperation by the Military University of Technology and the Military Institute of Engineer Technology on the firing ground. Fig. 1 presents the diagram of mine flail and strain gauges attachment points with characteristic dimensions. For the purpose of the research an electroresistance method was used. The equipment consisted of Vishay EA-06-060LZ-120 linear strain gauges with ESAM Traveller CF Signal Conditioner Amplifier System. Strain gauges were placed in pairs on the both sides of the symmetry surface at each part of mine flail. Measure points were placed in the centre of profile walls on their top. The linear strain gauges were aligned with profiles to measure normal deformation in the direction of the profiles axis. As a result of the research, the deformation versus time plots ($\varepsilon - t$) were obtained. Sampling rate was 100 kHz.

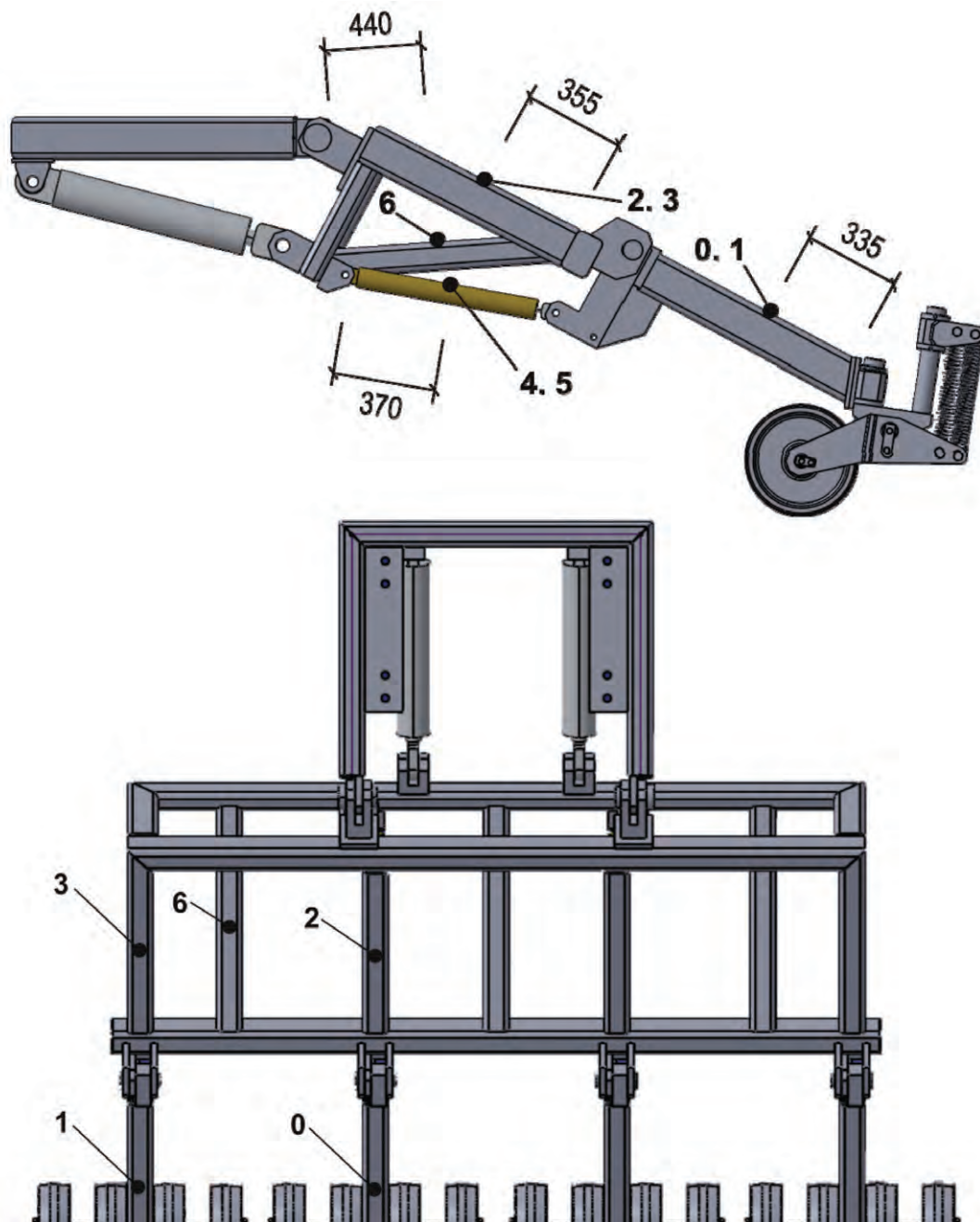

Fig. 1. Diagram of location of the measurement points – dimensions in (mm)

The flail is designed to be used with *Shiba* vehicle, a modular special vehicle for recon and mine sweeping of roads. *Shiba* was developed by Military University of Technology, AMZ Kutno and Military Institute of Engineer Technology. Presented solution is an answer to growing threat from improvised explosive devices (IEDs) to soldiers during peacekeeping missions. Due to great variety of explosive types and sizes, it is crucial to develop solution allowing recognition, evaluation and neutralization of potential threats. The *Shiba* family consists of three vehicles:

- with ground penetrating radar and metal detector for recon,
- with mine flail for mine clearance and path marking,
- technical vehicle with interrogation arm.

3. Test results

The test programme included deformation measurements of selected parts of mine flail structure. However, the test stand consisted of mine flail attached to the subframe loaded with weight of 26.7 kN. Fig. 2 shows the *Shiba* vehicle with mine flail. For the purpose of this study 8 kg of TNT were used. The charge consisted of 20 packages 400 g each. The charge was placed under of the centre wheel next to “0” strain gauge shown in Fig. 1. The position of explosive is shown in Fig. 3.



Fig. 2. The Shiba military vehicle



Fig. 3. Explosive charges placed under the wheel of mine flail

As previously mentioned, explosive test was recorded using high-speed Phantom V12 camera. During study, sampling rate of 10 000 frames per second was used. Both cameras were triggered by explosive igniter. Fig. 4 and Fig. 5 presents subsequent selected frames of recorded images during the firing ground. In Fig. 5 there is clearly visible detonation front spherical propagation.

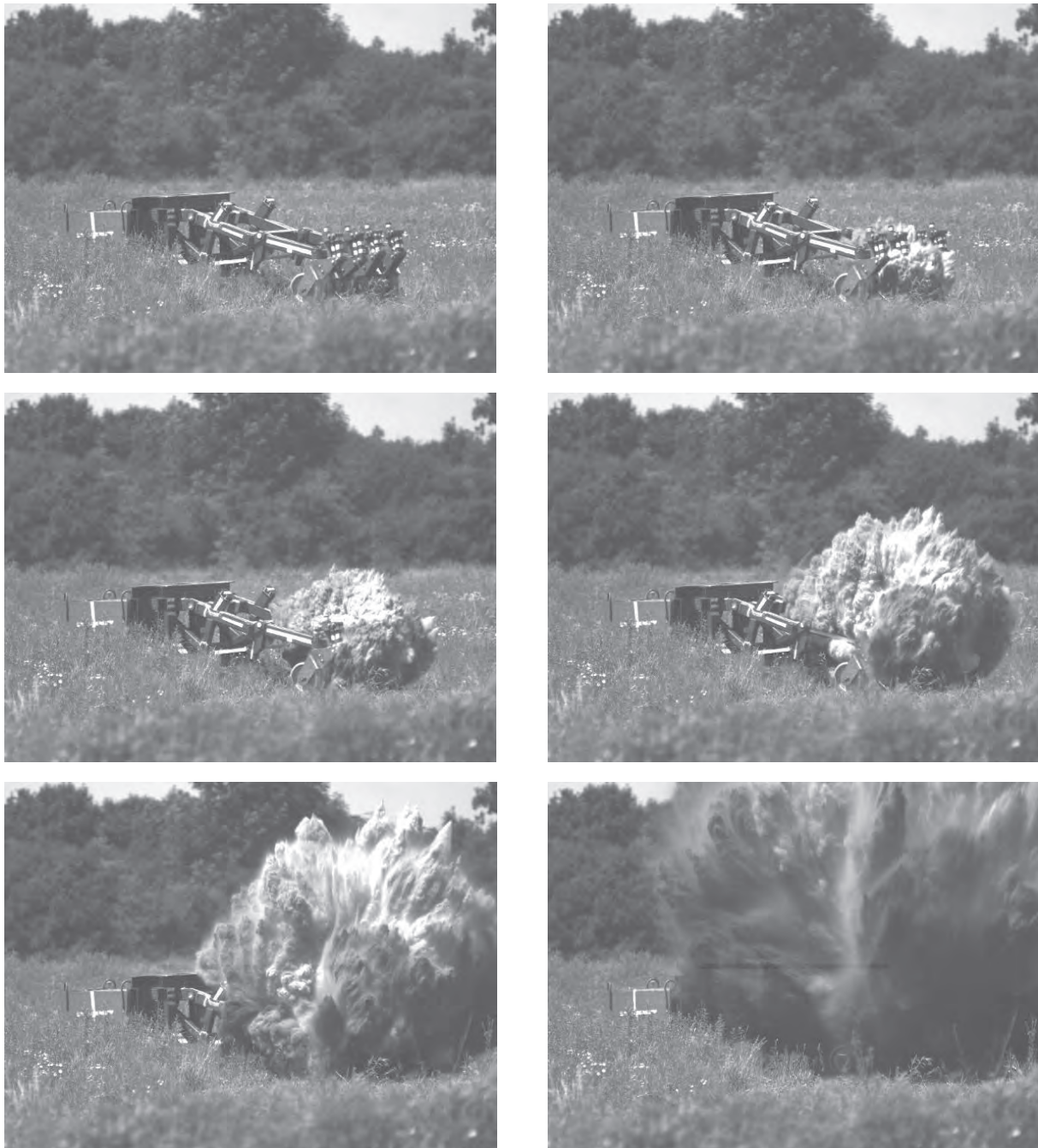

Fig. 4. Images recorded during the test using high-speed camera No. 1

After the tests, static photographs of deformed structure were taken in order to verify numerical models used in prototype design phase. Fig. 6 shows examined mine flail before and after test. There are visible deformed parts of the structure. What is more, some parts were separated due to blast and were thrown within 25 m radius. Examination of destroyed parts also showed, that proper welding technique is relevant for mine flail structure. Despite the deformation of flail structure and separation of centre tandem wheels, the support frame did not receive such severe damage. This leads to conclusion that the dynamic impulse transferred to the *Shiba* vehicle will be significantly



Fig. 5. Images recorded during the test using high-speed camera No. 2



Fig. 6. Mine flail after detonation

lower. What is more, weight used to simulate vehicle's front part was only 3 tons. Entire vehicle weights around 10 tons. Basing on the performance of prototype some design changes will be introduced i.e. change of welding technique for flail structure attachments and profile dimensions for wheel tandems. After introduction of changes the flail will be attached to the *Shiba* vehicle and overall performance will be evaluated.

As well as video images, strains in specified structure points were measured. Fig. 7 to 13 present the values of strains for measurement points 1 to 6 which were recorded. On the plots strains are in $\mu\text{m}/\text{m}$ (*microstrain*). The plots of recorded $\varepsilon - t$ are 5 point averages of bulk results.

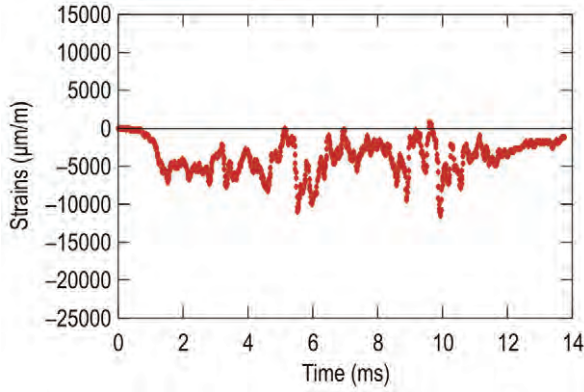

Fig. 7. Plot of $\epsilon - t$ for the measurement point "0"

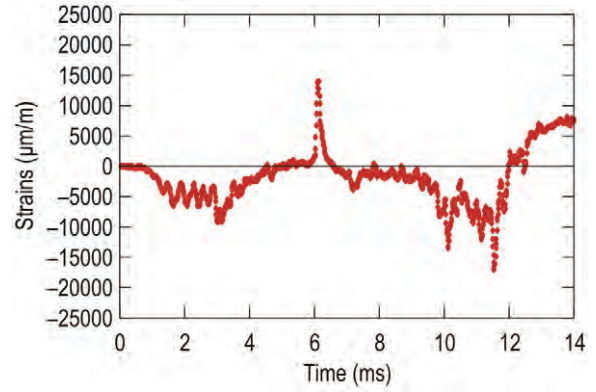

Fig. 8. Plot of $\epsilon - t$ for the measurement point "1"

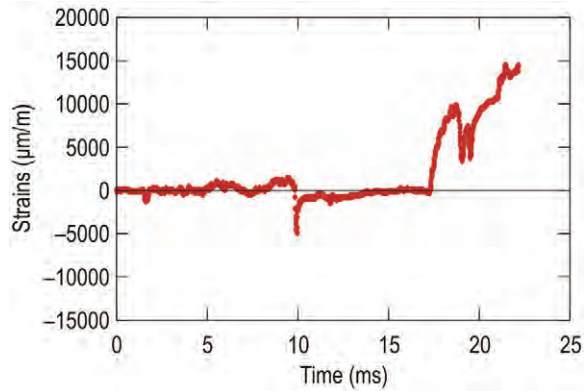

Fig. 9. Plot of $\epsilon - t$ for the measurement point "2"

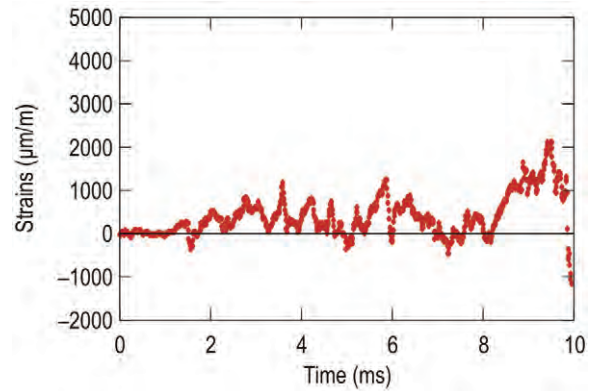

Fig. 10. Plot of $\epsilon - t$ for the measurement point "3"

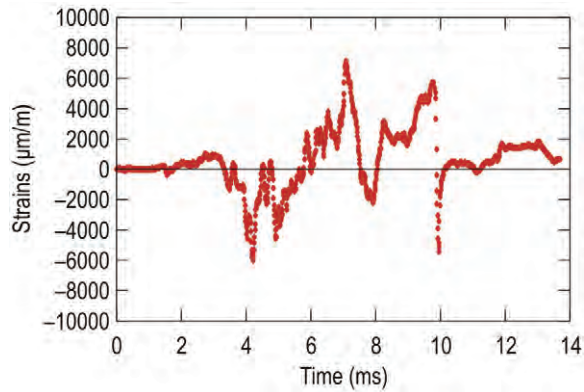

Fig. 11. Plot of $\epsilon - t$ for the measurement point "4"

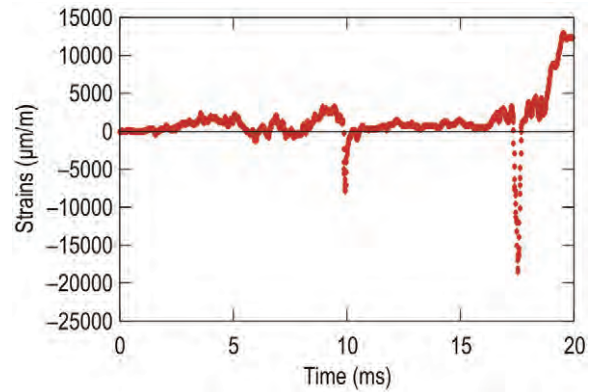

Fig. 12. Plot of $\epsilon - t$ for the measurement point "5"

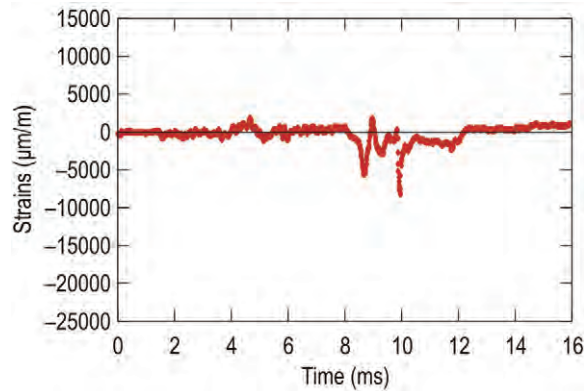

Fig. 13. Plot of $\epsilon - t$ for the measurement point "6"

It is clearly visible that the deformation caused great strains in each flail's component leading to its destruction. There are some peak values that indicate open or closed circuit which signals damage of gauges or wiring which is the limitation of used method. The most accurate results were obtained for first 10 ms of the test.

4. Conclusions.

The article presents the results of experimental tests which were used to validate the numerical models used for design of mine flail special device. The main problem during designing of structures loaded with pressure impulse is appropriate modelling of phenomena's physics. The obtained results are sufficient for verification and validation of numerical model, however, to fully visualize the process some modifications should be introduced.

The strain gauges methods can be efficiently used to measure strains in dynamically loaded construction. The advantage of this method is a relatively low price of gauges, which are destroyed during the tests. The limitation is physical breakdown of sensors or wiring due to blast wave. Despite that, the experimental results are very important because they allow validation of results obtained from numerical experiments.

During the explosive tests, the sequences of frames recorded by high speed cameras can be used only for initial time. Later on, gases and pollutions coming from the ground reduce visibility. To overcome this problems, special kind of explosive and proper preparation of test stand base are needed.

The experimental investigation of this type of constructions are expensive and required a lot of time to do the preparations. The further development of construction will be strongly supported by calculations using FEM method. This will allow cost reduction and verification of many possible options to choose the best one.

References

- [1] STANAG 2920, *The Adoption of Standards for Ballistic Protection Levels and Testing*, NATO Standardization Agency, Brussels, Belgium 2003.
- [2] NATO AEP-55, *Procedures for Evaluating the Protection Levels of Logistic and Light Armoured Vehicles for KE and Artillery Threats*, NATO Standardization Agency, Brussels, Belgium 2003.
- [3] MIL-STD-662F, *Military Standard: V50 Ballistic Test For Armor*, 1997.

