

## MEASUREMENTS OF LAPPING PLATE TEMPERATURE

Justyna Molenda, Adam Charchalis

Gdynia Maritime University, Faculty of Marine Engineering  
Morska Street 81-87, 81-225 Gdynia, Poland  
tel.: +48 58 6901549, fax: +48 58 6901399  
e-mail: jmolenda@am.gdynia.pl, achar@am.gdynia.pl

### Abstract

Lapping process is commonly used for ultra-precision machining of various materials. An essential role during lapping plays flatness of the wheel-working surface because workpiece surface takes mirror image of it. Due to its applications requiring extreme size accuracy, straightness and concentricity, it is very important that working surface remains flat in the course of machining.

Getting out of flatness can be caused by uneven wear or heating. To prevent nonuniform wear of lapping plate surface, conditioning rings should be suited appropriate. Lapping machines producers and researchers make recommendations about proper rings position during machining. To provide constant temperature of the wheel, cooling systems are applied in modern machines, but not in all of them. Therefore, wheel temperature problem is significant one, and it should be known.

This paper presents results of authors work on choosing proper measurement method of lapping plate temperature. During lapping process wheel is rotating. Maximum velocity value for ABRALAP 380 lapping machine is 65 rev/min.

Mainly for this reason, contactless infrared method was selected. Because getting an accurate temperature of an object using this method is difficult, during experiments temperature rise not exact value were analysed. There were also presented results of experiments which goal was to find lap plate emissivity.

**Keywords:** flat lapping, lapping wheel temperature, material removal rate, surface roughness

### 1. Introduction

The finishing processes are an important perspective to be considered today to meet the goals like parallelism, tolerances, flatness and smooth surface of workpieces. These processes are high-precision abrasive processes used to generate surfaces of desired characteristic such as geometry, form, tolerances, surface integrity and roughness characteristics. A leading importance in this perspective has the lapping process. It leads to a surface with low roughness and high precision. The topographical structure resulting from lapping is very advantageous in sliding joints, because of the high ability of lubricant retention, as well as in nonsliding joints because of the high load-carrying ability. Lapping process is used in a wide range of applications and industries. Typical examples of the processed components are pump parts, transmission equipment, cutting tools, hydraulic and pneumatic, aerospace parts, inspections equipment, stamping and forging [3, 4, 7].

The machining methods used in lapping operations can be classified as:

- single-side flat lapping,
- double-side flat lapping,
- cylindrical lapping between laps,
- lapping with bonded abrasives.

Single-side lapping is the most extensively used type of lapping process. Its goal is to achieve extremely high flatness of the workpiece and/or close parallelism of double-lapped faces. The other applications include removal of damaged surface and sub-surface layers and, enhancement of the surface finish on workpieces. The advantages of this type of lapping is that many pieces can be machined at one time and besides this, work holding is very simple, cut rates are consistent, and close accuracies are inherent with the process [2, 4, 8, 10].

## 2. Processing principles of flat lapping

The machines used in one side lapping consist of one or more lapping plates (1) on which conditioning rings (2) are placed to hold the workpieces (3) (Fig. 1).

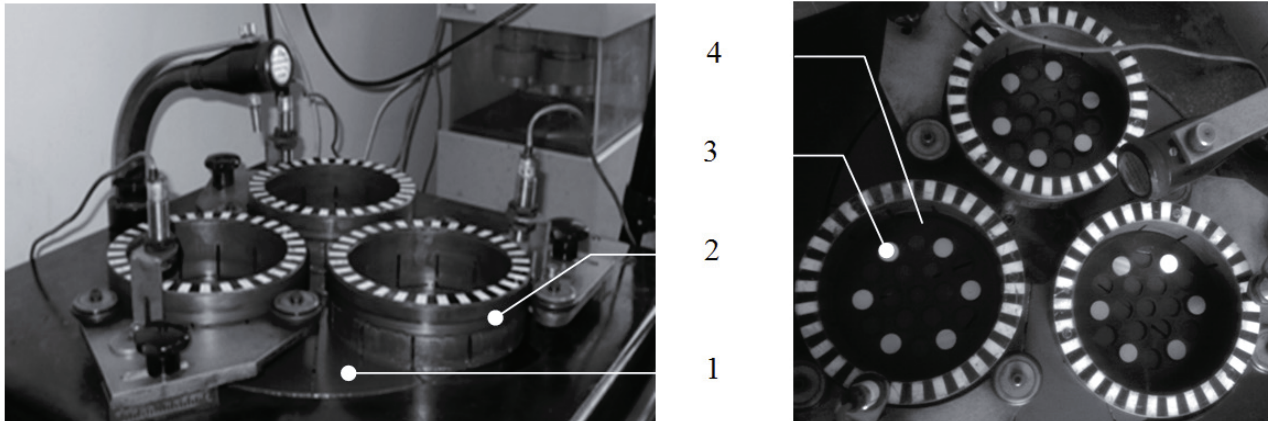

Fig. 1. Executory system of single-side lapping machine

Parts are arranged in the respective work holders (4) directly on the wheel surface. Then load is applied (by means of load positioned on the top of the workpiece). Lapping is a load-controlled process, which means that the load on the lap is the parameter which value is controlled by keeping in mind the material of the workpiece, material of the lap plate, stock removal rate and the desired surface finish. Lapping is a loose abrasive machining process that uses abrasive particles combined within an oil or aqueous medium depending on the material being finished. The abrasive slurry is applied to the surface of the lap continuously or at specific intervals to form an abrasive film between the lapping plate and the parts to be lapped. When load is applied, it is transferred to the workpiece where the abrasives grains make contact between the tool and the part, and because tool is a rigid one, high stresses are applied to the sample causing material removal. Each loose abrasive particle that meets the surface of the part acts as a microscopic cutting tool that makes either an indentation or cause the material to cut away very small particles. When lap plate is given some velocity that should be low enough to do the machining, parts are rotated mechanically or frictionally in numerous motions and removal occur over the entire surface.

Abrasive processes have a large number of parameters that can be varied in order to obtain the desired process output. The lapping process is influenced by load, rotation of the lapping plate, material of the lapping plate, lapping time, type of slurry used, grain size of the abrasive, flow rate, slurry concentration, etc. Tough many years of studies, there is still a lack of a systematic understanding of the process, fine-tuning or developing processes for a new product has always been an empirical process with success dependent upon the skill of the machine operator or engineer. Thus, the operator needs to stop the process continually to measure the results to guarantee that the workpieces will reach the required tolerances.

Fundamentally, benefits and effects of the lapping process must be studied, shedding light on the scientific basis that transforms lapping from art to engineering [1, 3-5, 7].

## 3. Lapping wheel temperature

Since the parts will take a mirror image of the wheel surface, the key to the operation of free-abrasive machining, like lapping, is the flatness of the wheel. It is the most influential and deciding factor to the processing accuracy of the workpieces. Undesirable deviation of lapping tool flatness can be caused by its uneven wear or heating.

As the workpieces, the tool is also formed during the process. Abrasive grains are held by the facing workpieces, and they simultaneously scratch the plate surface as a reciprocal behaviour. This causes profile wear of lap plate. With the increase of the lapping time surface flatness of the lapping plate deteriorates, requires reconditioning. Reconditioning is normally done by removing the lapping plate from the machine, whose surface is then ground or lapped, or by placing a conditioning ring on the lapping plate to recondition the plate (Fig. 2). In order to recondition the plate that is dented (Fig. 2a); conditioning rings are placed slightly toward the edge of the plate and run while lapping slurry is being supplied onto the plate. When the lapping plate has become convex (Fig. 2b), the conditioning rings should be placed slightly toward the centre. Next to lapping machines producers recommendations about it, there are also mathematical models in the published literature [4, 6, 8, 10].

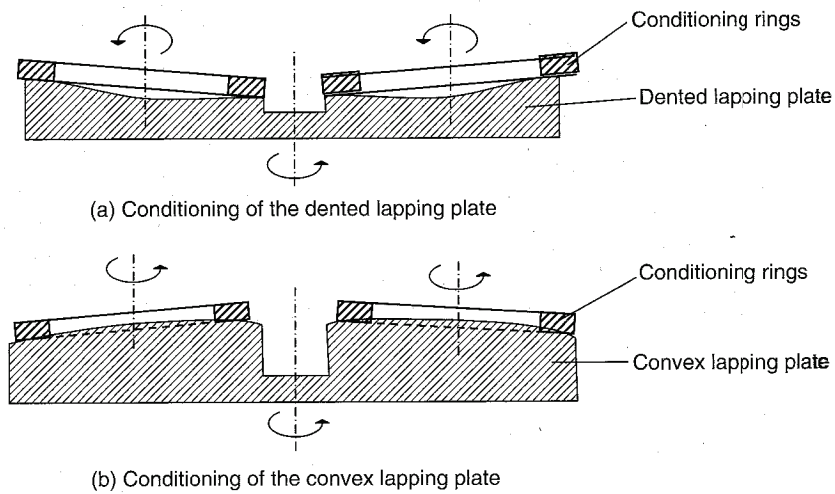

Fig. 2. Conditioning methods of the lapping plate with a conditioning rings [4]

Hence, to reduce workpieces flatness deviations, constant wear and temperature of the wheel should be provided. Temperature change caused by the friction heat generated during the lapping and environmental temperatures also affects the shape accuracy of the lapping plate. As the friction heat from the long run lapping in particular deforms the lapping plate and degrades its flatness, it is essential to cool the plate down during the lapping in order to keep the plate to a certain temperature. Cooling the lapping plate prevents its shape accuracy from deterioration to be caused by the heat deformation of the lapping plate during the lapping. Most of today produced lapping machines have devices to carry away the heat generated during the process or to control lap plate temperature. It could be water-cooled system built in the plate (Fig. 3) or temperature control system or both [1, 4, 6, 8].

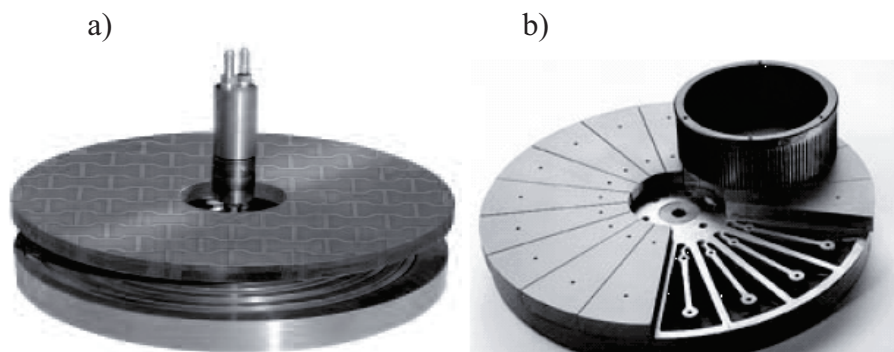

Fig. 3. Water-cooled wheels: a) manufactured by LAMPLAN, b) manufactured by PETER WOLTERS [8, 10]

Despite the technical solutions exist, the problem was not widely analysed by researchers. There are only few works in the published literature about lapping temperature. In previous tests, researchers usually neglected the influence of temperature rise on lapping results and assumed that lapping is low temperature process. Meanwhile problem of executory system elements heating is important because of high demands for lapped elements accuracy and because of enabling their wider automated dimension control during mass production. While machining workpieces heating up to temperature of executory system elements and therefore need cooling to normal temperature before measurements, what extending machining time. The experiments were executed to check how fast workpieces heat up to the temperature of executory system elements.

#### 4. Technique of wheel temperature measuring

To measure the temperature of lapping wheel noncontact infrared method were chosen. This was mainly due to thermography ability to catching moving targets in real time, to measure temperatures over a large area. As a result of a measurement, it is obtained a data set that is presented in a form of a colour map: a thermogram. Because getting an accurate temperature of an object using this method is difficult, during experiments temperature rise were analysed.

For measuring the temperature, infrared camera ThermoGear G100 produced by NEC Avio Infrared Technologies CO., Ltd. was used. The camera does not need computer to be controlled. It employs a gun grip design with a rotatable monitor similar to that of video cameras, which enables one-hand operation. Two measuring ranges are defined: -40-120 and 0-500 °C. The measurement accuracy is  $\pm 2$  °C or 2% of reading, whichever is greater. The thermogram consists of 76800 measuring points (320 points in 240 lines). The image capture support functions of a 2-megapixel visible camera. Images that have been made can be presented as thermal (Fig. 4a), visible (Fig. 4b), parallel (Fig. 4c) or as a mix of both (Fig. 4d) [9].

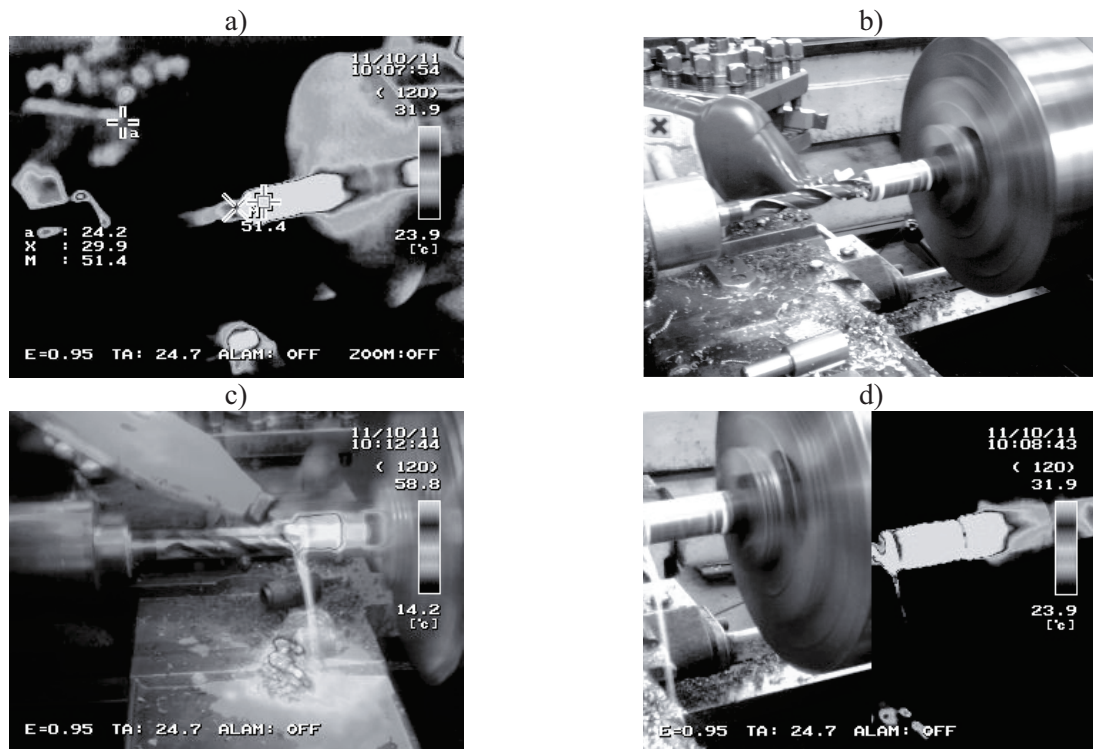

Fig. 4. Displaying images: a) only thermal, b) only visible, c) both parallel, d) mix of both

When using infrared camera for measuring lap plate temperature it is possible to determine its value in any of 76800 points over wheel surface. To analyse the results, computer software InfReC



Analyser NS9500 Lite generate Excel file report with temperature value for each point. An exemplary thermogram is depicted on Fig. 5.

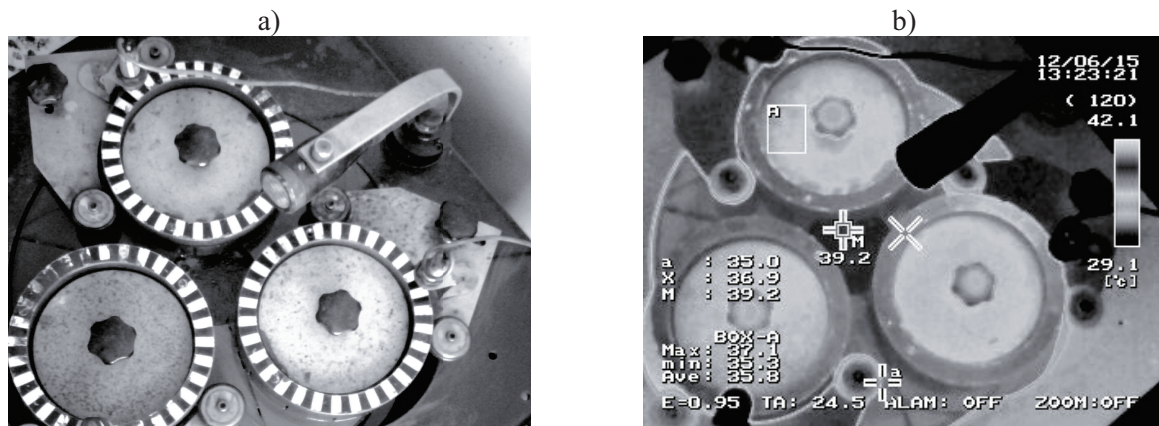

Fig. 5. ABRALAP 380 executory system: a) photo camera view, b) the thermographic camera view

To assure accurate noncontact infrared temperature measurement there is a need to keep in mind several factors, including determining appropriate value of emissivity. The last can be done in various ways. First, emissivity of many frequently used materials can be found in a table. Particularly in the case of metals, the values in such tables should only be used for orientation purposes since the condition of the surface (e.g. polished, oxidized or scaled) can influence emissivity more than the various materials themselves.

The emissivity of a particular material, cast iron in this case, can be determined during experiment by different methods. Method chosen by authors involved heating up the wheel to a known temperature, measured with high accuracy with use of contact thermometer and then measuring the target temperature with the infrared camera. The next step was changing the emissivity in infrared camera until the temperature corresponds to that of the contact thermometer. Emissivity value determined this way could be used for all noncontact measurements of lap plate temperature.

According to table, cast iron emissivity in temperature 50°C is about 0.81. To determine the exact value of lapping plate emissivity tests were done.

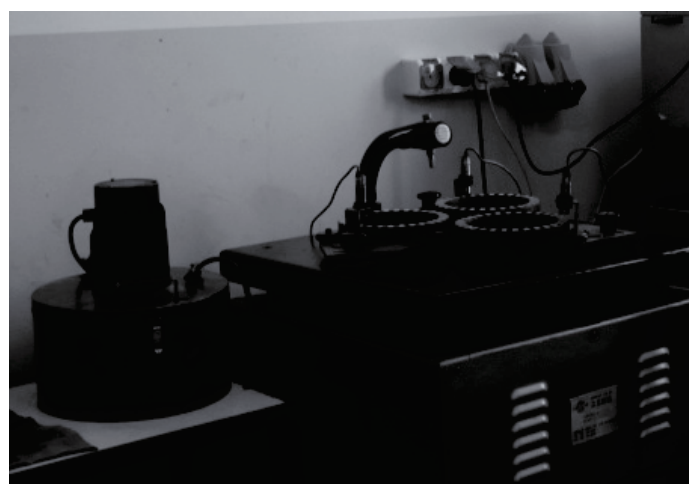

Fig. 6. One-plate lapping machine ABRALAP 380

For contact temperature measurements thermometer TES1312 Dual K-Type was used. The experiments were carried out on a plate-lapping machine ABRALAP 380 with a grooved cast-iron lapping plate and three conditioning rings (Fig. 6).

Measurements were taken during machine working with all three rings and without lapping material. A constant supply of the slurry was maintained using the abrasive feed mechanism to provide a fresh supply of abrasive grains into the work zone. The supply of the slurry was maintained at  $19 \cdot 10^{-8} \text{ m}^3/\text{s}$ . It was composed of silicon carbide grains F400/17 mixed with kerosene and machine oil in the ratio of one part of abrasive to six part of fluid (53% kerosene and 47% oil) by weight. The wheel velocity had maximum value i.e. 65 rev/min.

The determined emissivity was equal 0.95 and was bigger than value from the table, as was expected. During lapping wheel surface is very dark due to charging and covering the waste slurry what increases emissivity value.

## 5. Conclusions

Lapping plate temperature is a significant factor influencing workpieces flatness and accuracy. Hence, measurements of its temperature and temperature distribution over its surface should be investigated. For that purpose, special attention should be taken to the choice of measuring method. In this work, authors propose infrared methods, which allow for contactless measurements. This is important due to lapping plate movement during machining. To avoid excessive errors during exact temperature value determination, temperature rise should be analysed.

## References

- [1] Agbaraji, C., Raman, S., *Basic observations in the flat lapping of aluminum and steels using standard abrasives*, International Journal of Advanced Manufacturing Technology, No. 44, pp. 293-305, 2009.
- [2] Crichigno, Filho, J. M., Teixeira, C. R., Valentina, L. V. O. D., *An investigation of acoustic emission to monitoring flat lapping with non-replenished slurry*, International Journal of Advanced Manufacturing Technology. No. 33, pp. 730-737, 2007.
- [3] Horng, J. H., Jeng, Y. R., Chen, C. L., *A model for temperature rise of polishing process considering effects of polishing pad and abrasive*, Transactions of ASME, Vol. 126, pp. 422-429, 2004.
- [4] Marinescu, I. D., Uhlmann, E., Doi, T. K., *Handbook of lapping and polishing*, CRC Press Taylor & Francis Group, Boca Raton, 2007.
- [5] Molenda, J., Barylski, A., *Determining the conditions for temperature measurements during flat lapping*, Journal of KONES Powertrain and Transport, Vol. 18, No. 3, pp. 293-297, 2011.
- [6] Molenda, J., Charchalis, A., Barylski, A., *The influence of abrasive machine on temperature during one side lapping*, Journal of KONES Powertrain and Transport, Vol. 17, No. 2, pp. 357-362, 2010.
- [7] Molenda, J., Charchalis, A., Barylski, A., *The influence of workpiece hardness on plate temperature during one side lapping*, Solid State Phenomena, Trans Tech Publications, Switzerland, Mechatronic Systems and Materials V, pp. 194-199, 2013.
- [8] Information on [www.lappingmachines.com](http://www.lappingmachines.com).
- [9] Information on [www.nec-avio.co.jp](http://www.nec-avio.co.jp).
- [10] Information on [www.peter-wolters.com](http://www.peter-wolters.com).