

Original article

Hazards and their reduction in urea production for synthesis reactor by Mitsui - Toatsu technology

Aleksander Wyciszkievicz^{1*}, Krzysztof Golacki², Waldemar Samociuk³

¹Faculty of Production Engineering, University of Life Sciences in Lublin, Poland
aleksanderwyciszkievicz@wp.pl

²Faculty of Production Engineering, University of Life Sciences in Lublin, Poland
krzysztof.golacki@up.lublin.pl

³Faculty of Production Engineering, University of Life Sciences in Lublin, Poland
waldemar.samociuk@up.lublin.pl

INFORMATIONS

Article history:

Submitted: 20 June 2017

Accepted: 11 November 2017

Published: 15 March 2018

ABSTRACT

Industrial large-scale urea production creates a number of hazards due to equipment and machine failures as well as service errors. Failures can cause material, environmental and human losses. The work presents the assessment of safety hazards and failure effects for selected emergency scenarios of Mitsui - Toatsu's urea synthesis reactor. A fragment of the process implemented in the synthesis node was covered by HAZOP (Hazard and Operability Study), and the critical points, from the security point of view, were identified. Several emergency scenarios for various types of failures and various effects are presented. The analyzed contingency scenarios include: blocking the valve on the outflow from the reactor and leaks caused by corrosion resulting from the maintenance of improper technological parameters of the process. The work suggested the need for new security measures and modernization of the installation by using the safety function for the selected critical point. The hazards analyzed and the contingency scenarios developed are essential for risk assessment and its possible reduction.

* Corresponding author

KEYWORDS

HAZOP hazard analysis, contingency scenarios, safety function, urea synthesis



© 2018 by SJMULF. This is an open access article under the Creative Commons Attribution International License (CC BY). <http://creativecommons.org/licenses/by/4.0/>

1. Introduction

Urea as nitrogen fertilizer (46% N) is commonly used in solid and liquid form by plant producers. In recent times, due to high demand, its production is gradually increasing. It currently stands at over 152 million tons a year. In addition to its use as a fertilizer, urea is also a raw material for the production of melamine and urea-formaldehyde resins and adhesives. Urea is also widely used in the process of a selective catalytic reduc-

tion for exhausts purification. A certain proportion of urea is also used as an additive for cattle feed [1, 2].

The industrial urea synthesis consists in the reaction of ammonia with carbon dioxide under high-pressure conditions, which can be summarized as:



There are two stages in the process:

- formation of ammonium carbamate;



- dehydration of ammonium carbamate to urea.



The reaction of carbamate production is rapid, exothermic and in the conditions of reactions used in the industry is practically completed to the end [1, 2].

The carbamate dehydration reaction is slower and endothermic, and is not complete. The conversion of CO₂ (into urea) takes place in the range of 50% to 80%. It grows with the increase of temperature and the NH₃/CO₂ ratio and decreases with the increasing H₂O/CO₂ ratio. The urea solution from the synthesis / recirculation stage of this process is concentrated to the urea melt in order to convert it into a solid product in the form of tower or mechanical granulated products. Improving the urea production technology focuses on increasing the efficiency of separation of urea from the remaining components of the liquid-gas mixture leaving the reactor, and recovering the excess of ammonia and ammonium carbamate in order to recycle ammonia and carbon dioxide. Particular attention is also paid to the development of materials resistant to corrosion resulting from the contact with the carbamate solution as well as the optimization of thermal and energy balances [1, 8]. Hitherto improvements to the process technology have largely focused on lowering production costs and minimizing negative impacts on the environment. These enhancements included, inter alia, increasing the efficiency of CO₂ conversion; improving heat recovery; reducing the consumption of energy media; recovering residual NH₃ and urea from wastewater.

Modernization of installations should always be preceded by a hazard analysis, and consequently, making changes so as to reduce unacceptable risk [1, 2, 8].

2. The characteristics of the object

The installation for the production of urea is a complex object, occupying a large space. This paper focuses on the analysis of the reactor and the accompanying apparatus and equipment, which play a key role in the urea production. Figure 1 shows the part of the installation for which emergency events were analyzed. The installation for the urea production has a nominal capacity of 500 t/d. The final product is the 75% urea solution. The consumption of raw materials: CO₂ - about 4000 Nm³/h; liquid ammonia - approx. 12 t/h; the circulating solution - approximately 13 m³/h.

1.1. Urea production by Mitsui-Toatsu technology

The urea solution production process is continuous in four phases:

- the phase of urea synthesis (synthesis);
- the phase of separation of unreacted raw materials (decomposition-expansion);
- the phase of aqueous urea solution processing (evaporation);
- the phase of recovering unreacted raw materials (absorption and condensation of ammonia).

The individual production phases in the synthesis and recirculation section are characterized by similar unit processes that result in qualitative and quantitative changes in the mass stream. In the first phase of the production, urea is synthesized from raw materials. After compressing the raw materials (carbon dioxide, ammonia and circulating solution) to 21 MPa and having them mixed, a chemical reaction takes place in the reactor at about 195°C and the time of the reagents' residence in the synthesis reactor is about 30 min. The molar ratio of the reagents is $\text{NH}_3:\text{CO}_2=3.7$; $\text{H}_2\text{O}:\text{CO}_2=0.5$. The post-reaction mixture contains about 34% of urea. Ammonium carbamate, ammonia, carbon dioxide and water make up the rest. In the next phase of the process the post-reaction mixture is subjected to a four-stage expansion from the 21 MPa (in the reactor), successively to 3500; 1800; 200 and 0.3 kPa pressure. During each expansion stage the solution is simultaneously diaphragmatically heated for two purposes. Firstly, ammonium carbamate should be decomposed into ammonia and carbon dioxide. Secondly, the solution should be concentrated through evaporation of ammonia, carbon dioxide and water. The above processes are carried out at temperatures lower than in the reactor, i.e. the temperature decreases from about 150°C to 120°C and the pressure decreases accordingly from 3.5 MPa to 300 hPa and for individual decomposition stages. As a result of these processes the urea solution of about 75% and a mixture of NH_3 , CO_2 and H_2O gases are obtained. The urea solution is sent for further processing, resulting in the final product - granular urea, while the gases are condensed and absorbed in order to recover unreacted raw materials. Unreacted raw materials are reintroduced into the urea synthesis reactor in the form of a circulation solution. The recovery of unreacted raw materials (stripped gases) is carried out in the condensation-absorption process, which takes place in the absorption columns. Remnants of non-concentrated ammonia are absorbed in the process water at an elevated pressure of about 1.5 MPa. The ammonia water so obtained is used in the absorption of the stripped gases.

1.1.1. Description of the process in the chemical reactor

The reaction of urea synthesis proceeds in the synthesis reactor, where raw materials: gaseous carbon dioxide, liquid ammonia and the circulating solution "RC" are delivered.

Carbon dioxide after passing through the separator (where H_2 and H_2S are separated from it) is sucked in by the compressor and compressed to 23 MPa. The compressed

carbon dioxide is heated so it should be cooled in a water cooler to about 40°C. It is then fed into the synthesis reactor.

Liquid ammonia taken from the storage tank by means of a liquid ammonia pump is compressed to a pressure of 23 MPa. After compression and before being fed to the synthesis reactor, it is heated with superheated steam to a temperature of about 100°C in ammonia preheaters. This completes the heat needed for the urea synthesis and indirectly regulates the temperature in the synthesis reactor.

A circulation solution obtained in the last section of the installation, the absorption section, is also introduced into the synthesis reactor. This solution is forced into the synthesis reactor using a piston pump. The amount of the solution fed to the synthesis reactor depends on the operating conditions.

1.1.2. Characteristics of nodes and individual elements cooperating with the reactor

Check valves are fitted on the pipelines of carbon dioxide, liquid ammonia and circulation solution, before the entry to the synthesis reactor, to prevent the backflow of the reaction mixture from the reactor to the feeding pipelines. Check valves have process water injectors to prevent crystallization of the solution. Carbon dioxide compressors and piston pumps are equipped with safety valves protecting against excessive pressure surge. Safety valves that protect the synthesis reactor and ammonia preheaters from adverse effects of pressure surge are fitted behind ammonia preheaters on the pipelines of the circulation solution from the RC pump (Figure 1) and the ammonia pipeline from the ammonia pump. The pipeline transporting the reaction mixture from the synthesis reactor to the expander is provided with a safety plate. The safety plate protects the pipeline from bursting if the maximum permissible pressure is exceeded.

1.2. Characteristics of the media posing a threat

1.2.1. Ammonia

Ammonia (NH₃) is the basic raw material in the chemical industry, used to produce fertilizers, nitric acid, synthetic resins, etc. and as a cooling medium (direct and indirect cooling) [4]. Ammonia is a poisonous, corrosive, toxic, combustible and dangerous substance for the environment. In the gas form it is colorless, with characteristic sharp, suffocating odor, well soluble in water. Ammonia gas is lighter than air (the density of ammonia under normal conditions is 0.771 g/dm³ and at the boiling point of 0.682 g/dm³). Its melting point is -77.7°C, the boiling point - 33.4°C and the flash point - 720°C. It burns with a yellowish flame into nitrogen and water. Above 700°C ammonia has strong reducing properties, which is due to its thermal decomposition with hydrogen release. The maximum admissible concentration of ammonia at a workplace is 14 mg/m³ (19.74 ppm), while the maximum admissible momentary concentration - 28 mg/m³ (39.48 ppm). Ammonia is not classified as a flammable substance and is not burned in a free space without a foreign ignition source. Ammonia is classified in the B2 group (low flammability) by ASHRAE (American Society of Heating, Refrigerating

and Air Conditioning Engineers). In closed rooms, ammonia can burn on the assumption that its concentration (volume) is about 20%. A fire takes only a few seconds in rooms with a high concentration of 15 to 28%, as oxygen is consumed quickly. A fire can be avoided by adhering to the principle of proper ventilation of a room with ammonia equipment so as to prevent combustion. The presence of electrical equipment has not yet caused a fire of rooms containing ammonia.

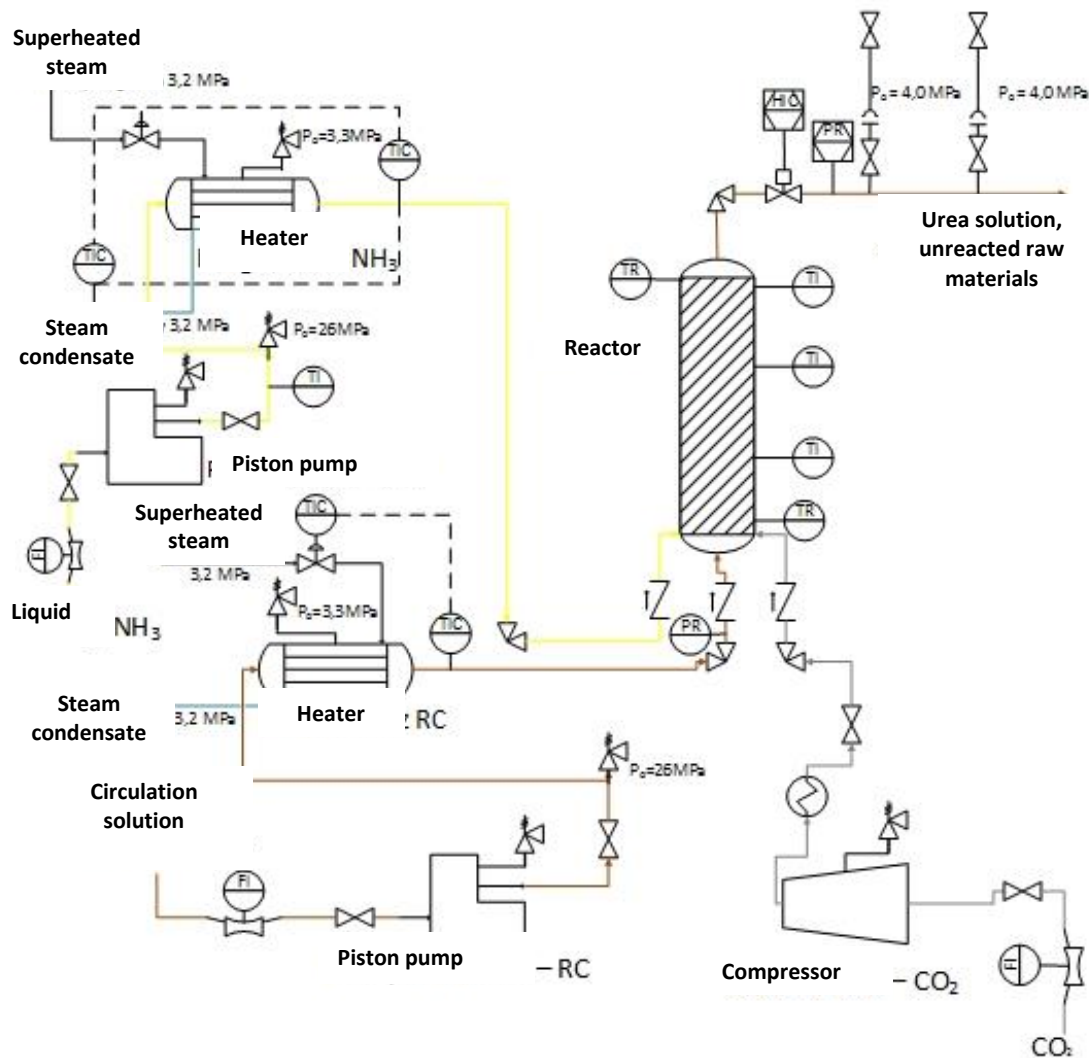

Fig. 1. Fragment of installation for urea production: Reactor and devices preparing the input media for the process

Source: own elaboration

1.2.2. Carbon dioxide – CO₂ (gaseous)

Carbon dioxide in the gaseous state occurs in large quantities under various pressures, mainly in a compressor room. In carbon dioxide compressors the pressure varies from 0.05 bar at suction at the 25 MPa discharge pressure. Carbon dioxide is heavier than

air (the normal density of CO₂ is 1.96 kg/m³ at 20°C). This poses a particular threat to workers controlling equipment, fittings and a system of piping close to ground or canals. Its melting point is - 56.5°C and the boiling point - 78.55°C. The maximum admissible concentration at a workplace is 9000 mg/m³ and the maximum admissible momentary concentration is 27000 mg/m³. Carbon dioxide is a colorless gas and does not have any odor warning qualities. Carbon dioxide (gas and as a component of gas mixtures) is a completely non-explosive and non-combustible substance. In the remaining part of the installation, carbon dioxide is present in the bound form in the solution as ammonium carbamate, ammonium carbonate or ammonium bicarbonate. After some time a human body can get used to low concentrations of CO₂ in the air (about 1.5%). Being inhaled for a long time, even at concentrations less than 5%, it gradually decreases the excitability of the respiratory center. Symptoms of CO₂ poisoning such as dyspnoea, disturbances of consciousness and convulsions may appear even after 30-minute gas inhalation. Inhaling toxic concentrations of 8-15% causes very quickly: pain, dizziness, chest tightness, somnolence, sometimes intoxication, vomiting and loss of consciousness. Heart rate and breathing are slowed, dyspnea and convulsions occur, followed by death. Inhalation of carbon dioxide at a concentration of 30 to 40% by volume causes immediate death due to respiratory paralysis.

1.2.3. Solutions of ammonium carbonate, urea and ammonium carbamate

Aqueous solutions of urea, ammonium carbonate, ammonium carbamate and ammonia are present in the urea production process. These solutions, with different content of particular components, have a temperature from 20°C to 200°C. Solution-induced burns are more difficult to treat compared to ordinary thermal burns, due to the additional effects of chemicals. It is advisable to wash the burned area with water and to apply a sterile dressing for first- and second-degree burns caused by contact with solution. The toxicological activity of the solution is like ammonia's, and the toxic effects are prevented in a similar way (clothing and insulating equipment).

1.2.4. Processing steam

The processing steam is present throughout the entire installation as a heating medium for the apparatus and piping system. It is supposed to prevent crystallization of the circulating solution, i.e. urea solution, ammonium carbamate solution. Burns occurs when a victim is in contact with heated components of the apparatus with steam or the steam condensate.

3. Hazard and operability study (HAZOP) - risk assessment

The risk of failure is a function of two variables - the prevalence (frequency) of a specific event and the extent (magnitude, effects) of a failure if it occurs. The value of risk is determined by the equation:

$$R=S \times C$$

where:

- R - risk level;
- C - prevalence (frequency);
- S - effects of a failure.

The matrix shown in Table 2 was used for further analysis of emergency events. The risk values calculated according to the above formula were inserted in Table 2. The risk was marked with the appropriate color in the risk matrix and categorized as follows: 1-3 - accepted risk - no additional safety and protection measures required (blue); 4-9 - acceptable tolerated risk - additional safety and protection measures should be considered if practically justified (green); 10-16 - unacceptable tolerated risk - additional safety and protection measures should be introduced (yellow); 20-25 - unacceptable risk - the installation has to be stopped and additional safety and protection measures have to be applied immediately (red) [3]. In addition, the risk analysis team has changed the category for two cases: a) for frequency - 4 and for effects - 1 (in order to increase risk reduction measures for situations where the likelihood of failure is at level 4) and b) for frequency - 1 and effects - 4 (to increase the risk reduction action for situations where the likelihood of failure is low, but the effects are at level 4).

Table 1 depicts the categories of effects that were adopted for the risk assessment.

Table 1. Effect categories

Effect category "S"	Employees	Population	Environment
Cat. 1 Negligible	minor injuries	none	none
Cat. 2 Minor	single medium injuries	odor, noise	minor, included in reports
Cat. 3 Average	medium and severe injuries	minor injuries	average damage
Cat. 4 Major	serious injuries	medium injuries	serious damage
Cat. 5 Catastrophic	fatalities	serious injuries	ecological disaster

Source: own elaboration

Table 2. Risk matrix

			Effects "S"				
			1	2	3	4	5
FREQUENCY „C“	5	very often	5	10	15	20	25

		Effects "S"				
		1	2	3	4	5
4	often	4	8	12	16	20
3	medium	3	6	9	12	15
2	rarely	2	4	6	8	10
1	very rarely	1	2	3	4	5

Source: own elaboration

A widely used HAZOP analysis method was chosen for hazard assessment [5]. A specialist team made up of technicians, operators, and automation technicians selected hazards for the analysis based on their prevalence and severity. The HAZOP analysis sheet was expanded by three columns to help assess the risk of failure for the threats analyzed (Table 3).

Table 3. Fragment of the HAZOP sheet for the node of the reactor

No	Watch word	Deviation	Reason	Effects	Safety measures	S	C	R
1.	Less	Less flow	Leakage at flange connection of the pipeline with the expansion valve (extruded gasket of ¼ of the circumference ϕ 80)	Outflow of liquid-gas reaction mixture to the environment	Technical inspection (current); concentration monitoring	3	3	9
2.	Less	Lower level / lower pressure	Mechanical damage of the nozzle on the inlet pipeline to the reactor	Outflow of the reaction mixture, including unreacted raw materials, from the reactor to the environment	Technical inspection (current); monitoring	5	2	10
3.	Less	Less flow	Weld damage on the pipeline of the circulation solution	Outflow of the circulating solution to the environment, emergency stop of the line	Technical inspection (current); monitoring	3	3	9
4.	Less	Less flow	Unsealing of the pipeline with ammonia due to corrosion	Outflow of ammonia to the environment, environment contamination, discharge into the atmosphere through the safety valve	Technical inspection (current); monitoring of ammonia concentration	3	3	9
5.	Less	Less flow	Unsealing of the heat exchanger tube with ammonia due to corrosion	Outflow of ammonia to the steam condensate, environment contamination	None	4	2	8
6.	More	Higher pressure	Failure and unsealing of safety valves on the ammonia pipeline	Discharge through the safety valve	Exhaust from the chimney	5	2	10
7.	More	Higher pressure	External fire	Pipeline rupture	Fire protection installation	5	2	10
8.	More	Higher pressure	External fire	Discharge into the atmosphere through the	Fire protection installation	4	2	8

No	Watch word	Deviation	Reason	Effects	Safety measures	S	C	R
9.	More	Higher pressure	Unsealing of the compressor	safety valve Discharge through the safety valve and gassing the compressor workstation	None	5	2	10
10.	No	Higher pressure of expanded mixture	No remote control of the control (expansion) valve; the valve remains in the open position;	Prevention of any change in the reactor load, inability to expand to adequate pressure and excessive pressure in successive apparatuses	The safety plate on the pipeline discharging the mixture from the reactor; the safety plate on another apparatus - expander I	5	2	10
11.	No	Increase in pressure and temperature in the reactor	No remote control of the expansion valve; the valve remains in the closed position;	Causing opening of safety valves on pipelines of circulating and ammonia solution causing environmental pollution.	Basic PBCS automation; opening of safety valves	4	2	8
12.	More	Increase of temperature of CO ₂ after 4 ^o of compression	Failure of the compressor or threat exchanger just behind the compressor, resulting in temperature rise	Change in color of solution; corrosion of the reactor lining;	Basic PBCS automation;	3	2	6
13.	More	Increase in temperature of NH ₃ after heating	Too strong flow of overheated steam through the heater, leading to the temperature rise	Increase in temperature in the reactor; color change of solution; decrease in the efficiency of the expansion;	Basic PBCS automation;	4	2	8
14.	Less	Less raw material of NH ₃ and CO ₂	Worsening of conversion	Improper flow of raw materials; reduced process efficiency	Basic PBCS automation;	2	2	4

Source: own elaboration

4. Contingency scenarios

On the basis of the HAZOP analysis (Table 3), four scenarios were selected for the analysis of further risk reduction measures.

3.1. The contingency scenario 1

During the operation of the urea synthesis installation under 100% load, the process operator observed after a few minutes that the control valve at the top of the synthesis reactor did not react to the control signal (pos. 11 in Table 3). The valve was blocked in an open position preventing the reactor from being loaded down and caused adverse effects on the next phase of production, due to the inadequate expansion of the mixture to less than 4 MPa. As a result, there was insufficient pressure reduction triggered by the safety plate operating (being torn) on another apparatus, i.e. the expander, and its damage. The upper body of the expander housing was weakened. The leakage of gas-liquid mixture prevented further process. The operator's in-

tervention and attempts at repairing the valve at the top of the reactor ended with second-degree burns resulting from unfavorable conditions (high pressure and temperature). It was necessary to shut off the reactor and the control valve (expansion valve) should be improved. Such a failure results in high economic losses due to the need for emergency stopping of the line, cooling the reactor to make the repair or replacement of the valve possible, repair of the expander housing and replacement of safety plates in the apparatus. Additional costs were generated by the need to re-start the reactor and the several-hour downtime on the line. By virtue of serious injuries and high costs, the impact was estimated at level 5, but the probability (frequency) of occurrence of this type of breakdown was estimated at level 2.

3.2. The contingency scenario 2

During the operation of the urea synthesis installation, after having it successfully started up and loaded down up to 100% performance, after a few minutes the process operator noticed that the control valve at the top of the synthesis reactor did not respond to the control signal (pos. 12 in Table 3). The valve was blocked in the closed position, preventing the reactor from being unloaded. If the compressor and pumps are not switched off in time, they cause the pressure to rise, which, in turn, leads to the opening of safety valves on the pipelines at the reactor entrance and leakage of the liquid-gas circulation mixture (i.e. hot solution of ammonia carbamate) as well as unreacted carbon dioxide and liquid ammonia. This breakdown resulted in serious injuries of two employees and high economic losses (including environmental). The leaking mixture is highly hazardous and toxic for operators handling it around the synthesis reactor, as well as other installations in the vicinity. The operator's intervention at the top of the reactor and the attempt to repair the valve is impossible due to high pressure and temperature. Human losses may result from unsealing that may occur during the maintenance of the installation and equipment by operators of the production line. Economic losses are due to the need for emergency stopping of the line and cooling of the reactor so as to enable repair or replacement of the valve. Additional costs are generated by the necessity of re-start of the reactor and several hours of line downtime. Furthermore, in such a case, the environment gets polluted with a toxic ammonia compound, which makes it necessary to neutralize the contaminant. Due to serious injuries and high costs, the impact was estimated at level 4, but the probability (frequency) of this type of breakdown was estimated at level 2.

3.3. The contingency scenario 3

During the operation of the urea synthesis installation, the inlet nozzle of the pipeline of the circulation solution was torn off and the mixture contained in the reactor leaked abruptly (pos. 2 in Table 3). The material defect and long service life of the apparatus were the reasons for the above. As a result of this failure, the reactor was completely emptied (approximately 80 m³) from the liquid-gas mixture. Economic losses are due to the need for emergency stopping and neutralization of contamination caused by the outflow of toxic ammonia and ammonium carbamate, repair of the reactor, line

breakdown and re-starting. Human losses are also a result of the accident - the scenario assumes serious injuries to the life of the operator. Due to serious injuries and high costs, the impact was estimated at level 5, but the probability (frequency) of this type of breakdown was estimated at level 2.

3.4. The contingency scenario 4

During the operation of the urea synthesis installation, the process operator observed a decrease in the temperature of the steam condensate in the ammonia preheater located in front of the synthesis reactor. The leakage of liquid ammonia from the ammonia preheater heated by superheated steam was caused by a tube break in the exchanger and ammonia leakage into the steam condensate (pos. 5 in Table 3). The temperature change was imperceptible and its value did not go beyond the permissible range. The flow of superheated steam through ammonia preheaters was fixed and suitable for the ammonia heating process, and only after a few minutes the ammonia concentration was exceeded several times over acceptable and detected by the operator. The synthesis node, including the ammonia heater, was excluded from operation. This failure causes high economic losses resulting from the need for emergency stopping of the line, cooling the reactor, emptying and cooling ammonia preheaters and repair or replacement of heat exchanger components. Costs will also be generated by re-start of the reactor and several hours of line downtime. In the case of unsealing and leakage of toxic substances, i.e. liquid ammonia, environmental damage resulting from the neutralization of toxic substances also appears. Human losses are possible due to the fact that unsealing can occur during handling the installation and devices by operators of a given production line. By virtue of serious injuries and high costs, the effects were estimated at level 4, but the probability (frequency) of this type of breakdown was estimated at level 2.

5. Safety function reducing the risk of outflow of urea solution from the reactor with pressure of above 4 MPa

There are numerous hazards that can cause breakdowns in process installations in chemical industry. The so-called safety functions are introduced in order to limit the risk of failure. The instrumented safety function is usually built from the input element (measuring device), logic system and operational element [6]. The degree of risk reduction is dependent on the structure and reliability of components. In their work Samociuk et al. presented an exemplary realization of the system reducing the risk of failure by using a parallel structure of pressure gauges [7].

The proposed safety function constitutes the required action for the hazard described in position 11 of the HAZOP analysis sheet (Table 3).

The outflow of the urea solution (ca. 34% by volume of the total mixture), ammonium carbamate as well as carbon dioxide and ammonia absorbed from the reactor at the pressure of over 4 MPa can be caused by the failure of the valve (1) (Figure 2). Due to the fact that breakdowns occurred in this type of installation, resulting in damage (fail-

ure) of the further part of the installation, despite appropriate safety measures, the use of the safety function consisting of the pressure sensor (2), the safety algorithm implemented as a lock in the DCS controller and the additional valve (3) was proposed. The control system is executed as follows:

- an operator controls the apparatus in manual mode;
- the algorithm in the DCS controller tracks the position (degree of opening) of the valve (1) and opens the valve adequately (3);
- when the ammonia pressure exceeds the set value (e.g. 3.9 MPa), the controller will automatically start shutting off the valve (3) to protect the remaining part of the system from damage;
- the operator has the possibility to deactivate the safety function in justified situations.

The application of this safety feature will reduce the frequency of this type of breakdown (from $C = 2$ to $C = 1$), which will lead to the change in the category from the unacceptable tolerated risk to the acceptable tolerated risk.

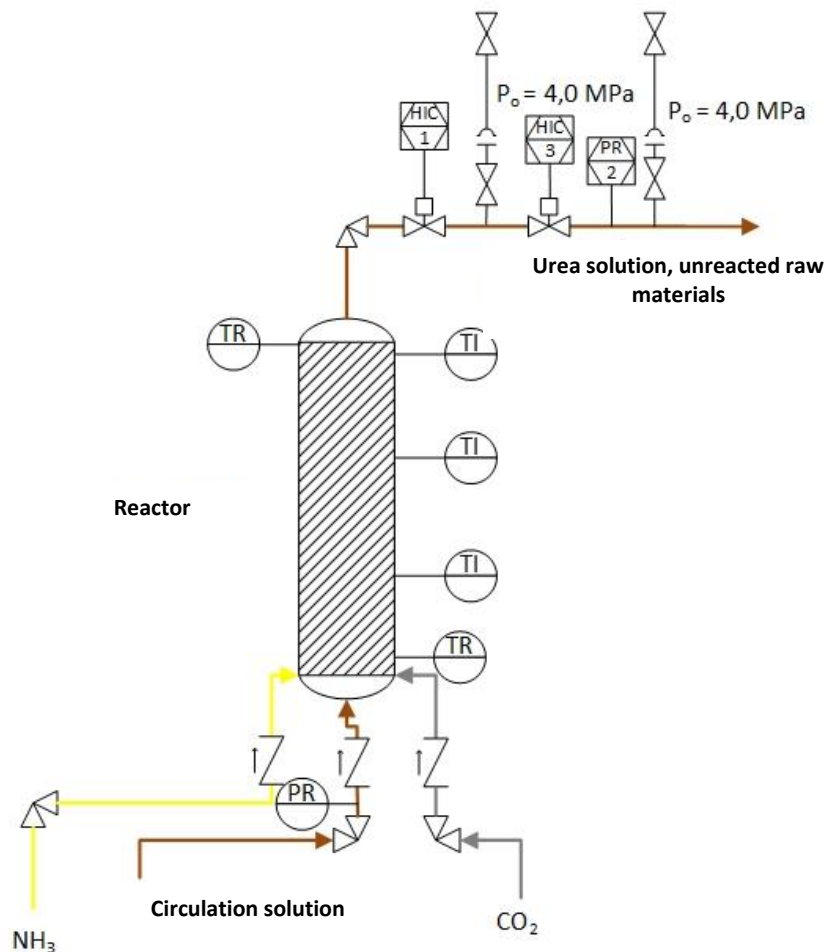

Fig. 2. Diagram of the proposed safety function
Source: own elaboration

Conclusions

1. The carried out HAZOP analysis, combined with the risk assessment has indicated the critical points of the installation for which appropriate preventive measures should be taken.
2. The proposed safety function allows for the reduction of the risk of an emergency event occurrence by using the parallel reliability structure of the expansion valves.
3. The algorithm minimizes the duration of unfavorable pressure values in the further part of the installation in an emergency event.
4. The safety function minimizes the effects of human error, consisting in too late operator's response to excessively elevated pressure behind the expansion valve.

Acknowledgement

No acknowledgement and potential founding was reported by the authors.

Conflict of interests

The author declared no conflict of interests.

Author contributions

All authors contributed to the interpretation of results and writing of the paper. All authors read and approved the final manuscript.

Ethical statement

The research complies with all national and international ethical requirements.

ORCID

The authors declared that they have no ORCID ID's

References

1. Kepinski J., *Technologia chemiczna nieorganiczna*, PWN, Warszawa 1984
2. Molenda J., *Technologia Chemiczna*, WSiP, Warszawa, 2006
3. Markowski A. S., *Zapobieganie stratom w przemyśle Czesc III - Zarzadzanie bezpieczenstwem przemyslowym*, Tempus, Wydawnictwo Politechniki Lodzkiej, Lodz 2000
4. Mikolajek D., *Charakterystyka specyficznych zagrozen z udzialem gazow trujacych, zracych (amoniak, chlor, dwutlenek siarki). Sposoby (systemy) przeciwdzialania za-*

grozoniom wewnatrz przedsiebiorstwa, Centrum ksztalcenia i doskonalenia kadr, Tarnow, 2007

5. PN-EN 61882, czerwiec 2005, Badania zagrozeni i zdolnosci do dzialania (badania HAZOP) – Przewodnik zastosowan.
6. Polska Norma PN-EN 61511-1 wrzesien 2007. Bezpieczenstwo funkcjonalne. Przyrzadowe systemy bezpieczenstwa do sektora przemyslu procesowego. Czesc 1: Schemat, definicje, wymagania dotyczace systemu, sprzetu i oprogramowania.
7. Samociuk W., Krzysiak Z., Szmigielski M., Zarajczyk J., Stropek Z., Golacki K., Bartnik G., Skic A., Nieoczym A., *Modernization of the control system to reduce a risk of severe accidents during non-pressurized ammonia storage* [in:] "Przemysl Chemiczny" 95/5(2016) p. 1032-1035
8. Najlepsze Dostepne Techniki (BAT) Wytyczne dla Branzy Chemicznej w Polsce; Przemysl Wielkotonazowych Chemikaliow Nieorganicznych, Amoniak, Kwasow i Nawozow Sztucznych Wersja II, [online]. [available: 15.06.2016]. Available on the Internet: [https://ippc.mos.gov.pl/ippc/custom/nawozy_II\(1\).pdf](https://ippc.mos.gov.pl/ippc/custom/nawozy_II(1).pdf)

Biographical notes

Aleksander Wyciszkievicz - Eng., graduated from Technical College No. 4 in Pulawy in 2011 with the chemical technology technician degree. He studied Chemical and Process Engineering at the Faculty of Production Engineering at the University of Life Sciences in Lublin. In 2017 he obtained the engineering degree. Currently he is a graduate student of Chemical Technology at the Faculty of Chemistry at the Silesian University of Technology in Gliwice.

Krzysztof Golacki - Prof. Dr. hab. Eng., graduated from the Faculty of Precision Mechanics (currently Mechatronics) at the Warsaw University of Technology. He was awarded the title of Professor in 2003. He is the Head of the Department of Mechanical Engineering and Automation of the Faculty of Production Engineering at the University of Life Sciences in Lublin. Specialization - agrophysics, automation of industrial processes. Since 2011 he has been the Program Director of the Safety Engineering.

Waldemar Samociuk - Dr. Eng., in 1993 he graduated from the Faculty of Mechanical Engineering at the Lublin University of Technology. He obtained a doctoral degree in technical sciences in 2006. In 2014 he completed postgraduate studies "Safety of Industrial Process" at the Faculty of Process Engineering and Environmental Protection at the Technical University of Lodz. He works as assistant professor in the Department of Mechanical Engineering and Automation of the Faculty of Production Engineering at the University of Life Sciences in Lublin. Specialization - control and modeling of industrial processes.

How to cite this paper

Wyciszkievicz A., Golacki K., Samociuk W., (2017) – Hazards and their reduction in urea production for synthesis reactor by mitsui - toatsu technology. *Scientific Journal of the*

Military University Of Land Forces, vol. 50, no. 1 (182), p. 150-164, <http://dx.doi.org/10.5604/01.3001.0011.7369>



This work is licensed under the Creative Commons Attribution International License (CC BY).
<http://creativecommons.org/licenses/by/4.0/>