

## **DYNAMIC CHARACTERISTICS MEASUREMENTS OF A FORCE TRANSDUCER AGAINST SMALL AND SHORT-DURATION IMPACT FORCES**

**Mitra Djamal<sup>1)</sup>, Kazuhide Watanabe<sup>2)</sup>, Kyohei Irisa<sup>2)</sup>, Irfa Aji Prayogi<sup>2)</sup>, Akihiro Takita<sup>2)</sup>, Takao Yamaguchi<sup>2)</sup> and Yusaku Fujii<sup>2)</sup>**

1) Faculty of Mathematics and Natural Sciences, Institut Teknologi Bandung, Jalan Ganesa 10, Bandung 40132, Indonesia (mitra@fi.itb.ac.id)

2) School of Science and Technology, Gunma University, 1-5-1, Tenjin-cho, Kiryu city, Gunma 376-8515, Japan (✉ fujii@el.gunma-u.ac.jp, +81-277-30-1756)

### **Abstract**

A method for evaluating the dynamic characteristics of force transducers against small and short-duration impact forces is developed. In this method, a small mass collides with a force transducer and the impact force is measured with high accuracy as the inertial force of the mass. A pneumatic linear bearing is used to achieve linear motion with sufficiently small friction acting on the mass, which is the moving part of the bearing. Small and short-duration impact forces with a maximum impact force of approximately 5 N and minimum half-value width of approximately 1 ms are applied to a force transducer and the impulse responses are evaluated.

Keywords: dynamic force, impulse response, force transducer, force sensor, inertial force, optical interferometer.

© 2014 Polish Academy of Sciences. All rights reserved

### **1. Introduction**

Recently, the requirements for measuring dynamic forces have become more stringent in many industrial and research applications such as process monitoring, materials testing, model analysis and crash testing. For example, almost all the commercial mechanical material testers, such as tensile testers, compression testers, fatigue testers and viscoelasticity testers, use force transducers to measure the varying force acting on the materials under test. Many production machines, such as press machines and rolling mills, use force transducers to monitor the varying force acting on the materials under processing. However, at present, only static methods—i.e., techniques where transducers are calibrated using the gravitational force acting on the standard mass under static conditions—are widely available. Methods for the dynamic calibration of force transducers are important to meeting the above requirements.

Although methods for the dynamic calibration of force transducers are not yet well established, some methods of analyzing the electric and mechanical response of force transducers against impact forces have been proposed [1, 2]. In these methods, the inertial mass of the part of the transducer itself is considered to be the cause of the difference between the static response and the dynamic response of the transducer. However, no impact force traceable to the International System of units (SI units) is used as the reference force in these methods. Therefore these methods cannot be considered to be dynamic calibration methods for force transducers. Another method, in which the oscillation force generated using the shaker and the inertial mass is used as the reference force, has been proposed [3]. This method will be effective for the oscillation force calibration for force transducers.

On the other hand, a method, the Levitation Mass Method (LMM), has been proposed by the authors [4–6]. The levitation mass method was first proposed [3] to evaluate the impulse

response for force transducers: a mass collides with a force transducer, and the impulse (i.e., time integration of the impact force) is measured with high accuracy as a change in the momentum of the mass. To achieve linear motion with sufficiently small friction acting on the mass, a pneumatic linear bearing [7] is used, and the velocity of the mass (i.e. moving part of the bearing) is measured using an optical interferometer. At present, the impulse response of force transducers with a minimum capacity of 200 N has been evaluated for impulses with a half-value width of greater than 5 ms. However, a method for evaluating the response to smaller impact forces with shorter durations is sometimes required for practical applications in industry and science.

In this study, small and short-duration impact forces with a maximum impact force of approximately 5 N and minimum half-value width of approximately 1 ms were applied to a force transducer, and the impulse responses were evaluated. To achieve a smaller force, a small pneumatic linear bearing [8] was used. To improve the sampling interval, a novel frequency estimation method based on the digitized waveform [9] was introduced.

## 2. Experimental setup

Fig. 1 shows a schematic diagram of the experimental setup for evaluating the dynamic characteristics of force transducers subjected to small and short-duration impact forces. A linear air bearing was used to achieve linear motion with sufficiently small friction acting on the mass (i.e., moving part of the bearing). An impact force was generated and applied to the force transducer being tested by collision with the mass. The force transducer (CLS-5NA, Tokyo Sokki Kenkyujo Co. Ltd.) had a detection sensitivity of up to 5 N and was calibrated under the static condition with a standard uncertainty of 0.02 N. The output signal of the force transducer was recorded using a strain recorder (DC-204R, Tokyo Sokki Kenkyujo Co. Ltd.) with a sampling capacity of 65,536 samples and a sampling rate of 100,000 samples per second. Fig. 2 shows the photo around the test section.

A cube-corner prism (CC) to interact with the interferometer and a metal block with a rubber damper to adjust to the collision position were attached to the moving part. Two dampers were prepared: Damper-A (metal part with silicon-rubber tip) and Damper-B (metal part with fluorine-rubber tip). The total mass  $M$  of the moving part with Damper-A or Damper-B was approximately 19.278 or 17.878 g, respectively. The inertial force acting on the mass was accurately measured using an optical interferometer. A Zeeman-type two-frequency He–Ne laser was used as the light source.

The force acting on the transducer from the moving mass was measured as the inertial force of the moving part—i.e.,  $F_{\text{mass}} = M a$ . Acceleration  $a$  was derived from the velocity of the moving mass. The velocity was derived from the measured value of the Doppler shift frequency of the signal beam of the laser interferometer  $f_{\text{Doppler}}$ , which can be expressed as

$$v = \lambda_{\text{air}} (f_{\text{Doppler}}) / 2, \quad (1)$$

$$f_{\text{Doppler}} = -(f_{\text{beat}} - f_{\text{rest}}), \quad (2)$$

where  $\lambda_{\text{air}}$  is the wavelength of the signal beam under the experimental conditions,  $f_{\text{beat}}$  is the beat frequency (i.e., frequency difference between the signal beam and reference beam), and  $f_{\text{rest}}$  is the rest frequency, which is equivalent to  $f_{\text{beat}}$  when the moving part is stationary. Only the motion-induced time-varying beat frequency was measured in the experiment; all other quantities such as the velocity, position, acceleration, and force were calculated numerically afterwards.

A digitizer (NI PCI-5105, National Instruments Corp., USA) recorded signals from PD1 and PD2 (5M samples for each channel) at a sampling rate of 30M samples per second at 8-bit resolution. The measurement duration of the digitizer was 0.17 s.

Frequencies  $f_{beat}$  and  $f_{rest}$  were accurately determined from the digitized waveforms of PD1 and PD2, respectively, using the recently developed Zero-Crossing Fitting method (ZFM). In ZFM, all zero-crossing times are used to determine the frequency of each gate time, which is defined by 200 periods of the signal waveform [7].

The measurements using the digitizer (NI PCI-5105) and recorder were initiated by a sharp trigger signal generated using a digital-to-analog converter (DAC). This signal was activated by a light switch, which was a combination of a laser diode and a photodiode.

In the experiment, 25 collision measurements were taken for each damper.

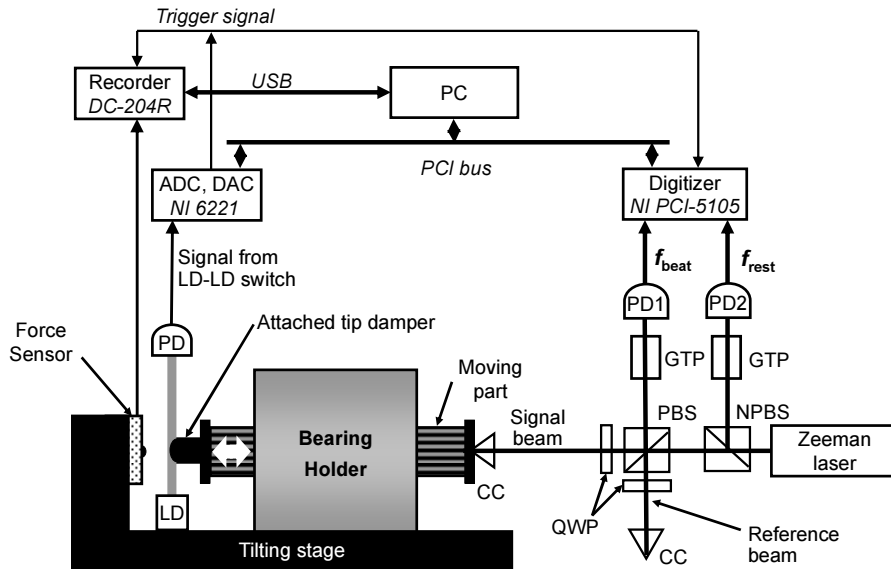

Fig. 1. Experimental setup. Code: CC = cube corner prism, PBS = polarizing beam splitter, NPBS = non-polarizing beam splitter, GTP = Glan-Thompson prism, QWP = quarter wave plate, PD = photodiode, LD = laser diode, PC = computer.

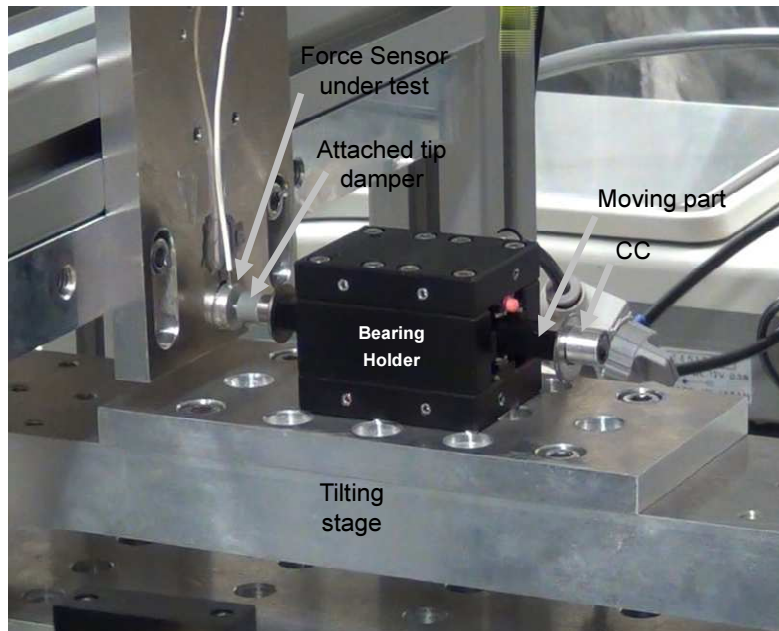

Fig. 2. Photo around the test section.

### 3. Results

Fig. 3 shows the data processing procedure, in which velocity, acceleration and force are calculated from the measured frequencies,  $f_{beat}$  and  $f_{rest}$ . Fig. 4 shows the force acting on the mass  $F_{mass}$ , the force calculated based on the output signal of the force transducer and its static calibration results  $F_{trans}$ , and their difference  $F_{diff}$  ( $= F_{trans} - F_{mass}$ ) in a collision experiment with Damper-A. In order to calculate  $F_{diff}$ , the timing of  $F_{mass}$  was adjusted to that of  $F_{trans}$  using linear interpolation. The maximum value  $F_{mass, max}$  and the full width at half maximum  $W_{FWHM}$  of the impact force  $F_{mass}$  were approximately 4.76 N and 2.0 ms, respectively. The root mean square (RMS) values of the force difference  $F_{trans} - F_{mass}$  during the collision period were approximately 0.058 N.

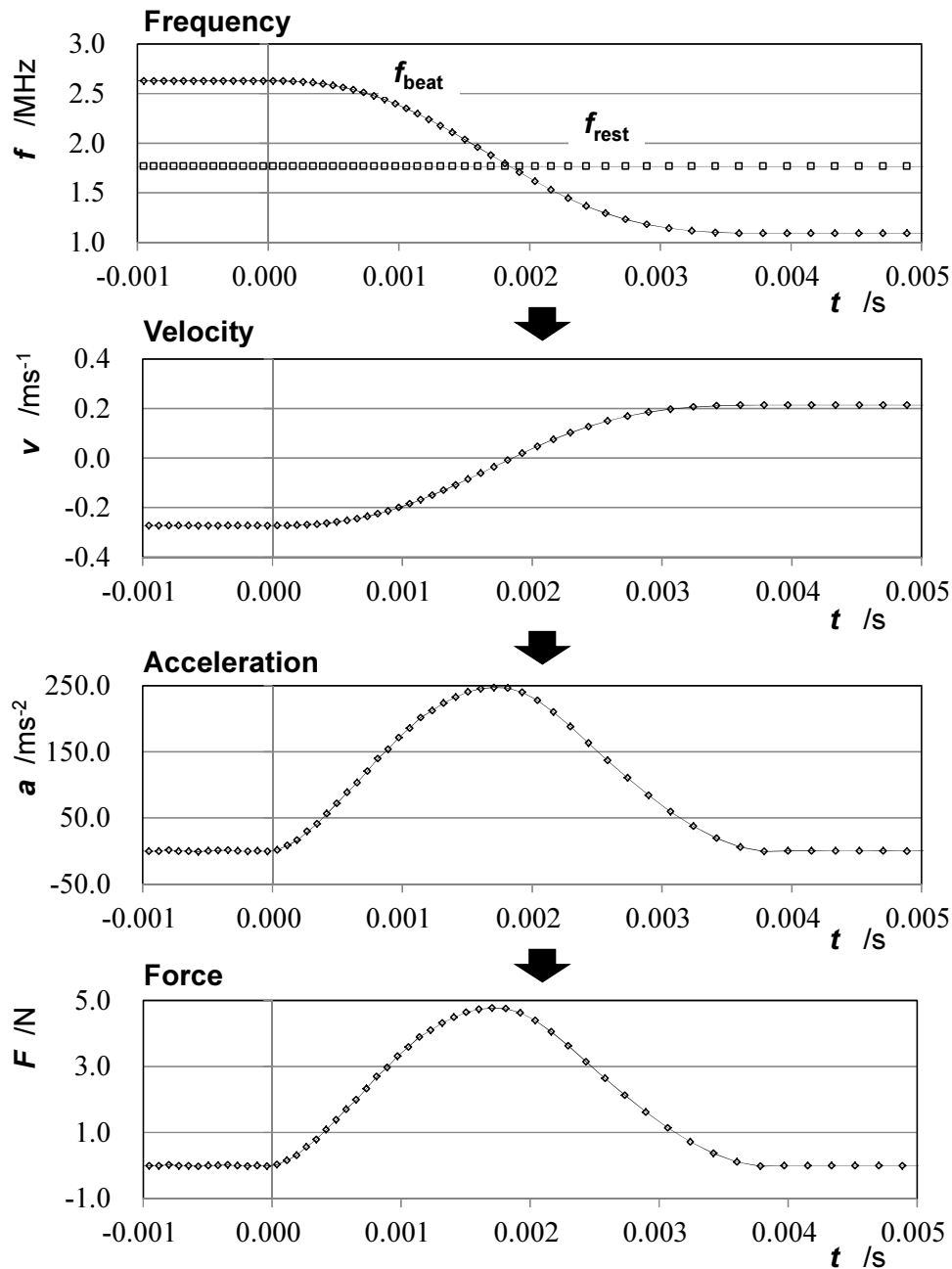

Fig. 3. Data processing procedure: Calculation of velocity, acceleration and force from measured frequency.

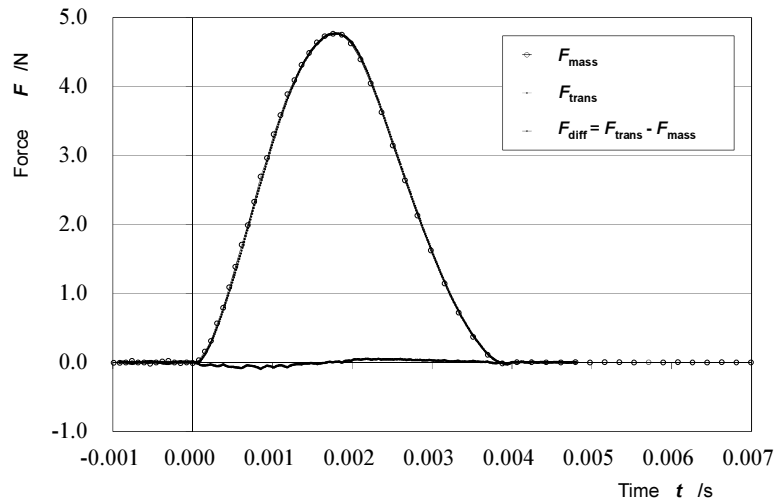

Fig. 4. Force calculated from output signal of the force transducer and its static calibration results  $F_{trans}$ , force acting on the mass  $F_{mass} (= Ma)$ , and their difference  $F_{diff} = F_{trans} - F_{mass}$ . Damper-A was used.

Fig. 5 shows the relationship between the full width at half maximum  $W_{FWHM}$  of the impact force and the maximum impact force  $F_{mass, max}$  for the 50 collision measurements with Damper-A and Damper-B. The full width at half maximum  $W_{FWHM}$  were in the range of 1–3 ms. The maximum impact forces  $F_{mass, max}$  were in the range of 0–5 N.

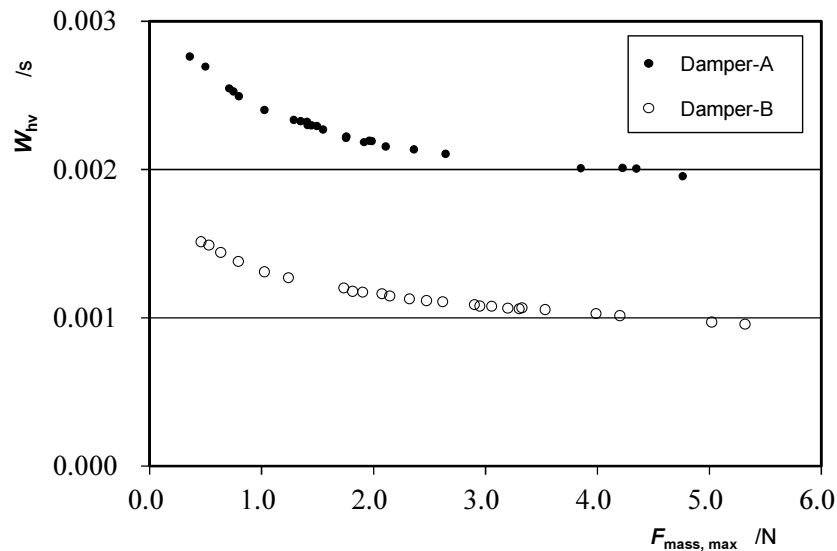

Fig. 5. The full width at half maximum  $W_{FWHM}$  against the maximum impact force  $F_{mass, max}$  as measured with Damper-A and Damper-B.

Fig. 6 shows the RMS values of the errors  $F_{diff} (= F_{trans} - F_{mass})$  for Damper-A and Damper-B. Regression lines are also shown in the figure. The solid and dashed lines show  $RMS(F_{diff}) = 0.0081 F_{mass, max} + 0.0022$  and  $RMS(F_{diff}) = 0.0105 F_{mass, max} + 0.0020$ , respectively. Only data pertaining to the pulses were analyzed. The RMS values of the differences between the measured values and the regression lines, i.e. the solid and dashed lines, are 0.003 N and 0.006 N, respectively.

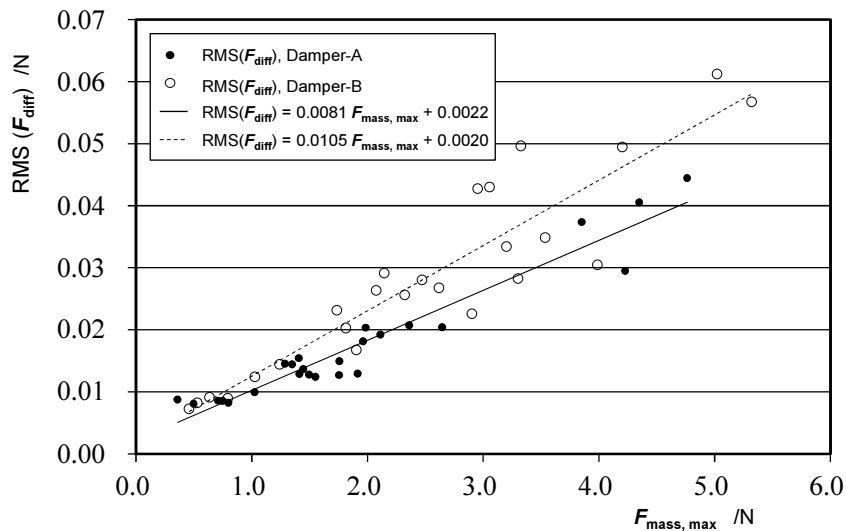

Fig. 6. Root mean square (RMS) values of the errors of the force  $F_{\text{diff}} = F_{\text{trans}} - F_{\text{mass}}$  measured with Damper-A and Damper-B.

#### 4. Evaluation of uncertainty

The uncertainty sources when determining the instantaneous value of the force  $F_{\text{mass}}$  acting on the force transducer being tested are as follows:

[A] Uncertainty same as that during the free sliding motion before and after collision

The uncertainty sources in measuring the force are as follows:

- [A.1] Noise of the optical interferometer
- [A.2] Frequency estimation using the ZFM
- [A.3] Calculation of  $F_{\text{mass}}$  from the frequency
- [A.4] Dynamic frictional force acting inside the bearing

The frictional force acting inside the bearing was estimated to be 0.6 mN at the maximum velocity used in the experiments (0.3 m/s). Thus, this force is negligible.

Although [A.1], [A.2], and [A.3] are difficult to estimate separately, the uncertainty caused by them is thought to be similar between inside the impulse and outside the impulse. The RMS value of  $F_{\text{mass}}$  outside the impulse, i.e. during the free sliding motion before and after the collision, was approximately 7 mN for the 50 measurements. Therefore, the combined uncertainty of [A.1], [A.2], [A.3], and [A.4] was estimated to be 7 mN.

[B] Uncertainty differing from that during the free sliding motion before and after the collision

The uncertainty sources estimated to be zero when the force was zero are as follows:

- [B.1] Optical alignment

The major source of uncertainty in the optical alignment was the inclination of the 1 mrad signal beam; this resulted in a relative uncertainty in the inertial force of approximately  $5 \times 10^{-7}$ , which is negligible.

- [B.2] Mass calibration

The uncertainty in the mass measurement when using the electric balance was approximately 0.01 g, which corresponds to 0.05% of the total mass of the moving part. This corresponds to 3 mN when  $F_{\text{mass}} = 5 \text{ N}$ .

Therefore, the standard uncertainty when determining the instantaneous value of the force  $F_{\text{mass}}$  acting on the force transducer being tested was estimated to be 8 mN, which corresponds to 0.16% of the maximum force applied in the experiments (5 N).

## 5. Discussion

This paper proposes a method for evaluating the dynamic characteristics of force transducers subjected to small and short-duration impact forces. This method can significantly contribute to realizing dynamic force measurements in the fields of science and technology.

Small and short-duration impact forces with a maximum impact force of approximately 5 N and minimum half-value width of approximately 1 ms were applied to the force transducer, and the impulse responses were evaluated. The evaluated dynamic error of the transducers, shown in Fig. 4, was greater than the uncertainty in the static calibration (0.02 N).

Future research will involve determining the cause of this error and correcting it by evaluating various kinds of transducers with wider ranges for the width and peak value of the impact forces.

## 6. Conclusions

A method for evaluating the dynamic characteristics of force transducers subjected to small and short-duration impact forces was developed. In this method, a small mass collides with a force transducer, and the impact force is measured with high accuracy as the inertial force of the mass. A pneumatic linear bearing was used to realize linear motion with sufficiently small friction acting on the mass (i.e., moving part of the bearing). Small and short-duration impact forces with a maximum impact force of approximately 5 N and minimum half-value width of approximately 1 ms were applied to a force transducer, and the impulse responses were evaluated. Using this method, the dynamic characteristics of force transducers, which are used in the material testers and the production machines to measure small and short-duration impact forces, can be evaluated.

## Acknowledgements

This work was supported in part by the research-aid fund of the International Research Collaboration and Scientific Publication of Directorate General of Higher Education (DGHE) of Rep. of Indonesia (contract Nr. 1216.a/I.1.C01/PL/2013), a research-aid fund from the Asahi Glass Foundation, a research-aid fund of the NSK Foundation for the Advancement of Mechatronics (NSK-FAM), and the Grant-in-Aid for Scientific Research (B) 24360156 (KAKENHI 24360156).

## References

- [1] Li, Y.F., Chen, X.B. (1998). On the dynamic behavior of a force/torque sensor for robots. *IEEE Trans. Instrum. Meas.*, 47, 304–308.
- [2] Xu, K.J., Jia, L. (2002). One-stage identification algorithm and two-step compensation method of Hammerstein model with application to wrist force sensor. *Rev. Sci. Instrum.* 73, 1949–1955.
- [3] Park, Y.K., Kumme, R., Kang, D.I. (2002). Dynamic investigation of a binocular six-component force-moment sensor. *Meas. Sci. Technol.*, 13, 1311.
- [4] Fujii, Y., Fujimoto, H. (1999) Proposal for an impulse response evaluation method for force transducers. *Meas. Sci. Technol.*, 10, N31–33.
- [5] Fujii, Y. (2009) Toward establishing dynamic calibration method for force transducers. *IEEE Trans. Instrum. Meas.*, 58, 2358–2364.

- [6] Fujii, Y., Maru, K. (2011) Self-correction method for dynamic measurement error of force sensors. *Experimental Techniques.*, 35(3), 15–20.
- [7] Fujii, Y. (2006) Frictional characteristics of an aerostatic linear bearing. *Tribol. Int.*, 39, 888–896.
- [8] Fujii, Y. (2007) [Microforce materials tester based on the levitation mass method.](#) *Meas. Sci. Technol.*, 18, 1678–1682.
- [9] Fujii, Y., Hessling, J.P. (2009) Frequency estimation method from digitized waveform. *Experimental Techniques*, 33, 64–69.