

Received August 20, 2020; reviewed; accepted November 03, 2020

Dynamic analysis of a dashpots equipped vibrating screen using finite element method

Hamid Khoshdast ¹, Hami Khoshdast ², Saeid Jalilifard ³

¹ Department of Mining Engineering, Higher Education Complex of Zarand, Zarand, Iran

² Modeling and Simulation Division, FOCUS® Minerals Engineering Research Center, Stuttgart, Germany

³ Department of Mechanical Engineering, Higher Education Complex of Firoozabad, Firoozabad, Iran

Corresponding author: khoshdast_hamid@yahoo.com (Hamid Khoshdast)

Abstract: Even though vibrating screens have been used in mining industries for over a century, their use has often been cited as challenging in terms of understanding its dynamic responses to different operating factors, particularly those that affect the structural aspects. Among the various aspects of screen design, the control of vibrational energies imposed on various parts of the screen is of particular importance because these vibrations directly affect the separation efficiency and useful life of the screen. This study proposes the use of vibration absorbers to control the adverse effects of severe screen vibrations. The dynamic behavior of a medium-sized vibrating screen utilized in the aggregate industry was investigated using the finite element method for both spring/dashpots and conventional solely spring systems. The modeling process was performed in loaded and unloaded conditions and in three frequencies of 15, 23, and 27 rad/s. Numerical simulation results showed that the use of dashpots can significantly reduce the maximum stress in the screen, such that the maximum stress in the center of gravity of the screen at the optimal frequency of 23 decreased from 237 to about 97 MPa. Also, sieve modal analysis showed that the stress in the sieve equipped with the spring/dashpots system had a more uniform distribution. The results revealed that the use of vibration absorbers can be a promising solution to prevent damage caused by high vibrational energies in screens.

Keywords: vibrating screen, dashpots, dynamic characteristic, numerical simulation, FEM modeling

1. Introduction

The screening of solid particles by vibrating screens is an industrial practice commonly adopted in the mining sector. In mineral processing applications, screening is the basic process employed in a wide range of stages, such as:

- Prevention of particles smaller than the crusher outlet from entering the crushing chamber; this will increase their capacity and efficiency.
- Prevention of large particles from entering the next stage in the closed circuit of the comminution operation
- Preparation of the final product with a certain size (such as aggregate industry)
- Desliming and dewatering in the coal beneficiation industry

Among different kinds of static and moving classification machines, vibrating screens are the most frequently applied devices to sieve and sort a mineral particulate feed with a wide size distribution into two or more closely-sized products depending on the process requirements (Kelly and Spottiswood, 1982; Wills and Napier-Munn, 2007; Peng et al., 2018).

Although such devices have been widely incorporated in the production sector, in-depth analyses of the dynamic behavior and the process effectiveness of vibrating screens are foreign to the research work connected with the design and optimization of these machines. Due to the way vibrating screens work, as well as their intermittent movement and fatigue cycle, one of the main problems in screens is

the failure of various components. The need to reduce the occurrence of structural fractures for vibrating screens under different loading conditions necessitates dynamic analysis and related interpretations in this area. Too much driving force imposed on the screen body may increase the potential fatigue in the vibrating screens. Engineering experience has shown that even static forces under certain conditions can damage the screen. Therefore, the performance, structure, and strength of the vibrating screens must be regarded dynamically in the process of screen design and optimization (Parlar, 2010; Baragetti and Villa, 2014).

Dynamic simulation of vibrating screens has been conducted by numerous investigators. The relevant kinematic and dynamic problems are generally solved using numerical methods. For example, Solding (1999, 2002) described the dynamics of the particulate onto the screen by elaborating an analytical model to estimate the transport velocity of rock material over a vibrating screen of assigned circular motion. Zhao et al. (2009) conducted a dynamic analysis to evaluate the structural response of a mining vibrating screen and, then, used the results to optimize the shape of the screen. Some researchers have performed a dynamic simulation of vibrating screens to describe the particulate motions over vibrating sieves and to assess the effect of some operating parameters for the optimization of the screen's efficiency, such as the screen-deck inclination angle and the maximum vibration amplitude (Wang and Tong, 2011; Zhao et al., 2011).

The results of dynamic simulations have led to the successful development of new vibrating screens with lower noise (Zhu et al., 2004) and vibration (Gao, 2012). Yantek and Lowe (2011), using dynamic optimization, developed a vibrating screen with an added mechanism suspension for lower noise levels. Ramatsetse et al. (2013) provided detailed methodologies to be used for concept selection, structural analysis, component simulation, and performance evaluation of the vibrating screens. Their method also provides suitable guidance for designers to make appropriate decisions from the initial design stage to the commercialization of the designs. Baragetti and Villa (2014) introduced an innovative design strategy for the optimization of the dynamic performances and the structural loads of heavy loaded vibrating screens. They used their methodology to find the parameters apt to minimize the pitching angle of a vibrating screen in an asphalt plant. Dynamic simulation has also been accepted as a useful diagnostic tool for potential damages to different parts of vibrating screens. For example, Ding et al. (2012) performed modal analysis and harmonic response analysis to obtain the dynamic data of a vibrating screen, such as the natural frequencies, mode shapes, stress distribution, and strain distribution. They showed that the stiffness of the screen frame is higher than that of the screen, and the side plats and beams of the screen are the weak parts. Some other investigators have conducted dynamic studies as a qualitative fault diagnosis of the damping springs of vibrating screens (Peng et al., 2014; Peng and Liu, 2015; Ramatsetse et al., 2017, 2019). The effect of operating parameters, including load amplitude (Michalczyk and Cieplak, 2016; Jiang et al., 2017), feeding conditions (Michalczyk et al., 2017), screen structure (Zhang et al., 2017; Zhou et al., 2019), and vibration characteristics (Xiong et al., 2017) on the sorting performance of vibrating screens have also been examined. Recently, Peng et al. (2018) studied a more accurate dynamic model for dual-side excitation large vibrating screens. They proposed an elastic compression bar model method for transverse stiffness determination of a metal cylindrical coiled spring and provided guidance for the design of high-performance large vibrating screens.

Despite numerous studies on the dynamic simulation of vibrating screens, few of their results have been used on an industrial scale to modify large-scale screens. So far, these analyses have been applied to obtain the vibrational modes and weak points of the body and side planes of industrial screens from the point of view of fatigue and failure, and have been used by manufacturers to improve the quality of longer-lasting industrial screens (Zhang, 2016; Ramatsetse et al., 2017; Peng et al., 2019). Although one of the key components affecting the vibrational behavior of the screen is the springs system, very few studies have examined the behavior and optimization of this part of the screens (Vergnano et al., 2017). Currently, some manufacturers use rubber rings instead of the springs system which, despite the initial improvement in vibrational behavior and reduced screening noise, crack quickly and shorten the replacement time due to poor shock resistance caused by feeding fluctuations and extreme weather changes (especially in very warm and dry areas).

Therefore, to enjoy the benefits of rubber rings, including noise reduction and improvement of the vibration behavior of screens, and due to the longer life of the springs system, in this study, the idea of coupling the two systems using the spring/dashpots system was investigated. Therefore, we employed the finite element method (FEM) to evaluate the potential application of the spring/dashpots system instead of the conventional solely spring system for optimizing the dynamic characteristics of a vibrating screen. In addition, a simple modal analysis was also conducted to visually investigate the results of the FEM optimization of the screen. To the best of the authors' knowledge, this is the first study on the application of dashpots in vibrating screens.

2. Theoretical background

The motion of the screen body in a steady state can be decomposed into several displacement components, and each displacement component can be expressed by the Cartesian coordinate and is called the degree of freedom (DOF). The kinetic characteristics of the screen body are usually obtained by solving the dynamic equation established based on the dynamic model, which is often created according to the vibration theory (Rodriguez et al., 2016; Jiang et al., 2017; Wang et al., 2017). As a kind of vibration machine, the dynamic model of a vibrating screen is similar to the other vibration machines and they all belong to a mass-damping-stiffness system in the vibration theory. From the viewpoint of engineering applicability, the models with two degrees of freedom are one of the simplest and most commonly implemented models in the actual vibrating screen design. Such models are suitable for vibrating screens with line-trajectory where the screen body undergoes simple harmonic motions and the law of motion of each position on the screen is the same (Chandravanshi and Mukhopadhyay, 2017a, b; Peng et al., 2019).

Fig. 1 shows the layout of the vibrating screen and geometrical description of the supports and active force location with respect to the system center of gravity (CG). Simply speaking, the vibrating sieve system can be modeled as a rod with mass m and moment of inertia J_0 , located on two springs with stiffness K_1 and K_2 . The status of this system can be specified at any time by the coordinates $X(t)$ and $\theta(t)$, or by the coordinates $X_1(t)$ and $X_2(t)$. According to the model displayed in Fig. 1, this system has two possible transient movements along the y-axis and rotational directions; therefore, it has two DOF. Systems that require two independent coordinates to describe their motion are called systems with two DOF. Such systems have two equations of motion. Each equation is for a mass or, more precisely, for a DOF. In general, these equations are paired as differential equations, i.e. they contain both coordinates and assuming a harmonic solution for each coordinate, the frequency equation is obtained. This equation gives two natural frequencies. The free vibrations of a system with these frequencies are called natural oscillations. Therefore, the system with two DOF has two natural modes, each of which corresponding to one of the natural frequencies. The free vibrations of a system are a combination of two natural modes. If the system oscillates due to an external harmonic force, the frequency of the induced harmonic vibrations is the same as the frequency of the applied force. In this case, if the excitation frequency is equal to one of the normal frequencies of the system, amplification occurs (amplitudes reach the maximum value). The free vibration equations of the system include the equations of motion and momentum. The equation of motion using the coordinates $X(t)$ and $\theta(t)$ for the free diagram in Fig. 1 in the vertical direction is as follows (Slepyan and Slepyan, 2014; Jiang et al., 2017; Michalczyk et al., 2017):

$$k_2(l_2\theta(t) + X(t)) + k_1(X(t) - l_1\theta(t)) + mX''(t) = 0 \quad (1)$$

where l_1 and l_2 are the distances from the CG to the ends of the screen along the x-axis, and X'' is the acceleration of the centroid along the x-axis. The momentum equation with respect to CG is:

$$J_0\theta''(t) + k_2l_2(l_2\theta(t) + X(t)) - k_1l_1(X(t) - l_1\theta(t)) = 0 \quad (2)$$

where θ'' is the angular acceleration of the centroid. To solve the above equations, one has:

$$X(t) = X_0e^{it\omega} \quad (3)$$

$$\theta(t) = \theta_0e^{it\omega} \quad (4)$$

where X_0 is the amplitude of the centroid displacement along the x-axis, θ_0 is the amplitude of the centroid angular displacement, and ω is the motor speed. From Equations (1) to (4), it is concluded that:

$$(\theta_0 k_1 l_1 - \theta_0 k_2 l_2 - k_1 X_0 - k_2 X_0 + m X_0 \omega^2) e^{it\omega} = 0 \tag{5}$$

$$(\theta_0 J_0 \omega^2 - \theta_0 k_1 l_1^2 - \theta_0 k_2 l_2^2 + k_1 l_1 X_0 - k_2 l_2 X_0) e^{it\omega} = 0 \tag{6}$$

$$\theta_0 k_1 l_1 - \theta_0 k_2 l_2 - k_1 X_0 - k_2 X_0 + m X_0 \omega^2 = 0 \tag{7}$$

$$\theta_0 (J_0) \omega^2 - \theta_0 k_1 l_1^2 - \theta_0 k_2 l_2^2 + \theta_0 k_2 l_2^2 + k_1 l_1 X_0 - k_2 l_2 X_0 = 0 \tag{8}$$

It is observed that Eq. (8) has a trivial solution of $X_1=X_2=0$ (i.e. The system does not have an oscillating motion). To solve the non-trivial, the determinants of coefficients X_1 and X_2 must be equal to zero:

$$\det \begin{pmatrix} -m\omega^2 + k_1 + k_2 & k_2 l_2 - k_1 l_1 \\ k_2 l_2 - k_1 l_1 & k_1 l_1^2 + k_2 l_2^2 - \omega^2 J_0 \end{pmatrix} = 0 \tag{9}$$

As a result:

$$-J_0 k_1 \omega^2 - J_0 k_2 \omega^2 + J_0 m \omega^4 - k_1 l_1^2 m \omega^2 - k_2 l_2^2 m \omega^2 + k_1 k_2 l_1^2 + k_1 k_2 l_2^2 + 2k_1 k_2 l_1 l_2 = 0 \tag{10}$$

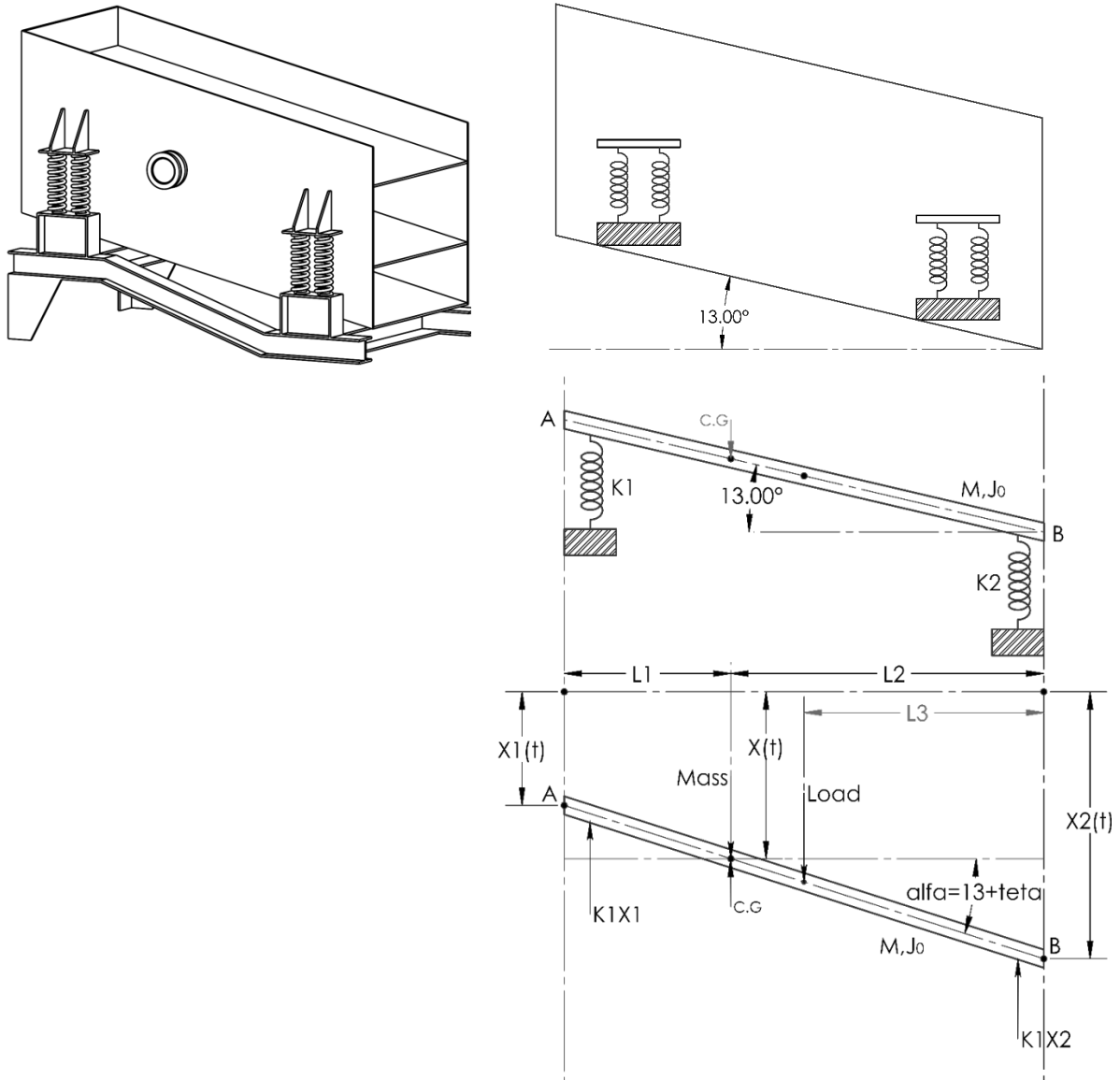

Fig. 1. Simplified model showing the loads and reactions on the studied vibrating screen

Eq. (10) is called the frequency equation or the characteristic equation. Upon solving this equation, natural frequencies are obtained as below:

$$\omega_1 = \pm \frac{\sqrt{(-J_0 k_1 - J_0 k_2 + k_1 l_1^2 (-m) - k_2 l_2^2 m)^2 - 4 J_0 m (k_1 k_2 l_1^2 + 2 k_1 k_2 l_1 l_2 + k_1 k_2 l_2^2) + k_1 l_1^2 + k_2 l_2^2 + \frac{k_1}{J_0} + \frac{k_2}{J_0} + \frac{m}{m}}}{J_0 m \sqrt{2}} \tag{11}$$

$$\omega_2 = \pm \sqrt{\frac{\sqrt{(-J_0k_1 - J_0k_2 + k_1l_1^2(-m) - k_2l_2^2m)^2 - 4J_0m(k_1k_2l_1^2 + 2k_1k_2l_2l_1 + k_1k_2l_2^2)} + k_1l_1^2 + k_2l_2^2 + \frac{k_1}{m} + \frac{k_2}{m}}{J_0m}} \quad (12)$$

By solving the system of Eqs. (5) to (8) and for the obtained natural frequencies, the natural modes of the system are obtained as follows:

$$\vec{X}^{(1)} = \begin{pmatrix} X_0 \\ \{-0.00029338X_0\} \end{pmatrix} \quad (13)$$

$$\vec{X}^{(2)} = \begin{pmatrix} X_0 \\ \{0.00698679X_0\} \end{pmatrix} \quad (14)$$

The equation of the system in the case of induced vibrations will also be as follows:

$$k_2(l_2\theta(t) + X(t)) + k_1(X(t) - l_1(\theta(t)) + mX''(t) - F_1 \cos(\omega t) = 0 \quad (15)$$

$$J_0\theta''(t) + k_2l_2(l_2\theta(t) + X(t)) - k_1l_1(X(t) - l_1\theta(t)) = 0 \quad (16)$$

3. Simulation methodology

A dashpot is a mechanical component or device which resists motion depending on its elasticity characteristics. There are various types of dashpots which are mainly used in the automobile industry as a damper against slamming shuts. Dashpots are also used as models of materials that exhibit a viscoelastic behavior, such as muscle tissue. Thus, the damping action of dashpots was considered as the concept of the present study. Fig. 2 illustrates the structure of the proposed spring and spring/dashpots systems. To evaluate the feasibility of using the spring/dashpots system, the dynamic and vibrational behavior of a small 2 m² vibrating screen was simulated in two modes of the solely spring system and the spring/dashpots system. The FEM was picked as the simulation approach as it is the most widely used numerical method for solving engineering problems such as the traditional fields of structural and stress analysis, heat transfer, and mass transport.

In general, the simulation process in this study followed the steps depicted in Fig. 3, which are discussed in detail in the following sections. According to the figure, the first step for simulating the screens is to design the various components of the screen in three dimensions. However, parts of the model are usually simplified to accelerate the simulation process and reduce errors. Then, the physical and mechanical properties of various components are defined as fixed parameters of the model. To solve a problem, the FEM subdivides a large system into smaller, simpler parts called finite elements. This is achieved by a particular space discretization in the space dimensions, which is implemented by the construction of a mesh of the object: the numerical domain for the solution, which has a finite number of points. At this stage, the selection of the type and number of meshes has a significant effect

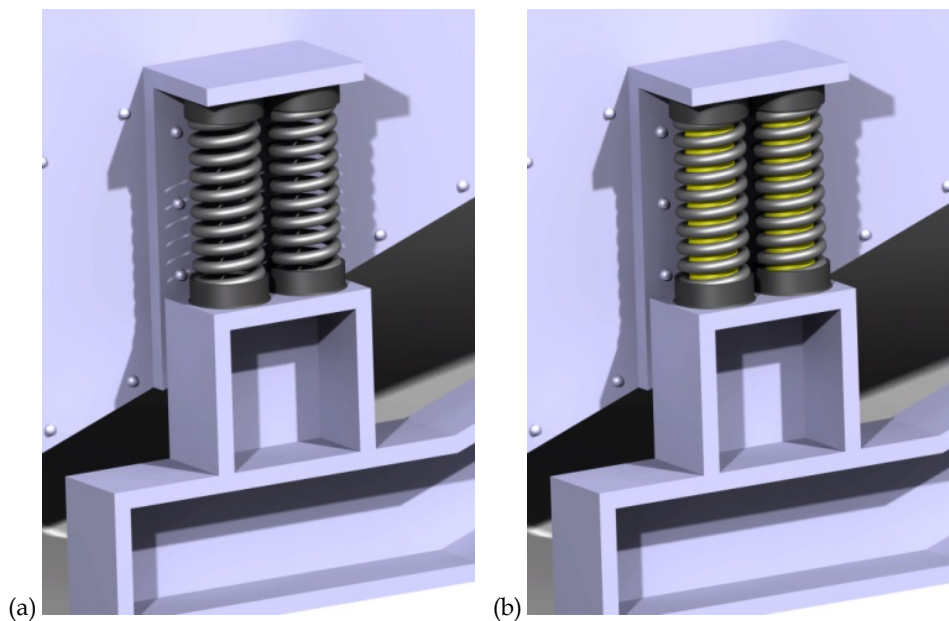

Fig. 2. 3D illustrations of the solely springs (a) and spring/dashpots (b) systems

on the speed and accuracy of the simulation process. The FEM formulation of a boundary value problem finally results in a system of algebraic equations. The method approximates the unknown function over the domain. The simple equations that model these finite elements are then assembled into a larger system of equations that models the entire problem (Logan, 2011). Since the frequency of the screen was investigated as the operational variable, to prevent the interference of the studied frequency with the natural frequencies of the screen, the natural modes of the screen were first obtained. Then, operating frequencies were selected and simulated.

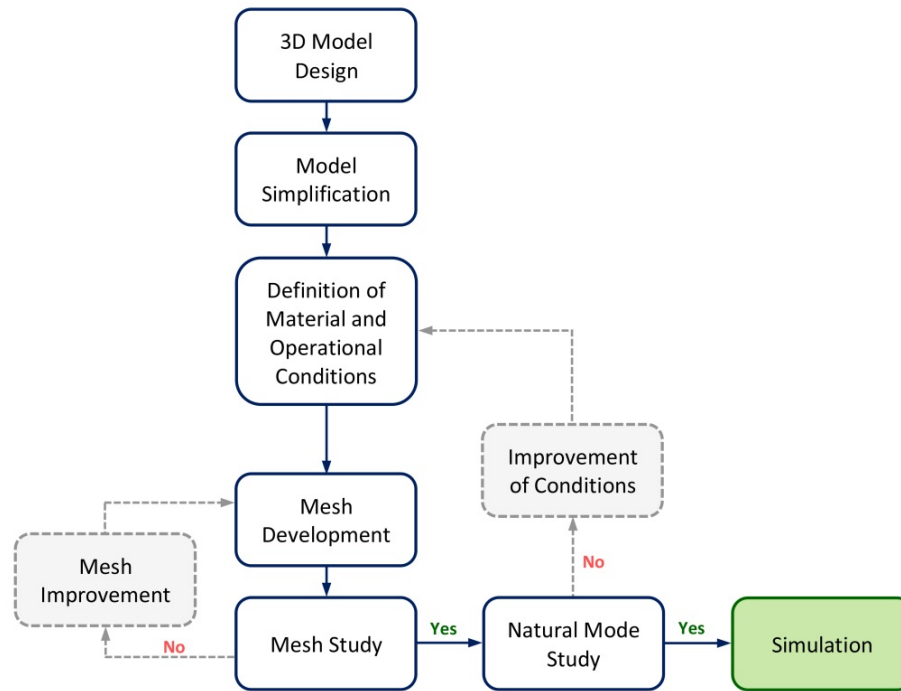

Fig. 3. Stages involved in the FEM analysis of the vibrating screen

3.1. Structural characteristics of the vibrating screen

Fig. 4a shows the structural illustration of the screen studied in this research. This screen is a 7 t/h three-deck vibrating type which works in an aggregate mine. It sorts the product of a vertical shaft impact (VSI) crusher into four classified products through polyurethane panels. All the decks are positioned at the angle of inclination of 13°. The vibration to the screen is supported by an eccentric exciter on one side of the screen body. The exciter is powered using a V-belt connected to an electric motor. The frequency and amplitude of the drive system can be adjusted by manipulating the pins on the exciter. The vibration to the screen body is supported using four similar pairs of springs on the corners of the screen sides (Fig. 1). The geometrical characteristics of the screen and springs are listed in Table 1.

Table 1. Structural and geometrical parameters of screen and its springs

Screen					
Length (mm)	Width (mm)	Height (mm)	Thickness (mm)	Distance between upper decks	Distance between lower decks
2000	1000	900	10	400	300
Springs					
Height (mm)	Outer diameter (mm)	Wire diameter (mm)	Number of rounds	Distance between springs (mm)	Distance from the screen base (mm)
300	108	16	10	130	400

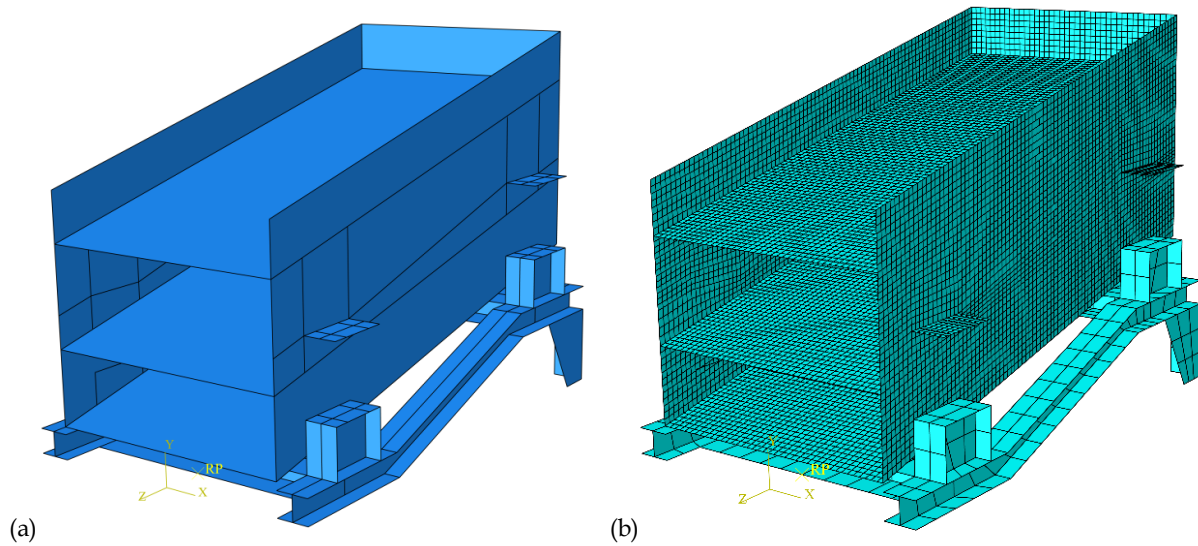

Fig. 4. 3D model (a) and meshed structure (b) of the studied vibrating screen

3.2. Applying loading and material

To minimize the time taken to run the simulation, the extra features that are not relevant to the analysis were removed. Therefore, the bases of the screen stand were fixed (Fig. 5a) and dynamic loading was described and applied to the screen structure. In addition, the bed depth which represents the height of the distributed mineral particles along the screen length was multiplied by the length and breadth in order to attain the volume of the product. Furthermore, the loads were estimated based on the bulk density of the feed to the screen, and were then converted into a uniformly distributed load, combined with the mass of the polyurethane screen panels. Fig. 5b displays the distribution of loads on the screen structure. The positions of springs on both sides of the screen frame were defined as an independent part with relevant frequency properties corresponding to springs and/or vibration absorbers (spring/dashpots) (Fig. 5c). This approach simplifies the complexity involved when these components are embedded in the CAD model of the screen structure.

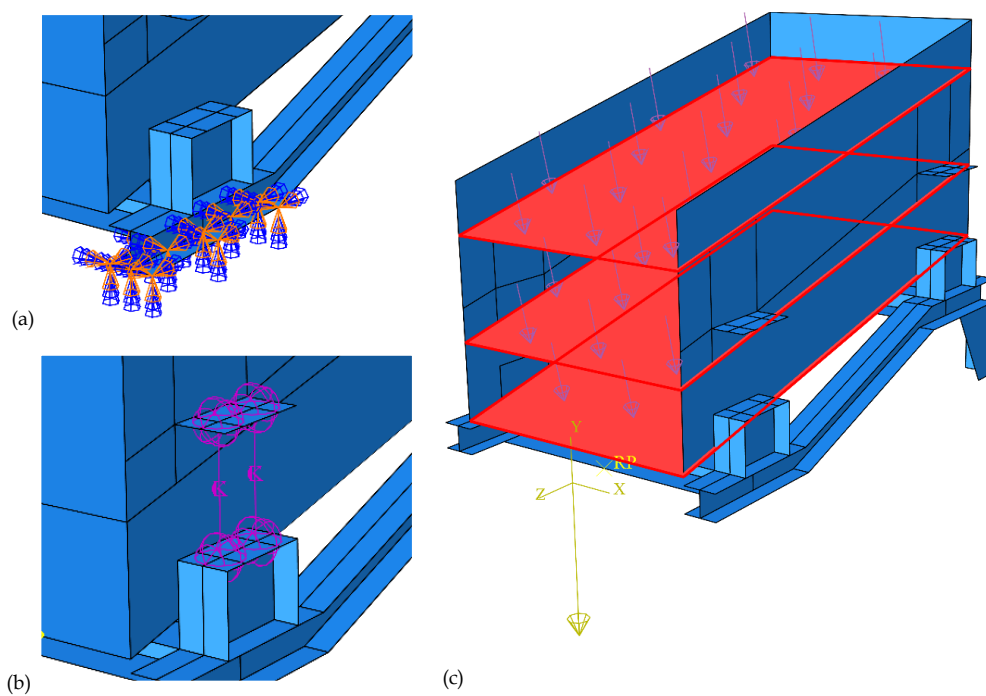

Fig. 5. Illustration of the simplifications applied to (a) screen bases, and (b) springs position, and (c) applying of loading conditions on the structure of vibrating screen

FEA always requires that a material be specified for each designed component. The material selection needs to be aligned with the type of functions that the machine will perform during its operation. For components such as vibrating motor, screen panels, and bolts, material specifications are already known, as such components are commercially available. The physical specifications of different simulation components are listed in Table 2.

Table 2. Physical characteristics of the screen structure, springs and vibration absorbers

	Material	Modulus of elasticity (GPa)	Poisson's ratio	Density (g/m ³)	Thickness (mm)
Screen structure	Carbon-Steel Sheet	200	0.28	7.8	10
Springs	mild steel	210	0.303	7.85	16
Panels	TPU	5	0.49	1.2	10
	Material	Hardness	Damping factor	Natural frequency (Hz)	Half power bandwidth (Hz)
dashpots	Rubber	Medium (33 shore)	0.075	47.39	7.109

3.3. Meshing and simulation

To analyze the screen structure, finite element analysis uses mesh prior to generating results. In this study, the structured Quad element shape was selected as the mesh type. In addition, the value of 0.1 was considered for both maximum deviation factor and fraction of global size to control the curvature and minimum size of the mesh structure. During the simulation process, the mesh size is always kept at 100% since the finer the mesh size, the more accurate the results. However, if the number of meshes is too small, accurate simulation results will not be obtained, and too many meshes will significantly increase the time required for simulation. Hence, the accuracy of the finite element analysis is dependent upon mesh refinement (Ramatsitse et al., 2017). Therefore, to select the appropriate number of meshes, mesh convergence was investigated and the optimal number of meshes was considered to be 300,000 based on the results in Table 3. The final meshed structure of the vibrating screen is depicted in Fig. 4b. According to Song et al. (2013), the dynamic analysis of the mechanical structure is the rate of change of the structural modal parameters on the design variables. The dynamic analysis in this paper was performed by keeping feed rate, bed depth, screen length and breadth constant while changing the frequency applied to the screen exciter, including 15, 23, and 27 rad/s. Prior to dynamic simulation, the modal analysis of the vibrating screen was performed to extract its natural frequency, and results are given in Table 4. Natural characteristics include natural frequency, natural vibration modes, and other modal parameters. The purpose of natural characteristic analysis is to avoid resonance and harmful vibration modes and improve the reliability and service life of the screen and screen frame (Ding et al., 2012).

Table 3. Investigation of mesh convergence in order to select the optimal number of mesh elements

Global size	Elements	Max stress	Global size	Elements	Max stress
100	1122	14.6008	9	129385	22.0798
50	4240	13.7490	8	165189	22.4731
25	17264	19.2799	7	216181	22.8138
12	73321	21.3338	6	239989	23.4306
10	106012	22.1013	5	426460	23.9929

Table 4. The results of calculating the natural frequencies of the screen examined

Mode No.	Frequency (cycles/time)	Mode No.	Frequency (cycles/time)	Mode No.	Frequency (cycles/time)
1	9.482	5	23.608	9	27.298
2	9.6272	6	23.669	10	27.997
3	11.959	7	25.975	11	35.465
4	13.015	8	27.251	12	35.522

4. Results and discussion

4.1. Dynamic analysis of solely springs system

The modal analysis of the vibrating screen was performed for each frequency in two modes, without loading and under loading. Table 5 presents the maximum stress values in the body of the vibrating screen in the absence of the vibratory absorber. It is observed that the amount of stress without loading is almost constant, but with feeding to the sieve, the amount of stress increases significantly. Note that the nonlinear trend of stress variation at different frequencies is such that the stress at frequency 23 decreases and then increases with increasing the frequency. At low frequencies, due to the reduction of particle throw rate at the panel surface and, consequently, the decreased separation efficiency, the load accumulation on the panel surface increases the stress on the screen. As the frequency increases and the particle separation rate improves, the stress also decreases, but an excessive increase in frequency increases the throw distance of the particles and, as a result, the resulting stress on the screen increases due to more particles hitting the panels. Displacement/time diagrams for the unloaded and loaded screen at different frequencies are compared in Fig. 6, showing that the displacement variations at frequency 23, especially in the loading mode, have a more uniform trend than other frequencies.

It is shown that there is a close relationship between the vibrating behavior of the screen and the throw coefficient of feed material over the screen deck (Michalczyk et al., 2017). As the frequency increases, the amount of particles thrown on the surface of the screen gradually increases and, as a result, the stress intensity on the screen decreases due to the faster discharge of the feed material from the deck end; as the frequency excessively increases, the stress on the screen increases due to the excessive increase in the amplitude of the particles. An increase in the amplitude of the particles on the deck of the screen is also observed as an irregularity in the oscillating movements of the screen. These results necessitate the maintenance of a balance between the frequency induced in the screen and the tonnage of the feed. Many companies try to maximize the capacity of the screens to improve production while not paying attention to the optimization of the mechanical condition of the screens. For example, Rotich et al. (2017) showed that under constant operating conditions, increasing the tonnage without modifying the vibration parameters of the screen can reduce the separation efficiency by over 50%.

Table 5. Results of modal analysis for the vibrating screen examined with solely springs

Spring mode	Frequency (rad/s)		
	15	23	27
Max stress /Unloading	22.1013	23.4096	22.3259
Max stress /Loading	339.163	237.062	409.675

4.2. Dynamic analysis of spring/dashpots system

To investigate the effect of frequency on the dynamic behavior of the screen, the throughput to the machine was considered to be fixed (i.e. 7 t/h), whereas in practice, industrial screens often operate at a constant frequency and, therefore, the input feed distribution on panels and stress conditions on the

screen are affected by the variations in the feeding rate. Therefore, vibration absorbers seem to be a useful solution to control stress fluctuations, which usually lead to off-motion effects and crack propagation from the position of springs. As given in Table 6, the results of the modal analysis of vibrating screen equipped with spring/dashpots system clearly show that the use of vibration absorbers can significantly moderate the stress imposed on the screen structure. However, the effect of dashpots under the unloading condition is lower. Fig. 7 compares the response waveforms of the screen with and without loading at different frequencies. It is observed that the vibration rate has decayed faster with the dashpots than without them; thus, the results confirm the significant damping effect of the dashpots. Baragetti and Villa (2014) studied the dynamic behavior of heavy loaded vibrating screens with different geometric and inertial properties using the FEM method and showed that by changing the configuration of the screens, the stress distribution in the screen also changes. In these studies, they investigated the possibility of using a damping system in the screens by modifying the simulation algorithm and reported that using a vibration control mechanism can significantly improve the dynamic behavior of the industrial screen. The results of our study are consistent with the simulation results of Baragetti and Villa (2014) regarding the improvement of the vibration pattern in the screen in the presence of a damping system.

Table 6. Results of modal analysis for the vibrating screen examined with spring/dashpots

Spring/Dashpots mode	Frequency (rad/s)		
	15	23	27
Max stress /Unloading	20.0642	20.0283	18.1037
Max stress /Loading	267.57	97.4989	233.756

A comparison of Figs. 6 and 7 show the initial irregularity in the displacement diagrams shortly after the start-up of the dashpot-equipped screens. This effect can be attributed to the resonance phenomenon in the plastic dashpot, which is caused by the initial driving force transmitted from the exciter to the screen. These results are in agreement with the findings of Iwata et al. (2016) who investigated the effect of using dampers on the performance of springs of a vibration system equipped with 2-5 vibrators using numerical simulation and differential evolution (DE) method. They reported that the use of vibration absorbers significantly improves the vibration amplitude of systems equipped with springs. In addition, according to the figure, by using the vibrating absorber, irregular motion can be converted into harmonic motion, and the occurrence of fatigue and failure in the screen structure can be expected to be delayed.

4.3. Modal analysis of the vibrating screen

To investigate the effect of vibration absorbers on stress distribution in different parts of the screen structure, a simple finite element analysis at frequency 23 was performed and the results are illustrated in Fig. 8. In the absence of dashpots, the stress distribution in different parts of the sieve is non-uniform and most of the stress is applied to the lower deck of the sieve. Nevertheless, in the screen equipped with the spring/dashpots system, the imposed stress is evenly distributed in all parts of the screen. In this case, the maximum stress is applied to the springs' connection points to the body of the screen, and this confirms the outstanding damping performance of the dashpots. These results are in agreement with the findings reported by Shirazi (2019) (Fig. 9). He investigated the effect of stress distribution on the wear pattern of different decks of a 32 m² vibrating screen with a capacity of 800 t/h and concluded that the highest wear rate occurs in the lower deck of the screen (Fig. 9). He interpreted these results as follows: The particle throw rate, especially on the initial panels of the upper deck, is low due to the heavy weight of the fresh feed and, therefore, the stress on the screen is reduced. During the movement of the feed load towards the discharge end of the upper floor, the throw of the particles gradually increases due to the initial separation and the decrease of the particle compaction. On the lower deck of

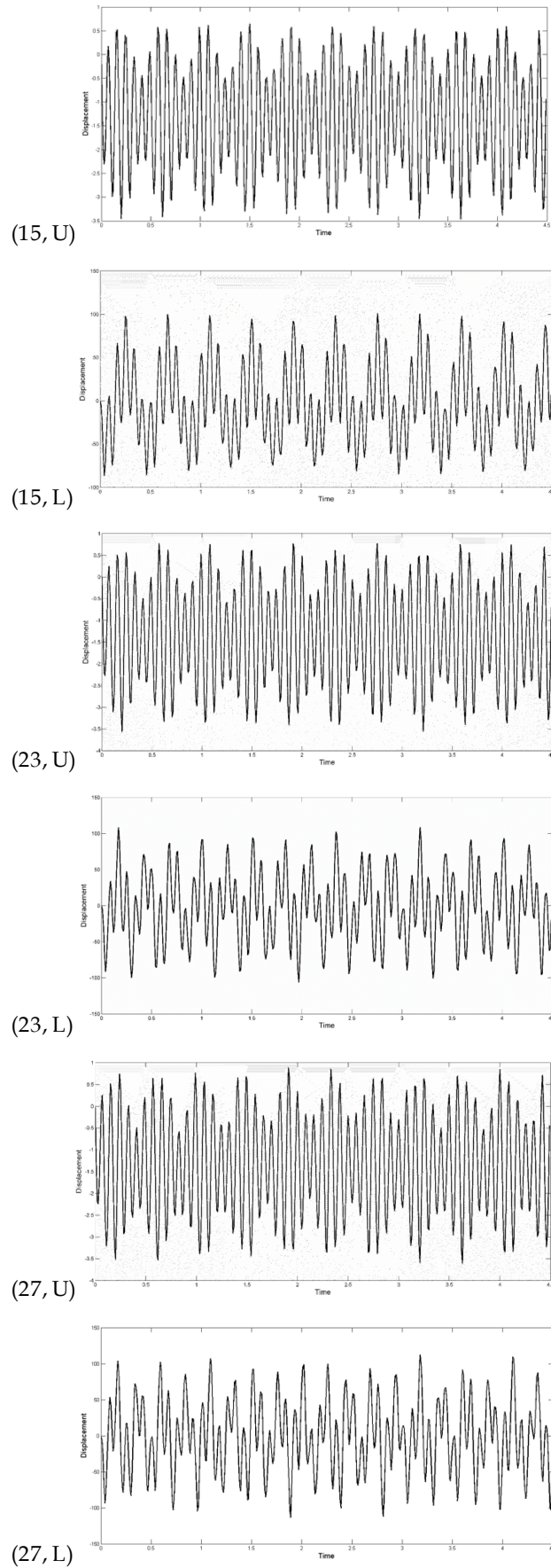

Fig. 6. Dynamic responses of vibrating screen with solely springs under various operating conditions: (Frequency value ~ No., Unloaded ~ U or Loaded ~ L)

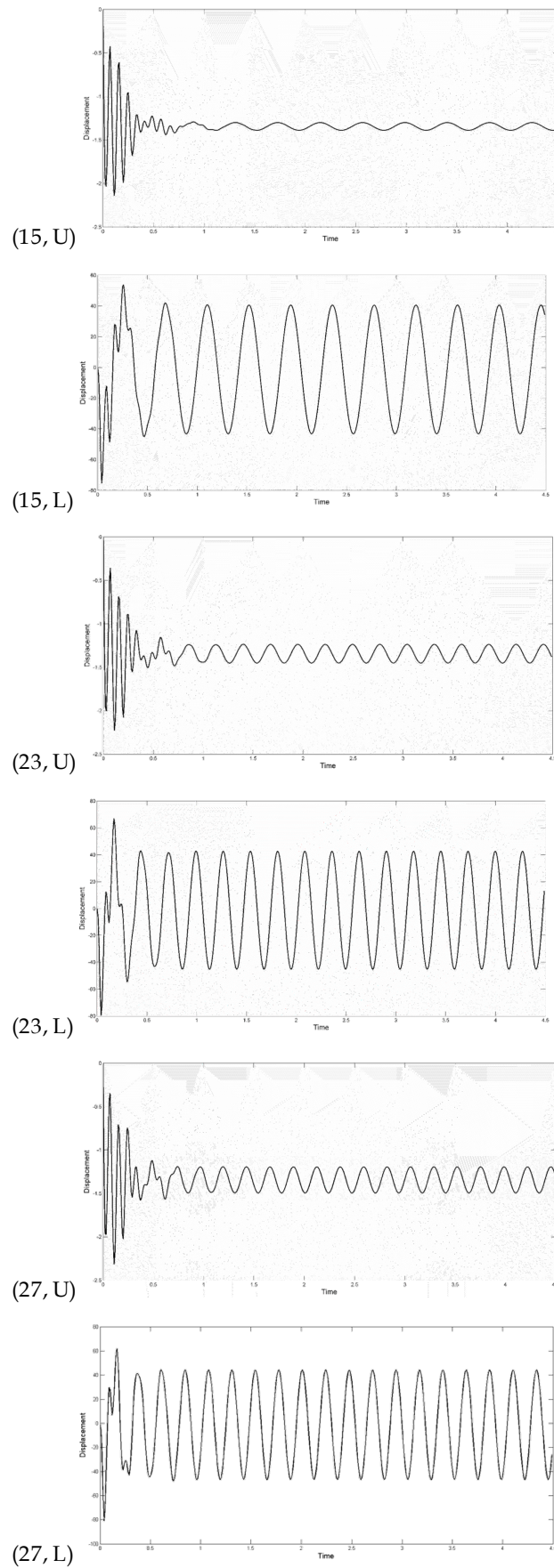

Fig. 7. Dynamic responses of vibrating screen with spring/dashpots system under various operating conditions: (Frequency value ~ No., Unloaded ~ U or Loaded ~ L)

the screen, due to the lower throughput, the amplitude of the particle thrown increases again and the stress increases along the deck. In Fig. 8, the dynamic response of the screen is displayed at 10x magnification, and it is clear that all-round vibrations in the screen are dramatically controlled when vibrating absorbers are used. Thus, it can be expected that dashpots should play a very effective role in preventing the screen from cracking, moving, and loosening the panels; avoid uneven distribution of particles' stream along the screen decks and, consequently, the reduction of classification efficiency; and have other effects caused by the off-motion phenomenon.

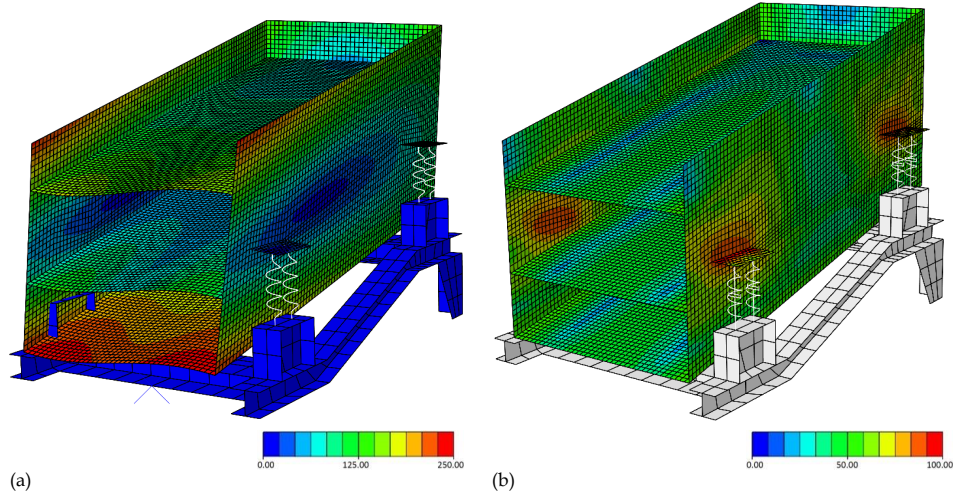

Fig. 8. Finite element analysis of the screen structure with solely springs (a) and with spring/ dashpots system (b)

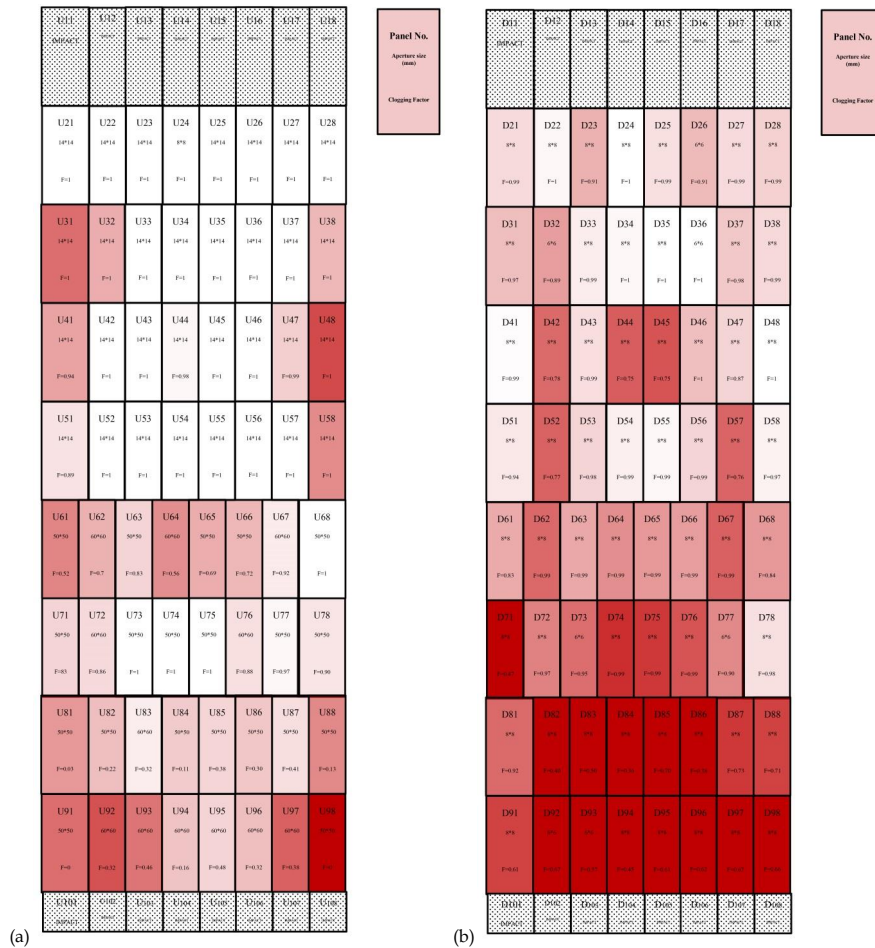

Fig. 9. Wear pattern in the upper (a) and lower (b) decks of 32 m² vibrating screen; the colour intensity is proportional to the wear rate (Shirazi, 2019)

5. Conclusions

Despite the key role of vibration in the operating performance of vibrating screens, inadequate dynamic conditions of screens can lead to adverse consequences such as unbalanced motions, cracking of the body or side planes of the screen, and process inefficiencies. Thus, considerable effort has been made to optimize and control the design and working conditions of the screens through experimental and simulation approaches. Since springs are one of the main components of vibration control in vibrating screens, modifying or changing the system of these components can directly affect the improvement of the vibration performance of the screen. Given this important point, in this study, the feasibility of dashpots' application to the vibration system of a medium-sized vibrating screen was assessed using FEM. The results revealed that the use of dashpots can significantly damp the stress imposed on the screen body by uniform stress distribution in all parts of the machine. Moreover, vibration absorbers significantly modify the irregular vibrational motions of the screen into harmonic motion. These findings confirm the positive damping effect of dashpots to prevent potential damages to the screen body such as structure cracking, displacement of the panels, and reduction of separation efficiency. However, the results reported in the present work are based on numerical simulation; thus, further experimental investigations need to be considered to confirm the practical applicability of the results.

Acknowledgments

The authors wish to thank Rayhanshahr aggregate mine (Zarand, Iran) for the technical support of the research project.

References

- BARAGETTI, S., VILLA, F., 2014. *A dynamic optimization theoretical method for heavy loaded vibrating screens*, *Nonlinear Dyn.* 78, 609–627.
- CHANDRAVANSHI, M.L., MUKHOPADHYAY, A.K., 2017. *Analysis of variations in vibration behavior of vibratory feeder due to change in stiffness of helical springs using FEM and EMA methods*, *J. Braz. Soc. Mech. Sci. Eng.* 39, 3343–3362.
- CHANDRAVANSHI, M.L., MUKHOPADHYAY, A.K., 2017. *Dynamic analysis of vibratory feeder and their effect on feed particle speed on conveying surface*, *Measurement*. 101, 145–156.
- DING, C., SONG, F., SONG, B., MEN, X., 2012. *The finite element analysis of vibrating screen*, *Appl. Mech. Mater.* 141, 134–138.
- GAO, G.L., 2012. *A new single degree-of-freedom resonance device*, *J. Cent. South Univ.* 19, 2782–2787.
- IWATA, Y., KOMATSUZAKI, T., KITAYAMA, S., TAKASAKI, T., 2016. *Study on optimal impact damper using collision of vibrators*, *J. Sound Vib.* 361, 66–77.
- JIANG, H., ZHAO, Y., DUAN, C., LIU, C., WU, J., DIAO, H., LV, P., QIAO, J., 2017. *Dynamic characteristics of an equal-thickness screen with a variable amplitude and screening analysis*, *Powder Technol.* 311, 239–246.
- KELLY, E.G., SPOTTISWOOD, D.S., 1982. *Introduction to Mineral Processing*. John Wiley & Sons Inc., USA.
- LOGAN, D.L. 2011. *A First Course in the Finite Element Method*. Cengage Learning, USA.
- MICHALCZYK, J., CIEPŁOK, G., 2016. *Maximal amplitudes of vibrations of the suspended screens during the transient resonance*, *Arch. Min. Sci.* 61, 537–552.
- MICHALCZYK, J., BEDNARSKI, Ł., GAJOWY, M., 2017. *Feed material influence on the dynamics of the suspended screen at its steady state operation and transient states*, *Arch. Min. Sci.* 62(1), 145–161.
- PARLAR, J., 2010. *Vibration Analysis & Vibrating Screens: Theory & Practice*. PhD. Thesis, McMaster University, Hamilton, Ontario.
- PENG, L., FANG, R., FENG, H., ZHANG, L., MA, W., HE, X., 2018. *A more accurate dynamic model for dual-side excitation large vibrating screens*, *J. Vibroeng.* 20, 858–871.
- PENG, L., JIANG, H., CHEN, X., LIU, D., FENG, H., ZHANG, L., ZHAO, Y., LIU, C., 2019. *A review on the advanced design techniques and methods of vibrating screen for coal preparation*, *Powder Technol.* 347, 136–147.
- PENG, L.P., LIU, C.S., 2015. *Stiffness identification of four-point-elastic-support rigid plate*, *J. Cent. South Univ.* 22, 159–167.
- PENG, L.P., LIU, C.S., LI, J., WANG, H., 2014. *Static-deformation based fault diagnosis for damping spring of large vibrating screen*, *J. Cent. South Univ.* 21, 1313–1321.

- RAMATSETSE, B.I., MATSEBE, O., MPOFU, K., DESAI, D.A., 2013. *Conceptual design framework for developing a reconfigurable vibrating screen for small and medium mining enterprises*, SAIIE25 Proceedings, Stellenbosch, South Africa.
- RAMATSETSE, B., MPOFU, K., MAKINDE, O., 2017. *Failure and sensitivity analysis of a reconfigurable vibrating screen using finite element analysis*, Case Stud. Eng. Fail. Anal. 9, 40–51.
- RAMATSETSE, B., MPOFU, K., MAKINDE, O.A., 2019. *Analysis and performance investigation of a reconfigurable vibrating screen machine for mining and mineral processing industries*, Procedia CIRP 84, 936–941.
- RODRIGUEZ, C.G., MONCADA, M.A., DUFEU, E.E., RAZETO, M.I., 2016. *Nonlinear model of vibrating screen to determine permissible spring deterioration for proper separation*, Shock. Vib., 1–7.
- ROTICH, N., TUUNILA, R., ELKAMEL, A., LOUHI-KULTANEN, M., 2017. *Dynamic and perturbative system analysis of granular material in a vibrating screen*, Adv. Powder Technol. 78, 3257–3264.
- SHIRAZI, A.R., 2019. *Optimization of secondary screens at the Gohar Zamin Iron Ore Complex*, Technical Report, Sirjan, Iran.
- SLEPYAN, L.I., SLEPYAN, V.I., 2014. *Coupled mode parametric resonance in a vibrating screen model*, Mechanical Syst. Signal Process. 43, 295–304.
- SOLDINGER, M., 1999. *Interrelation of stratification and passage in the screening process*, Miner. Eng. 12, 497–516.
- SOLDINGER, M., 2002. *Transport velocity of a crushed rock material bed on a screen*, Miner. Eng. 15, 7–17.
- SONG, B., SONG, F.Z., DING, C.G., 2013. *Vibration sensitivity analysis of the secondary isolation support*, Appl. Mech. Mater. 278–280, 18–22.
- VERGNANO, A., BERSELLI, G., PELLICCIARI, M., 2017. *Parametric virtual concepts in the early design of mechanical systems: a case study application*, Int. J. Interact. Des. Manuf. 11, 331–340.
- WANG, L., DING, Z., MENG, S., ZHAO, H., SONG, H., 2017. *Kinematics and dynamics of a particle on a non-simple harmonic vibrating screen*, Particuology. 32, 167–177.
- WANG, G., TONG, X., 2011. *Screening efficiency and screen length of a linear vibrating screen using DEM 3D simulation*, Min. Sci. Technol. 21, 451–455.
- WILLS, B.A., NAPIER-MUNN, T.J., 2007. *Wills' Mineral Processing Technology*. 7th ed., Elsevier, England.
- XIONG, X., NIU, L., GU, C., WANG, Y., 2017. *Vibration characteristics of an inclined flip-flow screen panel in banana flip-flow screens*, J. Sound Vib. 411, 108–128.
- YANTEK, D.S., LOWE, M.J., 2011. *Analysis of a mechanism suspension to reduce noise from horizontal vibrating screens*, Noise Control Eng. J. 59, 568–580.
- ZHANG, X., WEN, B., ZHAO, C., 2017. *Vibratory synchronization transmission of a cylindrical roller in a vibrating mechanical system excited by two exciters*, Mech. Syst. Signal Process. 96, 88–103.
- ZHANG, Z., 2016. *Strain modal analysis and fatigue residual life prediction of vibrating screen beam*, J. Measur. Eng. 4, 217–223.
- ZHAO, Y., LIU, C., HE, X., ZANG, C., WANG, Y., REN, Z., 2009. *Dynamic design theory and application of large vibrating screen*, Procedia Earth Planet. Sci. 1(1), 776–784.
- ZHAO, L., ZHAO, Y., LIU, C., LI, J., DONG, H., 2011. *Simulation of the screening process on a circularly vibrating screen using 3D-DEM*, Min. Sci. Technol. 21(5), 677–680.
- ZHOU, Z., HUANG, L., JIANG, H., WEN, P., ZHAO, L., ZHAO, Y., DUAN, C., LUO, Z., WANG, Z., LIU, C., ZIMING, W., 2019. *Kinematics of elastic screen surface and elimination mechanism of plugging during dry deep screening of moist coal*, Powder Technol. 346, 452–461.
- ZHU, H., GE, S., YU, X., 2004. *A novel low-noise vibrating screen*, Coal Prep. 24, 85–96.