

INFLUENCE OF TOOTHED GEAR GEOMETRY PARAMETERS ON POWER TRANSMISSION SYSTEM VIBROACTIVITY

Grzegorz Peruń, Jarosław Kozuba

Silesian University of Technology
Kraśińskiego Street 8, 40-019 Katowice, Poland
tel.: +48 32 603 4140, fax: +48 32 603 4108
e-mail: grzegorz.perun@polsl.pl, jaroslaw.kozuba@polsl.pl

Abstract

The article presents selected results of experimental studies on the influence of chosen factors on the dynamic effects and vibroactivity of toothed gears in power transmission systems. The studies were performed on test stand with the gears operating in the circulating power system. On initial phase of the research, four pairs of helical gear wheels with the same value of gear ratios were designed and manufactured. The wheels differed by values of transverse contact ratio ε_α , face contact ratio ε_β and total contact ration ε_C . In the research, the transverse vibration velocities of the shafts and housing of the tested toothed gear on FZG test stand was assumed to be the vibroactivity criterion. The measurements of the vibrations were carried out on the shafts and at seven points of the top plate of the housing. The vibrations were measured using a laser vibrometer and acceleration sensors. In addition, selected experimental results of measurements were compared with results of numerical simulations. To the simulations was used extended, identified dynamic model of the FZG test stand. The parameters of the wheels and the measured deviations were introduced into model. Obtained results confirm that by increasing the value of the contact ratio of the helical gear is possible reduction of dynamic phenomena occurring in the toothed gear.

Keywords: power transmission system, vibroactivity, toothed gear

1. Introduction

The main goal of the realized laboratory studies was experimental verification of ways of vibroactivity reduction of toothed gear working in power transmission system. Second aim of research was verification of simulations results and correctness of identification of the dynamic model [1, 6-8] of the toothed gear working in power transmission system.

On initial phase of the research, four pairs of helical gear wheels with the same value of gear ratios were designed and manufactured. The wheels differed by values of transverse contact ratio ε_α , face contact ratio ε_β and total contact ration ε_C . Wheels used in laboratory experiments are shown in Fig. 1.

The measured pitch, profile and helix deviations of wheels respond to the 6. accuracy class. The dynamic tests of helical gears has proven that the increase of the contact ratio causes the decrease of the dynamic load of the gear wheels and therefore also of the load of bearing nodes. Taking into account the results of the above-mentioned research [5, 9] it has been assumed that the increase of the contact ratio of the helical gear causes also the decrease in the vibroactivity of the gear.

Evaluation of the vibroactivity will be performed on the basis of the measurements of the vibration velocity in the shafts and in the housing of tested gear in which individual wheel pairs were, being installed [2-4, 9]. The FZG test stand together with the measurement and recording instruments are shown in Fig. 2.

2. Research object

In the research, the transverse vibration velocity of the shafts and housing of the tested toothed gear on FZG test stand was assumed to be the vibroactivity criterion. The measurements of the

normal vibration velocities were carried out at seven points of the top plate of the housing, as specified in Fig. 3.

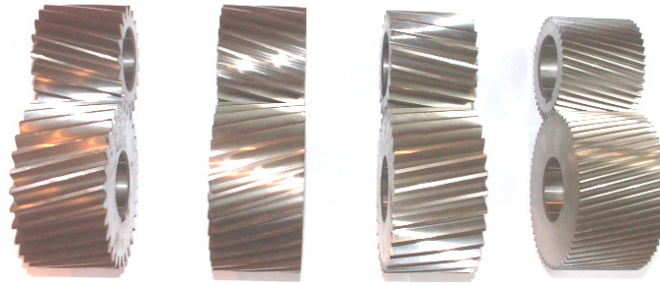

Fig. 1. Toothed wheels used in the study [7, 10]

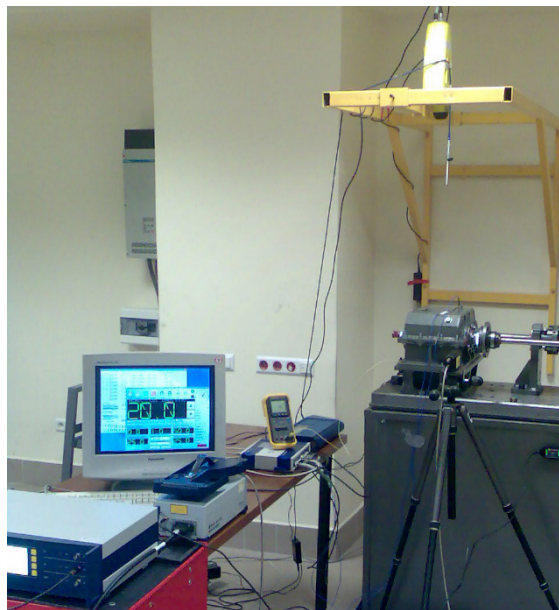

Fig. 2. Test stand FZG with measurement and recording instruments [7]

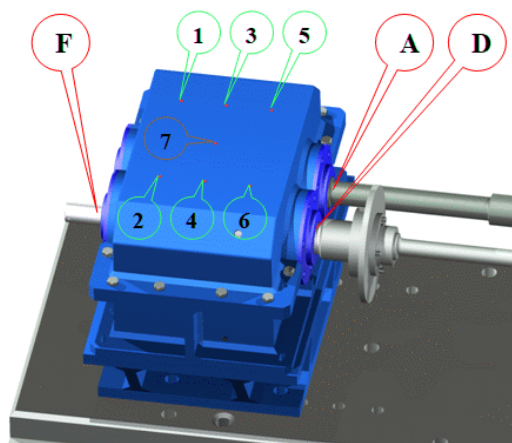

Fig. 3. Locations of the measurement points on the tested toothed gear [7]

The measurements of shafts vibration were taken with use Ometron VH300+ laser vibrometer in point A, D and F (Fig. 3). In addition, a reference signal corresponding to the instantaneous position of the pinion and gear wheel shafts was registered, allowing the determination of the period of the mating cycle of the teeth of both wheels. Reference signals were generated by

a digital circuit working with optoelectronic sensors mounted in the vicinity of the toothed gear shafts. Sampling frequency of measured signals was equal 78 [kHz]. The registered signals were averaged and filtered. The harmonic components with frequencies higher than 5 kHz were from signals filtered off.

Experiments were realized at two unit loads: $Q = 1$ and 2.15 [MPa] in wide range of rotational velocities. Oil temperature in toothed gear was maintained in a range $45 \pm 5^\circ\text{C}$. The basic parameters of gear wheel pairs mounted during experiment in tested gear of FZG test stand are presented in Tab. 1.

Tab. 1. The geometrical parameters of the wheels mounted in the tested gear of the FZG test stand

	Gear wheel pair no. 1	Gear wheel pair no. 2	Gear wheel pair no. 3	Gear wheel pair no. 4
Number of pinion teeth, z_1 [-]	19	19	19	38
Number of wheel teeth, z_2 [-]	30	30	30	60
Module, m [mm]	3.5	3.5	3.5	1.75
Transverse pressure angle, α_{on} [$^\circ$]	20	20	20	20
Helix angle, β [$^\circ$]	11.333	15	18	15
Axis distance, a_w [mm]	91.5	91.5	91.5	91.5
Transverse contact ratio, ε_α [-]	1.239	1.332	1.426	1.4
Face contact ratio, ε_β [-]	1.001	1.318	1.574	2.636
Total contact ratio, ε_C [-]	2.24	2.65	3	4
Pinion profile shift coefficient, x_1 [-]	0.630	0.5	0.170	0.794
Wheel profile shift coefficient, x_2 [-]	0.633	0.295	0.171	0.795
Gear mesh width, b_w [mm]	56	56	56	56

3. Results of research

The influence of the selected construction parameters on the vibroacoustic properties of the gear was investigated by the analysis of the changes of RMS values of the transverse vibration velocities of the shafts and the RMS values of the housing vibration velocity.

In addition, experimental results were compared with results of numerical simulations. To the simulations was used extended, identified dynamic model of the FZG test stand. The parameters of the wheels and the measured deviations were introduced into model. The transverse vibration velocity values obtained from simulations were compared with the corresponding measurement results obtained using the laser vibrometer.

Comparison of the RMS values of the transverse vibration velocity of the gear wheel shaft in point D (Fig. 3) measured at FZG test stand using a laser vibrometer and obtained from the model are shown on Fig. 4 as a function of the rotational velocity.

RMS values of the transverse vibration velocity of the shafts decrease as the pitch contact ratio ε_β increases.

The housing vibrations were measured using a laser vibrometer directly at point 7 as well as using the acceleration sensors mounted subsequently at points 1-6. The acceleration values were integrated and then filtered (due to the low frequency harmonic components strongly modulating the vibration frequency values), for removing the harmonics with frequency below 2.5 Hz.

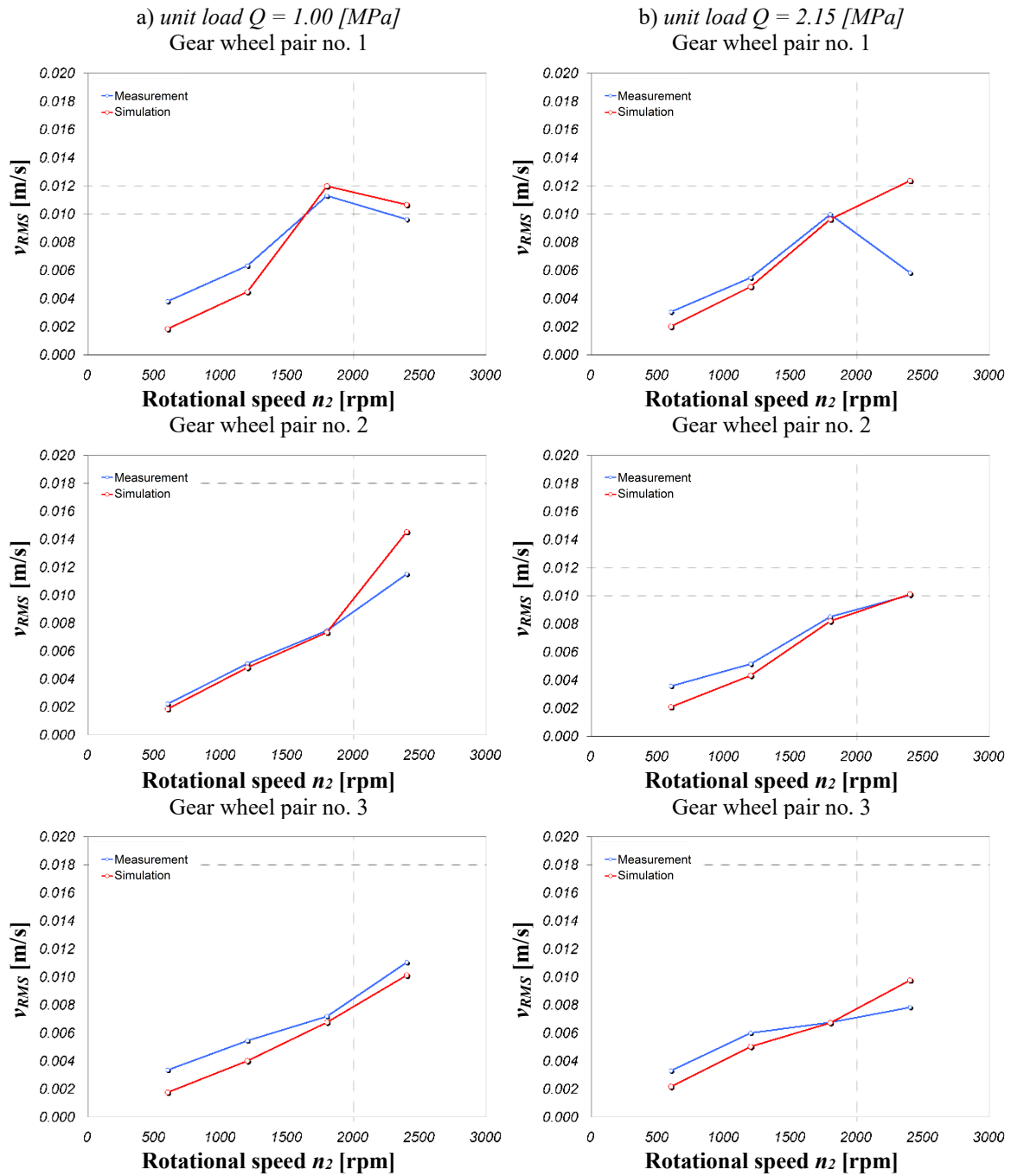

Fig. 4. The comparison of the RMS values of the transverse vibration velocity of the wheel shaft (point D) measured at FZG test stand and obtained from simulation for two unit load values [7]

On the basis of RMS values v_1 - v_6 of vibration velocities of housing in points 1-6, value of proposed measure v_6 was determined [10]:

$$v_6 = \frac{1}{N} \sum_{i=1}^N v_i, \tag{1}$$

where N – number of measurement points, N= 6.

Comparison of measure v_6 values for all pairs of gears, in examined range of rotational velocities and for both unit loads is shown in function of total contact ratio on Fig. 5 and in function of rotational velocity on Fig. 6.

The presented results allow stating that the strongest vibration of the housing occurs when gear wheel pairs no. 1 and no. 2 are mounted. The gear operating with gear wheel pairs no. 3 or no. 4

show lower vibroactivity, depending on the operating conditions such as the rotational speed and the load.

Independently from measured signal, characteristics determined on the basis of housing vibration accelerations at points 1 to 6 and on the basis of housing vibrations velocities in point 7, are comparable.

More information delivers RMS values of housing vibration velocities measured in point 7, calculated in time intervals from non-averaged signals for non-stationary conditions. For higher value of unit load, obtained results are presented on Fig. 7.

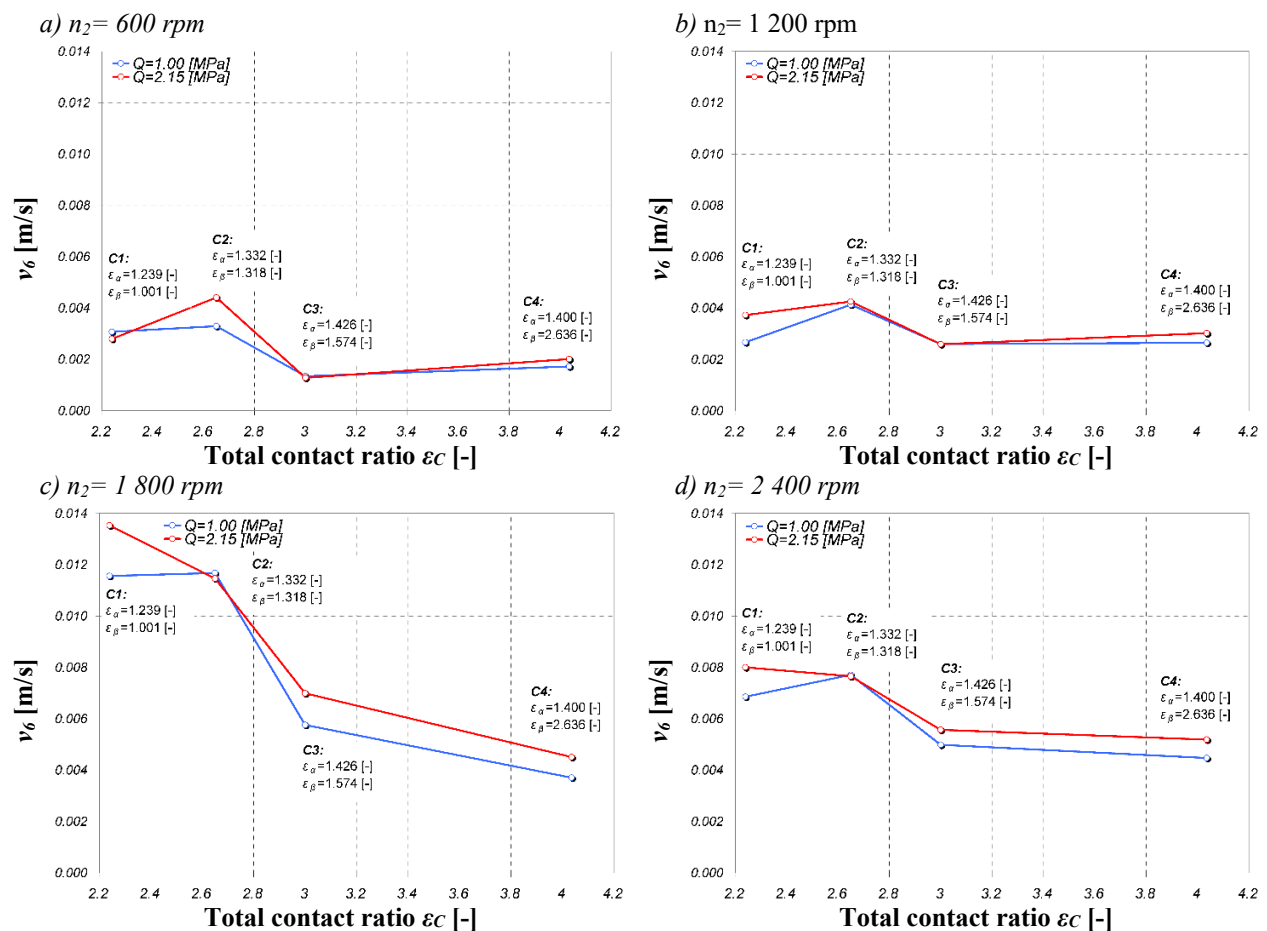

Fig. 5. The relationship of the RMS value of the housing vibration velocity at measurement points as a function of the total contact ratio – measurement at FZG test stand [7]

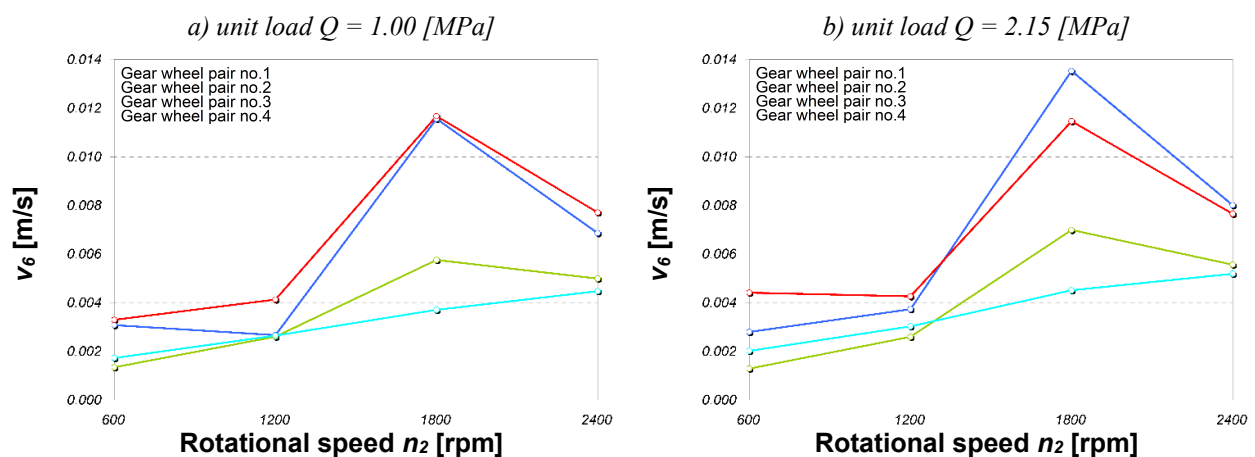

Fig. 6. Mean of RMS values of housing vibration velocities for two-unit load and four rotational velocities values [7]

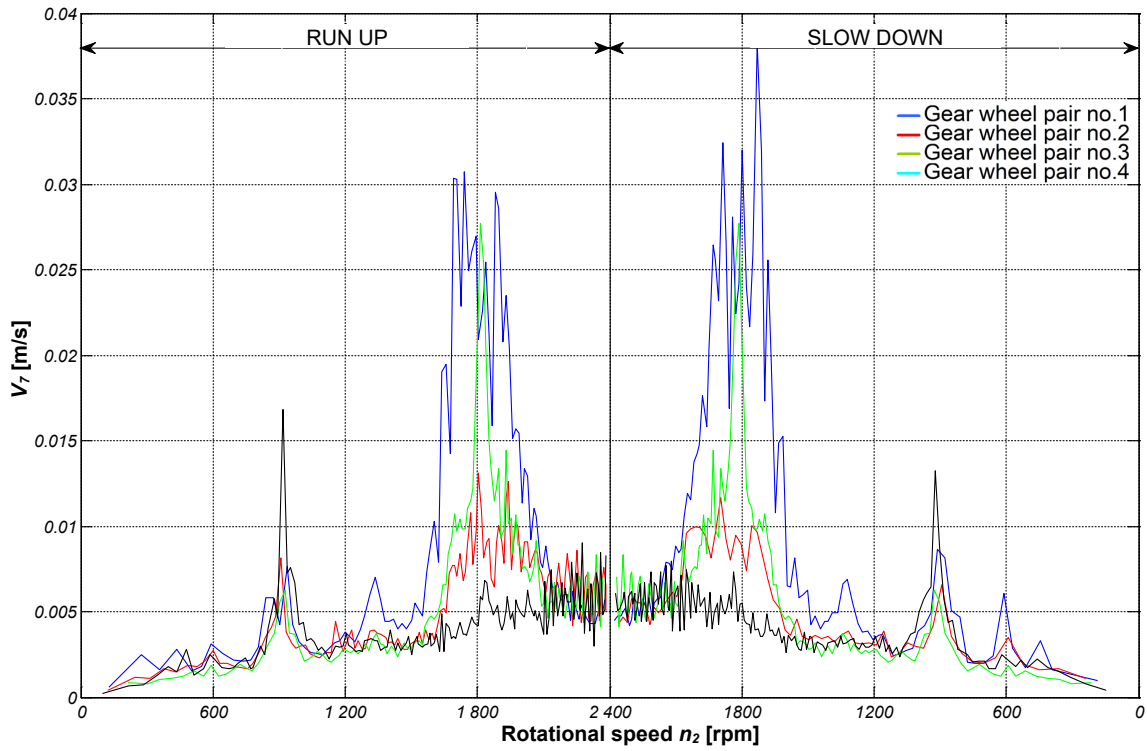

Fig. 7. The comparison of the RMS values of the transverse vibration velocities of the wheel shaft (point 7) measured at FZG test stand unit load 2.15 MPa

Frequency – rotational velocity distributions, obtained for gear wheel pair no. 1 and 4 are presented on Fig. 8 and 9.

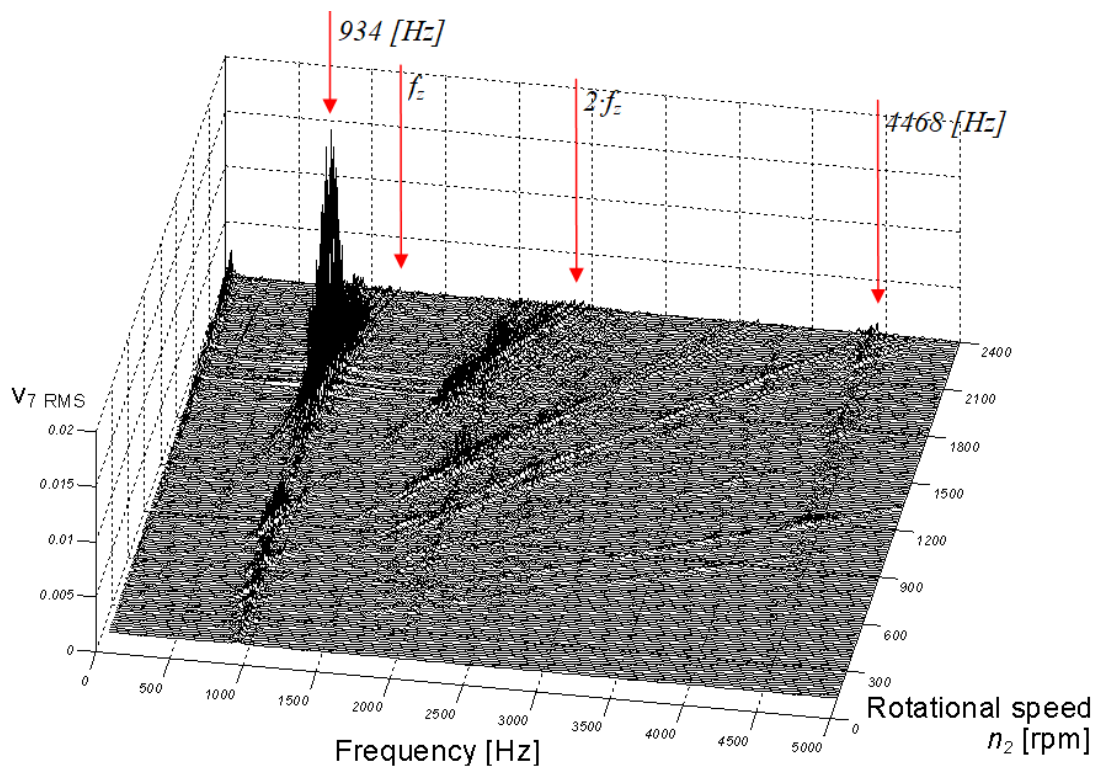

Fig. 8. The frequency – rotational velocity distribution of RMS values of vibration velocities of housing in point 7 obtained for gear wheel pair no. 1; unit load 2.15 MPa

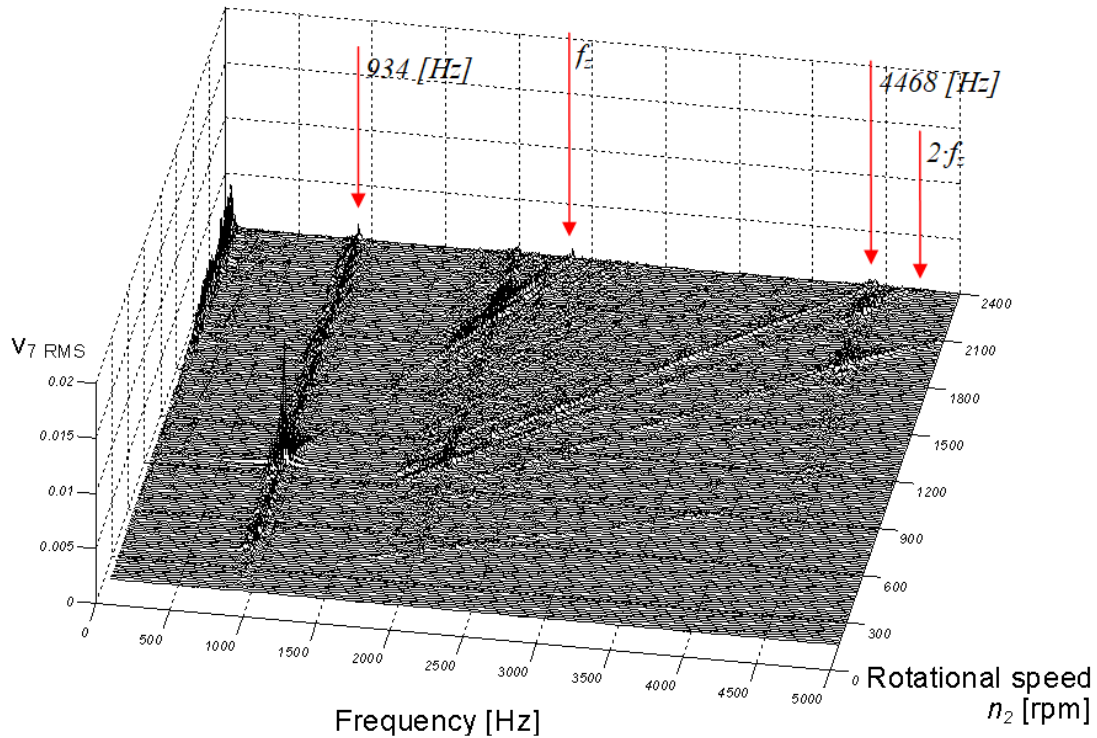

Fig. 9. The frequency – rotational velocity distribution of RMS values of vibration velocities of housing in point 7 obtained for gear wheel pair no. 4; unit load 2.15 MPa

4. Conclusions

Analysis of the results of all the measurements shows that the best vibroacoustic properties from all used in research has toothed gear with mounted gear wheel pair no. 3 or no. 4. In the largest number of cases, corresponding to different rotating speeds and loads were obtained for these pairs of gears lowest RMS values of transverse velocity of shafts and vibration of the housing. This confirms that by increasing of the contact ratio of the helical gear is possible reduction of vibroactivity of the toothed gear.

The comparison of the RMS values of the transverse vibration velocity in the wheel shaft measured at FZG test stand and obtained from simulation confirm that the developed, extended dynamic model was properly identified. On this basis it can be concluded that also forces in the bearings obtained from the simulation correspond to the forces occurring in the real gear and can therefore be used as input data for FEM models of the housing.

References

- [1] Łazarz, B., Peruń, G., *Identification and verification of simulation model of gears working in circulating power system*, Diagnostyka, No. 4(52), 55-60, 2009.
- [2] Łazarz, B., Peruń, G., *Influence of construction factors on the vibrational activity of the gearing*, Transport Problems, T. 7, Z. 2, pp. 95-102, 2012.
- [3] Łazarz, B., Peruń, G., *Wykorzystanie modelu przekładni zębatej w układzie mocy krążącej do oceny wibroaktywności korpusu*, XXIV Sympozjon PKM, Białystok–Białowieża, 2009.
- [4] Madej, H., *Minimalizacja aktywności wibroakustycznej korpusów przekładni zębatych*, Wydawnictwo i Zakład Poligrafii Instytutu Technologii Eksploatacji, Katowice – Radom 2003.
- [5] Niemann, G., Winter, H., *Maschinenelemente. Band II: Getriebe allgemein, Zahnradgetriebe – Grundlagen, Stirnradgetriebe*, Springer – Verlag, Berlin 2003.

- [6] Peruń, G., *Toothed gear dynamic model as a tool for assist diagnosis its technical condition*, Solid State Phenomena, Vol. 236, pp. 228-235, 2015.
- [7] Peruń, G., *Wpływ czynników konstrukcyjnych, technologicznych i eksploatacyjnych na wibroaktywność układu napędowego z przekładnią zębatą*, Rozprawa doktorska, Politechnika Śląska, Katowice 2010.
- [8] Peruń, G., Łazarz, B., *Modelling of power transmission systems for design optimization and diagnostics of gear in operational conditions*, Solid State Phenomena, Vol. 210, pp. 108-114, 2014.
- [9] Przybylski, J., *Wpływ liczby przyporu na nadwyżki dynamiczne w kołach o zębach skośnych*, Rozprawa doktorska, Politechnika Śląska, Gliwice 1971.
- [10] Wilk, A., Madej, H., Łazarz, B., *Vibroactivity of the gear. Influence of design characteristics and wear on the vibroactivity of power transmission system with gear*, ITE, Katowice-Radom 2009.