



Quarterly peer-reviewed scientific journal

ISSN 1505-4675
e-ISSN 2083-4527

TECHNICAL SCIENCES

Homepage: www.uwm.edu.pl/techsci/



BIM TECHNOLOGY IN GEOTECHNICAL ENGINEERING IN TERMS OF IMPACT HIGH BUILDING “MOGILSKA TOWER” IN CRACOW OF EXISTING BUILDING DEVELOPMENT

Dariusz Szwarek, Elżbieta Pilecka

Faculty of Civil Engineering
Cracow University of Technology

Received 18 March 2016, accepted 20 June 2017, available online 22 June 2017.

Key words: BIM, deep excavation, high building, settlement, influence of excavation, FEM.

Abstract

The article presents the use of BIM design method in geotechnical issues. BIM was used in the modeling of high building “Mogilska Tower” in Cracow. The object, as one of the few in Cracow, will have three underground storeys. High building with underground levels requires checking the impact of the implementation of a deep excavation on existing buildings. Analysis of settlement impact caused by deep excavation and the planned load of the building is based on the guidelines contained in the ITB (KOTLIŃSKI, WYSOKIŃSKI 2002) standards by the simplified method and detailed method determined on the basis of numerical analysis. The article presents the results of the vertical deformation of ground adjacent to the existing object. The results of the calculations were compared with the limit values shown in ITB and PN-81/B-03020 (1985). Numerical analysis was performed in the spatial state of stress and strain model. It takes into account the spatial layout of the geotechnical subgrade and the terrain shape obtained by the measurement of terrestrial laser scanner. Subgrade was modeled elastic-plastic model of Mohr-Coulomb with linear condition of plasticity. Identified the influence and range of deep excavation and loads of the planned high building on existing development.

Correspondence: Dariusz Szwarek, Wydział Inżynierii Lądowej, Politechnika Krakowska im. Tadeusza Kościuszki, ul. Warszawska 24, 31-155 Kraków, phone: 12 628 25 66, e-mail: dszwarek@pk.edu.pl

Introductions

Building Information Modeling assumptions

The use of Building Information Modeling (BIM) in the construction industry, is currently the fastest growing new concept of obtaining and collecting data at every stage of design, modeling and implementation of buildings. The resulting data is used to update the assumptions during the construction projects. A new feature of the approach, assumptions using BIM methods, is another way of collecting data. The data are collected not only from the cycle of design and construction of the object, but also after its construction and during the exploitation until the decommissioning of buildings (TOMALA 2016). It means that, data set in the concept of the method of BIM relate to each object lifecycle. These are not only parametric data model elements, taking into account the design, material and geometry of a particular item, for example characteristic of 3D modeling reinforced concrete beam. Also, it may be data on time execution of individual tasks on a construction site related by the stages of the object (4D models). BIM models allow to take into account cost management object (5D models). In the concept of BIM methods, deserve attention the information provided directly from the construction site (6D models), or during exploitation of a building (7D models) (TOMALA 2016). BIM is a comprehensive set of information about the building. Its containing a huge amount of data. They are made available to the various participants in the construction process: designers, engineers, managers, and contractors. The large number of entities involved in the provision of data to the model, must be based on common standards of design. This allows combine partial models developed by specialists of specific industries in a global model. The condition is compatibility model files to each other. It is important a common format for data storage, which allows the same interpretation of the models supplied by the various participants of a construction project. IFC is the basic standard for the recording format. Its used in the modeling project using BIM methods.

Building Information Modeling in geotechnical projects

Building Information Modeling is a record model in the form of elements in combination, represented in a parametric way of a specific identification number (ID). This allows explicit assignment of the properties the geometric elements, strength parameters, or material (TOMALA 2016).

In the cycle of collecting and transmitting data to the global database BIM model, data from the geotechnical industry are made available to the planning

stage. These include geotechnical data layers of soil, the soil strength parameters: the angle of interior friction and cohesion. Geometric data related to course of geotechnical layers, developed on the basis of profiles of the research and prepared geotechnical sections. Application of BIM enables the acquisition of terrain data to project. It is obtained terrestrial laser scanning. Comprehensive data on the terrain shape and the course of geotechnical layers, are used to calculate the behavior of a building in the next stages of its implementation (ZHANG et al 2016). BIM data collection does not end at the design stage, but also includes, for example, data obtained from construction site. This allows update the assumptions made at the design stage.

In current practice of engineering, geotechnical project had closed source data. Modeling of the object using the assumptions of the BIM method enables connection geotechnical data and their use over the lifecycle of a building. The use of geotechnical data as part of the project BIM reduces the risk of the project, in the form of unexpected costs or extend the investment execution. Geotechnical data in the concept of BIM are not a new issue. In 1989 AGS (Association of Geotechnical and Geoenvironmental Specialists) created a data format for processing and use in other industries construction. Despite the many advantages implemented standard has not been widely used. The fundamental drawback was the inability to interpretation of the data, in the form of eg. surface course of geotechnical layers (MORIN et al. 2014). BIM solves problem with the interpretation of spatial geotechnical data. Adjustment of spatial geological models for use in the construction industry creates huge opportunities to take into account the behavior of complex object. Currently, the practice of engineering is based on the assumption that the layout of geotechnical layers is uniform along length and is not substantially changed. Hence, most of the analysis is based on the assumption of plane strain and stress state of geotechnical models. Application of BIM method in geotechnical design is necessary. Research conducted by HM Government (KESSLER et al. 2015) have shown that the construction sector, in 2025 will be dominated by the new approach BIM in 70%. In addition, in the UK since 2016 all investments in the system of public procurement (Industrial Strategy 2012), have to be aligned with existing standards BIM. Implementing BIM in the construction industry has the largest share in the US. Projects executed in this method, account for over 70% of the total number of ongoing contracts (Value of BIM in North America 2012). In Europe, the largest share of use BIM in the design focuses on three countries: Germany, France and UK. It represents a total of approximately 35% of all projects (KIVINIEMI 2010). The legal status of BIM adapting in the world is as follows (DI GIACOMO 2015):

a) Great Britain – required BIM technology in government projects. Projects implemented at BIM represent 39% of all;

- b) Norway, Finland – Introduced regulations that allow BIM design;
- c) Central and Southern European countries 14% of BIM projects, 60% of designers do not use this technology to design;
- d) China – 5% implementation of BIM, a big upward trend;
- e) Japan – almost 5% of BIM use in construction, 80% of participants in the construction process are aware of the use of this technology;
- f) Austria – strong BIM adoption;
- g) Singapore – 50% use BIM in construction;
- h) US – largest share of the discussed technology. Special legal regulations: BIM standards, GSA & US Army BIM mandates.

In Polish conditions use of BIM method is not widely used. There are no legal solutions or standards precisely specifying the framework and extent of BIM method used in the construction industry (*Building Information Modeling. BIM in Poland* 2016).

The use of geoen지니어ing in BIM is usually taken into account in the form of a load of pressure coming from the geotechnical layers layout. Often objects are modeled on the ground elastic behaviour. This assumptions omitting plastic properties of ground. This causes multiple errors at the stage of project design. Research conducted in the UK (KESSLER et al. 2015) have shown that more than 70% of investments in the public procurement system have exceeded the budget. The reason was poor recognition of geotechnical layers property. The article focuses on showing the use of BIM design method in geotechnical engineering. The use of that method will be presented in the context of the impact of a tall building “Mogilska Tower” in Cracow on existing buildings located in the vicinity of the planned investment. Building model was developed using Midas nGEN software based on the concept of BIM. In order to evaluate the impact of an object on the neighboring buildings, used data of geotechnical parameters (e.g strength parameters or the course of geotechnical layers). In addition, used terrestrial laser scanner in order to reflect the actual terrain shape. The resulting data were used to generate a numerical model of the area. In model used the loads results obtained from a model based on the BIM. The results were used to evaluate the influence of high building on neighboring buildings as specified (KOTLICKI, WYSOKIŃSKI 2002).

Materials and methods

Numerical analysis of high building model was carried out in the CAE/CAD Midas nGEN. Parametric building model consisted of 15 storeys above ground and 3 underground storeys. The total height of the building is equal 45 m. The object was fixed at a depth of -10 m below ground level. The building was

realized in the frame construction, made of reinforced concrete load-bearing walls and partition walls from silicate blocks (PILECKA, SZWARKOWSKI 2017). Slabs, balconies, stairs were modeled as reinforced concrete elements. Figure 1 shows the visualization of the object (SEMACO INVESTMENT GROUP). The following assumptions for modeling tall building:

- the dimensions of the building plan: length: 51 m, width: 19.5 m;
- the dimensions of the underground building plan: length: 51 m, width: 19.5 m;
- the thickness of the monolithic elements, slabs and stairs: 15 cm;
- bearing walls of reinforced concrete with a thickness: 15 cm, 20 cm, 30 cm, 60 cm;
- thickness walls of silicate blocks: 10 cm and 15 cm.



Fig. 1. The concept of high building “Mogilska Tower” in Cracow

Source: www.semaco-ig.pl

Loads has been selected on the basis of standard (LENDUSZKO 2014). Adopted use loads for residential rooms, category A, equal to 2.0 kN m^{-2} for stairs 4.0 kN m^{-2} and balconies 2.0 kN/m^2 . Material parameter of construction components and filling selected in standards (LENDUSZKO 2014). To determine the characteristic snow load on the model used standard (PAWŁOSKI, CAŁA 2013). Assumed load value equal to 0.96 kN/m^2 . Detailed calculations of the load given in article (PIECKA, SZWARKOWSKI 2017). Figure 2 shows the pressure peaks of wind speed, together with the distribution of external pressure $c_{pe,10}$ for high building.

Structural factor determined on the based on the logarithmic formula (EN 1991-1-4 2008) and the algorithm calculations presented in the article (ŻURAWSKI, GACZEK 2010). For building was chosen category 4 of the urban area. Logarithmic decrement of damping was equal to $\delta = 0.10$ for analyzed object.

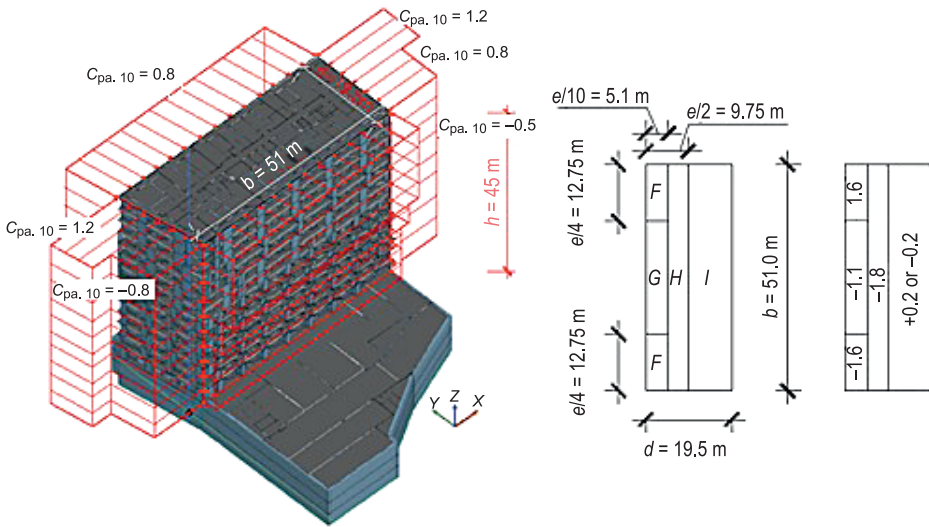

Fig. 2. Pressure peaks of wind speed, together with the distribution of external pressure $c_{pe,10}$
Source: PILECKA, SZWARKOWSKI (2017).

Eigenvalues determined in the article (PILECKA, SZWARKOWSKI 2017) were equal: for first the form of vibration $f_1 = 2.70 \text{ Hz}$, for the second form of vibration $f_2 = 3.01 \text{ Hz}$. Numerical model adopted on the level of detail LOD300 (TOMALA 2016). Numerical analysis was conducted based on flat finite elements. The mesh size was set equal to 0.5 m . Adopted unmovable boundary conditions at the base of the model. Numerical analysis was used to generate the reaction forces of the base model for next stages of raising the object. The individual values of the reaction forces used in the numerical model of the subgrade. It allowed to determine the impact of the implementation object to the existing buildings.

The spatial model of geotechnical layers of area in the vicinity of the planned building, made on the basis of geological engineering documentation (LENDUSZKO 2014). Linear change the course of geotechnical layers was adopted between the research profiles.

Subgrade of consider area is characterized by a complex geological structure. Anthropogenic soils occur below a depth of 1.6 m from ground level. Layer of gravel is from -1.6 m to -12 m below the ground level. Miocene clays are located at a depth of -13.3 m to -14.8 m . The numerical model of the subgrade takes into account the three layers of geotechnical. Table 1 shows the parameters of the layers included in the numerical model (SZWARKOWSKI 2017).

Geotechnical layers modeled elastic-plastic model of Mohr-Coulomb with linear plasticity condition. Area of land numerical model was generated based

Table 1

Geotechnical parameters of layers adopted in numerical modeling

Soil name	Φ [°]	c [kPa]	γ [kN/m ³]	E_0 [MPa]	ν [-]*	I_L/I_D
Ia1(saclSi)	13.00	13.50	20.50	16.50	0.25	0.30
IIa (MSa)	30.50	0.00	19.00	50.00	0.25	0.55
IIc (Gr saGr)	39.00	0.00	20.50	146.00	0.25	0.55
IIIa (Cl)	13.00	60.00	21.50	22.00	0.25	0.00

* information from CALA and FLISIAK (2000), GRIFFITHS and LANE (1999).

on the measurement of terrestrial laser scanning. Terrain model was created by combining triangular elements for point cloud. The cloud consists of several dozen millions of points obtained as a result of the measurement the laser beam. A detailed description of the research procedure using terrestrial laser scanning to generate the surface of the terrain for the numerical models are included in the article (SZWARKOWSKI, ZIĘBA 2017). A similar use of laser scanner in BIM was used in the modeling of a historic building in city Sondrio of Italy (BARAZZETTI et al. 2015).

Evaluation of the impact of high building “Mogilska Tower” in Cracow on existing buildings, in the context of the use BIM methods in geotechnical engineering, is based on the following stages of modeling:

- Stage I: Initial analysis model before executing the excavation. Linear static analysis;
- Stage II: Driving steel sheet piles to a depth of 16m below ground level to layer Miocene clays. Nonlinear static analysis;
- Stage III: Execution of a deep excavation to a depth of 10 m below ground level, along with the installed HP320 profiles. Nonlinear static analysis. Details in the article (SZWARKOWSKI 2017);
- Stage IV: Comparison of the results of vertical displacements obtained from numerical modeling of deep excavation with deformations obtained from measurements of terrestrial laser scanner and geodesic measurements (PILECKA, SZWARKOWSKI 2015);
- Stage V: Execution of underground storeys. Load implementation from the model of the building, to the level of the bottom of excavation. Nonlinear static analysis;
- Stage VI: The underground storeys backfilled with soil. Nonlinear static analysis;
- Stage VII: Execution of 6 floors above ground building. Nonlinear static analysis;
- Stage VIII: The loads from the self weight of the building model includes all 14 floors above ground. Nonlinear static analysis;
- Stage IX: Full load building model: loads: self weight, use load, weight of snow, wind pressure. Nonlinear static analysis;

– Stage X: Comparison of the results of vertical displacements in the vicinity of the existing building with the limit values set out in the specifications ITB (KOTLICKI, WYSOKIŃSKI 2002, PN-81/B-03020 1985).

Numerical model of the subgrade located in a deep excavation. It was modeled hexagonal finite elements of size 1 m. Subgrade close to excavation divided of finite elements mesh of size 2 m. Steel sheet, constituting the casing of excavation was modeled quadrangular finite elements of type shell. The size of shell elements is 1 m. Elements for the top beam and steel profiles matched the size of the finite elements of type beam equal to 1 m. Movements of the soil model is blocked at the horizontal direction, allowing freedom of displacement in the vertical direction. The basis of the model immobilized in three directions. Between elements of shell casing excavation and subgrade modeled contact, based on the Coulomb law (SZWARKOWSKI 2017). Results of vertical displacements, compared with the limit values for existing buildings situated in the vicinity of a deep excavation (KOTLICKI, WYSOKIŃSKI 2002). On the basis of the guidelines drawn up zone of direct influence of deep excavation on existing buildings and the zone of secondary impact, including the maximum range of influence of deep excavation. Figure 3 shows the range of impact zones of deep excavation on the existing building. Zone SI refers to the immediate effect of deep excavation on the existing development building and its range is 7 m. SII zone is associated with a secondary impact of the deep excavation and the proposed high building on the existing construction. Its range is not more than 20 m from the edge of the excavation.

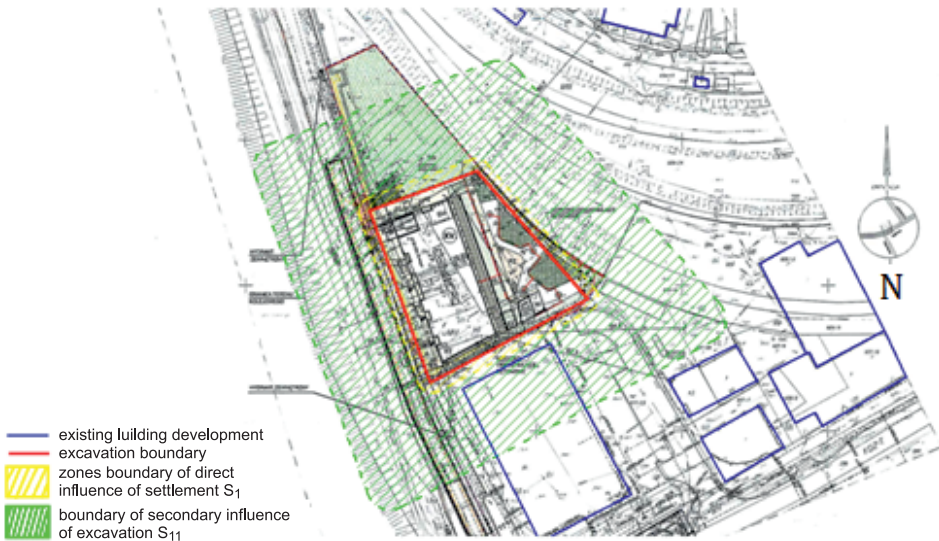

Fig. 3. The development plan with marked zones of influence of deep excavation
 Source: SZWARKOWSKI (2017).

Maximum allowable settlement for the existing building structure should not exceed 8 cm, according to norm PN-81/B-03020 (1985). Figure 4 shows the procedure for assessing the impact of a tall building on existing development.

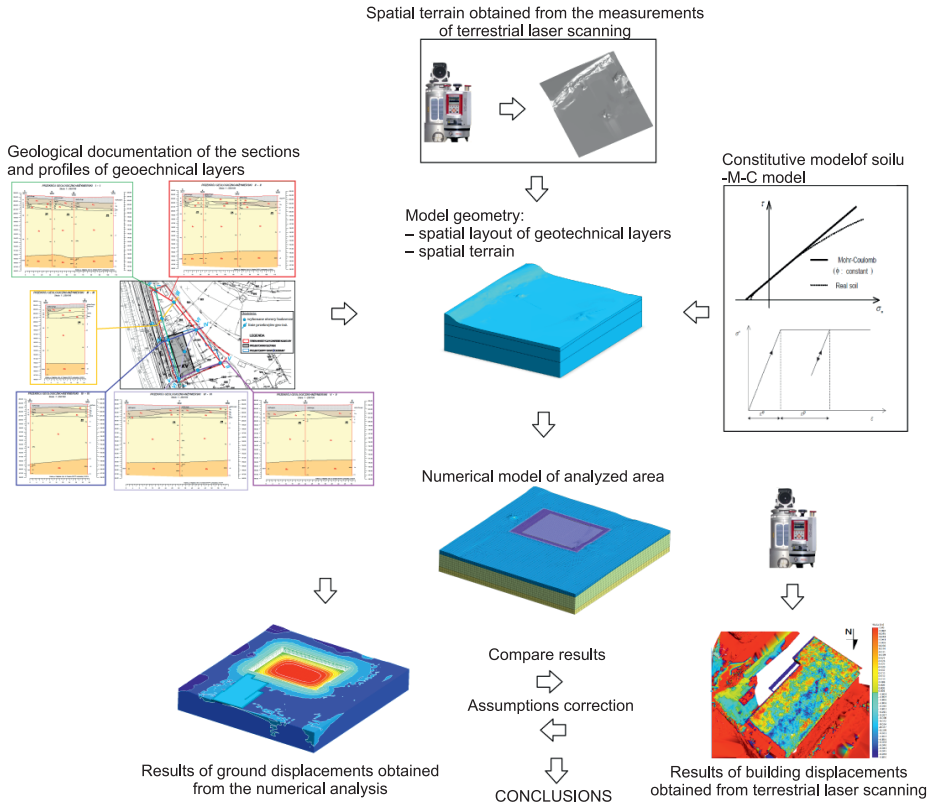

Fig. 4. Algorithm for determination of the impact the execution deep excavation on settlement neighboring building

Source: SZWARKOWSKI (2017).

Results and discussion

The impact of high building “Mogilska Tower” in Krakow was determined on the basis of numerical analysis of the subsoil, made of deep excavation in the neighbor of the existing buildings. The numerical model determined areas corresponding to the zone of direct impact of building settlements S_I , and to change the vertical displacements in the area S_{II} of secondary impact on building development. The analysis took into account total loads of building model in foundation level of excavation. Figure 5 and Figure 6 shows the

vertical displacements obtained in step IX with marked zones of influence of S_I and S_{II} . Displacements determined using the simplified method given in the specification ITB (KOTLIICKI, WYSOKIŃSKI 2002). Vertical displacements determined for 18 measuring points spaced every 4 m (Fig. 5).

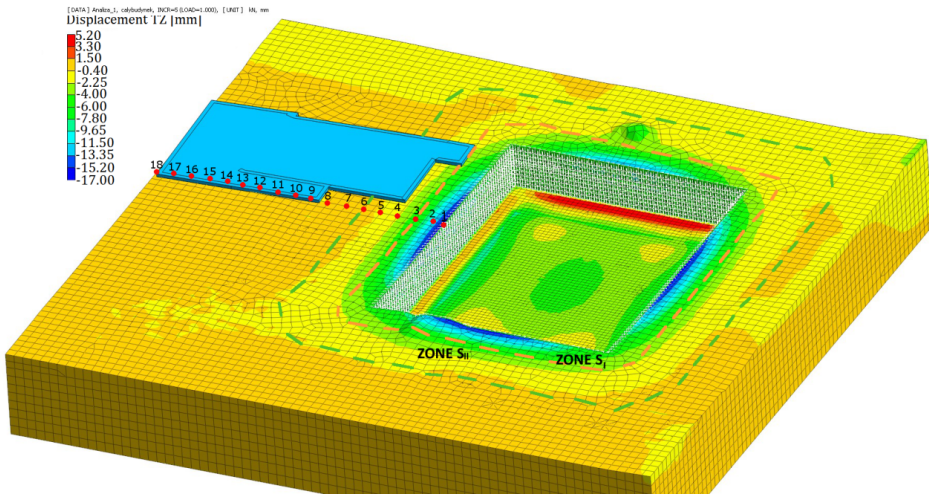

Fig. 5. Vertical displacements in the vicinity of the existing building for stage IX of numerical analysis
Source: SZWARKOWSKI (2017).

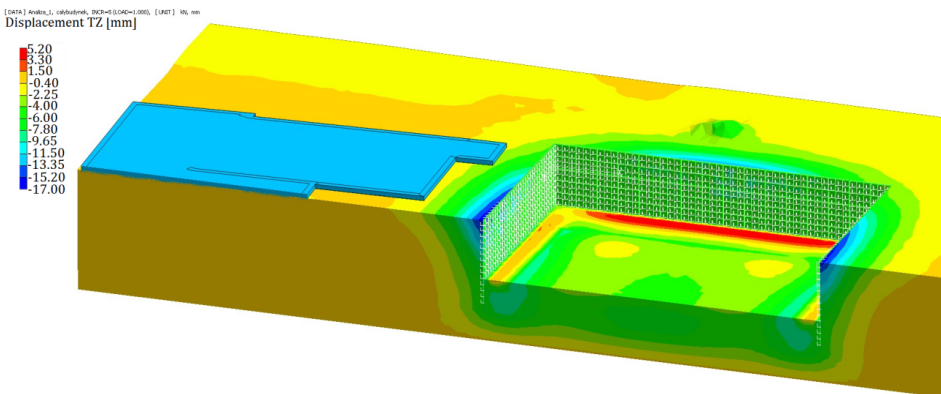

Fig. 6. Vertical displacements in the vicinity of the existing building in deep excavation section; stage IX numerical analysis

Source: SZWARKOWSKI (2017).

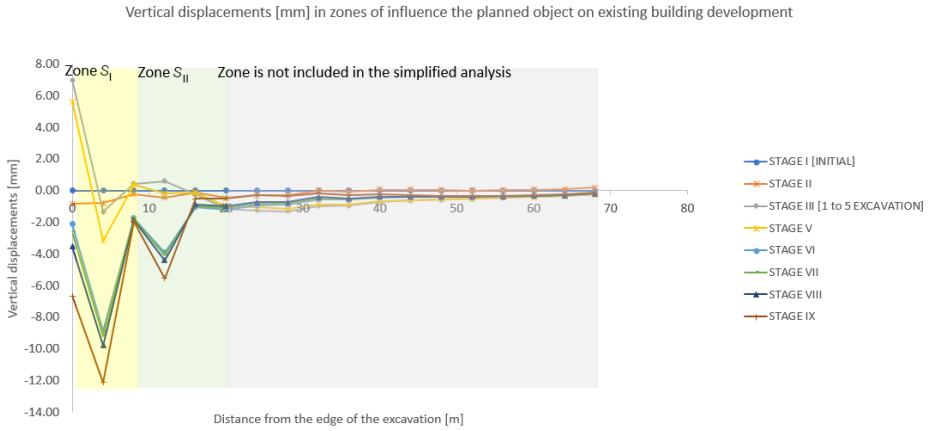

Fig. 7. Vertical displacements in zones of influence the planned object on existing building development

Source: SZWARKOWSKI (2017).

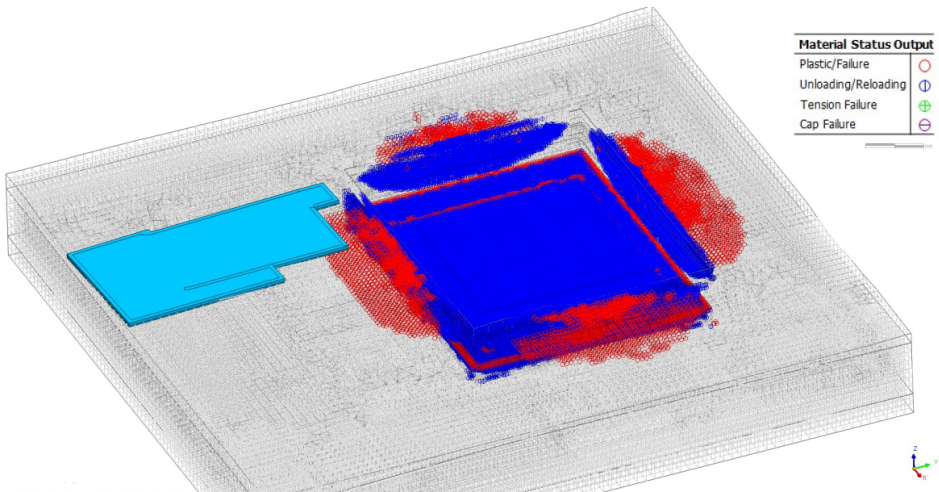

Fig. 8. Plasticity zones of ground in the vicinity of deep excavation

Source: SZWARKOWSKI (2017).

Displacement obtained for each affected zones of high building on neighboring buildings, for the last numerical analysis (stage IX), are equal: zone S_I direct impact of deep excavation for building $S_I = 12$ mm, zone S_{II} is equal to almost 6 mm. The largest displacements are located at distance no greater than 4 m from the edge of excavation. Beginning edge of the building is located 8 m from the edge excavation. It corresponds to the vertical displacements of the order of 4–6 mm. For the building portion, it located in the zone of vertical deformation S_{II} and not exceed 3 mm. The remaining part of the building is

sited on area where not required simplified analysis. The maximum displacement does not exceed 1 mm. Figure 8 shows a plastic deformation area of ground in the vicinity of deep excavation.

Figure 8 shows regions exceeding the maximum soil shear strength give rise the formation of zones plasticity of ground, according to Mohr-Coulomb model with linear plasticity condition. Maximum effects of the impact of the deep excavation loaded with forces of the planned building on existing building development shows in Figure 8.

Conslusions

The values obtained for the maximum deformation numerical model of the subgrade subjected to the influence of a deep excavation loaded high building, showed that the vertical displacements do not exceed the limit specified in the specification ITB and standard PN-81/B-03020. Displacement values do not exceed the limit values 8cm. The deep excavation with a planned investment in the form of a 15-storeys high building “Mogilska Tower” will not adversely affect the work of construction of the existing building. Measurement conducted using terrestrial laser scanning and geodesic measurements showed displacements of the building equal 3 mm. In article summarizes the results of soils deformation only due execution of deep excavation. The obtained data have been developed for the typical model of the soil based on the Mohr-Coulomb hypothesis with linear plasticity condition. The proximity of the location of the object with the existing buildings would require to carry out detailed numerical calculations, taking into account the full model the plastic behavior of ground, eg. using a model Cam-Clay for layers of Miocene clays. However, this requires additional, time-consuming laboratory tests using triaxial or oedometer apparatuses. This is related to a problem to increase spending on geotechnical researches and a better recognition of the subsoil. Obtained additional parameters can be used to model the soil, taking into account the full plasticity of the considered medium (eg. mentioned earlier Cam Clay model or Modified Mohr-Coulomb model). This is particularly important for modeling the behavior of plastic soils: clays, silts. As mentioned in the introduction of article, the better recognition and numerical analysis with the use of numerical modeling based on the method of BIM enables probably reduce the negative effects, which may occur during implementation of the investment. They can have an impact on the increase in investment costs. BIM technology in geotechnical engineering, use of complex data from field studies, laboratory and numerical modeling of the planned investments, allows more accurate way to predict the behavior of the planned investments and reduce costs.

References

- BARAZZETTI L., BANFI F., BRUMANA R., GUSMEROLI G., PREVITALI M., SCHIANTARELLI G. 2015. *Cloud-to-BIM-to-FEM: Structural simulation with accurate historic BIM from laser scans*. Simulation Modelling Practice and Theory, 57: 71–87.
- Value of BIM in North America. Multi-Year trend Analysis and User Rating. 2012. SmartMarket Report. McGraw-Hill Construction. Online: <http://www.bimformasonry.org/pdf/the-business-value-of-bim-in-north-america.pdf> (access:open source)
- CAŁA M., FLISIAK J. 2000. *Analiza stateczności skarp i zboczy w świetle obliczeń analitycznych i numerycznych*. XXIII Zimowa Szkoła Mechaniki Górotworu, Bukowina Tatrzańska.
- DI GIACOMO E. 2015. *BIM, trends from all around the world*. European BIM Summit, February 13th, Barcelona.
- EN 1991-1-4:2008. *Eurocode 1: Actions on structures-Part 1-4: General actions-Wind actions*.
- GRIFFITHS D.V., LANE P.A. 1999. *Slope stability analysis by finite elements*. Geotechnique, 49(3): 387-403.
- Industrial Strategy: government and industry in partnership. 2012. Building Information Modeling, HM Government, London.
- KIVINIEMI A. 2010. *Proprietary vs open BIM-demand public project*. SCRI BIM Forum, School of the Built Environment.
- KESSLER H., WOOD B., MORI G., GAKIS A., MCARDLE G., DABSON O., FITZGERALD R., DEARDEN R. 2015. *Building Information Modeling (BIM) – A Route for Geological Models to Have Real World Impact*. AER/AGS Special Report 101, p. 13-18.
- KOTLIICKI W., WYSOKIŃSKI L. 2002. *Ochrona zabudowy w sąsiedztwie głębokich wykopów*. Instrukcje, Wytyczne, Poradniki, 376, ITB, Warszawa.
- LENDUSZKO P. 2014. *Dokumentacja geologiczno-inżynierska dla projektowanej inwestycji: budowa budynku mieszkalnego wielorodzinnego z usługami w parterze wraz z infrastrukturą techniczną i garażem podziemnym oraz zagospodarowaniem terenu w zakresie kubatury zlokalizowanej na działce nr 657/31 obr. 4 Śródmieście w rejonie ul. Mogiłskiej w Krakowie*. Firma Usług Projektowych Paweł Lenduszek, Kraków.
- MORIN G., HASSALL S., CHANLER R. 2014. *Case study – The real life benefits of Geotechnical Information Modelling*. Information Technology in Geo-Engineering, Durham, p. 95–102.
- PAWŁOSKI A.Z., CAŁA I. 2013. *Budynki wysokie*. Oficyna Wydawnictwa Politechniki Warszawskiej, Warszawa.
- PILECKA E., SZWARKOWSKI D. 2015. *Wykorzystanie skanera laserowego RIEGL VZ-400 do badania deformacji na terenach górniczych GZW*. Budownictwo Górnicze i Tunelowe, 4.
- Building Information Modeling. Ekspertyza dotycząca możliwości wdrożenia metodyki BIM w Polsce. 2016. Polish Ministry of Infrastructure and Construction, KPMG Advisory sp. z o.o., sp.k., Warszawa.
- PN-81/B-03020. 1985. *Grunty budowlane. Posadowienie bezpośrednie budowli. Obliczenia statyczne i projektowanie*. ITB, Warszawa.
- SZWARKOWSKI D., ZIEBA J. 2016. *Monitoring osiadań budynków w sąsiedztwie głębokiego wykopu budynku „Mogiłska Tower” w Krakowie przy zastosowaniu naziemnego skaningu laserowego Riegl VZ-400*. Episteme, Kraków, p. 149–160.
- SZWARKOWSKI D. 2017. *Wpływ wykonania głębokiego wykopu pod budynek wysoki Mogiłska Tower w Krakowie na istniejącą zabudowę w ujęciu modelu przestrzennego opartego na metodzie elementów skończonych*. Współczesne budownictwo w badaniach młodych naukowców, Gdańsk.
- SZWARKOWSKI D., ZIEBA J. 2017. *Slope stability analysis of an open-pit mine as a prospective S-7 and S-52 road intersection*. Transaction 11/2017. Cracow.
- TOMALA A. 2016. *BIM. Innowacyjna technologia w budownictwie. Podstawy, standardy, narzędzia*. PWB MEDIA, Kraków.
- Semaco Invest Group. Mogiłska Tower. www.semaco-ig.pl/inwestycje/mogilska-tower/.
- ZHANG J., WU CH., WANG L., MAO X., WU Y. 2016. *The Work Flow and Operational Model for Geotechnical Investigation Based on BIM*. IEEE Access. Digital Object Identifier 10.1109/ACCESS.2016.2606158.
- ŻURAWSKI J.A., GACZEK M. 2010. *Obciążenie wiatrem budynków w ujęciu normy PN-EN 1991-1-4:2008*. Inżynieria i Budownictwo, 9: 494–501.