

Emergency Unberthing without Tug Assistance

Y. Kunieda, H. Yabuki, & T. Okazaki

Tokyo University of Marine Science and Technology, Tokyo, Japan

ABSTRACT: Shipmasters may have to perform unberthing without tugboat assistance when a tsunami warning is issued. Keeping this in mind, we studied emergency unberthing without tug assistance by conducting numerical simulations and full-mission ship maneuvering simulator (SMS) experiments. A panamax class medium-sized bulker and a pure car carrier (PCC) were used as test ships. In the experiments, we established the limitations of basic shiphandling techniques such as stern kick out, backing, and accelerating turn in windy conditions using a mathematical modeling group (MMG)-type mathematical maneuvering model. On the basis of the results, we produced a shiphandling scenario and evaluated it using SMS experiments. We concluded that unberthing without tug assistance in 5 m/s onshore winds is possible. Furthermore, the use of thrusters can greatly reduce the time required for unberthing.

1 INTRODUCTION

Many merchant ships moored at their berths were severely damaged by the tsunami that hit northeastern Japan following the March 11, 2011 earthquake.

In general, when a tsunami advisory or warning is issued, a shipmaster needs precise information to decide whether to take countermeasures with the ship moored or to take the ship out of the port and then evacuate it. If evacuation is decided, it is necessary to conduct unberthing without the assistance of tug-boats and line handlers.

We studied emergency unberthing without tug assistance using numerical simulations with a mathematical modeling group (MMG)-type mathematical model and conducted full-mission ship maneuvering simulator (SMS) experiments.

2 EXPERIMENTS

2.1 *Unberthing shiphandling without tug assistance*

The test ships were a panama-class medium-sized oceangoing merchant ship and a 6,000 unit pure car carrier (PCC). For mooring conditions, we assumed bow-in port-side mooring conditions because this mooring-type is common in most Japanese ports; however, unberthing from this mooring-type is difficult compared with that from stern-in mooring.

The unberthing of panamax class oceangoing merchant ships is typically performed with tug assistance; however, there are few reports on unberthing of the above ship-type that use only the ship's engine and rudder, or bow thruster. Therefore, we adopted the backing unberthing method from the bow-in port-side mooring, which is widely used by small merchant ships, in our experiments.

2.2 Experimental procedure

The experiments were conducted according to the procedure presented in Figure 1.

First, we specified the ship type and the berthing and mooring conditions. We then decided the shiphhandling procedure by considering shiphhandling water conditions such as fairway and turning basin. For the wind direction, we assumed onshore winds, which make shiphhandling difficult. Next, we estimated the limitations of basic shiphhandling, such as stern kick out, backing, accelerating turn from the sternway, and turning on the spot, using the MMG-type mathematical maneuvering model.

On the basis of the results, we produced a shiphhandling plan (scenario) and evaluated it using SMS experiments.

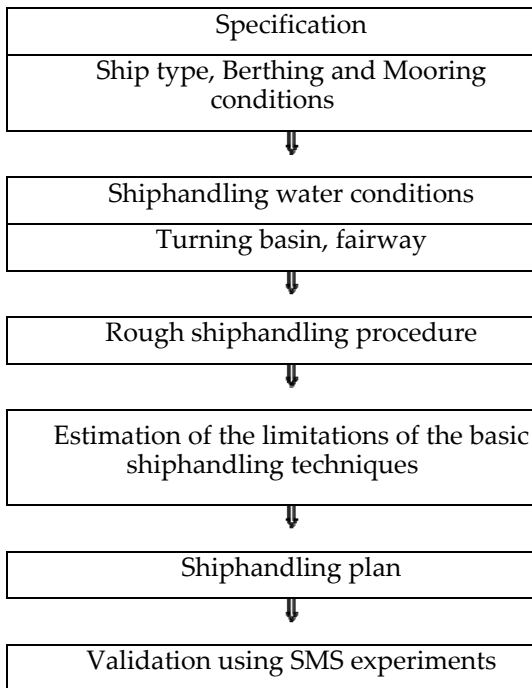

Figure 1. Experimental procedure

2.3 Ship motion model

We simulated the ship maneuvering motion using an MMG-type mathematical model (Kijima 1990). The coordinate system is shown in Figure 2. The state values were the ship's position, heading, surge speed, sway speed, and yaw rate. The control values were rudder angle order, propeller revolution order, and thrust order of the side thruster.

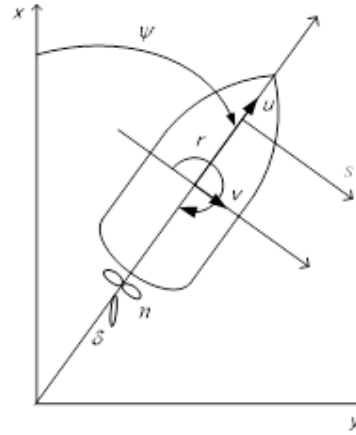

Figure 2. Coordinate system

The equations for surge, sway, and yaw motion are,

$$(m + m_x)\dot{u} - (m + m_y)vr = X_H + X_P + X_R + X_W \quad (1)$$

$$(m + m_y)\dot{v} + (m + m_x)ur = Y_H + Y_R + Y_S + Y_W \quad (2)$$

$$(I_{zz} + J_{zz})\dot{r} = N_H + N_R + N_S + N_W \quad (3)$$

where m is the mass, m_x and m_y are the added mass, I_{zz} is the turning moment inertia, and J_{zz} is the added moment of inertia. X and Y represent the hydro-dynamic forces and N represents the moment. Subscripts H , P , R , S and W denote the hydrodynamic force induced by the hull, propeller, rudder, side thruster and wind respectively.

We predict each of the hydrodynamic forces using the following methods.

- Added mass, moment of inertia: Motora's chart (Motora 1959)
- Hull: Kijima's method (Kijima 1990), Hirano's method (Hirano 1981)
- Propeller: Yoshimura's method (Yoshimura 1995)
- Rudder: Yoshimura's method (Yoshimura 1978)
- Bow thruster: Fujino's method (Fujino 1978)
- Wind: Yamano's method (Yamano 1997)

3 RESULTS

3.1 Panamax bulker

3.1.1 Test ship features and shiphhandling circumstances

Table 1 lists the principal characteristics of the 54,000 DWT Panamax bulker.

We assumed that the ship is moored bow-in port-side to berth A at the K Port in Tokyo Bay. In the experiments, starboard onshore winds without tide effects were assumed.

Table 1. Principal features (bulker)

Hull	
G.T. (ton)	43,000
LOA (m)	209.00
Lpp (m)	204.00
B (m)	32.20
Cb	0.8
Draft (fore m)	9.50
Draft (aft m)	10.50
Trim (m)	1.0 B/S
Displacement (ton)	52,931
Sail area (transverse m ²)	730
Sail area (vertical m ²)	4490
Main engine	
MCO (kW)	9,700
Rudder	
Height (m)	8.100
Breadth (m)	4.600
Area (m ²)	37.260
Aspect Ratio	1.7609
Propeller	
Blade	4
Dia. (Dp m)	5.600
Pitch ratio at 0.7R	0.702

3.1.2 Shiphandling procedure and limitations

1 Shiphandling procedure and techniques

The following undocking procedure was conducted.

- 1 After heaving on the starboard-side headline, all shore lines except the head line and forward spring were let go.
- 2 The stern to starboard was kicked out by at least two points by heaving on the head line while holding the spring and kicking the engine ahead with the rudder hard to port.
- 3 The ship was backed 1L (L; Lpp) off the berth with the engine dead slow or slow astern and the rudder hard to starboard. The sternway was maintained at approximately 2 knots for backing.
- 4 An accelerating turn or turning on the spot was made to keep the ship's position at approximately 1L from the berth and the ship then proceeded toward the port entrance by accelerating immediately.

Prior to the SMS experiment, it is necessary to examine the limitations of shiphandling techniques such as stern kick out, backing, accelerating turn from the sternway, and turning on the spot.

2 Shiphandling limitations

We estimated the limitations of each shiphandling technique when the test ship is affected by 5, 8, and 10 m/s onshore winds using the mathematical maneuvering model.

1 Stern kick out

Figure 3 presents the stern kick out angle for each wind velocity as a function of time. A positive value of the angle implies a right turn. The test ship required 3 min for 2 points kick out even in calm conditions and more time for the kick out maneuver under windy conditions. The calculation results suggest that, although the stern kick out seems to be possible even in the 10 m/s onshore wind,

substantial amount of time will be needed for this maneuver.

2 Backing from the berth

Figure 4 presents the estimated trajectories when the test ship backs with the engine dead slow astern and the rudder hard to starboard after the stern kick out maneuver. In Figure 4, the units in the X- and Y-axis are Lpp. In 5 m/s onshore winds, it was possible to back as assumed. However, as winds increased to 8 m/s, the test ship drifted leeward at the early stage of backing when the sternway was slow.

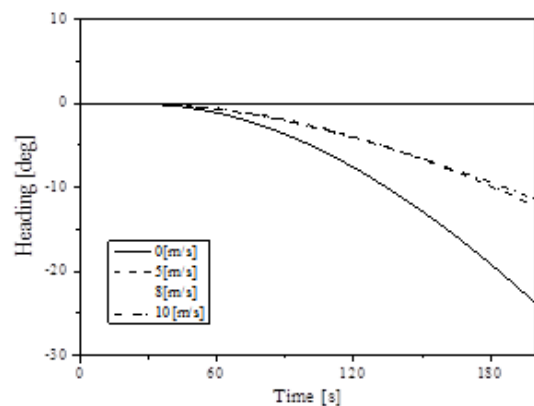

Figure 3. Time relation of the stern kick out angle (Bulker)

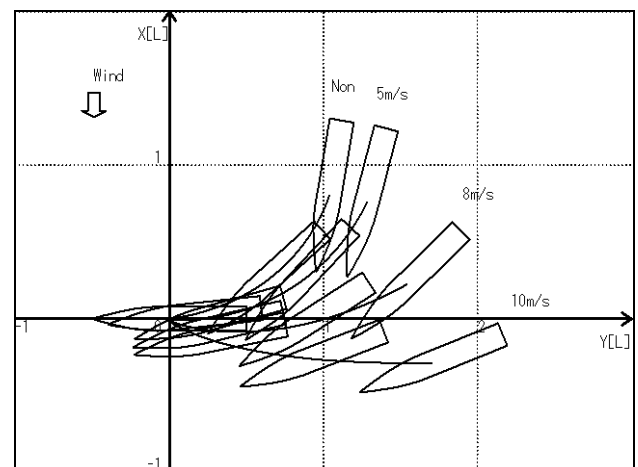

Figure 4. Bulker's trajectories of backing with the rudder hard to starboard

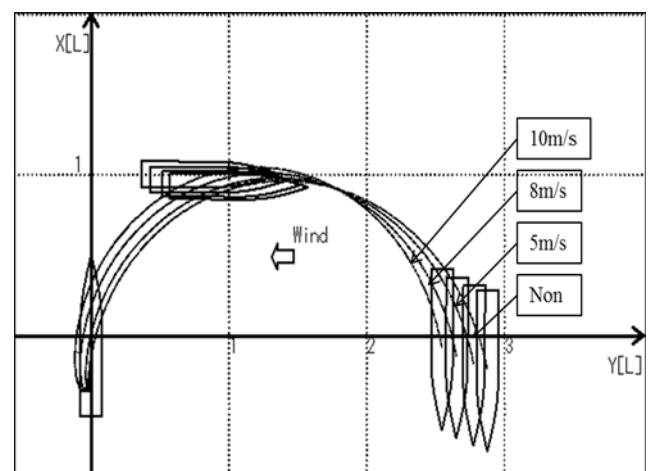

Figure 5. Bulker's trajectories for accelerating turn

Therefore, backing by the engine astern and the rudder hard to starboard is difficult with 8 m/s onshore wind. In addition, the leeward drift increases when the sternway turn is slow.

1 Accelerating turn

Figure 5 presents the trajectories when the test ship accelerated windward to leeward. It seems that the turning maneuver is possible with 10 m/s winds. During the leeward turning maneuver, the stronger the wind force is, the greater the drift becomes after turning 90°. Thus, it is necessary to make this turning maneuver in the direction of the wind.

2 Turning on the spot

We examined the turning-on-the-spot maneuver under windy conditions using the shiphandling simulator. Figure 6 presents the trajectory when the test ship made the abovementioned sternway maneuver at 2 knots in 8 m/s winds. As the turning circle diameter is 1.8L and the turning time is 18 min, we infer that the turning maneuver can be performed in 8 m/s winds.

3.1.3 Results of the SMS experiments

Figure 7 presents the ship trajectory under calm conditions. Both the trajectories of the center of gravity and the ship's shape at 3 min intervals are displayed. The units of the X- and Y-axis are Lpp. Figure 8 presents the time relation of the engine operation and speed. In this case, although a shiphandling procedure same as that described in 3.1.2 was conducted, the whole procedure took 27 min, probably, because of the left turning-on-the-spot and the low-power operation of the main engine.

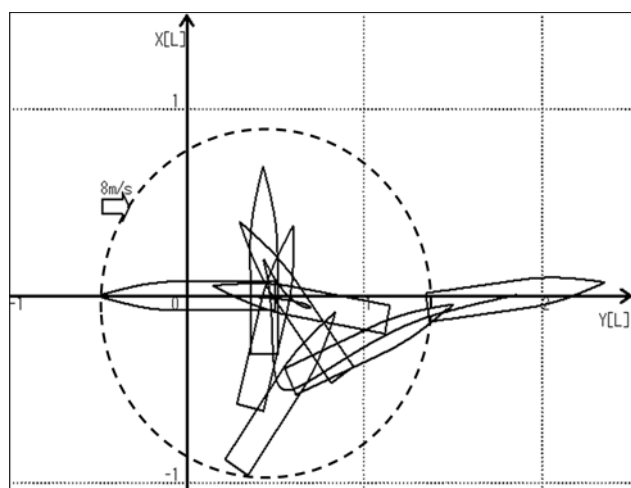

Figure 6. Bulker's trajectories of turning on the spot

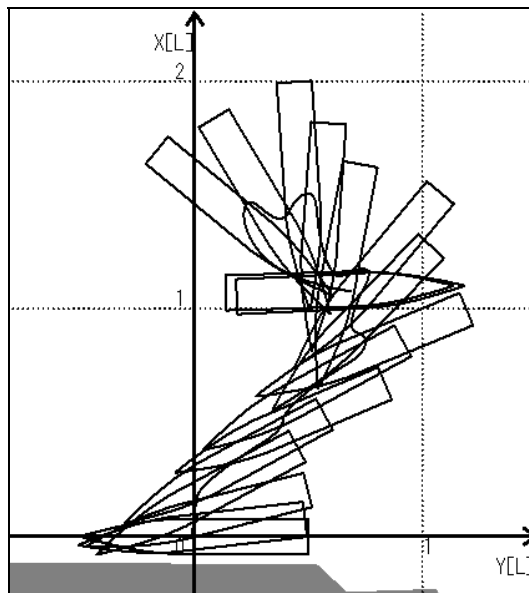

Figure 7. Trajectory of the unberthing bulker in calm conditions

The ship's trajectory and time relation of the engine operation and speed in 5 m/s onshore winds are presented in Figures 9 and 10, respectively. In this case, the stern kick out maneuver was completed within almost the same time as that in calm conditions by applying rather strong ahead engine motion.

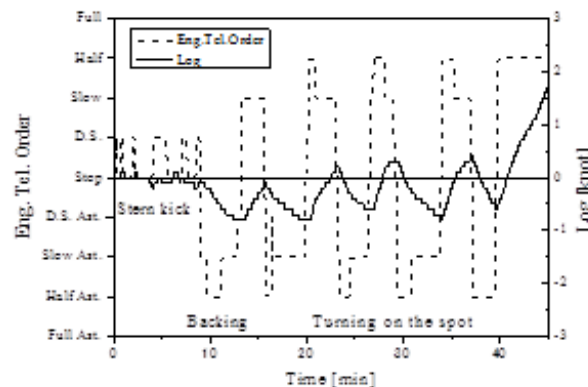

Figure 8. Time history of engine operation and speed in calm conditions

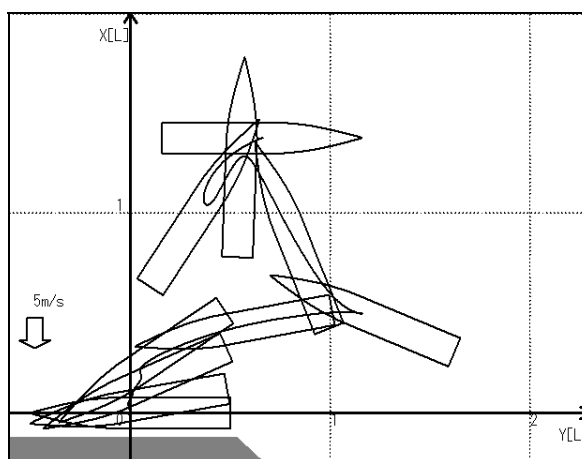

Figure 9. Trajectory of the unberthing bulker in 5 m/s onshore wind

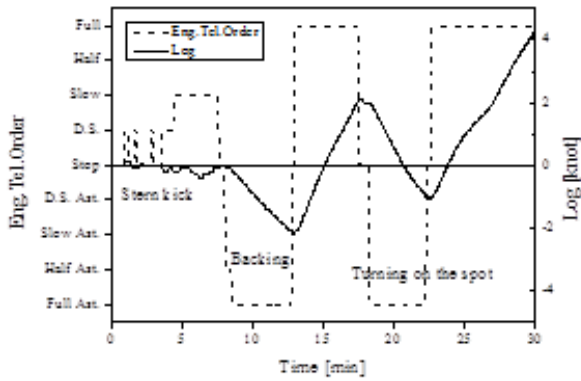

Figure 10. Time history of engine operation and speed in 5m/s onshore winds

The ship completed the turning on the spot in the direction of the wind in approximately 15 min using rather strong engine operations, and the total maneuvering time was approximately 27 min. Although the test ship drifted leeward during backing, the ship was able to proceed windward with the full ahead engine.

3.1.4 Evaluation of the shiphandling method

From the results obtained by establishing the shiphandling limitations and SMS experiments, we consider that this ship-type can unberth within a relatively short time without tug assistance in 5 m/s onshore winds.

When unberthing, it is necessary to mind the following.

- 1 During the stern kick out maneuver, do not slacken both the head line and forward spring, and do not apply excessive tension to the spring by properly operating the main engine. A substantial amount of time will be needed for the stern kick out maneuver when the beam wind blows to the berth.
- 2 During the backing maneuver, back the ship as soon as possible using rather strong astern engine motions. It is recommended to keep the ship sternway within 2 knots. Note that the response of the bulker to the engine operation is relatively slow during accelerating or decelerating.
- 3 Turning on the spot should be in the direction of the wind and the ship's head should be turned as soon as possible using rather strong astern engine motion. It is recommended to keep both headway and sternway at a maximum of 2 knots. When a ship drifts leeward during the turning maneuver, it quickly proceeds windward using the ahead engine and the rudder.

3.2 6,000 unit PCC

3.2.1 Test ship characteristics and shiphandling circumstances

Table 2 lists the characteristics of the 6,000 unit PCC with a bow thruster.

Table 2. PCC characteristics

Hull	
G.T. (ton)	57,623
LOA (m)	198.00
Lpp (m)	190.00
B (m)	32.26
Cb	0.57637
Draft (fore m)	8.50
Draft (aft m)	8.50
Trim (m)	Nil
Displacement (ton)	30,029
Sail area (transverse m ²)	1,224.26
Sail area (vertical m ²)	4,554.69
Main engine	
MCO (kW)	13,500
Rudder	
Height (m)	8.050
Breadth (m)	4.900
Area (m ²)	39.445
Aspect ratio	1.6429
Propeller	
Blade	5
Dia. (Dp m)	6.500
Pitch ratio at 0.7R	0.925
Bow thruster	
Thrust (ton)	17.8

We assumed that the ship is moored bow-in starboard side to berth O at Y Port in Tokyo Bay. In the experiments, port onshore winds without tide effects were assumed. We examined the effect of the bow thruster on unberthing maneuvers by comparing the handling of a ship with a thruster and that without a thruster.

3.2.2 Shiphandling procedure and limitations

1 Shiphandling procedure and basic shiphandling techniques

We followed the following unberthing procedure.

- 1 After preparing heaving on the port-side head line, all shore lines except the head line and the forward spring were let go.
- 2 The stern to port was kicked out by at least two points by heaving on the head line while holding the spring; the engine was kicked ahead with the rudder hard to starboard. A ship with a bow thruster uses it to starboard to hold her bow at a fixed position by pressing the ship's starboard bow against the fender.
- 3 The ship was backed 1L (L; Lpp) off the berth with the engine dead slow or slow astern and the rudder hard to port. The sternway was maintained at approximately 2 knots during backing.
- 4 As there was sufficient space for turning on the port-side of the ship, the ship completed an accelerating turn, keeping her position approximately 1L off from the berth, and proceeding toward the port entrance. The ship with a bow thruster can use it for assistance during an accelerating turn. In this case, it is necessary to examine the limitations of the following maneuver prior to SMS experiment: stern kick out, backing, and accelerating turn from the sternway.

2 Shiphandling limitations

We estimated the shiphandling limitations for each basic shiphandling technique when the test ship experiences 5, 8, and 10 m/s onshore winds using the mathematical maneuvering model. We performed the simulation calculations without a bow thruster.

3 Stern kick out

Figure 11 presents the time relation of the stern kick out angle for each wind velocity. As the time required for stern kick out was approximately 2 min in calm conditions and 3 min in 10 m/s port onshore wind, we considered that the stern kick out of PCC was easier than that of a bulker. Therefore, the stern kick out in relatively strong onshore winds was feasible with PCC, because a PCC can produce strong kick ahead power with the propeller as it was equipped with a stronger engine and a propeller larger than a bulker. In addition, the PCC's right-hand turning moment, which assists the ship's right turning, was generated by the left beam wind, as shown in Figure 12.

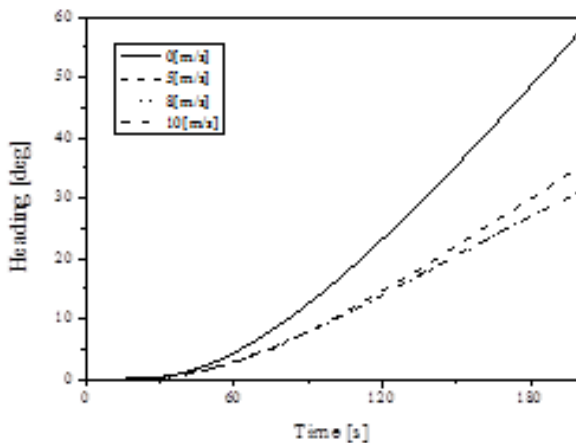

Figure 11. Time relation of the stern kick out angle (PCC)

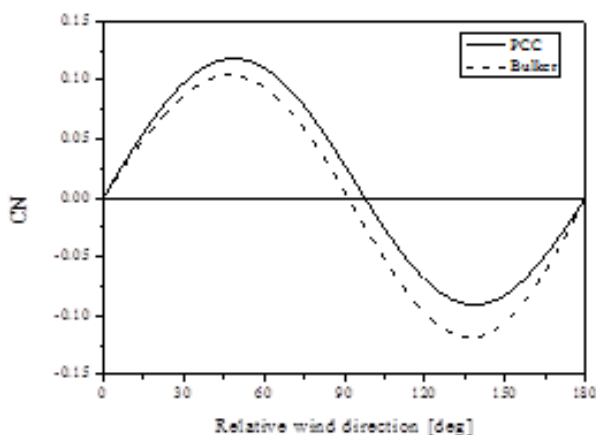

Figure 12. Coefficient of the yawing moment caused by wind

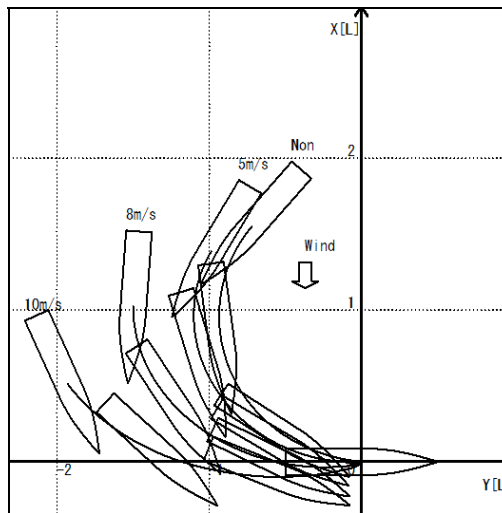

Figure 13. PCC trajectories of backing with the rudder hard port

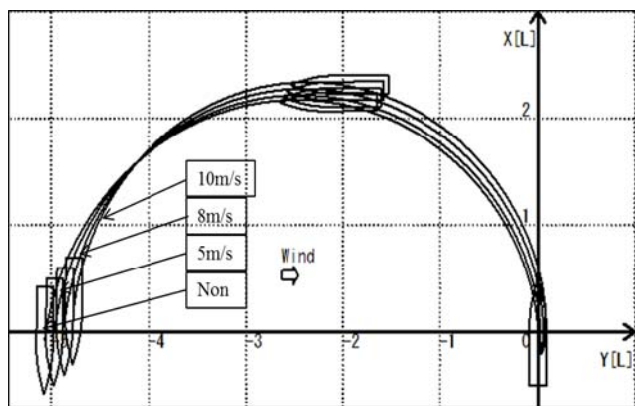

Figure 14. PCC trajectories during the accelerating turn

1 Backing from the berth

Figure 13 presents the estimated trajectories when the test ship backs with engine dead slow astern and the rudder hard to starboard after the stern kick out maneuver; the units of the X- and Y-axis are Lpp. It is possible to back with 5 m/s onshore winds; nonetheless, when the wind increases to 8 m/s, the test ship drifts leeward at the early stage of backing for slow sternway. In the case of 10 m/s left beam wind, the test ship strongly drifts leeward and backing seems difficult using only the engine and rudder.

2 Accelerating turn

Figure 14 presents the trajectories when the test ship made an accelerating turn windward at 2 knots of the sternway. A PCC can make an accelerating turn in 10 m/s winds, but it is necessary to conduct this maneuver in the direction of the wind.

3.2.3 Results of SMS experiments

Figure 15 presents the ship trajectory and Figure 16 presents the engine operation and speed in the experiment vs time under calm conditions. In this case, the left accelerating turn is in the direction of the berth because there is no wind effect on the hull. The trajectory of the test ship is similar to the predictions in 3.2.2, and the ship completes the unberthing maneuver as planned. In general, the headway of PCCs is strong even if the engine is dead

slow ahead; therefore, it is necessary not to excessively strain the spring during the stern kick out maneuver by properly operating the engine astern, as shown in Figure 16.

Figure 17 shows the ship's trajectory in the experiment using only the engine and rudder in 5 m/s on-shore winds. The test ship completed the unberthing maneuver in approximately 27 min according to the scenario, and the total maneuvering time was 3 min longer than that of the experiment under calm conditions. This is attributed to the longer time required to complete the stern kick out and accelerating turn maneuver when the beam wind is blowing in the direction of the berth.

Figure 18 presents the ship's trajectory and Figure 19 presents the time relation of the bow thruster operation and heading in the experiment using the PCC with a bow thruster under 5 m/s onshore winds. In this case, the total maneuvering time was 21 min. Using the bow thruster for the stern kick out and heading control during backing and the accelerating turn, the test ship unberthed in a relatively short time compared with that without a thruster. Figure 20 presents the same unberthing maneuver in 8 m/s onshore winds. Even through the onshore wind is relatively strong, the ship completed unberthing within 22 min. From the above results, we infer that the use of a bow thruster for unberthing under windy conditions is very effective.

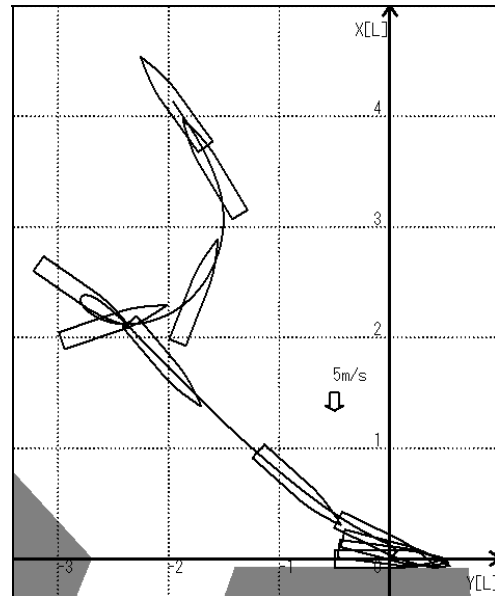

Figure 17. Trajectory of unberthing PCC in 5 m/s onshore wind

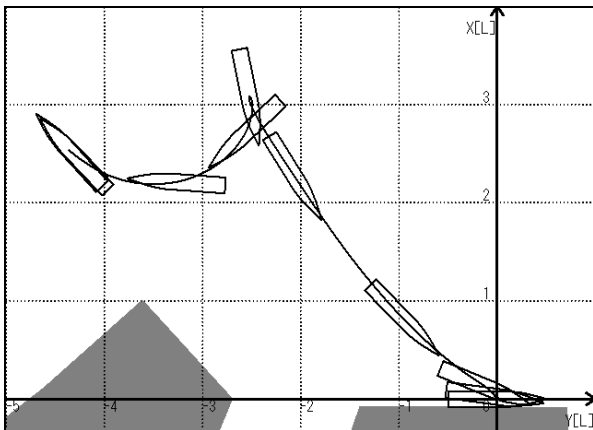

Figure 15. PCC trajectory of unberthing in calm conditions

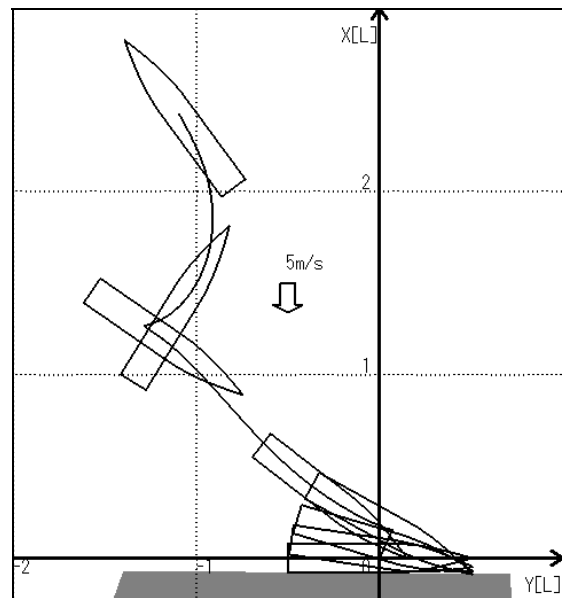

Figure 19. Trajectory of the unberthing PCC using the bow thruster in 5 m/s onshore winds

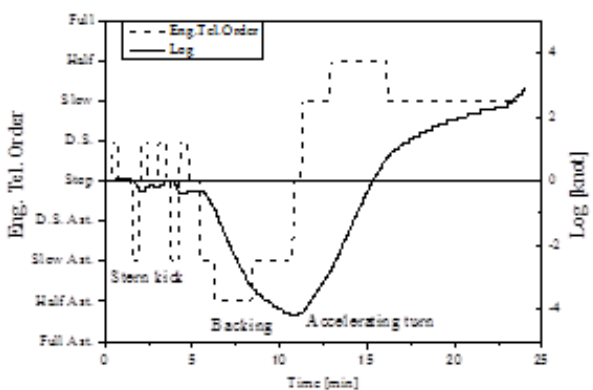

Figure 16. Time history of engine operation and speed in calm conditions

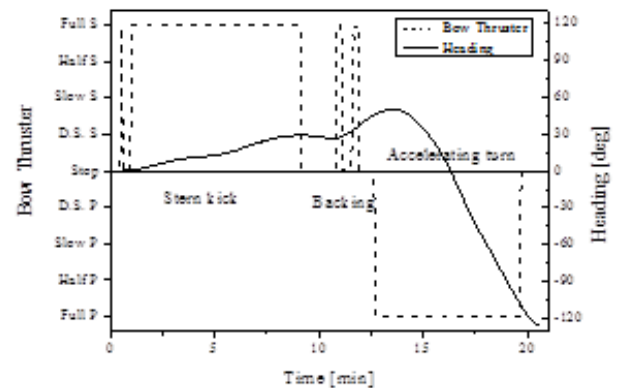

Figure 19. Bow thruster operation and heading vs time in 5m/s onshore winds

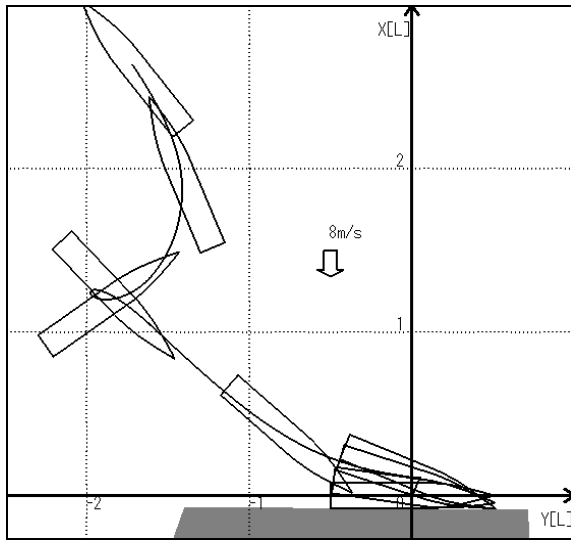

Figure 20. Trajectory of the unberthing PCC using the bow thruster in 8 m/s onshore winds

3.2.4 Evaluation of shiphandling method

From the shiphandling limitations and SMS experiments, we infer that ships of this type can complete unberthing within a relatively short time without tug assistance in 5 m/s onshore winds. When the ship uses a bow thruster, unberthing without tug assistance is possible in relatively shorter time in 8 m/s onshore winds.

It is necessary to consider the following during unberthing maneuvers.

- 1 During the stern kick out maneuver, as the engine output of PCC is relatively strong, the astern propulsion should be appropriately used so that excessive tension will not be applied to the forward spring. As for ships with a bow thruster, we recommend that the bows should be pressed against the fender using a thruster.
- 2 During backing under windy conditions, heading control using a bow thruster is effective.
- 3 Wind strongly affects this ship-type; thus, backing, accelerating turn, and turning on the spot will have to be performed at slow speeds. Therefore, it is necessary to mind the drift during the abovementioned maneuvers.

4 SUMMARY

We studied emergency unberthing without tug assistance using numerical simulations and SMS experiments for emergency evacuation outside the harbor because of a tsunami advisory or warning. We obtained the following results.

- 1 The backing unberthing method from the bow-in portside mooring commonly conducted by small merchant ships can be used to unberth panamax class oceangoing merchant ships without tug assistance.
- 2 It is possible to unberth using the ship's engine and rudder in the abovementioned maneuver in 5 m/s on-shore winds.
- 3 Ships can control their heading during backing and easily turn using a bow thruster, thus reducing the time required for shiphandling in windy conditions. Unberthing of ships with a bow thruster without tug assistance may be possible in 8 m/s onshore winds.
- 4 During the stern kick out maneuver, it is important not to slacken both the head line and the forward spring. In addition, no excessive tension must be applied to the spring by properly controlling the ship's headway using stop or astern propulsion.

REFERENCES

- Kijima, K., Katsuno, T., Nakiri, Y., & Furukawa, Y. 1990. On the manoeuvring performance of a ship with the parameter of loading condition, *Journal of the Society of Naval Architects of Japan*, 168, 141-148.
- Motora, S. 1959. On the Measurement of Add Mass and Added Moment of Inertia for Ship Motions Part 3, *Journal of the Society of Naval Architects of Japan*, 106, 63-68.
- Hirano, M., Takai, T., & Matsumoto, N. 1981. Application of maneuvering model to shipbuilding design, The 3rd Marine Dynamics Symposium Text, *The Society of Naval Architects of Japan*, 101-136.
- Yoshimura, Y., Ishigro, T., & Tanaka, S. 1995. Prediction of Full-scale Maneuverability in Early Design Stage, The 3rd Marine Dynamics Symposium Text, *The Society of Naval Architects of Japan*, 91-133.
- Yoshimura, Y. & Nomoto, K. 1978. Modeling of Maneuvering Behavior of Ships with a Propeller Idling, Boosting and Reversing, *Journal of the Society of Naval Architects of Japan*, 144, 57-69.
- Fujino, M., Sasuta, T., & Ida, T. 1978, Experimental Studies on the Effectiveness of the Side Thruster, *Journal of the Kansai Society of Naval Architects, Japan*, 168, 35-44.
- Yamano, T. & Saito, Y. 1997. An Estimation Method of Wind Force Acting on Ships, *Journal of Kansai Society of Naval Architects, Japan*, 228, 91-100.