

Zeroing of state variables in fractional descriptor electrical circuits by state-feedbacks

TADEUSZ KACZOREK

*Faculty of Electrical Engineering, Białystok University of Technology
Wiejska 45D, 15-351 Białystok
e-mail: kaczonek@isep.pw.edu.pl*

(Received: 24.09.2013, revised: 17.12.2013)

Abstract: The problem of zeroing of the state variables in fractional descriptor electrical circuits by state-feedbacks is formulated and solved. Necessary and sufficient conditions for the existence of gain matrices such that the state variables of closed-loop systems are zero for time greater zero are established. The procedure of choice of the gain matrices is demonstrated on simple descriptor electrical circuits with regular pencils.

Key words: fractional, descriptor, linear, electrical circuit, state-feedbacks, zeroing

1. Introduction

Descriptor linear systems with regular pencils have been considered in many papers and books [1-5, 7-9, 24, 39]. The eigenvalues and invariants assignment by state and output feedbacks have been investigated in [6-7, 23] and the realization problem for singular positive continuous-time systems with delays in [11]. The computation of Kronecker's canonical form of a singular pencil has been analyzed in [39]. Luenberger in [24] has proposed the shuffle algorithm to analysis of the singular linear systems. A method for the checking of positivity of descriptor linear systems by the use of the shuffle algorithm has been proposed in [13]. The positivity and reachability of fractional electrical circuits have been addressed in [10, 14] and descriptor (singular) fractional linear systems and electrical circuits in [17]. Modified version of the shuffle algorithm has been proposed for the reduction of the singular fractional system into dynamic and static parts in [15]. The descriptor fractional discrete-time linear systems have been investigated in [16].

The mathematical fundamentals of fractional calculus are given in the monographs [25-28, 32-35]. The fractional order controllers have been developed in [32, 33]. Theory of fractional discrete-time linear systems has been addressed in [28]. A generalization of the Kalman filter for fractional order systems has been proposed in [36]. Reachability and controllability to zero of positive and cone fractional linear systems have been considered in [12, 18, 20]. Some other applications of the fractional calculus can be found in [29-31, 37, 38].

The zeroing of the state variables in descriptor electrical circuits by state feedbacks has been formulated and solved in [21].

In this paper the problem of zeroing of the state variables in fractional descriptor electrical circuits by state-feedbacks will be formulated and solved. The paper is organized as follows. In Section 2 the fractional descriptor linear electrical circuits are presented. The zeroing problem is formulated and solved in section 3 where the necessary and sufficient conditions for the existence of solution to the problem are established. Concluding remarks are given in section 4.

The following notation will be used: \mathfrak{R} – the set of real numbers, $\mathfrak{R}^{n \times m}$ – the set of $n \times m$ real matrices, $\mathfrak{R}_+^{n \times m}$ – the set of $n \times m$ matrices with nonnegative entries and $\mathfrak{R}_+^n = \mathfrak{R}_+^{n \times 1}$, I_n – the $n \times n$ identity.

2. Descriptor linear electrical circuits

The following Caputo definition of the fractional derivative will be used [12, 27, 34]

$$D^\alpha f(t) = \frac{d^\alpha}{dt^\alpha} f(t) = \frac{1}{\Gamma(n-\alpha)} \int_0^t \frac{f^{(n)}(\tau)}{(t-\tau)^{\alpha+1-n}} d\tau, \quad n-1 < \alpha < n \in N = \{1, 2, \dots\}, \quad (2.1)$$

where $\alpha \in \mathfrak{R}$ is the order of fractional derivative and

$$f^{(n)}(\tau) = \frac{d^n f(\tau)}{d\tau^n} \quad \text{and} \quad \Gamma(x) = \int_0^\infty e^{-t} t^{x-1} dt$$

is the gamma function.

Consider the continuous-time fractional linear system described by the state Equation [12]

$$E \frac{d^\alpha x}{dt^\alpha} = Ax + Bu, \quad 0 < \alpha < 1, \quad (2.2)$$

where α is the fractional order, $x = x(t) \in \mathfrak{R}^n$, $u = u(t) \in \mathfrak{R}^m$ are the state and input vectors, respectively and $E, A \in \mathfrak{R}^{n \times n}$, $B \in \mathfrak{R}^{n \times m}$.

It is assumed that $\det E \neq 0$, $\text{rank} B = m$ and the pencil is regular, i.e.

$$\det [Es - A] \neq 0 \quad \text{for some } s \in C \quad (\text{the field of complex numbers}). \quad (2.3)$$

It is well-known [12, 17] that for example the electrical circuits with resistors, supercondensators and voltage sources can be described by the Equation (2.2).

Example 2.1. Consider the fractional electrical circuit shown on Figure 2.1 with given resistance R , capacitances C_1, C_2, C_3 and source voltages e_1 and e_2 .

Fig. 2.1. Electrical circuit of Example 2.1.

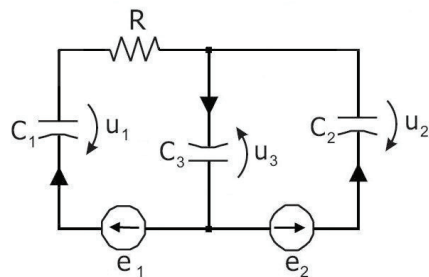

Using Kirchhoff's laws, for the electrical circuit we can write the equations

$$\begin{aligned}
 e_1 &= RC_1 \frac{d^\alpha u_1}{dt^\alpha} + u_1 + u_3, \\
 C_1 \frac{d^\alpha u_1}{dt^\alpha} + C_2 \frac{d^\alpha u_2}{dt^\alpha} - C_3 \frac{d^\alpha u_3}{dt^\alpha} &= 0, \\
 e_2 &= u_2 + u_3.
 \end{aligned}
 \tag{2.4}$$

The Equations (2.4) can be written in the form

$$\begin{bmatrix} RC_1 & 0 & 0 \\ C_1 & C_2 & -C_3 \\ 0 & 0 & 0 \end{bmatrix} \frac{d^\alpha}{dt^\alpha} \begin{bmatrix} u_1 \\ u_2 \\ u_3 \end{bmatrix} = \begin{bmatrix} -1 & 0 & -1 \\ 0 & 0 & 0 \\ 0 & -1 & -1 \end{bmatrix} \begin{bmatrix} u_1 \\ u_2 \\ u_3 \end{bmatrix} + \begin{bmatrix} 1 & 0 \\ 0 & 0 \\ 0 & 1 \end{bmatrix} \begin{bmatrix} e_1 \\ e_2 \end{bmatrix}.
 \tag{2.5}$$

In this case we have

$$E = \begin{bmatrix} RC_1 & 0 & 0 \\ C_1 & C_2 & -C_3 \\ 0 & 0 & 0 \end{bmatrix}, \quad A = \begin{bmatrix} -1 & 0 & -1 \\ 0 & 0 & 0 \\ 0 & -1 & -1 \end{bmatrix}, \quad B = \begin{bmatrix} 1 & 0 \\ 0 & 0 \\ 0 & 1 \end{bmatrix}.
 \tag{2.6}$$

Note that the matrix E is singular ($\det E = 0$) but the pencil

$$\det[Es - A] = \begin{vmatrix} RC_1s + 1 & 0 & 1 \\ C_1s & C_2s - C_3s & 0 \\ 0 & 1 & 1 \end{vmatrix} = (RC_1s + 1)(C_2 + C_3)s + C_1s
 \tag{2.7}$$

is regular. Therefore, the electrical circuit is a fractional descriptor linear system with regular pencil.

In general case we have the following theorem.

Theorem 2.1. If the fractional electrical circuit contains at least one mesh consisting of branches with only ideal capacitors and voltage sources, then its matrix E is singular.

Proof. Note that the row of E corresponding to the mesh is a zero row. This follows from the fact that the equation written with the use of Kirchhoff's voltage law is an algebraic one.

Example 2.2. Consider the fractional electrical circuit shown on Figure 2.2 with given resistances R_1, R_2, R_3 inductances L_1, L_2, L_3 and source voltages e_1 and e_2 .

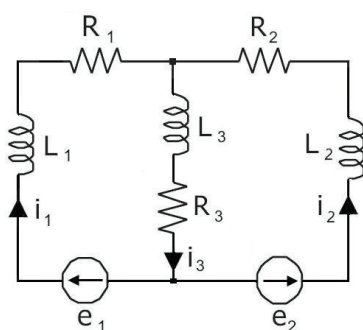

Fig. 2.2. Electrical circuit of Example 2.2

Using Kirchhoff's laws we can write the equations

$$\begin{aligned} e_1 &= R_1 i_1 + L_1 \frac{d^\alpha i_1}{dt^\alpha} + R_3 i_3 + L_3 \frac{d^\alpha i_3}{dt^\alpha}, \\ e_2 &= R_2 i_2 + L_2 \frac{d^\alpha i_2}{dt^\alpha} + R_3 i_3 + L_3 \frac{d^\alpha i_3}{dt^\alpha}, \\ 0 &= i_1 + i_2 - i_3. \end{aligned} \quad (2.8)$$

Equations (2.8) can be written in the form

$$\begin{bmatrix} L_1 & 0 & L_3 \\ 0 & L_2 & L_3 \\ 0 & 0 & 0 \end{bmatrix} \frac{d^\alpha}{dt^\alpha} \begin{bmatrix} i_1 \\ i_2 \\ i_3 \end{bmatrix} = \begin{bmatrix} -R_1 & 0 & -R_3 \\ 0 & -R_2 & -R_3 \\ 1 & 1 & -1 \end{bmatrix} \begin{bmatrix} i_1 \\ i_2 \\ i_3 \end{bmatrix} + \begin{bmatrix} 1 & 0 \\ 0 & 1 \\ 0 & 0 \end{bmatrix} \begin{bmatrix} e_1 \\ e_2 \end{bmatrix}. \quad (2.9)$$

In this case we have

$$E = \begin{bmatrix} L_1 & 0 & L_3 \\ 0 & L_2 & L_3 \\ 0 & 0 & 0 \end{bmatrix}, A = \begin{bmatrix} -R_1 & 0 & -R_3 \\ 0 & -R_2 & -R_3 \\ 1 & 1 & -1 \end{bmatrix}, B = \begin{bmatrix} 1 & 0 \\ 0 & 1 \\ 0 & 0 \end{bmatrix}. \quad (2.10)$$

Note that the matrix E is singular but the pencil

$$\begin{aligned} \det[Es - A] &= \begin{vmatrix} L_1 s + R_1 & 0 & L_3 s + R_3 \\ 0 & L_2 s + R_2 & L_3 s + R_3 \\ -1 & -1 & 1 \end{vmatrix} = [L_1(L_2 + L_3) + L_2 L_3] s^2 + \\ &+ [(L_2 + L_3)R_1 + (L_1 + L_3)R_2 + (L_1 + L_2)R_3] s + R_1(R_2 + R_3) + R_2 R_3 \end{aligned} \quad (2.11)$$

is regular. Therefore, the fractional electrical circuit is a descriptor linear system with regular pencil.

Theorem 2.2. If the fractional electrical circuit contains at least one node with branches with coils then its matrix E is singular.

Proof. Note that the equation written using the current Kirchhoff's current law for this node is an algebraic one and in the matrix E we have zero row.

In general case we have the following theorem.

Theorem 2.3. Every fractional electrical circuit is a descriptor system if it contains at least one mesh consisting of branches with only ideal capacitances and voltage sources or at least one node with branches with coils.

Proof. By Theorem 2.1 the matrix E of the system is singular if the electrical circuit contains at least one mesh consisting of branches with only ideal capacitors and voltage sources. Similarly, by Theorem 2.2 the matrix E is singular if the electrical circuit contains at least one node with branches with coils.

3. Zeroing of the state vector

Consider the fractional descriptor linear circuit described by the Equation (2.2) with regular pencil satisfying (2.3). To the electrical circuit the state-feedback

$$u = Kx, \in \mathfrak{R}^{n \times m} \text{ (gain matrix)} \tag{3.1}$$

is applied and the equation of closed-loop circuit has the form

$$E \frac{d^\alpha x}{dt^\alpha} = (A + BK)x. \tag{3.2}$$

We are looking for a gain matrix K such that state vector $x = x(t)$ of the closed-loop circuit satisfies the condition

$$x(t) = 0 \text{ for } t > 0 \tag{3.3}$$

for any admissible initial conditions and any values of resistances, inductances and capacitances.

It will be shown that there exists a gain matrix K such that the condition (3.3) is satisfied if and only if

$$\text{rank}[E, B] = n, \text{ rank}[Es^\alpha - A, B] = n \text{ for all } s \in C \text{ (the field of complex numbers)}. \tag{3.4}$$

Remark 3.1. The condition (3.4) is satisfied if and only if the matrix $[Es - A, B]$ can be reduced to the matrix $[0 \ I_n]$ by the use of elementary column operations [9].

Theorem 3.1. There exists $K \in \mathfrak{R}^{m \times n}$ satisfying the condition

$$\det[Es^\alpha - (A + BK)] = a \neq 0 \text{ (} a \text{ – a real number independent of } s), \tag{3.5}$$

if and only if the condition (3.4) is met.

Proof is similar to the proof given in [6]. The solution of the problem is based on the following theorem.

Theorem 3.2. There exists a gain matrix $K \in \mathfrak{R}^{m \times n}$ such that (3.3) holds if and only if the condition (3.4) is satisfied.

Proof. By Theorem 3.1 there exists K satisfying (3.5) if and only if the condition (3.4) is met. In this case, using the Laplace transform from (3.2) we obtain

$$X(s) = [Es^\alpha - (A + BK)]^{-1} x_0, \quad (3.6)$$

where

$$X(s) = \mathcal{L}[x(t)] = \int_0^{\infty} x(t)e^{-st} dt$$

is the Laplace transform of $x(t)$ and x_0 is the admissible initial condition.

Taking into account (3.5) we obtain

$$\begin{aligned} X(s) &= \frac{\text{Adj} [Es^\alpha - (A + BK)]}{\det[Es^\alpha - (A + BK)]} x_0 = \frac{\text{Adj} [Es^\alpha - (A + BK)]}{a} x_0 = \\ &= (P_0 + P_1 s^\alpha + \dots + P_q s^{q\alpha}) x_0, \end{aligned} \quad (3.7)$$

where $\text{Adj} [Es^\alpha - (A + BK)]$ denotes the adjoint matrix and $P_k \in \mathfrak{R}^{n \times n}$ for $k = 0, 1, \dots, q$.

Applying the inverse Laplace transform to (3.7) we obtain

$$x(t) = \sum_{k=0}^q P_k x_0 \delta^{(k)}(t) = 0 \quad \text{for } t > 0, \quad (3.8)$$

since $\mathcal{L}[{}^C D_{0+}^\alpha \delta(t)] = s^\alpha$, where $\delta(t)$ is the Dirac impulse and $\delta^{(k)}(t)$ is k -th derivative and ${}^C D_{0+}^\alpha$ denotes the fractional derivative [34].

Example 3.1. Consider the fractional electrical circuit shown in Figure 3.1 with given resistance R , capacitances C_1 , C_2 and source voltage $e = e(t)$.

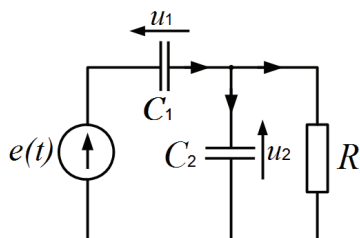

Fig. 3.1. Electrical circuit of Example 3.1

Using Kirchhoff's laws for the electrical circuit we can write the equations

$$C_1 \frac{d^\alpha u_1}{dt^\alpha} - C_2 \frac{d^\alpha u_2}{dt^\alpha} = \frac{u_2}{R}, \tag{3.9}$$

$$u_1 + u_2 = e,$$

which can be rewritten in the form

$$E \frac{d^\alpha}{dt^\alpha} \begin{bmatrix} u_1 \\ u_2 \end{bmatrix} = A \begin{bmatrix} u_1 \\ u_2 \end{bmatrix} + Be, \tag{3.10a}$$

where

$$E = \begin{bmatrix} C_1 & -C_2 \\ 0 & 0 \end{bmatrix}, \quad A = \begin{bmatrix} 0 & \frac{1}{R} \\ -1 & -1 \end{bmatrix}, \quad B = \begin{bmatrix} 0 \\ 1 \end{bmatrix}. \tag{3.10b}$$

The condition (3.4) is satisfied since

$$\text{rank} [E, B] = \text{rank} \begin{bmatrix} C_1 & -C_2 & 0 \\ 0 & 0 & 1 \end{bmatrix} = 2,$$

$$\text{rank} [Es^\alpha - A, B] = \text{rank} \begin{bmatrix} s^\alpha C_1 - s^\alpha C_2 - \frac{1}{R} & 0 \\ 1 & 1 & 1 \end{bmatrix} = 2, \quad \text{for all } s \in C. \tag{3.11}$$

For the gain matrix $K = [k_1 \ k_2]$ the closed-loop system matrix has the form

$$[Es^\alpha - (A + BK)] = \begin{bmatrix} s^\alpha C_1 - s^\alpha C_2 - \frac{1}{R} & \\ 1 - k_1 & 1 - k_2 \end{bmatrix} \tag{3.12}$$

and its determinant is equal to a real number $a \neq 0$

$$\det[Es^\alpha - (A + BK)] = s^\alpha [C_1(1 - k_2) + C_2(1 - k_1)] + \frac{1 - k_1}{R} = a \tag{3.13}$$

$$\text{for } k_1 \neq \text{ and } k_2 = \frac{C_1 + C_2(1 - k_1)}{C_1}. \tag{3.14}$$

Therefore, for the state feedback matrix $K = [k_1 \ \dots \ k_2]$ with k_1 and k_2 defined by (3.14) we have $u_1(t) = 0, u_2(t) = 0$ for $t > 0$.

Example 3.2. Consider the fractional electrical circuit shown in Figure 3.2 with given resistances R_1, R_2 , inductances L_1, L_2 and source current $i_s(t) = i_s$.

Using Kirchhoff's laws for the electrical circuit we can write the equations

$$R_1 i_1 + L_1 \frac{d^\alpha u_1}{dt^\alpha} - R_2 i_2 - L_2 \frac{d^\alpha i_2}{dt^\alpha} = 0, \quad (3.15)$$

$$i_s = i_1 + i_2,$$

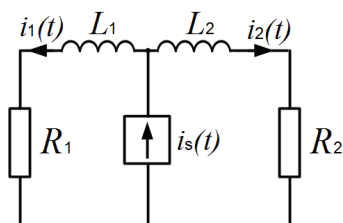

Fig. 3.2. Electrical circuit of Example 3.2

which can be rewritten in the form

$$E \frac{d^\alpha}{dt^\alpha} \begin{bmatrix} i_1 \\ i_2 \end{bmatrix} = A \begin{bmatrix} i_1 \\ i_2 \end{bmatrix} + B i_s, \quad (3.16a)$$

where

$$E = \begin{bmatrix} L_1 & -L_2 \\ 0 & 0 \end{bmatrix}, \quad A = \begin{bmatrix} -R_1 & R_2 \\ -1 & -1 \end{bmatrix}, \quad B = \begin{bmatrix} 0 \\ 1 \end{bmatrix}. \quad (3.16b)$$

The condition (3.4) is satisfied since

$$\text{rank} [E s^\alpha - A, B] = \text{rank} \begin{bmatrix} R_1 + s^\alpha L_1 & -R_2 - s^\alpha L_2 & 0 \\ 1 & 1 & 1 \end{bmatrix} = 2, \quad \text{for all } s \in C. \quad (3.17)$$

For the gain matrix $K = [k_1 \ k_2]$ the closed-loop system matrix has the form

$$\text{rank} [E, B] = \text{rank} \begin{bmatrix} L_1 & -L_2 & 0 \\ 0 & 0 & 1 \end{bmatrix} = 2, \quad (3.18)$$

$$[E s^\alpha - (A + BK)] = \begin{bmatrix} R_1 + s^\alpha L_1 & -R_2 - s^\alpha L_2 \\ 1 - k_1 & 1 - k_2 \end{bmatrix}$$

and its determinant is equal to a real number $a \neq 0$

$$\det[E s^\alpha - (A + BK)] = (R_1 + s^\alpha L_1)(1 - k_2) + (R_2 + s^\alpha L_2)(1 - k_1) = a \quad (3.19)$$

for k_1, k_2 satisfying the equation

$$\begin{bmatrix} L_2 & L_1 \\ R_2 & R_1 \end{bmatrix} \begin{bmatrix} k_1 \\ k_2 \end{bmatrix} = \begin{bmatrix} L_1 + L_2 \\ (R_1 + R_2) - a \end{bmatrix}. \quad (3.20)$$

The solution of (3.20) has the form

$$\begin{bmatrix} k_1 \\ k_2 \end{bmatrix} \begin{bmatrix} L_2 & L_1 \\ R_2 & R_1 \end{bmatrix}^{-1} = \begin{bmatrix} L_1 + L_2 \\ (R_1 + R_2) - a \end{bmatrix} = \begin{bmatrix} 1 + \frac{L_1 a}{R_1 L_2 - R_2 L_1} \\ 1 - \frac{L_2 a}{R_1 L_2 - R_2 L_1} \end{bmatrix}. \quad (3.21)$$

Therefore, for the state feedback $K = [k_1 \ k_2]$ with k_1 and k_2 given by (3.21) we have $i_1(t) = 0$, $i_2(t) = 0$ for $t > 0$.

Example 3.3. Consider the fractional electrical circuit shown in Figure 3.3 with given resistances R, R_1, R_2 ; inductances L_1, L_2 ; capacitances C_1, C_2 ; source voltage $e = e(t)$ and source current $i_s = i_s(t)$.

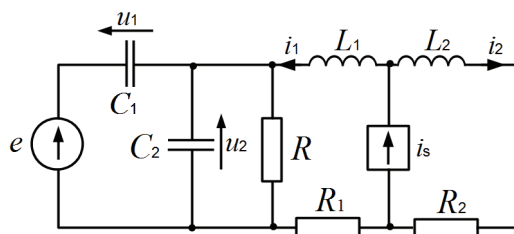

Fig. 3.3. Electrical circuit of Example 3.3

Using Kirchhoff's laws for the electrical circuit we can write the equations

$$\begin{aligned} C_1 \frac{d^\alpha u_1}{dt^\alpha} - C_2 \frac{d^\alpha u_2}{dt^\alpha} &= \frac{u_2}{R} - i_1, \\ u_1 + u_2 &= e, \\ R_1 i_1 + u_2 + L_1 \frac{d^\beta i_1}{dt^\beta} &= R_2 i_2 + L_2 \frac{d^\beta i_2}{dt^\beta}, \\ i_s &= i_1 + i_2, \end{aligned} \quad (3.22)$$

which can be written in the form

$$E \begin{bmatrix} \frac{d^\alpha u_1}{dt^\alpha} \\ \frac{d^\alpha u_2}{dt^\alpha} \\ \frac{d^\beta i_1}{dt^\beta} \\ \frac{d^\beta i_2}{dt^\beta} \end{bmatrix} = A \begin{bmatrix} u_1 \\ u_2 \\ i_1 \\ i_2 \end{bmatrix} + B \begin{bmatrix} e \\ i_s \end{bmatrix}, \quad \begin{matrix} 0 < \alpha < 1 \\ 0 < \beta < 1 \end{matrix}, \quad (3.23a)$$

where

$$E = \begin{bmatrix} C_1 - C_2 & 0 & 0 & 0 \\ 0 & 0 & 0 & 0 \\ 0 & 0 & L_1 & -L_2 \\ 0 & 0 & 0 & 0 \end{bmatrix}, \quad A = \begin{bmatrix} 0 & \frac{1}{R} & -1 & 0 \\ -1 & -1 & 0 & 0 \\ 0 & -1 & -R_1 & R_2 \\ 0 & 0 & -1 & -1 \end{bmatrix}, \quad B = \begin{bmatrix} 0 & 0 \\ 1 & 0 \\ 0 & 0 \\ 0 & 1 \end{bmatrix}. \quad (3.23b)$$

The condition (3.4) is satisfied since

$$\text{rank}[E, B] = \text{rank} \begin{bmatrix} C_1 - C_2 & 0 & 0 & 0 & 0 & 0 \\ 0 & 0 & 0 & 0 & 1 & 0 \\ 0 & 0 & L_1 & -L_2 & 0 & 0 \\ 0 & 0 & 0 & 0 & 0 & 1 \end{bmatrix} = 4$$

and

$$\text{rank} \left[E \begin{bmatrix} I_2 s^\alpha & 0 \\ 0 & I_2 s^\beta \end{bmatrix} - (A + BK) \right] = \begin{bmatrix} s^\alpha C_1 - s^\alpha C_2 - \frac{1}{R} & 1 & 0 \\ 1 - k_{11} & 1 - k_{12} & -k_{13} & -k_{14} \\ 0 & 1 & s^\beta L_1 + R_1 - s^\beta L_2 - R_2 \\ -k_{21} & -k_{22} & 1 - k_{23} & 1 - k_{24} \end{bmatrix}. \quad (3.24)$$

for all $s \in C$.

For the gain matrix

$$K = \begin{bmatrix} k_{11} & k_{12} & k_{13} & k_{14} \\ k_{21} & k_{22} & k_{23} & k_{24} \end{bmatrix} \quad (3.25)$$

the closed-loop system matrix has the form

$$\left[E \begin{bmatrix} I_2 s^\alpha & 0 \\ 0 & I_2 s^\beta \end{bmatrix} - (A + BK) \right] = \begin{bmatrix} s^\alpha C_1 - s^\alpha C_2 - \frac{1}{R} & 1 & 0 \\ 1 - k_{11} & 1 - k_{12} & -k_{13} & -k_{14} \\ 0 & 1 & s^\beta L_1 + R_1 - s^\beta L_2 - R_2 \\ -k_{21} & -k_{22} & 1 - k_{23} & 1 - k_{24} \end{bmatrix}. \quad (3.26)$$

Assuming $k_{13} = k_{14} = k_{21} = k_{22} = 0$, we obtain the determinant of the matrix (3.26)

$$\begin{aligned} \det \left[E \begin{bmatrix} I_2 s^\alpha & 0 \\ 0 & I_2 s^\beta \end{bmatrix} - (A + BK) \right] &= \begin{vmatrix} s^\alpha C_1 - s^\alpha C_2 - \frac{1}{R} & 1 & 0 \\ 1 - k_{11} & 1 - k_{12} & 0 & 0 \\ 0 & 1 & s^\beta L_1 + R_1 - s^\beta L_2 - R_2 \\ 0 & 0 & 1 - k_{23} & 1 - k_{24} \end{vmatrix} = \\ &= \left\{ s^\alpha [C_1(1 - k_{12}) + C_2(1 - k_{11})] + \frac{1}{R}(1 - k_{11}) \right\} \times \\ &\times \left\{ s^\beta [L_1(1 - k_{24}) + L_2(1 - k_{23})] + R_1(1 - k_{24}) + R_2(1 - k_{23}) \right\} + (1 - k_{11})(1 - k_{24}) = \\ &= a_1 a_2 + (1 - k_{11})(1 - k_{24}). \end{aligned} \quad (3.27)$$

where

$$\begin{aligned} C_1(1 - k_{12}) + C_2(1 - k_{11}) &= 0, & \frac{1}{R}(1 - k_{11}) &= a_1, \\ L_1(1 - k_{24}) + L_2(1 - k_{23}) &= 0, & R_1(1 - k_{24}) + R_2(1 - k_{23}) &= a_2. \end{aligned} \tag{3.28}$$

From (3.28) we have $k_{11} = 1 - a_1 R$ and

$$\begin{bmatrix} C_1 & 0 & 0 \\ 0 & L_2 & L_1 \\ 0 & R_2 & R_1 \end{bmatrix} \begin{bmatrix} k_{12} \\ k_{23} \\ k_{24} \end{bmatrix} = \begin{bmatrix} C_1 + RC_2 a_1 \\ L_1 + L_2 \\ R_1 + R_2 - a_2 \end{bmatrix}. \tag{3.29}$$

The Equation (3.29) has the solution

$$\begin{bmatrix} k_{12} \\ k_{23} \\ k_{24} \end{bmatrix} \begin{bmatrix} C_1 & 0 & 0 \\ 0 & L_2 & L_1 \\ 0 & R_2 & R_1 \end{bmatrix}^{-1} \begin{bmatrix} C_1 + RC_2 a_1 \\ L_1 + L_2 \\ R_1 + R_2 - a_2 \end{bmatrix} = \begin{bmatrix} 1 + \frac{RC_2 a_1}{C_1} \\ 1 + \frac{L_1 a_2}{R_1 L_2 - R_2 L_1} \\ 1 - \frac{L_2 a_2}{R_1 L_2 - R_2 L_1} \end{bmatrix}. \tag{3.30}$$

if

$$\det \begin{bmatrix} C_1 & 0 & 0 \\ 0 & L_2 & L_1 \\ 0 & R_2 & R_1 \end{bmatrix} = C_1(R_1 L_2 - R_2 L_1) \neq 0. \tag{3.31}$$

Therefore, for the gain matrix (3.25) with $k_{13} = k_{14} = k_{21} = k_{22} = 0$, $k_{11} = 1 - a_1 R$, and k_{12} , k_{23} , k_{24} , given by (3.30) we have $u_1(t) = 0$, $u_2(t) = 0$, $i_1(t) = 0$, $i_2(t) = 0$ for $t > 0$.

Remark 3.2. For the fractional electrical circuit shown in Figure 2.1 the condition (3.4) is not satisfied since

$$\text{rank} [Es^\alpha - A, B] = \text{rank} \begin{bmatrix} s^\alpha RC_1 + 1 & 0 & 1 & 1 & 0 \\ s^\alpha C_1 & s^\alpha C_2 & -s^\alpha C_3 & 0 & 0 \\ 0 & 1 & 1 & 0 & 1 \end{bmatrix} = 2, \text{ for all } s \in \mathbb{C}. \tag{3.32}$$

Remark 3.3. The method based on transformation of the matrix $Es^\alpha - A$ to upper Hessenberg form can be also applied to solving the problem [22].

4. Concluding remarks

The problem of zeroing of the state variables in descriptor electrical circuits by suitable choice of state feedbacks has been formulated and solved. It has been shown that there exists a gain matrix such that (3.3) holds if and only if the condition (3.4) is satisfied. The choice of

the gain matrix of state feedbacks has been demonstrated in three examples of descriptor electrical circuits. These considerations can be extended to discrete-time linear systems.

Acknowledgment

This work was supported by National Science Centre in Poland under work No N N514 6389 40.

References

- [1] Dodig M., Stosic M., *Singular systems state feedbacks problem*. Linear Algebra and its Applications 431(8): 1267-1292 (2009).
- [2] Dai L., *Singular control systems*. Lecture Notes in Control and Inform. Sci. 118, Springer-Verlag, Berlin (1989).
- [3] Fahmy M.M., O'Reill J., *Matrix pencil of closed-loop descriptor systems: infinite-eigenvalues assignment*. Int. J. Control 49(4): 1421-1431 (1989).
- [4] Gantmacher F.R., *The Theory of Matrices*. Vol. I, II. K.A. Hirsch (transl.), Chelsea Publishing Co., New York (1959).
- [5] Guang-Ren Duan, *Analysis and Design of Descriptor Linear Systems*. Springer (2010).
- [6] Kaczorek T., *Elimination of finite eigenvalues of strongly singular systems by feedbacks in linear systems*. Int. Conf. Mathematical Modelling as Means of Power Consumption, 18-23.06, Lwow, pp. 73-77 (2001).
- [7] Kaczorek T., *Infinite eigenvalue assignment by an output feedback for singular systems*. Int. J. Appl. Math. Comput. Sci. 14(1): 19-23 (2004).
- [8] Kaczorek T., *Linear Control Systems: Analysis of Multivariable Systems*. Research Studies Press and J. Wiley & Sons, New York (1992).
- [9] Kaczorek T., *Polynomial and Rational Matrices. Applications in Dynamical Systems Theory*, Springer-Verlag, London (2007).
- [10] Kaczorek T., *Positivity of descriptor linear systems with regular pencils*. Poznan University Technology Academic Journals, Electrical Engineering 69: 9-22 (2012).
- [11] Kaczorek T., *Realization problem for singular positive continuous-time systems with delays*. Control and Cybernetics 36(1): 47-57 (2007).
- [12] Kaczorek T., *Selected Problems of Fractional Systems Theory*. Springer-Verlag, Berlin (2011).
- [13] Kaczorek T., *Checking of the positivity of descriptor linear systems by the use of the shuffle algorithm*, Archives of Control Sciences 21(3): 287-298 (2011).
- [14] Kaczorek T., *Positivity and reachability of fractional electrical circuits*, Acta Mechanica et Automatica 5(2): 42-51 (2011).
- [15] Kaczorek T., *Reduction and decomposition of singular fractional discrete-time linear systems*. Acta Mechanica et Automatica 5(4): 62-66 (2011).
- [16] Kaczorek T., *Singular fractional discrete-time linear systems*. Control and Cybernetics 40(3): 753-761 (2011).
- [17] Kaczorek T., *Singular fractional linear systems and electrical circuits*. Int. J. Appl. Math. Comput. Sci. 21(2): 379-384 (2011).
- [18] Kaczorek, T., *Fractional positive continuous-time linear systems and their reachability*. Int. J. Appl. Math. Comput. Sci. 18(2): 223-228 (2008).
- [19] Kaczorek T., *Positive stable descriptor continuous-discrete 2D linear systems*. Electrical Review 88(12a): 137-142 (2012).
- [20] Kaczorek T., *Reachability and controllability to zero of cone fractional linear systems*. Archives of Control Sciences 17(4): 357-367 (2007).
- [21] Kaczorek T., *Zeroing of state variables in descriptor linear electrical circuits by state-feedbacks*. Electrical Review 89(10): 200-203 (2013).

- [22] Kaczorek T., *Infinite eigenvalue assignment by output-feedbacks for singular systems*. Proc. of Silesian Technical University pp. 64-71 (2004).
- [23] Kucera V., Zagalak P., *Fundamental theorem of state feedback for singular systems*. Automatica 24(5): 653-658 (1988).
- [24] Luenberger D.G., *Time-invariant descriptor systems*, Automatica 14(5): 473-480 (1978).
- [25] Miller K.S., Ross B., *An Introduction to the Fractional Calculus and Fractional Differential Equations*, Wiley, New York (1993).
- [26] Nashimoto K., *Fractional Calculus*. Descartes Press, Koriama (1984).
- [27] Oldham K.B., Spanier J., *The Fractional Calculus: Integrations and Differentiations of Arbitrary Order*. Academic Press, New York (1974).
- [28] Ortigueira M.D., *Fractional discrete-time systems*. Proc. of the IEEE ICASSP-97, Munich, Germany 3, pp. 2241-2244 (1997).
- [29] Ostalczyk P., *The non-integer difference of the discrete-time function and its application to the control system synthesis*, Int. J. Systems Science 31(15): 1551-1561 (2000).
- [30] Ostalczyk P., *Fractional-order backward difference equivalent forms. Part I – Horners Form*. Proc. of 1st IFAC Workshop on Fractional Differentiation and its Applications FDA'04, Ensierb, Bordeaux, France, pp. 342-347 (2004).
- [31] Ostalczyk P., *Fractional-order backward difference equivalent forms Part II – Polynomial Form*. Proc. of 1st IFAC Workshop on Fractional Differentiation and its Applications FDA'04, Ensierb, Bordeaux, France, pp. 348-353 (2004).
- [32] Oustaloup A., *La commande CRONE*. Hermès, Paris (1991).
- [33] Oustaloup A., *La dérivation non entière: théorie, synthèse et applications*. Hermès, Paris (1995).
- [34] Podlubny I., *Fractional Differential Equations*. Academic Press, San Diego (1999).
- [35] Samko S.G., Kilbas A.A., Marichev O.I., *Fractional integrals and derivatives: Theory and applications*. Gordon and Breach Science Publishers (1993).
- [36] Sierociuk D., Dzieliński A., *Fractional Kalman filter algorithm for the states parameters and order of fractional system estimation*, Int. J. Appl. Math. Comput. Sci. 16(1): 129-140 (2006).
- [37] Vinagre B.M., Monje C.A., Calderón A.J., *Fractional order systems and fractional order control actions*. Lecture 3 IEEE CDC'02 TW#2: Fractional calculus Applications in Automatic Control and Robotics (2002).
- [38] Vinagre B.M., Feliu V., *Modeling and control of dynamic systems using fractional calculus: Application to electrochemical processes and flexible structures*. In Proc. 41st IEEE Conf. Decision and Control 1: 214-239 (2002).
- [39] Van Dooren P., *The computation of Kronecker's canonical form of a singular pencil*. Linear Algebra and Its Applications 27: 103-140 (1979).