

ADAM KANCIRUK*

METHODS FOR EVALUATING GROUND DISLOCATIONS IN MINING AREAS

METODA OCENY PRZEMIESZCZEŃ BUDOWLI NA TERENIE GÓRNICZYM

Underground exploitation of natural resources results in disturbance of the original equilibrium in the strata and leads to the emergence of the so-called subsidence troughs on the ground surface (Florkowska, 2010). Due to ground distortion, buildings located in these areas suffer damages and deformations, including angular tilts. An instrument for measuring constructions' angles of slope is known as an inclinometer. The prototypical vibrating wire inclinometer discussed in the present paper has three wires (each of them cooperating with one electromagnet) on which a weight – attached to an arm – is suspended. Thanks to this, it comes of use in a range of procedures, such as measuring object inclines, or determining the angle between the plane of the incline and the assumed reference direction. As any other vibrating wire transducer, an inclinometer cooperates with a proper electronic device which makes it possible to measure the vibration period for each wire separately. The device is also used for the inclinometer's calibration. Additionally, the paper provides an example of an inclinometer's use in measuring the angular tilt of a historical church tower located in the area affected by underground mining operations connected with exploitation of hard coal.

Keywords: influence of underground mining on buildings, mining damages, vibrating wire transducers, electronic measuring devices

Podziemna eksploatacja kopalin powoduje naruszenie pierwotnej równowagi w górotworze i powstawanie na powierzchni terenu tzw. niecek osiadania (Florkowska, 2010). Wskutek deformacji podłoża, budowle posadowione w tych rejonach doznają uszkodzeń i deformacji – w tym nachyleń. Urządzeniem do pomiaru nachylenia konstrukcji budowlanych jest inklinometr. Opisany w artykule prototypowy inklinometr strunowy zawiera 3 struny, na których zawieszony jest za pośrednictwem ramienia ciężarek. Z każdą struną współpracuje indywidualny elektromagnes. Dzięki temu, inklinometr może być przydatny do pomiaru nachylenia konstrukcji, oraz określenia kąta między płaszczyzną w którym to nachylenie zachodzi i wstępnie przyjętym kierunkiem odniesienia. Jak każdy inny przetwornik strunowy, współpracuje on z odpowiednim elektronicznym urządzeniem, umożliwiającym pomiar okresu drgań każdej ze strun z osobna. Przy pomocy tego urządzenia inklinometr jest też wzorcowany. W artykule opisano też

* STRATA MECHANICS RESEARCH INSTITUTE OF THE POLISH ACADEMY OF SCIENCES, UL. REYMONTA 27, 30-059 KRAKÓW, POLAND

przykład zastosowania inklinometru do pomiaru nachylenia wieży zabytkowego kościoła, znajdującego się na terenie poddanym oddziaływaniu podziemnej eksploatacji węgla kamiennego.

Słowa kluczowe: wpływ podziemnej eksploatacji na budynki, szkody górnicze, przetworniki strunowe, elektroniczna aparatura pomiarowa

1. Introduction

Inclinometers represent a type of transducers used for geotechnical measurements. Within this group, an established position is held by vibrating wire transducers, which have been used for geotechnical measurements for 90 years. Between 1920 and 1921, a German company called “Maihak” developed first vibrating wire transducers marked as MDS (*Maihak Dauerschwingende Saite*) (<http://www.funkstunde.com...>), which served for measuring dislocations, force, pressure, inclines, and temperature. In the 2nd half of the 20th century, the production of various vibrating wire transducers was the domain of the Laboratory of Science Equipment of the Jagiellonian University in Kraków (Zakład Aparatury Naukowej Uniwersytetu Jagiellońskiego – ZAN UJ) (*Polska aparatura...*). At present, vibrating wire transducers and cooperating electronic equipment are produced by a range of world-renowned companies, such as the US-based “Geokon” (<http://www.geokon.com>) and the British company Gage Technique (<http://www.gage-technique.ae...>).

The popular types of vibrating wire inclinometers – for example, “the SCK-type vibrating wire sensor for measuring angular slopes” produced by ZAN UJ (*Polska aparatura...*), or the Geokon 6300-type inclinometer (<http://www.geokon.com/products...>) – are equipped with a pendulum suspended on a hinge inside a casing. The position of the pendulum’s weight is stabilized by means of a single measuring vibrating wire. Any change in the tilt of the inclinometer results in a change in the measuring wire’s tension, and, what follows, a change of the frequency of its free vibration. Both these inclinometers can be used for measuring tilt in a single plane, only. An example of a device measuring tilt in any plane is “the SCIR-type vibrating wire sensor-inclinometer” (*Polska aparatura...*) produced by ZAN UJ. In this instrument, the weight of the pendulum is fixed to the casing not by means of a hinge, but a resilient beam and three vibrating wires. Depending on the tilt of the casing, the beam bends, which results in the wires’ stretching, each to a different degree. Due to a wide measuring range (and limited resolution), the SCIR-type inclinometer is not used for measuring the tilt of buildings, but for measuring a vertical borehole deviation. However, vibrating wires themselves are resilient elements on which a pendulum can be suspended. Lack of any other support for the pendulum might prove conducive to high measuring accuracy of the device.

2. The concept of a vibrating wire inclinometer

Figure 1 presents construction assumptions of a vibrating wire inclinometer. Shield *I* is tightly tied to construction *K*, whose angular tilt changes are to be investigated. To the shield, three clamps *2* of the upper ends of three measuring wires *3* are fastened. The lower ends of the wires are fastened in similar clamps *5* of shield *6*. All the wires are stretched at 120° intervals, parallel to the axis going through the centers of shields *I* and *6*, and distance *r* between each wire

and the shield is the same in all three cases. Lower shield 6 is weighed down with a pendulum consisting of arm 7 and weight 8. Free oscillations of the pendulum are reduced by suppressor 9, which comprises a shield immersed in a fluid of adequate viscosity.

Each wire is equipped with its own electromagnet, whose role is to incite the wire's vibrations and transform them into an electric signal. Electromagnets 4 are fastened to ring 1 in a manner that is not visible in the picture (i.e. Fig. 1).

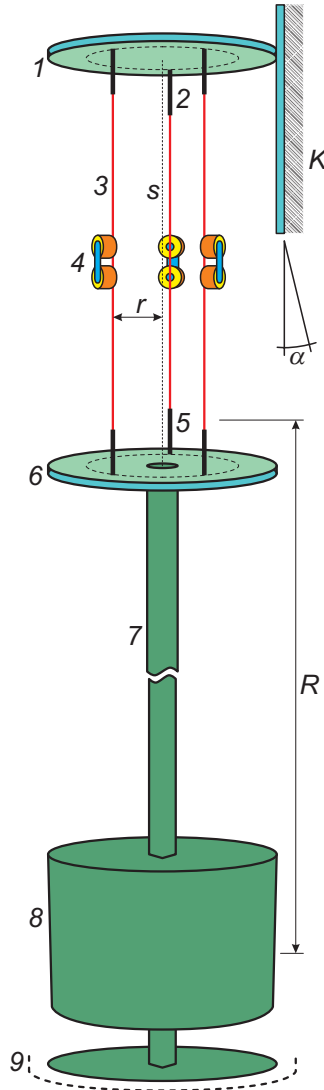

Fig. 1 The concept of a vibrating wire inclinometer. *K* – examined construction, 1 – upper shield, 2 – upper clamp, 3 – vibrating wire, 4 – electromagnet, 5 – lower clamp, 6 – lower shield, 7 – arm, 8 – weight, 9 – suppressor

The formulas for relations between the quantities describing deformations of the wires depending on the angle of incline of shield l (and construction K) were deduced in paper (Kanciruk, 2009). Thus, only the end formulas shall be provided in the present section. To ensure the maximum sensitivity of the device, one needs to properly establish distance r between wires 3 and axis s . It can be demonstrated that, for the following determined parameters:

R — distance between the lower end of the active length of the wires and the center of the weight's mass
 m — weight's mass
 g — acceleration of gravity,
 l — active length of the wire,
 S — cross-sectional area of the wire;
 E — Young's modulus of the material of which the wires are made,
 optimum distance r equals:

$$r = \sqrt{\frac{2Rmgl}{3SE}} \quad (1)$$

If construction K inclines within the plane determined by one of the vibrating wires and axis s , the angle of incline being α , deformation ε of the very same wire is going to be:

$$\varepsilon = \sqrt{\frac{Rmg}{6SEl}} \sin \alpha \quad (2)$$

For the remaining wires, the deformation is going to be twice as less, and will have an opposite sign.

For sample values:

$R = 340$ mm,

$m = 4.35$ kg,

$g = 9.81$ m/s²,

$l = 128$ mm,

$S = 0.0314$ mm² (a wire of a 0.2 mm diameter),

$E = 220$ GPa,

$\alpha = 1^\circ$,

optimum distance r equals 13.4 mm, and deformation ε of the wire equals 0.9124%. Thus, theoretically determined sensitivity of inclinometer A equals:

$$A = 0.9124 \text{ } \%/^\circ \quad (3)$$

The tension of one of the wires, caused by the weight of the pendulum, equals:

$$\sigma = \frac{mg}{3S} \quad (4)$$

Supplying the above values – m , g and S – into formula (4) yields tension $\sigma = 453$ MPa. If a vibrating wire is made of steel of density $\rho = 7870$ kg/m³, the frequency of proper vibration of that wire, calculated from formula (Crawford, 1973):

$$f = \frac{1}{2l} \sqrt{\frac{\sigma}{\rho}} \quad (5)$$

is going to be 937 Hz, and the period – 1067.3 μ s. When measuring that period with resolution being 10 ns, one obtains a theoretical resolution of the measurement of the inclinometer's tilt, close to its neutral position. This definition equals 0.15 second of arc.

Knowing the values of vibration periods T_1 , T_2 and T_3 of particular vibrating wires, one can calculate angle of tilt α of construction K in relation to the vertical, as well as angle θ between the plane of this tilt and the preliminarily assumed reference direction. The following formulas were derived with the assumption that the sum of the wires' deformations, caused by the inclinometer's tilt in relation to the vertical, equals zero:

$$\varepsilon_1 + \varepsilon_2 + \varepsilon_3 = 0 \quad (6)$$

Let us assume that the preliminarily assumed reference direction is marked out by a half line perpendicular to axis s and going through the axis of vibrating wire 1. Angle θ can be calculated on the basis of one of the following formulas:

$$\theta = \arctan \left(-\frac{1}{\sqrt{3}} \left(2 \frac{T_1^2}{T_2^2} + 1 \right) \right) \quad (7)$$

or

$$\theta = \arctan \frac{1}{\sqrt{3}} \left(2 \frac{T_1^2}{T_3^2} + 1 \right) \quad (8)$$

or

$$\theta = \arctan \left(\frac{1 - \frac{T_2^2}{T_3^2}}{\sqrt{3} \left(1 + \frac{T_2^2}{T_3^2} \right)} \right) \quad (9)$$

Similarly, knowing angle θ , we can calculate angle of tilt α of construction K in relation to the vertical in three manners:

$$\alpha = \arcsin \left(\frac{8l^3 \gamma}{ET_1^2 r \cos \theta} \right) \quad (10)$$

or:

$$\alpha = \arcsin \left(\frac{8l^3 \gamma}{ET_2^2 r \cos(\theta + 120^\circ)} \right) \quad (11)$$

or:

$$\alpha = \arcsin \left(\frac{8l^3\gamma}{ET_3^2 r \cos(\theta + 240^\circ)} \right) \quad (12)$$

Angle θ depends on the relationship between the squares of the vibration periods of two of the three measuring wires. Knowing angle θ , one can calculate angle α on the basis of the vibration period of one wire, only – however, the sum of all the wires' deformations resulting from the construction tilt equals zero. Therefore, any factor causing the same change of the apparent (i.e. stemming from the measurement) deformations of all the wires (an example of such a factor is temperature) does not influence the values of angles α and θ . Thus, an inclinometer in which the pendulum is suspended on three wires is a self-temperature compensation system.

3. Calibrating a prototypical inclinometer

On the basis of Figure 1 and numerical data provided in the previous section of this paper, a prototypical inclinometer was built. In the process, inexpensive and widely available materials were used. Figure 2 is a photograph of the mechanical system of the upper part of the inclinometer in question.

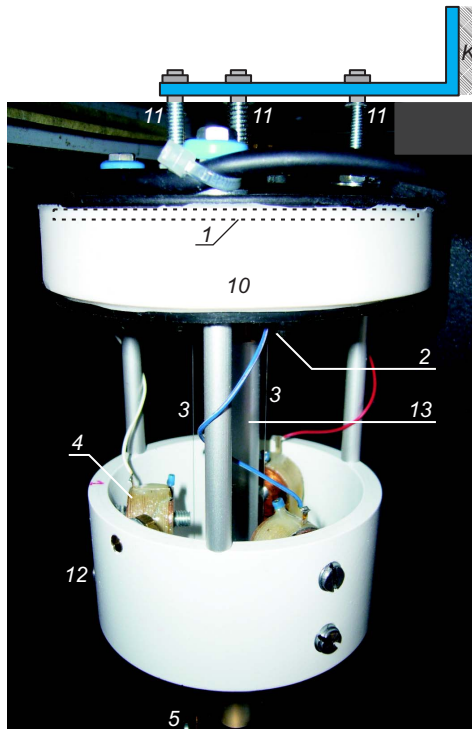

Fig. 2. Prototypical inclinometer – the upper part

The inclinometer is attached to investigated construction K by means of angular rack and system of three precision-made screws II , due to which initial positioning of the device is possible. The screws are driven into upper shield I , covered with the cap of casing 10 (together with the seal). To the shield, clamp 2 – used for all wires and made up of a section of a hexagonal metal profile and three clamps. Due to the dimensions of the profile, distance r was reduced to 12.1 mm, which brought about a slight decrease in theoretically determined sensitivity A (formula 3) – from 0.9124 ‰/°, do 0.907 ‰/°. Vibrating wires 3 (only two of them are visible in the photograph) have their lower ends fixed in clamp 5 , identical with clamp 2 . To this clamp, arm 7 of the pendulum is attached (Fig. 1) – thus, the clamp serves also as the lower shield. Electromagnets 4 are placed on the internal surface of ring 12 , which is fastened to the upper shield. When the inclinometer is tilted, the distance between their pole shoes and the wires changes slightly – however, this has no noticeable effect on the measurements of the wires' vibration periods. The terminals of the electromagnets were connected to a four-core cable (with one core shared – the colours of the remaining cores were assigned to particular wires and marked as “yellow”, “red”, and “green”). Suspending a heavy pendulum (4.35 kg) on a system of thin wires can cause damage (permanent bending, or even snapping) to the wires during transport. Therefore, the system was equipped with a locking mechanism, which – by means of a bolt not visible in the photograph – locks together both clamps of the wires to the endings of tube 13 , reducing the load on the wires. Once the whole system has been attached to the investigated construction, the locking mechanism is deactivated.

A shiftable suspension of the inclinometer II , applied in the system, proved to be a such a precise mechanism that it was used in the process of the initial calibration of the device. During the calibration, the tilts of the inclinometer were changed in planes cutting through axis s and the axes of each of wires 3 (Fig. 1). On the basis of the measurements of wire vibration periods, the wire deformations were calculated, with the following formula:

$$\varepsilon = \frac{4l^2\gamma}{ET^2} \quad (13)$$

Figure 3 presents the results of the inclinometer's calibration in the situation when the inclinometer was tilted in the plane cutting through axis s (Fig. 1) and the axis of the “yellow” wire.

In comparison with the theoretically determined sensitivity coefficient A (0.907 ‰/°), the empirically determined coefficient A_Y (0.835 ‰/°) is lower by mere 8%. The slope coefficients of the characteristics of the “red” wire (0.406 ‰/°) and the “green” wire (0.429 ‰/°) are approximately two times lower than the slope coefficient of the characteristics of the “yellow” wire. The average coefficient for these two wires is 0.4175 ‰/°, which is half the value of the coefficient of the „yellow” wire.

The difference between the results obtained when tilting the inclinometer in the planes cutting through axis s (Fig. 1) and the axes of the “red” and “green” wire, and the results presented above, was 0.5% at the maximum. On the basis of formulas 6, 7, and 10, as well as the determined value of $A_Y = 0.835$ ‰/°, an appropriate program was written for calculating angle θ [°] in relation to the direction of north and the degree of the construction's angular tilt $\sin \alpha$ [%], depending on the value of the vibration periods of the particular wires of the inclinometer. The program was written in the Turbo Pascal for Windows programming language.

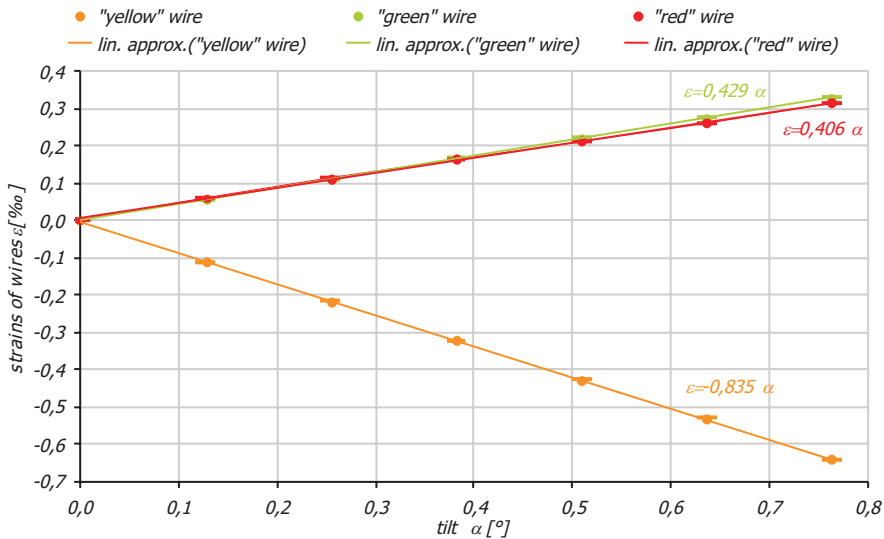

Fig. 3. Inclinometer's characteristics

4. Practical usage of the prototypical inclinometer

The prototypical inclinometer was used in observation of the angular tilt of the tower of a historical church built in an area affected by underground exploitation of hard coal. The church, erected towards the end of the 19th century, is an example of the neo-Gothic style. The edifice is located at 1 Matki Ewy Street, Bytom-Miechowice, and belongs to the local parish of the Evangelical Church of the Augsburg Confession. Mining activity in the Miechowice region started almost 200 years ago, with the exploitation of calamite. Since the beginning of the 20th century, hard coal has been exploited there by means of the longwall mining (there are 13 exploited seams altogether). The depressions in the vicinity of the church (6-7 m) are quite minor in comparison with the maximum depressions in the Miechowice area (they can reach even 30 m) – however, stability of the edifice is threatened by significant nonhomogeneity of the terrain deformations.

Figure 4 presents a schematic plan of the church in question, its situation in relation to the mining fields of walls 72a and 97a (totally exploited in 2008 and 2010), and the depiction of changes in the angular tilt of the tower. The first field, located at the depth of ca. 600 m and marked blue and green, is situated in a most unfortunate way, as one of its edges (the blue line) borders on the area where the church stands. A little further, there is the edge of the mining field exploited with wall 97a at the depth of ca. 700 m, marked with a red line. In Figure 4, the area of this particular field was marked yellow and green. The church is located in a more or less central manner only in relation to the field exploited in the years 2011-2012 with wall 18a (at the depth of ca. 750 m).

For the purpose of observing the effects of mining activity upon the condition of the church building, on the 8th of December, 2011, the inclinometer described above was installed in tower 3, together with a telemetric wire meter TMS-1 (Kanciruk, 2004) and four dilatometers for observing changes of the width of the cracks in main aisle 1. The telemetric wire meter is a device built by

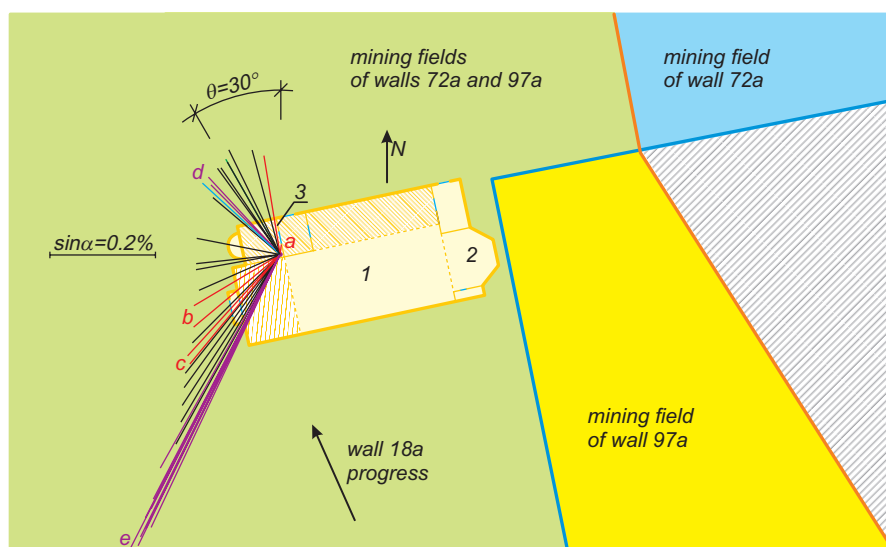

Fig. 4. Plan of the church; its situation in relation to mining fields; changes in the angular tilt of the tower.
1 – the main aisle, 2 – the presbytery, 3 – the tower

the Author of the present paper. Its function is to carry out automatic, multi-channel measurements of physical quantities, with the application of vibrating wire transducers, and to transmit the obtained data to a proper destination via a widely accessible mobile telephoning network. It was decided that a series of measurements would be carried out at the frequency of 8 attempts per day. In each series, vibration periods T of particular wires are measured four times, which makes it possible to evaluate the repeatability of the measurements and calculate the mean values of these periods. In this way, over 1,700 measurement results were obtained before the mid-July, 2012. For the clarity's sake, the figure depicts just the changes in the angular tilt of the tower as registered at weekly intervals, as well as changes caused by quakes recognized by human senses.

Just a day after the equipment was installed, a powerful quake occurred at a distance of ca. 200 m between the church and the working face. As a result of the quake, the tilt of the church tower deepened abruptly, from 0.02% to 0.19%, and angle θ changed from -6.8° to 9.3° . These changes are depicted by means of two sections "a" (the first of them being short and poorly visible), sketched with a red line. After the quake, with the tilt remaining more or less the same, angle θ increased successively, until it reached the value of ca. 90° in the first days of March, 2012. At that time, the working face was situated right below the church. The only instance when a slight reversal in change tendencies was observed concerns the case of "d", which is the situation from the beginning of February, 2012 – the "blue" segment is temporarily ahead of the two "purple" segments. On the 21st and the 28th of March two powerful quakes occurred, depicted as pairs of red segments "b" and "c". Both quakes resulted in a slight increase of the tilt and a surge in the value of angle θ . The quake from the 28th of May did not influence the condition of the church tower in any noticeable way. Since then, a constant increase in the tower tilt has been observed, at an almost constant value – ca. 150° – of angle θ ("purple" segments „e"). In mid-July, 2012, the tilt reached the value of ca. 0.65%.

Analyzing Figure 4, one might arrive at the conclusion that exploitation with wall *18a* in the years 2011-2012 activated some older excavations, already existing in the area. Just as the first quake from the 8th of December, 2011, had occurred, the church tower tilted unexpectedly, almost precisely in the direction of north – i.e., in a direction opposite to the approaching working face. After that quake, this direction had been changing successively to the west one (which was precipitated by two consecutive quakes), in the direction of old excavations, until it finally stabilized (four “purple” segments “e” in Fig. 4).

5. Summary

The procedure of the inclinometer calibration, as well as its practical implementation in the process of observing the tilt of a building caused by underground mining activity, prove that construction assumptions presented in Section 2 of the present paper have been fully justified. Suspending the pendulum on three measuring wires placed at 120° intervals makes it possible to construct a device with which one can determine not only the tilt of the investigated edifice, but also the angle between the plane of the tilt and the initially assumed direction. The high sensitivity of the device is due to lack of any other – apart from the wires – supporting elements for the pendulum. The way in which the measured quantities are determined eliminates the influence of temperature on the readings of the device. The application of simple elements made of widely used materials reduces the costs of the inclinometer’s construction. Although the prototypical inclinometer is a simple device, it served its purpose, registering the effects of the moving working face on the condition of the tower of a historical church, as well as the impact of older excavations and quakes on the edifice.

Some of the construction ideas should still be perfected, but this will certainly not change the basic parameters of the device. Suspending a heavy pendulum on three thin wires – regardless of the appliance of the locking mechanism – requires delicate handling, which might be regarded as a drawback of the proposed inclinometer.

References

- Crawford F.C., 1973. *Fale*. PWN Warszawa.
- Florkowska L., 2010. *Land subsidence due to mining operations in disturbed rock mass, on the example of Ruda Śląska (Poland)*. Arch. Min. Sci., Vol. 55, No 3, p. 691-701.
<http://www.funkstunde.com/de/technik/maihak.html>
<http://www.gage-technique.ae/VWextensometer.htm>
<http://www.geokon.com>
<http://www.geokon.com/products/datasheets/6300.pdf>
- Kanciruk A., 2004. *Telemetryczny miernik strunowy TMS-1*. Prace Instytutu Mechaniki Górniczej PAN. Tom 6, nr 1-2, Kraków.
- Kanciruk A., 2009. *Nowe przetworniki strunowe i ich zastosowanie*. Prace Instytutu Mechaniki Górniczej PAN. Tom 11, nr 1-4, Kraków.
- Polska aparatura strunowa PAS. Katalog*. Polmatik, Krajowy System Automatyki i Pomiarów.

Received: 04 January 2012