

# Overview of solutions used in rehabilitation devices using muscles and pneumatic actuators

Marta Żyłka<sup>a\*</sup>, Wojciech Żyłka<sup>b</sup>

<sup>a</sup> Rzeszów University of Technology, The Faculty of Mechanical Engineering and Aeronautics, Department of Aerospace Engineering, al. Powstańców Warszawy 12, 35-959 Rzeszów, Poland

<sup>b</sup> University of Rzeszów, College of Natural Sciences, The Didactic Centre of Technical and Natural Sciences, al. Rejtana 16c, 35-959 Rzeszów, Poland

## Article history

Received: 8 February 2021

Received in revised form:  
18 February 2021

Accepted: 20 February 2021

Available: 21 February 2021

## Abstract

The article presents selected rehabilitation devices with the use of classic actuators and pneumatic muscles. Manipulators supporting the movements of the lower and upper limbs of humans are presented. Moreover, the construction of actuators and pneumatic muscles is described.

**Keywords:** pneumatic actuators, pneumatic muscles, rehabilitation devices

## Introduction

An important issue in research and experiments as well as in rehabilitation practice is the use of pneumatics in supporting movement exercises of human limbs. Rehabilitation robots and manipulators help sick people in rehabilitation exercises and in performing basic everyday activities, e.g. moving objects. Awareness of the improvement of the living standards of the society leads to the construction of more and more new rehabilitation devices allowing the improvement of the quality of life of people with disabilities. The modern research on pneumatic manipulators is very satisfactory. Outside of Poland, scientists are constructing new devices, increasing the amount of research and the number of patients, looking for the best technical solutions and the best exercise algorithms. In Poland, the discussed issue is of great interest, e.g. methods and concepts of design solutions for devices for diagnosing hand functions in the rehabilitation process were developed. There are modern designs of rehabilitation devices that use muscles and pneumatic actuators in their operation.

## Pneumatic muscles

It is fascinating how perfectly natural muscles work during a full contraction. It is therefore a particular challenge to implement the type of contraction provided by pneumatic muscles.

Fig. 1 shows a picture of a pneumatic muscle. Compared to classic pneumatic actuators, pneumatic muscles are characterized by: lower costs, lower weight, higher forces in relation to weight [1]. Due to the above-mentioned advantages, pneumatic muscles can be used in rehabilitation robots [4].

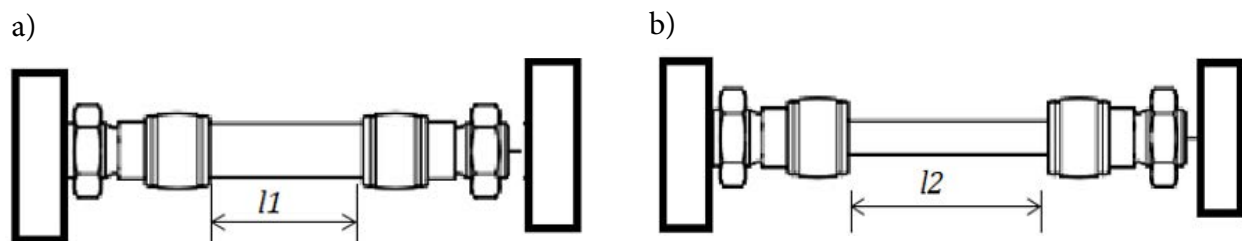

**Figure 1.** MAS pneumatic muscle [17].

Pneumatic muscle actuators differ to some extent from traditional pneumatic actuators. They are used as driving elements for mobile, anthropomorphic, bionic and humanoid robots or rehabilitation manipulators [13]. The construction of the muscle is very simple. The pneumatic muscle consists of two layers: inner and outer. The inner layer is made of rubber, while the outer layer is made of interwoven nylon fibers, which constitute a flexible structure with high tensile strength [3].

Fig. 2 shows a diagram of a pneumatic muscle. Fig. 2a) shows a muscle which contracts under the influence of pressure, i.e. its length decreases. On the other hand, fig. 2b) shows a muscle strained by an external force.

\*Corresponding author: mzyylka@prz.edu.pl



**Figure 2.** Diagram of a pneumatic muscle a) muscle contraction, b) muscle elongation (based on [19]).

With increasing air pressure, the circumference of the muscle increases and its length decreases, causing contraction [13].

Tractive force is at its maximum at the beginning of contraction and decreases almost linearly with stroke. With the help of a muscle, it is possible to obtain a working stroke within 25% of the nominal length of the muscle [17].

### Pneumatic actuators

Pneumatic actuators (Fig. 3) are elements that convert compressed air energy into mechanical energy.



**Figure 3.** KDNC pneumatic actuator [17]

Depending on the application, they can be divided into: piston, diaphragm, bellows, plunger, bag and tube. This division is presented in Fig. 4.

The design of a pneumatic actuator is much more complex than a pneumatic muscle. A typical piston air cylinder consists of a number of components as shown in Fig. 5.

### Manipulators and rehabilitation robots

In recent years, there has been a lot of interest in the subject of rehabilitation robots using pneumatic actuators in their work. Many centers adapt already existing robots to the requirements of rehabilitation. Others, in turn, try to create completely new devices.

The aim of the research is to help the therapist in his physical work and to reduce the costs of rehabilitation. Many robots, including service and industrial robots, have been developed to help people [5].

Work on the implementation of therapeutic robots to improve human limbs is constantly ongoing (PhysiotherapyRobot, Berkeley, Therapy Robot MiT-Manus, ARM Guide, VA Palo Alto HCS). Working with a therapeutic manipulator brings new experiences in the technique of motor improvement [6].

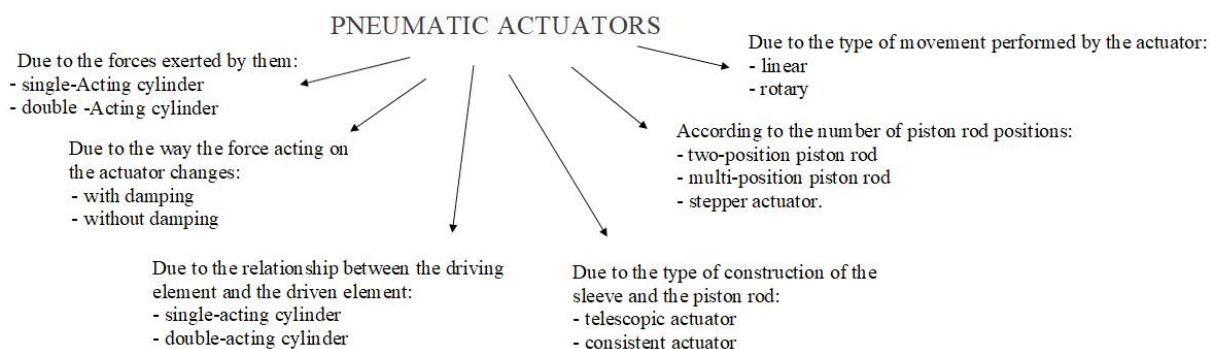

**Figure 4.** Classification of piston pneumatic actuators (based on [12]).

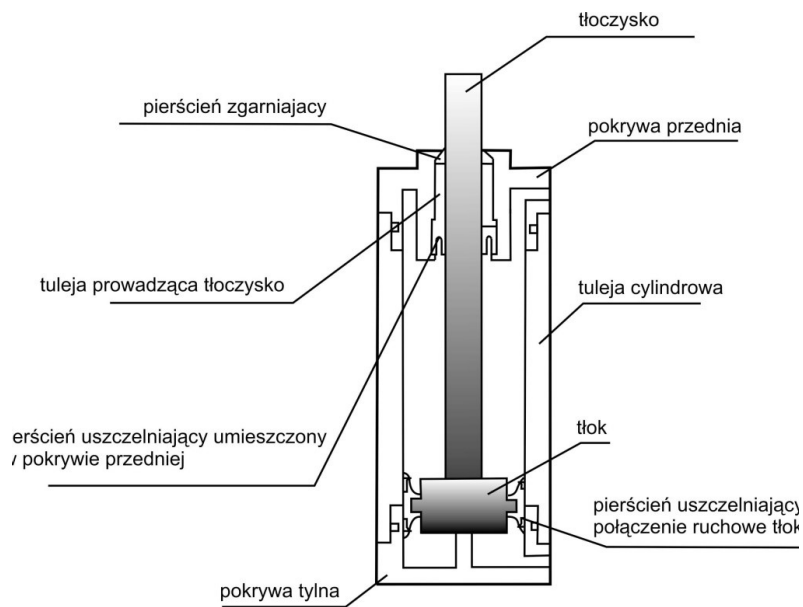

**Figure 5.** Diagram showing the basic parts of the pneumatic actuator (based on [12]).

Computer-programmed robots and therapeutic devices with the possibility of performing exercises in a virtual environment can be used by patients at home under the supervision of a doctor via the Internet. Telemedicine, or remote medicine, with the rapid development of multimedia technologies, enters the awareness of doctors and patients more and more boldly as a reality. Even today, in many regions of the

world, it is the only bridge between the patient and the doctor or physician and the center with the highest level of reference. An example of a device that uses telerehabilitation is the Rutgers Master II glove with pneumatic actuators shown in Fig. 6 [8]. The presented glove (Fig. 6) is adapted to the coupling with a computer equipped with software containing a set of virtual exercises [8].

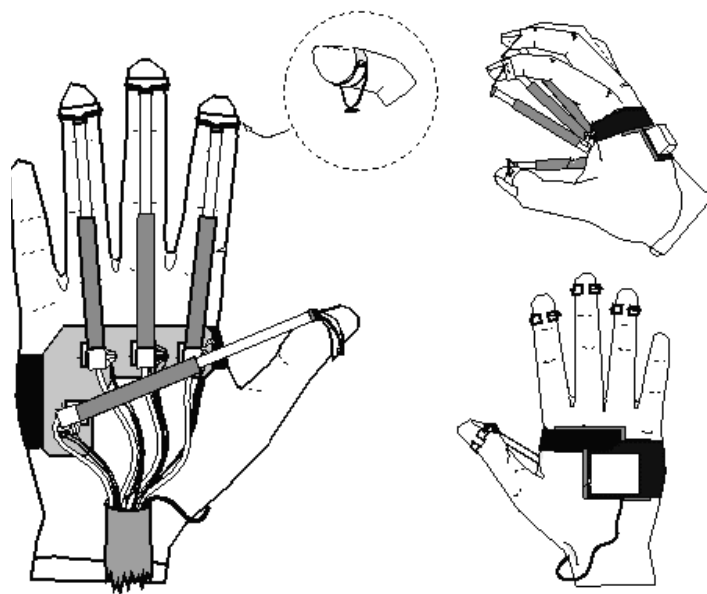

**Figure 6.** Rutgers Master II glove operation diagram [8].

## Hand mentor

The hand mentor is a device adapted to exercise the fingers and wrist joint, giving the patient the opportunity to exercise the hand independently. The Hand Mentor device is shown in Fig. 7. By using sensors, the patient constantly tracks the progress and course of the exercise on a small display. Traditional robotic drives (electric motors) in this device have been replaced by pneumatic muscles that mimic human muscles. The pneumatics used is cheaper than electronics, but it is more difficult to control. The device has five degrees of freedom. It is designed so that it can be worn on the hand like a bracelet [10].



**Figure 7.** Hand Mentor – a device helping to increase manual skills of the hand [15].



**Figure 8.** Upper limb rehabilitation manipulator exoskeleton - Rupert II (left) and Rupert III (right) [7].

**RUPERT I and RUPERT II** (Robotic Upper Extremity Repetitive Therapy). The device was built with the participation of Arizona State University (Jiping He) and Kinetic Muscles [7]. The exoskeleton of the upper limb rehabilitation manipulator – Rupert II and Rupert III is presented in Fig. 8.

The manipulator is powered by four pneumatic muscles, which force the movement of the shoulder, elbow and metacarpophalangeal joints. Thanks to the adjustment, it is possible to adapt it to different limb lengths. The device significantly speeds up the rehabilitation of patients and is suitable for rehabilitation at home [7].

## Automated gait trainer

The gait trainer shown (Figure 9) is intended for stroke survivors to reduce disability in the ankle function. Such a solution may be

helpful in rehabilitation with traumatic injuries during sports [2]. The device is a robot in which two pneumatic muscles work simultaneously, forcing the foot to move. When the pressure in the elastic duct of the muscle is increased, the muscles expand and, at the same time, shorten – the foot flexes. After the pressure is released, the muscle returns to its size – straightening the foot. The advantage of the device is that it can be adjusted to different limb lengths [2].

## Automated foot rehabilitation device

The ankle rehabilitation device is shown in Fig. 10. It is a device that uses soft plastics and composites instead of a rigid external skeleton. Soft materials are combined with artificial pneumatic muscles (PAMs) and lightweight sensors. Advanced control

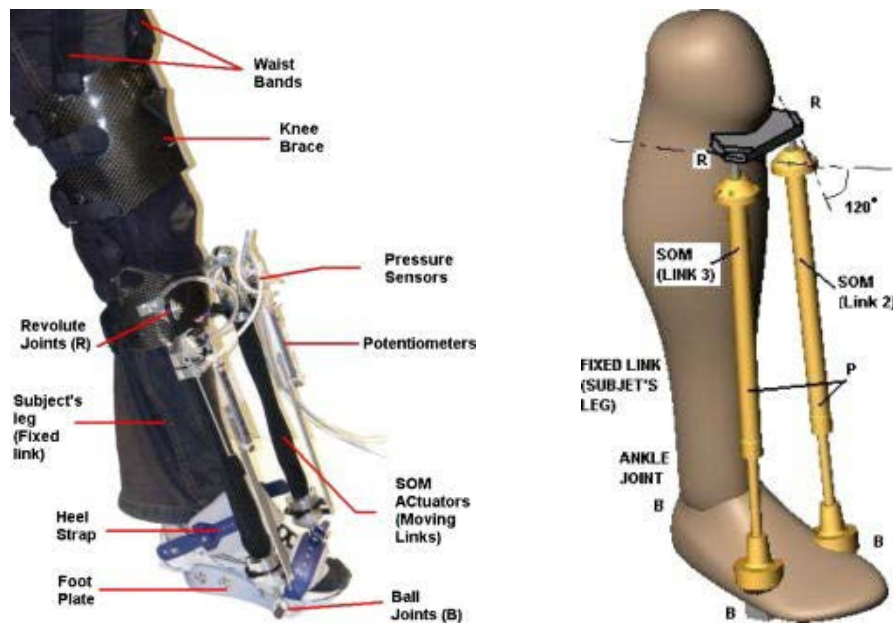

Figure 9. Automated gait trainer (X-ray) [2]

software enables natural ankle movements. The automated device is suitable for people with foot and ankle muscular disorders related to cerebral palsy, multiple sclerosis, and traumatic injuries

during sports. This design approach will be helpful to create devices for other parts of the body or to create a flaccid external skeleton that would increase the strength of the wearer [16].

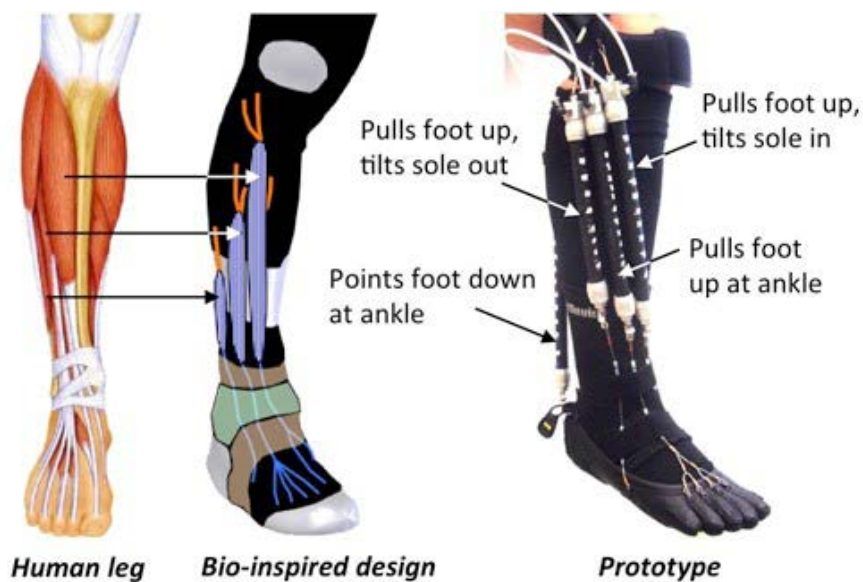

Figure 10. Foot rehabilitation robot [16].

Four pneumatic muscles are attached to the artificial tendons. Three muscles work in front of the lower limb, while the fourth is attached to the back of the leg to control the movement of the ankle joint. The caoutchouc rubber contains long, narrow microchannels that are filled with a liquid metal alloy. While the caoutchouc rubber stretches, the microchannel shapes change the electrical resistance of the alloy. These sensors were placed at the side of the ankle [16].

### Examples of rehabilitation devices with pneumatic actuators

#### *iPAM – an intelligent pneumatic device for exercising the upper limb*

iPAM was created thanks to the cooperation with, among others, University of Leeds, University of Manchester NHS and NEAT (Fig. 11). It consists of two robots connected to the patient with a shoulder brace and a forearm brace. The robots guide the hand along a given trajectory, imitating the work of a rehabilitator. This relieves the rehabilitator, who becomes needed only in more complex exercises and checking the work of robots [9].

The presented system shows the patient the correctness of the movements performed and monitors the patient's progress. The attractiveness of performed exercises is increased through the use of constantly refined and improved virtual reality [9].

#### *Wilmington exoskeleton*

WRE (Wilmington Robotic Exoskeleton) is shown in Fig. 12. The Pneu-Wrex exoskeleton has five degrees of freedom. Its main purpose is to help with everyday activities (e.g. eating). It is also adapted to rehabilitation at home, and the interaction with the virtual environment (tasks to be performed by the patient are

displayed on the computer monitor) makes rehabilitation easier and more interesting. It is suitable both for exercises with children and the elderly after stroke. Pneumatic actuators are used for the drive. It enables a wide range of movements of the upper limb and the measurement of hand strength. The presented device is able to act with the following forces: 45 N (along the x axis – to the right of the patient's body), 55 N (along the y axis – in front of the patient) and 70 N (along the z axis – upwards) [11].



Figure 11. iPAM (Intelligent Pneumatic Arm Movement) [9].

#### *Folded actuators in pneumatic massages*

Folded actuators, in most rehabilitation offices, help in the treatment of patients with venous and lymphatic insufficiency.

To perform pneumatic massages, special cuffs and pneumatic sleeves are used (they can be one, three, five and ten-chamber). Fig. 13 shows an example of such an air cuff. The principle of operation of the pneumatic massage consists in alternately inflating air into specially constructed cuffs (for the limbs) and releasing it in appropriate time proportions. Different therapeutic effects are obtained by changing the sequence, cycles and degree of inflation of individual chambers of the cuffs [14].

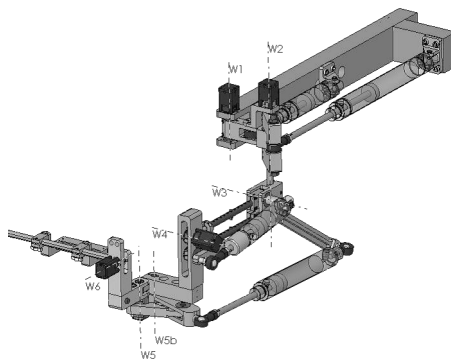

Figure 12. Pneu – WRE (Wilmington Robotic Exoskeleton) [11].





**Figure 13.** 12-chamber system for the non-invasive treatment of cardiovascular and lymphatic diseases – Flowtron hydroven 12 [14].

## Results and Discussion

The use of pneumatics is becoming more and more noticeable in the field of medicine. The use of pneumatics in the field of rehabilitation can make it easier for patients to cope with various diseases and help raise the level of everyday functioning.

Designing rehabilitation devices is a long and very complex process. It requires the cooperation of specialists from various fields (including engineers, physiotherapists, doctors). It consists of a driving, control and visualization part. The work of a physiotherapist is mostly dedicated to one patient, and additionally, it is long and tiring. The robot does not get tired, has a programmed set of exercises, leaving the therapist only to choose them and evaluate their progress. The safety of equipment operation is a very important element. Therefore, they are designed in accordance with technical, in particular medical, norms and standards.

## Author Contributions

Conceptualization, Marta Żyłka; methodology, Marta Żyłka; validation, Wojciech Żyłka; formal analysis, Marta Żyłka; writing—original draft preparation Marta Żyłka, Wojciech Żyłka; data curation Wojciech Żyłka; writing—review and editing, Marta Żyłka, Wojciech Żyłka; supervision, Wojciech Żyłka; project administration, Marta Żyłka; investigation, Wojciech Żyłka; resources, Wojciech Żyłka; acquisition, Marta Żyłka; visualization, Wojciech Żyłka, Marta Żyłka.

## References

1. Aschemann H, Schindele D. Comparison of model-based approaches to the compensation of hysteresis in the force characteristic of pneumatic muscles. *IEEE Transactions on Industrial Electronics*. 2014;61(7):3620–3629. doi: <https://doi.org/10.1109/TIE.2013.2287217>.
2. Bharadwaj K, Sugar T. Kinematics of a robotic gait trainer for stroke. In: *Proceedings 2006 IEEE International Conference on Robotics and Automation*, 2006. Orlando, FL: ICRA; 2006. p. 3492–3497. doi: <https://doi.org/10.1109/ROBOT.2006.1642235>.
3. Caldwell DG, Razak A, Goodwin MJ. Braided pneumatic muscle actuators. *IFAC Proceedings Volumes*. 1993;26(1):507–512. doi: [https://doi.org/10.1016/S1474-6670\(17\)49354-2](https://doi.org/10.1016/S1474-6670(17)49354-2).
4. Cao J, Xie SQ, Das R. MIMO sliding mode controller for gait exoskeleton driven by pneumatic muscles. *IEEE Transactions on Control Systems Technology*. 2018;26(1):274–281. doi: <https://doi.org/10.1109/TCST.2017.2654424>.
5. Choi TY, Lee JJ. Control of manipulator using pneumatic muscles for enhanced safety. *IEEE Transactions on Industrial Electronics*. 2010;57(8): 2815–2825. doi: <https://doi.org/10.1109/TIE.2009.2036632>.
6. Dindorf R. Rozwój zaopatrzenia ortopedycznego z elementami płynowymi. *Pomiary, Automatyka, Robotyka*. 2004;7(6): 4–9.
7. Sugar TG, et al. Design and control of RUPERT: a device for Robotic Upper Extremity Repetitive Therapy. *IEEE Transactions on Neural Systems and Rehabilitation Engineering*. 2007;15(3):336–346. doi: <https://doi.org/10.1109/TNSRE.2007.903903>.
8. Forducey P, Hentz V, Burdea G, Fensterheim D, Winter S, Kourtev H, Heuser A. Tele-rehabilitation using the Rutgers Master II glove following carpal tunnel release surgery. In: *2006 International Workshop on Virtual Rehabilitation*. New York, NY: IEEE; 2006. p. 88–93. <https://doi.org/10.1109/IWVR.2006.1707533>.
9. Holt R, et al. User involvement in developing rehabilitation robotic devices: an essential requirement. In: *2007 IEEE 10th International Conference on Rehabilitation*

- Robotics. Noordwijk: IEEE; 2007. p. 196-204. doi: <https://doi.org/10.1109/ICORR.2007.4428427>.
10. Sarakoglou I, Kousidou S, Tsagarakis NG, Caldwell DG. Exoskeleton-based exercisers for the disabilities of the upper arm and hand. In: Kommu SS, editor. *Rehabilitation Robotics*. Vienna: Itech Education and Publishing; 2007. p. 500–522. doi: <https://doi.org/10.5772/5177>.
  11. Sanchez RJ, et al. A pneumatic robot for re-training arm movement after stroke: rationale and mechanical design. In: 9th International Conference on Rehabilitation Robotics, 2005. ICORR 2005. Chicago: IEEE; 2005. p. 500–504. doi: <https://doi.org/10.1109/ICORR.2005.1501151>.
  12. Szenajch W. *Napęd i sterowanie pneumatyczne*. Warszawa: Wydawnictwa Naukowo-Techniczne; 1997.
  13. Takosoglu JE, Laski PA, Błasiak S, Bracha G, Pietrala D. Determining the static characteristics of pneumatic muscles. *Measurement and Control*. 2016;49(2):62–71. doi: <https://doi.org/10.1177/0020294016629176>.
  14. Company advertising materials Flowtron HYDROVEN – PPU Real Olsztyn.
  15. Hand rehabilitation system / computer-based Hand Mentor Kinetic Muscles. [Internet]. Available from: <https://health-management.org/products/view/hand-rehabilitation-system-computer-based-hand-mentor-kinetic-muscles>. Accessed 15 January 2021.
  16. Spice B. Press release: bio-inspired robotic device could aid ankle-foot rehabilitation, CMU researcher says. [Internet]. Available from: [https://www.cmu.edu/news/stories/archives/2014/january/jan20\\_anklefootrehab.html](https://www.cmu.edu/news/stories/archives/2014/january/jan20_anklefootrehab.html). Published 20 January 2014. Accessed 20 January 2021.
  17. EBMiA.pl Elementy Budowy Maszym i Automatyki. [website]. Available from: [www.ebmia.pl](http://www.ebmia.pl). Accessed 2 February 2021.
  18. Muskuł pneumatyczny MAS I DMSP. [Internet]. Available from: <https://www.automatyka.pl/produkty/muskul-pneumatyczny-mas-i-dmsp-7673-2>. Published 18 May 2006. Accessed 4 February 2021.
  19. Fluidic muscle DMSP. Festo; 2019. [Internet]. Available from: [https://www.festo.com/cat/pl\\_pl/data/doc\\_engb/PDF/EN/DMSP\\_EN.PDF](https://www.festo.com/cat/pl_pl/data/doc_engb/PDF/EN/DMSP_EN.PDF). Accessed 17 February 2021.