

Jana PERÁČKOVÁ, Veronika PODOBEKOVÁ
Slovak University of Technology in Bratislava, Slovakia

UTILIZATION OF HEAT FROM SEWAGE

The increase in fossil fuel prices and the negative environmental impacts of fossil fuel use force people to use renewable energy more widely. Recovery of waste heat also ranks among the renewable energy sources. It is proposed mainly in passive houses and energy-efficient buildings. Heat from wastewater can be optimally used for heating, cooling and hot water preparation in low-energy houses. Thermal energy can be extracted from the drain outside the housing and also in the building. For heating or cooling systems in buildings sources of wastewater with higher flow, for example the administrative buildings, the swimming pools or industrial production are suitable. For preheating domestic hot water locally regenerative systems inside buildings can be used.

Keywords: heat exchanger, heat recovery, wastewater, sewage pipes

INTRODUCTION

Heat recovery is classified as renewable energy source. Heat recovered from wastewater can be optimally used in low-energy buildings for low temperature heating, high temperature cooling and also to preheat domestic hot water. Thermal energy can be extracted from the sewage outside the building, and also inside the building. Wastewater sources with higher flow are suitable for heating or cooling in buildings, such as for example multiple family dwellings, groups of residential buildings, communal buildings, hotels, swimming pools, thermal baths and industry. Locally regenerative systems inside buildings can be used to preheat domestic hot water. The main elements of the external wastewater heat recovery system are heat exchanger and heat pump. Heat recovery systems inside buildings consist of heat exchanger built into the sewage pipe and connected to the mixer tap or the storage reservoir.

1. GENERAL CONDITIONS FOR DESIGN OF HEAT EXCHANGERS

Design of heat exchangers depends on the different requirements and the suitability of the sewage system. In the design of heat recovery systems of sewage different boundary conditions outside or inside the building are set. The following factors are critical for the design and application of heat recovery systems:

- short distance between the consuming system and the place of heat recovery,
- temperature of the wastewater constant, as possible,
- flow of wastewater,
- diameter of sewage pipe,
- sufficient pressure conditions in pipes,
- flow rate of wastewater in the pipe should be as high as possible (at least 1.0 m/s), in order not to create sediments (biofilm) [4].

2. TYPES OF HEAT EXCHANGERS

Disposition and design of heat exchangers is based on various requirements and the suitability of the sewage network itself. Design of heat exchangers depends on different requirements and on suitability of sewage system itself. Heat exchangers can be installed into existing or new pipelines. It can be used for all kinds of waste water.

Heat exchangers (outside the building) are classified according to the structure and location of the:

- heat exchangers embedded in sewage pipe,
- heat exchanger integrated in concrete wall of a sewage pipe,
- sewage pipe with special double jacket,
- double-pipe heat exchanger.

Heat exchangers used for heat recovery from sewage in the building have different design solutions. They are divided into following types, by design:

- double jacket copper heat exchanger to the downpipe,
- shower tray with integrated heat exchanger,
- regenerative panels with stainless steel heat exchanger.

3. HEAT EXCHANGERS IN THE SEWAGE OUTSIDE THE BUILDINGS

Heat recovery from large-diameter horizontal sewage pipes or from pressure sewage pipes embedded in the ground is proposed in the case, if there is ensured continuous flow of waste water [1].

Heat exchangers embedded in sewage pipe

Exchanger can be installed in both new and existing pipelines. It can be installed at the bottom of the pipe (Fig. 1) or at the upper edge. The heat from the waste water is discharged and passed through a heat exchange surface of heat exchanger. Under the heat exchanger are located distributing pipes (supply, return and bypass) which provide transmission of heat to the heat pump. Circuit layout of heat exchangers embedded in sewage pipe is plotted in Figure 2.

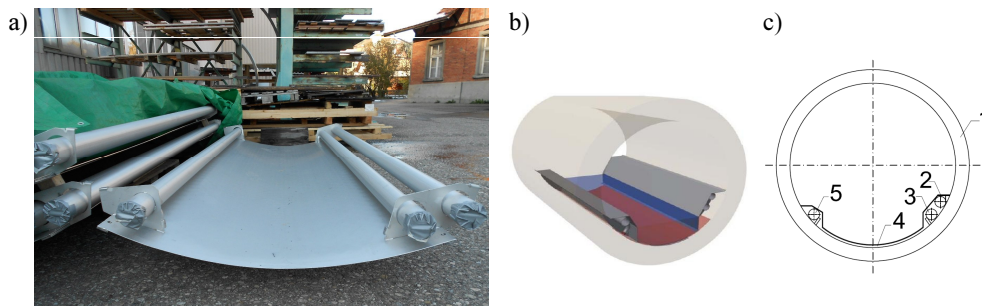

Fig. 1. Stainless steel heat exchanger placed in the bottom of the sewage pipeline: a) prior to installation, b) heat exchanger in sewage pipe, c) cross-section of heat exchanger; 1 - sewage pipeline, 2 - cold water supply to the heat exchanger, 3 - supply, 4 - heat exchanger, 5 - output of the heated water from the heat exchanger [4]

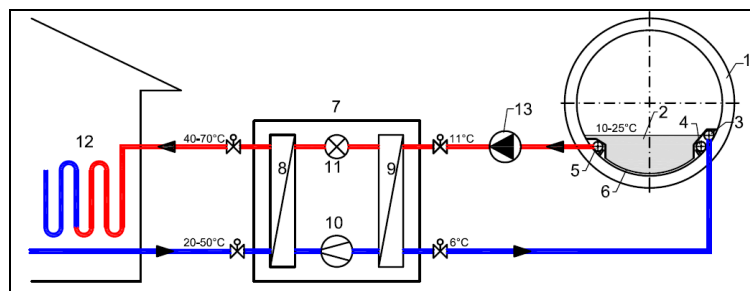

Fig. 2. Circuit layout of heat exchanger embedded in sewage pipe: 1 - sewage pipeline, 2 - waste water, 3 - cold water supply to the heat exchanger, 4 - supply, 5 - output of the heated water from the heat exchanger, 6 - heat exchanger, 7 - heat pump, 8 - condenser, 9 - evaporator, 10 - air pump, 11 - expansion valve, 12 - heating network in building, 13 - circulating pump

Heat exchanger integrated in concrete wall of a sewage pipe

The integrated heat exchangers can be used for the newly laid pipelines. The advantage is the quick installation and heat exchanger does not detract from the diameter of pipe. The disadvantage is poor accessibility for inspection and review (Fig. 3).



Fig. 3. Heat exchanger integrated in concrete sewage pipe: a) heat exchanger before installation, b) cross-section of heat exchanger; 1 - concrete pipe, 2 - cold water supply to the heat exchanger, 3 - bypass, 4 - heat exchanger, 5 - output of the heated water from the heat exchanger [5]

Sewage pipe with special double jacket

The whole circumference of sewage pipe is heat transfer surface. This surface transmits heat to distribution pipe installed in thermal insulation (Fig. 4). Sewer pipe with special double jacket can be used just as newly laid pipeline or for replacement of old sewage pipeline. It is suitable for gravity systems and pressure systems. For gravity systems, supply and return pipelines are located on the side of a steel sewage pipe. The heat transfer depends on the flow rate (level of waste water) in pipe (Fig. 4c). For pressure pipe distribution systems are located at the upper edge of the sewage pipe (Fig. 4b).

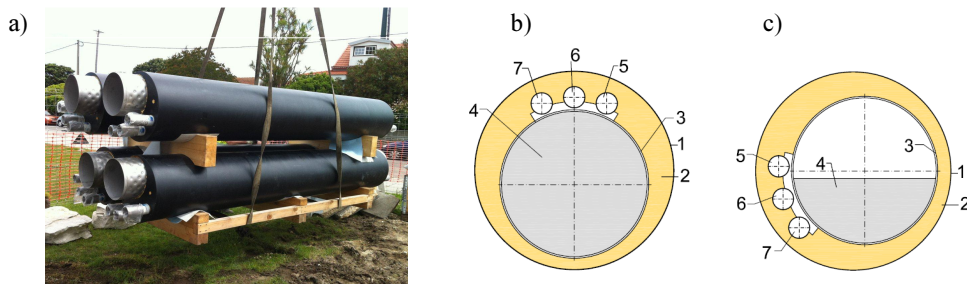

Fig. 4. Sewage pipe with special double jacket: a) prior to installation, b) pressure system, c) gravity system; 1 - outer jacket from polyethylene, 2 - heat insulation, 3 - sewage pipeline (heat exchanger), 4 - waste water, 5 - cold water supply to the heat exchanger, 6 - supply, 7 - output of the heated water from the heat exchanger [4]

Double-pipe heat exchanger

The heat exchanger consists of two pipes embedded in each other (Fig. 5). The waste water flows through internal pipe, where it is used as a heat source. Between inner and outer pipe is interspace, where flows clean water. Surface of internal pipe transfers heat from wastewater to clean water. Double pipe heat exchanger offers many advantages over conventional pipelines in connection with entrained solids in the wastewater. Such a system is suitable for gray and black water. The heat exchanger is not integrated directly into the sewage pipe system. Wastewater is pumped to the heat exchanger without screening or it can be pumped through collection tank to the heat exchanger.

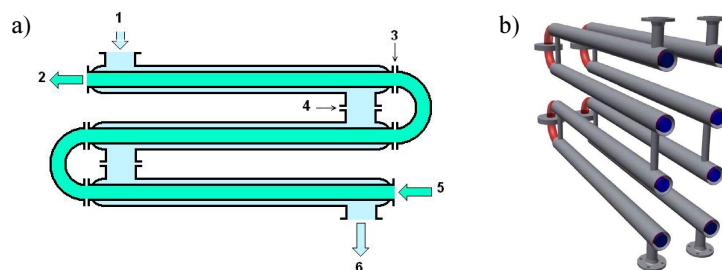

Fig. 5. Double-pipe heat exchanger: a) schema of heat exchanger [6], b) cross-section of heat exchanger [4]; 1 - cold water supply to the heat exchanger, 2 - waste water, 3, 4 - flange, 5 - waste water supply, 6 - output of the heated water from the heat exchanger

4. HEAT RECOVERY FROM SEWAGE INSIDE THE BUILDING

Buildings, where there is a constant flow rate of waste water and significant amount of it is being drained away, e.g. in hospitals, industrial buildings, swimming pools etc., are suitable for heat recovery directly inside them [1]. In this case, it is very convenient to use the heat from the sewage for preheating hot water for immediate consumption or in combination with a collection tank.

Double jacket copper heat exchanger to the downpipe

Heat exchanger with double jacket from copper can be installed to the downpipe for utilization of heat from waste water. The inner jacket is pipe from plain copper tube that drains waste water. The outer shell consists of copper tubing coil wrapped around the inner pipe (Fig. 6a) or it consists of another smooth copper pipe. In the outer coat flows cold water into mixer tap. Wall of downpipe is a heat transfer surface, which transfers the heat to flowing cold water, thereby ensuring a supply of preheated cold water to the mixer tap (Fig. 6b). The most advantageous is installed heat exchanger to downpipe directly below the sanitary equipment (e.g. shower) in the heated room. This type of heat exchanger is not suitable under sinks or kitchen sinks, because from them often flows wastewater with oil, which can settle on the wall of the heat exchanger and thus reduce its effectiveness.

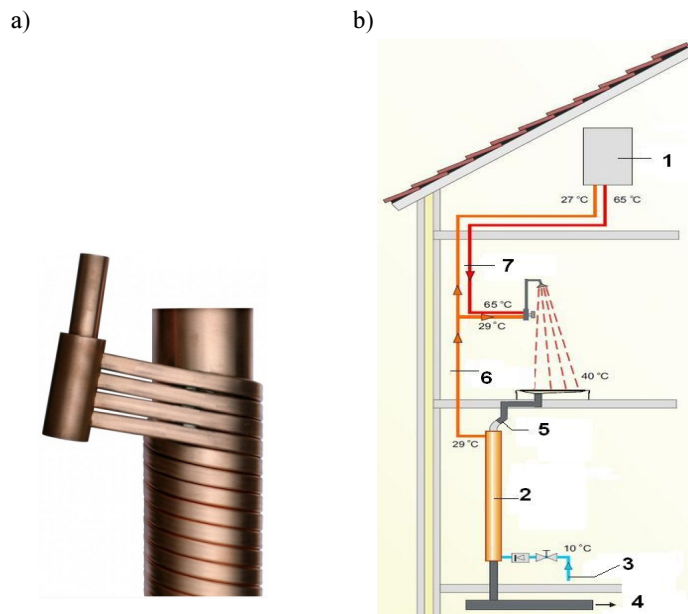

Fig. 6. Double jacket copper heat exchanger to the downpipe: a) detail of heat exchanger [7], b) circuit layout of heat exchanger [8]; 1 - storage water heater, 2 - double jacket copper downpipe (heat exchanger), 3 - cold water supply, 4 - cooled waste water, 5 - rotating drain of waste water, 6 - preheated cold water, 7 - hot water supply

Shower tray with integrated exchanger

In this case, the recuperation system consists of a special shower tray below which heat exchanger is integrated (Fig. 7). The system is designed for maintaining a normal height of shower tray and providing maximum performance of heat exchanger. Wastewater flows into the rounded copper plate. Under the copper plate is mounted the copper exchanger in a spiral shape (length 20 m). Cold water that flows into the heat exchanger is preheated by effluent hot waste water that flows around heat exchanger. Heat exchanger contains less than 1 l of water; therefore it is able to preheat cold water in a very short time. This kind of heat exchangers is recommended to be installed in houses, swimming pools, gyms, toilets, etc.

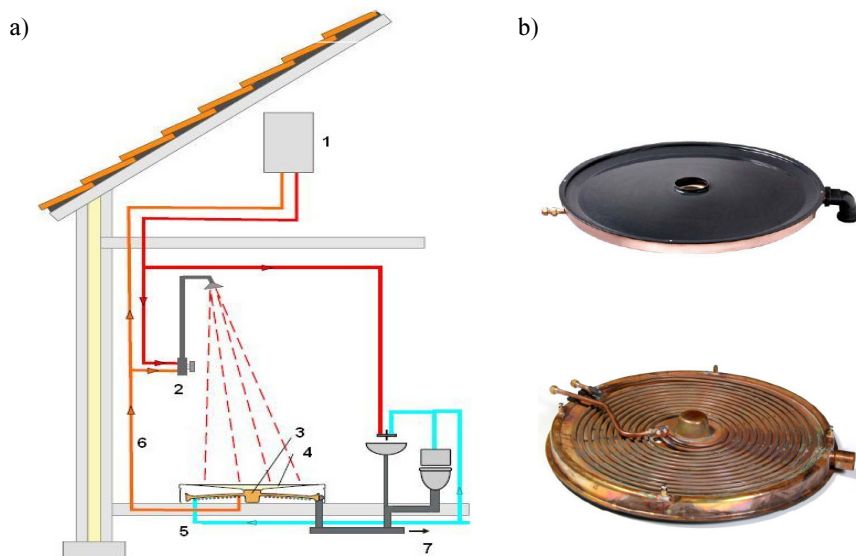

Fig. 7. Shower tray with integrated heat exchanger: a) circuit layout, b) heat exchanger, c) heat exchange coil inside of heat exchanger; 1 - storage water heater, 2 - mixer tap, 3 - drain, 4 - shower tray with heat exchanger, 5 - cold water supply, 6 - preheated cold water, 7 - cooled wastewater [8]

Regenerative panels with stainless steel heat exchanger

Regenerative panel consists of a plastic waterproof case and a stainless steel heat exchanger (Fig. 8). The heat exchanger is placed on connecting pipe or downpipe as close as possible to sanitary equipments (sinks, showers). Wastewater effluent from sanitary equipment flows around the heat exchanger in a plastic case. Through the heat exchanger to sanitary equipment is fed cold water ($5\div 10^{\circ}\text{C}$). Heat from wastewater is extracted and transferred by transfer area of heat exchanger to cold water. Temperature of the cold water can be increased up to 24°C in this way. Preheated water enters the mixer tap or storage water heaters so that the energy consumption of hot water is reduced which is currently used for showering or hand washing (Fig. 9) [9].

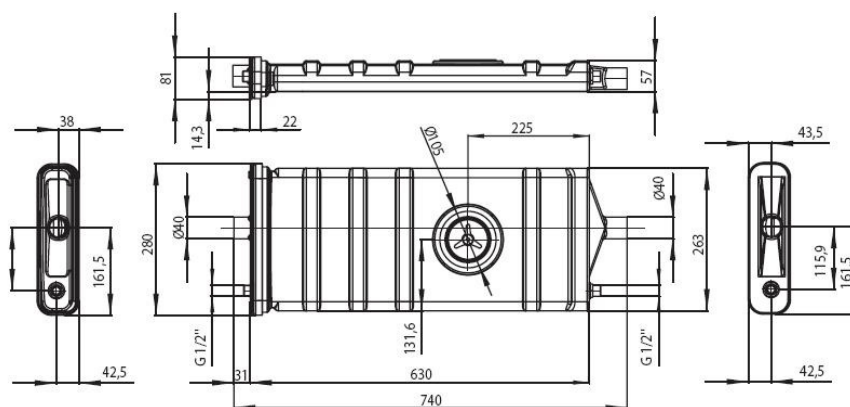

Fig. 8. Regenerative panels with stainless steel heat exchanger [9]

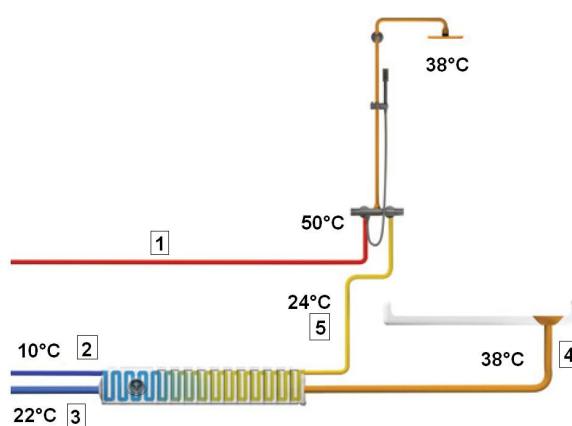

Fig. 9. Cold water preheated for immediate consumption through regenerative panel [9]: 1 - hot water supply, 2 - cold water supply, 3 - cooled wastewater, 4 - wastewater, 5 - preheated cold water

CONCLUSION

Heat recovery from waste water in buildings is not widely used in our country. The object of the research is to verify the possibility of using heat from sewers outside and inside the buildings in our country. The methodology of research will be simulation of energy flows in different recovery system and experimental measurement of small heat exchanger systems for preheating of hot water in the building. In Slovakia only small home regenerative systems for preheating of domestic hot water are nowadays being implemented. Large regenerative systems usable for heating and cooling are not yet implemented in our country. For substantial savings and other benefits that these systems offer, it would be most effective to apply them in Slovakia.

Acknowledgements

The contribution is part of a research project VEGA 1/0511/11.

REFERENCES

Literature:

- [1] Peráčková J., Spätne získavanie tepelnej energie z kanalizačných systémov, TZB Haustechnik 2009, 17, 7, 40-42.
- [2] Heizen und Kühlen mit Abwasser. Institut Energie in Infrastrukturanlagen Bundesverband Wärmepumpe (BWP) e.V., München 2005.
- [3] Müller E.A., Schmid F., Heizen und Kühlen mit Abwasser - Ratgeber für Bauherrschaften und Gemeinden, Bundesamt für Energie Schweiz, Bern 2005.

Documents from the companies:

- [4] KASAG LANGNAU AG
<http://www.kasag.ch/RENEWABLEENERGY/tabid/150/language/en-US/Default.aspx>
- [5] Rabtherm energy systems
http://www.rabtherm.ch/index.php?option=com_content&view=article&id=60&Itemid=35&lang=en
- [6] Wikimedia commons
http://commons.wikimedia.org/wiki/File:Double-Pipe_Heat_Exchanger.png
- [7] Power Pipe
http://www.renewability.com/power_pipe/index.html
- [8] HI-TECH
<http://www.hei-tech.nl/en/recoh-vert.html>
- [9] IVAR.CS
<http://www.ivarcs.cz/cz/rekuperace-odpadni-teple-vody-ivar-bee>
- [10] Klinger und Partner DE
<http://www.klinger-partner.de/uw/abwasserwaerme.php>
- [11] JC Equipments Pvt Ltd
<http://www.jcequipments.com/double-pipe-heat-exchanger.html>

WYKORZYSTANIE CIEPŁA Z KANALIZACJI

Wzrost cen paliw kopalnych oraz negatywne oddziaływanie na środowisko związane z ich użytkowaniem skłania ludzi do szerszego stosowania źródeł odnawialnych. Odzysk ciepła odpadowego również zalicza się do odnawialnych źródeł energii. Rozwiązania takie proponuje się głównie w domach energooszczędnych i pasywnych. Ciepło odzyskane ze ścieków może być wykorzystywane do ogrzewania, przygotowania ciepłej wody czy chłodzenia. Ciepło ze ścieków można odzyskać w budynkach, ale też poza nimi. Do ogrzewania lub chłodzenia w budynkach bardziej odpowiednie są źródła ścieków o wyższym przepływie, np. z budynków administracyjnych, basenów czy przemysłowych. Do przygotowania ciepłej wody użytkowej mogą być użyte lokalne systemy odzysku wewnątrz budynków.

Słowa kluczowe: wymiennik ciepła, rekuperacja, woda odpadowa, kanalizacja