

## DIMENSIONAL SYNTHESIS OF ACTIVE SUSPENSION CAB MECHANISM LINKS

Damian Brewczyński, Grzegorz Tora

Cracow University of Technology  
Institute of Machine Design  
Jana Pawła II Av. 37, 31-864 Krakow, Poland  
tel.: +48 12 6283408, fax: +48 12 3743360  
e-mail: brewczyn@mech.pk.edu.pl, tora@mech.pk.edu.pl

### Abstract

One of the directions of the heavy duty machine is the operator cabin construction, which provides a high level of comfort. Adequate control of active suspension drives can reduce low frequency and large amplitude vibrations occurring in a number of cabin degrees of freedom. The main link of the mechanism is the platform with cab suspended on two rockers and one actuator. Article proposes methods for determining the length of suspension arms, the width of the platform and centres of the joints, which are connected to the suspension. It has been proved for the flat case that if the momentary centre of rotation of the platform relative to the machine frame is located inside the road roughness zone is a single drive can effectively reduce transverse vibration and angle vibration around the longitudinal machine axis. Further conditions that determine links size are to prevent from peculiar positions, to avoid collision between cab wall and suspension joints. Presented relations between the height of the waist rough roads, wheelbase machine, cab mounting height on the machine and the dimensions of the link suspension mechanism. Presented dimensional calculation results cab suspension links dedicated to Caterpillar 924 GZ loader. Assuming the vertical driving cab calculated inaccuracy of its transverse displacements. Presented the results showing influence of the cab assembly height on the cabin mounting links dimensions.

**Keywords:** active vibration damping, platform mechanism, synthesis of the mechanism's dimensions

### 1. Introduction

The heavy-duty machine operator is exposed to long-term vibration, which may cause negative functional and physiological effects. Existing vibration in the operator workplace accelerates the tiredness, reduce the ability to concentrate, causing loss of productivity, and work quality. With many years of operator, exposure to vibration can lead to permanent changes in the musculoskeletal system, the cardiovascular, nervous and respiratory systems. Therefore, one of the directions of development of heavy duty machines is to reduce the vibration of the operator workplace.

The work of operators in heavy machinery requires constant attention to gather information about the machine's surroundings, its current status and the operations performed. Operators have to analyse the received information on the continuous basis and make decisions accordingly, to have them implemented via the control system and to perform the scheduled tasks in the optimal manner. The more powerful the machine, the more serious the consequence of errors committed by operators. The typical frequency range of vibration of machines and their implements systems is determined based on testing done on heavy machinery [1] and is found to be 0.5-80 Hz.

Active elements have appeared to support the existing vehicle suspension systems. It is demonstrated that the vibration reduction in vehicle suspensions is most effective in the low frequency range. Active suspension systems can supplement the passive and semi-active solutions, which effectively handle higher frequency vibrations. The good vibration reduction efficiency of active solutions, however, comes at a cost of high-energy demands. Active solutions typically use small-size hydraulic cylinders accelerating the masses subjected to high loads. The works [2, 3, 5] demonstrate the adequacy of active suspension solutions provided in cabs in vehicles moving in

rough terrain. Active vibration damping effects are achieved through altering some geometric parameters (coordinates of the attachment point of the suspension [4] or of a spring [6]). The work [9] explores the potential applications of a platform mechanism to vibration reduction in several DOFs.

In work [8] proposed an introduction to heavy-duty machine construction an active cab suspension. The effectiveness of such a system has been shown to suppress low-frequency vibrations of large amplitude for several movement directions of the cabin. This paper presents the method of determining the dimensions of links active cab suspension mechanism depending on terrain and height of the cabin on the machine. Assumptions were also adopted to avoid singular positions and collision links.

## 2. Actuator mechanism in the ASC

The active suspension mechanism, shown schematically in Fig. 1 has been engineered specifically for the purpose of modelling and simulations and its design involves a certain trade-off between functionality and simplicity.

The main function of the active suspension system is to stabilise the cab such that the correct control of the drives 1 and 4 should enable its vertical movement in the direction of the gravity force. The active suspension system comprises a platform  $p$  suspended on three limbs with spherical pairs having the centres  $B_1, B_2, B_3$ . The two limbs are rocker arms 2 and 3, connected to the machine frame  $r$  via a revolving pair. The third limb is the actuator 1 with the length  $s_1$ . The cylinder in the actuator  $1c$  is connected to the frame  $r$  via a cross pair with the point  $A_1$ . The piston in the actuator  $4t$  is connected to the rocker arm via a spherical joint with the point  $C_4$ . The length of the actuator 4 equals  $s_4$ . The part of the active suspension system comprising the rocker arms 2 and 3, an actuator and the platform  $p$  along the line segment  $B_2B_3$  can be treated as a planar mechanism where the points  $A_4, C_4, A_2, B_2$  and  $A_3$  are on the plane  $y_r z_r$  and the axes of joints  $A_2$  and  $A_3$  are parallel to  $x_r$ . The structure of the mechanism is such that the actuators 1 and 4, when in their middle position, do not carry the cab's gravity load and when in their extreme positions, the load due to the gravity force is carried mostly by the joints  $A_2, A_3$ . Besides, the performance of the mechanism is affected by manufacturing imprecision, though this influence is found to be negligible. The cab is rigidly attached to the platform  $p$ .

The presented ASC mechanism is capable of reducing the amplitudes of the cab's linear vibrations in the direction  $y_r$  and its angular vibrations around the axes  $x_r, y_r$ . The active suspension mechanism comprises just three passive links, set in motion by two linear drives. The separate seat suspension mechanism, driven by the cylinder 5, reduces the vibrations along the axis  $z_p$ .

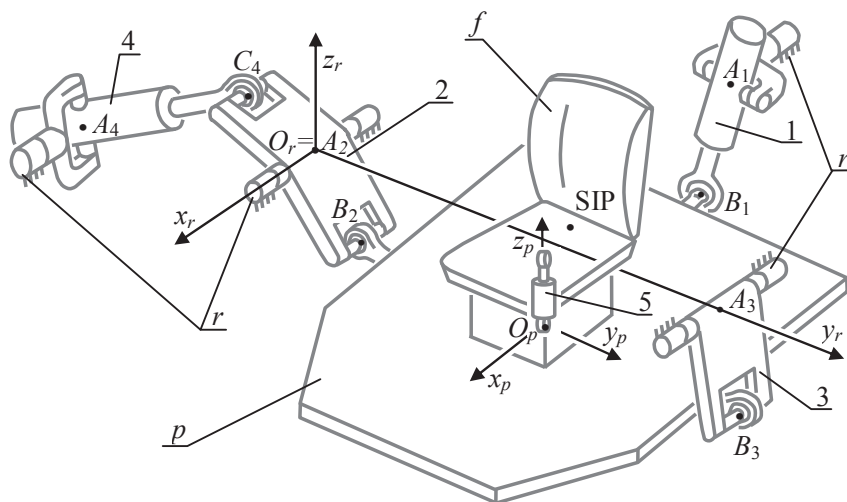

Fig. 1. Platform mechanism stabilising the cab in the vertical:  $r$  – machine frame,  $p$  – platform, 2, 3 – rocker arms, 1, 4, 5 – actuators

### 3. Reduction of the cab vibration in two DOFs with the use of a single drive

As explained in [7], application of a four-bar-linkage ( $A_2, B_2, B_3, A_3$ ) as a part of the active suspension mechanism enables the reduction of the cab's linear transverse vibration and its angular vibration around the longitudinal axis by means of a single drive 4 (Fig. 2).

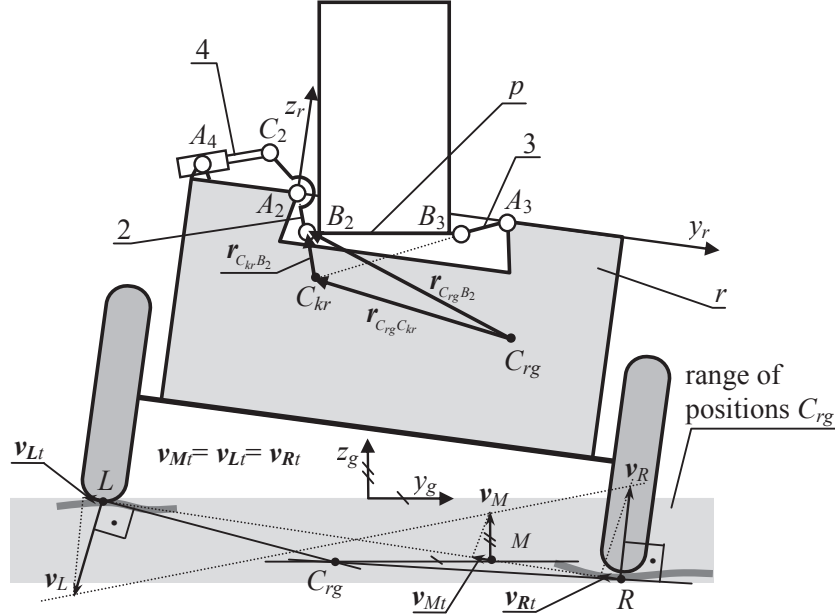

Fig. 2. Instantaneous centres of rotation

The purpose of the synthesis is to determine the dimensions of the four-bar-linkage ( $A_2, B_2, B_3, A_3$ ) such that the desired displacements of the platform and the cab should be executed, to make up for the displacements of the machine frame.

Let the instantaneous transverse plane  $y_r z_r$  of the machine be parallel to the plane  $y_g z_g$  of the system associated with the road. The instantaneous centre of the cab's rotation with respect to the machine frame  $C_k$  will be found at the intersection of straight lines determined by the points  $A_2 B_2$  and  $A_3 B_3$  (Fig. 3). Let the instantaneous point of the frame's rotation with respect to the road be located at the point  $C_{rg}$ . Velocity components of the point  $B_2$  on the plane  $y_r z_r$ , associated with the angular motion of the frame and the platform become:

$$V_{(B_2g)yz} = \omega_{(rg)x} \times r_{C_{rg}B_2} + \omega_{(kr)x} \times r_{C_k B_2}, \quad (1)$$

where:

$\omega_{(rg)x}$  – velocity component in the direction of the axis  $x_r$  of the frame's angular velocity with respect to the inertial reference systems  $\{O_g, x_g, y_g, z_g\}$ ,

$\omega_{(kr)x}$  – velocity component in the direction of the axis  $x_r$  of the cab's angular velocity with respect to the frame.

Substituting  $r_{C_{rg}B_2} = r_{C_{rg}C_{kr}} + r_{C_{kr}B_2}$  yields:

$$V_{(B_2g)yz} = \omega_{(rg)x} \times r_{C_{rg}C_{kr}} + (\omega_{(kr)x} + \omega_{(rg)x}) \times r_{C_{kr}B_2}. \quad (2)$$

In order that the angular velocity of the platform and of the cab in the direction of axis  $x_r$  should become zero, it is required that:

$$\omega_{(kg)x} = \omega_{(kr)x} + \omega_{(rg)x} = 0. \quad (3)$$

This requirement can be satisfied through the control of the cylinder 4 which regulates the velocity  $\omega_{(kr)x}$  adjusting it to match the measured parameter  $\omega_{(rg)x}$ .

Recalling (2) and (3), and  $r_{C_{rg}C_{kr}} = [0, r_y, r_y]^T$ , we get the coordinates of the velocity vector of the point  $B_2$ :  $v_{(B_2g)yz} = [0, -r_z \omega_{(rg)x}, r_y \omega_{(rg)x}]^T$ . The linear velocity component of the point  $B_2$  in the direction of the axis  $y_g$  can be set down to zero:  $r_z \omega_{(rg)x} = 0$ . This condition will be satisfied in two cases. In the first case the value of the angular velocity of the frame's motion with respect to the road equals zero  $\omega_{(rg)x} = 0$ . That happens when angular velocity has its sign changed, for instance when the frame is maximally tilted on one side. In the second case  $r_z = 0$ . This condition is satisfied when the instantaneous centre of the cab's rotation with respect to the frame and the instantaneous centre of the frame's rotation with respect to the road are positioned on the same level  $C_{(kr)z} = C_{(rg)z}$ .

The position of the instantaneous centre of the frame's rotation with respect to the road  $C_{rg}$  depends on the road profile during the ride of the machine. When the wheels run onto the road unevenness, the machine's inclination angle with respect to the axis  $y_g$  will vary. Let us consider a line segment  $LR$  of fixed length, equal to the wheel spacing. If there is a single point  $M$  on this line segment  $LR$  whose velocity in the plane  $y_g z_g$  has a vertical component only, then the horizontal line containing the point  $M$  must also contain the instantaneous centre of the frame's rotation  $C_{rg}$  with respect to the road. That corresponds to the conditions when the wheels do not slide with respect to the ground in the direction transverse to the machine ride.

Under those conditions, in any arbitrary position of the machine's frame, the potential field of occurrence of  $C_{rg}$  constitutes a horizontal band containing the road unevenness. The geometric representation of this situation is shown in Fig. 2.

#### 4. Relationships between the ASC links' dimensions

Assuming the midpoint position of the cab on the machine frame, the points  $A_2$  and  $A_3$  should be arranged symmetrically with respect to the frame's longitudinal axis and the lengths of the rocker arms 2 and 3 should be identical (Fig. 3)  $d_2 = d_3 = d$ . Basing on that observation and recalling the condition  $C_{(kr)z} = C_{(rg)z}$ , the links dimensions should be chosen such that the instantaneous centre of the platform's rotation with respect to the frame  $C_{rg}$  should be found in the horizontal range limited by  $R$  and  $L$  or as near to that range as possible.

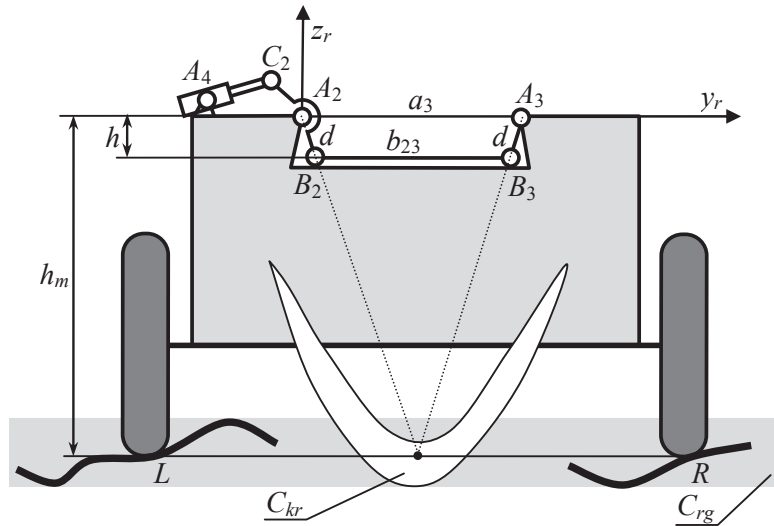

Fig. 3. Positions of  $C_{rg}$  and  $C_{kr}$

The horizontal belt-shaped area of occurrence of the instantaneous centre of the frame's rotation with respect to the road  $C_{rg}$  (enclosing the road unevenness) and the typical crescent-shaped area of occurrence of the instantaneous centre of the cab's rotation with respect to the frame  $C_{kr}$  are shown in Fig. 4. It is assumed that when the machine frame is in its horizontal position, the point

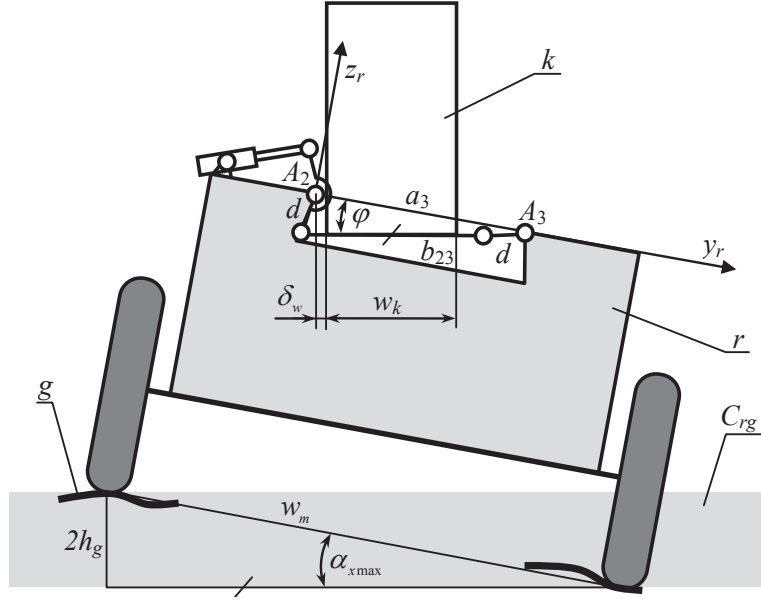

Fig. 4. Frame tilt angle with respect to the singular position of the suspension

$C_{rk}$  should be found on a contact line between the wheels and the ground. The distance between the points the rockers arm joints are attached to the frame  $A_2$  and  $A_3$  and the ground being  $h_m$ , then recalling the Pythagorean and Tales theorems, we get:

$$h_m \left( 1 - \frac{b_{23}}{a_3} \right) = \sqrt{d^2 - \left( \frac{a_3 - b_{23}}{2} \right)^2}. \quad (4)$$

Displacements of the four bar linkage in the ASC mechanism are constrained by the occurrence of singular positions. The mechanism should not come near the singular position, when controllability of the system deteriorates and the loads acting upon the drives and mobile connections tend to increase. For the predetermined maximal height of the road unevenness range  $2h_g$  and for the machine wheel spacing  $w_m$ , the maximal angle  $\alpha_{\max}$  of the machine tilting with respect to the axis  $y_g$  should be such that the four bar linkage should not assume a singular position (Fig. 4):

$$\alpha_{x\max} < \varphi \rightarrow \arcsin \frac{2h_g}{w_m} < \arccos \frac{a_3^2 + (b_{23} + d)^2 - d^2}{2a_3(b_{23} + d)}. \quad (5)$$

When the dimensions of links in the four bar linkage  $A_2 A_3 B_3 B_2$  as well as  $h_g$  satisfy the condition (5), the mechanism is able to operate in a single configuration.

Another geometric condition stems from the assumption that the cab can move freely without colliding with the joints  $A_2, A_3$ , when the machine assumes its extreme position due to tilting by the angle  $\alpha_{x\max}$  (Fig 4):

$$a_3 \cos \alpha_{x\max} > \frac{b_{23}}{2} + \frac{w_k}{2} + \delta_w + d, \quad (6)$$

where:

$w_k$  – cab width,  $w_k < b_{23}$ ,

$\delta_w$  – allowable distance between cab walls and the point of the joint  $A_2$  or  $A_3$ .

Satisfying the inequality (6) quarantines a fail-safe operation of the four bar linkage  $A_2 A_3 B_3 B_2$  and of the cab. Conditions (5), (6) yield the dimensions:  $a_3, b_2, d$ . When the machine is operated in uneven terrain where  $2h_g$  exceeds the predetermined value, the ASC mechanism can reach the limits of its working field and that is why the cab will momentarily deviate from the vertical direction.

## 5. Numerical results data of dimensions ASC selected links

Distance between the front and rear axle of the machine frame:  $l_m = 2.810$  m, wheel spacing:  $w_m = 2.060$  m, distance of joints in the rocker arm connections  $A_2$  and  $A_3$  from the ground:  $h_m = 2.420$  m, cab width:  $w_k = 1.200$  m, admissible distance between the cab's side wall from the joint axis  $A_2$  or  $A_3$ :  $\delta_w = 0.05$  m, height of the road unevenness for which the cab can be vertical:  $2h_{g \max} = 0.250$  m. Rocker arm's length 2 i 3:  $d_2 = d_3 = d = 0.227$  m, maximum angle of tilt around the longitudinal axis of the frame:  $\alpha_{x \max} \approx 0.122 \text{ rad} \approx 7.0^\circ$ , distance between the axles joints:  $A_2$  and  $A_3$ :  $a_3 = 1.636$  m, distance between the centres joints  $B_2$  i  $B_3$ :  $b_{23} = 1.490$  m,

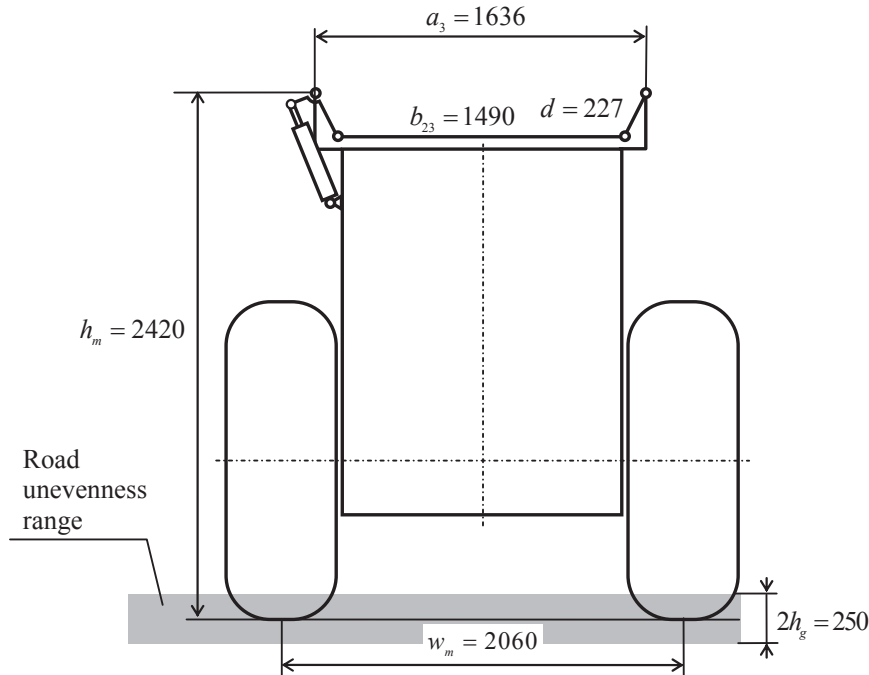

Fig. 5. Dimensions of ASC mechanism links [mm]

The control of the cylinder 4 can be effected assuming the vertical position of the cab, but it will be displaced in the transverse direction. The optimal performance of the suspension system can be achieved when the instantaneous centre of the cab's rotation with respect to the machine frame  $C_{kr}$  is found within the range of road unevenness (see Fig. 6). Diagram on Fig. 7 shows the dependence of main dimensions of the AZK mechanism links from height of the cab assembly on the machine.

## 6. Conclusions

It is demonstrated that when the instantaneous centre of the cab's rotation with respect to the machine frame is found on the same level as the instantaneous centre of the frame's rotation with respect to the road, then one cylinder suffices to reduce the amplitude of linear transverse vibrations of the cab base point and its angular vibration round the longitudinal axis.

The important parameter required for the synthesis of the links' dimensions is the maximal height of the road unevenness profile for which the frame is maximally tilted whilst the cab can still be stabilised in the vertical, the ASC mechanism occupying an extreme position. For smaller road unevenness, when the platform is found near its midpoint position, the suspension system performs very well. Its performance, however, tends to deteriorate when the road unevenness becomes considerable and the platform is approaching its extreme positions. The increase in the position height of the wishbones pivots connected to the active cab suspension increases the dimensions of the suspension mechanism links.



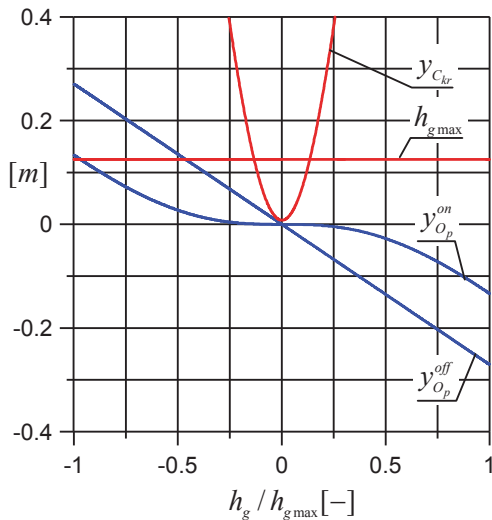

Fig. 6. Transverse displacement of the platform for the cab in its vertical position

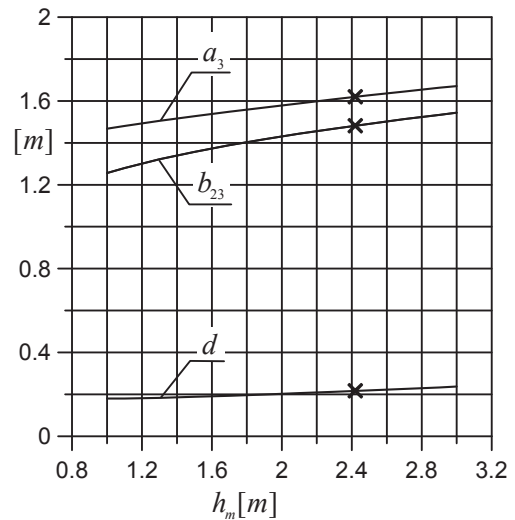

Fig. 7. Dependence of AZK links dimensions from cab mounting height

## References

- [1] Achen, A., Toscano, J., Marjoram, R., StClair, K., McMahon, B., Goelz, A., Shutto, S., *Semiactive Vehicle Cab Suspension Using Magnetorheological (MR) Technology*, Proc. of the 7th JFPS Int. Symp. on Fluid Power, TOYAMA, pp. 561-564, 2008.
- [3] Graf, Ch., Maas, J., Pflug, H.-Ch., *Concept for an Active Cabin Suspension*, Proceedings of the 2009 IEEE International Conference on Mechatronics, Malaga, Spain 2009.
- [4] Hannson, P.-A., *Control Algorithms for Active Cab Suspensions on Agricultural Tractors*, Vehicle System Dynamics, Vol. 25, pp. 431-461, 1996.
- [5] Jonasson, M., Roos, F., *Design and Evaluation of an Active Electromechanical Wheel Suspension System*, Mechatronics, Vol. 18, pp. 218-230, 2008.
- [6] Lofgren, B., *Active Cab Suspension*, Skog Forsk Resultat, Vol. 17, 1995.
- [7] Sampaio, J. V. R., *Design of a Low Power Active Truck Cab Suspension*, Eindhoven University of Technology, Department of Mech. Engineering, Dynamics and Control, 2009.
- [8] Tora, G., *Simulations of the Active Cab Suspension*, Journal of KONES Powertrain and Transport, Vol. 19, No. 1, pp. 453-464, 2012.
- [9] Yun, Y., Li, Y., *A General Dynamics and Control Model of a Class of Multi-DOF Manipulators for Active Vibration Control*, Mech. Mach. Theory doi:10.1016/j.mechmachtheory, 2011.04.010., 2011.

