



Volume 113

2021

p-ISSN: 0209-3324

e-ISSN: 2450-1549

DOI: <https://doi.org/10.20858/sjsutst.2021.113.16>



Journal homepage: <http://sjsutst.polsl.pl>

Article citation information:

Wheatley, G., Ali, A. Designing an upper stage steering system for a Formula FSAE car. *Scientific Journal of Silesian University of Technology. Series Transport*. 2021, **113**, 205-218. ISSN: 0209-3324. DOI: <https://doi.org/10.20858/sjsutst.2021.113.16>.

Greg WHEATLEY¹, Ahmed ALI²

DESIGNING AN UPPER STAGE STEERING SYSTEM FOR A FORMULA FSAE CAR

Summary. The objective of this work is to design an upper stage steering system for the Formula FSAE car “Omega” that will effectively translate driver input force to the rack and pinion. The system consists of a steering wheel, steering shafts, universal joints, a quick release mechanism, and connection points to the car. Critical loads have been determined, and the final design has been validated using finite element analysis to ensure the safety of the assembly during normal operation and worst-scenario cases. The design key factors were performance, weight, cost, ergonomics, maintainability, manufacturability and reliability.

Keywords: design, steering, race car

1. INTRODUCTION

Formula FSAE is a global student design competition whereby university teams design, build and compete with small, formula style vehicles exacting to FSAE design regulations and requirements. FSAE basic requirements dictate that the vehicle must be open-wheeled and open cockpit with four wheels that are not in a straight line and a wheelbase of at least 1,525 mm. Besides, the engine must be a four-stroke unit with a maximum of 610 cc/cycle.

¹ College of Science & Engineering, James Cook University, Townsville, Australia.
Email: greg.wheatley@jcu.edu.au. ORCID: <https://orcid.org/0000-0002-9115-9695>

² College of Engineering, King Saud University, Riyadh, Saudi Arabia. Email: jubara66@hotmail.com.
ORCID: <https://orcid.org/0000-0001-7490-4545>

The upper stage steering assembly is vital in ensuring the handling, performance and safety of the FSAE “Omega” design. For a driver to control the direction of travel, constant adjustment of the angle of the steering wheel is required. The driver does this based on a wealth of information, separate from the obvious visual indicators. Of these indicators, the most important information a driver receives comes from the steering torque, which provides direct, instantaneous feedback on forces acting at the wheels [1].

Steering systems must provide precision and “feel” to the driver such that the driver can sense the forces occurring at the tyre-road interface and must offer an instantaneous response to the driver input and have some self-returning action. There is a wide range of literature available on steering systems in modern day automobiles. For this review, such that only pertinent information is presented, the content will be restricted to factors directly affecting the upper stage steering assembly performance and design.

1.1. The steering axis (Kingpin)

In modern cars, two or more ball joints connecting the upright assembly to the chassis define the steering axis. This axis is extremely important in determining the handling characteristics of the vehicle.

1.2. Steering gears and steering ratio

Steering ratio is a trade-off between quick response and low driver effort. Steering wheel to road wheel angle ratios vary dependent on suspension characteristics but have nominal values of approximately 15:1 in passenger cars [7]. Higher steering ratios (20:1) like that used in speedway cars [9] mean that the driver input is transferred to a change in wheel angle takes a longer time; however, the amount of force required to turn the wheel is low. In contrast, Formula 1 cars (10:1) [9] and go-karts (1:1) [9] with low steering ratios provide very quick and accurate steering response, but the force required to turn the wheel may be greater. FSAE judges and other design teams recommend that steering ratios between 5:1 and 10:1 be used for FSAE vehicles [4].

Besides, wheel angles range between 20 and 30 degrees to full lock and the corresponding steering wheel angle should be no more than 360 degrees “lock-to-lock” [6] and ideally around 270 degrees. This allows tight corners to be taken with minimal driver movement whereby the driver does not need to move or reposition his/her hands on the wheel for the entire steering range. These ranges correspond with steering ratios within the recommended range.

1.3. Free play in steering assembly

As noted by [9], there are many connections in a steering system, all of which can impart a degree of bending or deflecting resulting in slop or “free play” in the steering. Free play will make the steering imprecise, and consequently, the driver may not know the exact steer angle of the wheels at any given time; an obvious disadvantage in any vehicle. According to [5], the major source of free play in any steering mechanism is the steering gear; however, this factor must be considered in all components.

1.4. Steering system forces and moments

Forces measured at the centre of the tyre contact with ground provide a basis upon which to analyse the steering reactions. As noted by [7], ground reactions on the tyre (that is, factors affecting the steering force) can be described by four forces; vertical force, lateral force, tractive force and aligning force. The summation of these forces that describe the moments input to the steer axis of each wheel coming from the forces and moments acting on the tyres can be used to determine the torque feedback to the steering wheel [7].

$$\text{Vertical force: } M_v = -(F_{zl} + F_{zr})d \sin \lambda \sin \delta + (F_{zl} + F_{zr})d \sin \nu \cos \delta \quad (1)$$

$$\text{Lateral force: } M_l = -(F_{yl} + F_{yr})r \tan \nu \quad (2)$$

$$\text{Tractive force: } M_t = -(F_{xl} + F_{xr})d \quad (3)$$

$$\text{Aligning torque: } M_{at} = M_{zl} + M_{zr} = \sqrt{\lambda^2 + \nu^2} \quad (4)$$

Where:

- F_{zl} & F_{zr} = Vertical forces on the left and right wheels.
- F_{yl} & F_{yr} = Lateral forces on the left and right wheels.
- F_{xl} & F_{xr} = Tractive forces on the left and right wheels.
- d = Lateral offset at the ground.
- r = Tyre radius.
- λ, δ, ν = Lateral inclination, steer, and caster angles, respectively.
- M_{zl} & M_{zr} = Aligning torques on the left and right wheels.

1.5. Existing designs review

During the specification stage, research was done into currently engineered designs from different university teams. There are a large number of different upper stage steering assembly designs used within the FSAE competition, mostly dependent upon frame and upright geometry.

1.6. Functional components

The design of the upper stage steering system was divided into components for design analysis purposes. Specifically, this included:

- Steering wheel: to transfer force imparted by the driver on the out rim of the steering wheel to the steering shaft, hence, allowing the steering assembly to effectively transfer driver input into car control.
- Quick release mechanism: to transmit torque from the steering wheel to the steering shaft. In addition to this relatively simple purpose, it must allow the steering wheel to be removed quickly and easily from the assembly such that driver egress can occur.
- Steering shaft: to transmit torque from the quick release mechanism to the universal joint.
- Universal joint: to transfer torque from the upper to lower steering shaft.

2. DESIGN APPROACH AND SPECIFICATION DEVELOPMENT

To understand the factors influencing the design problem [2], a comprehensive review of ergonomic, geometric, and loading constraints was conducted.

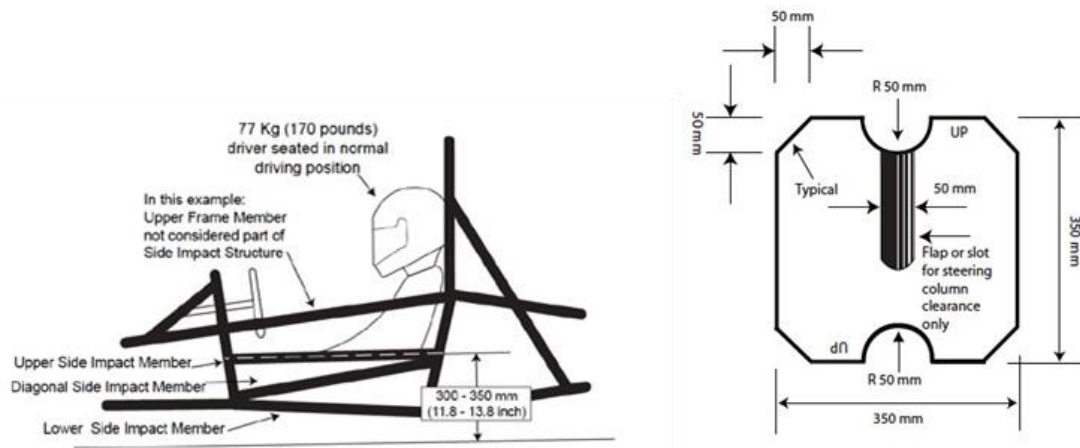

Fig. 1. Section view of driver FSAE driver cockpit illustrating constraints regarding the steering wheel location and template used in testing

2.1. Ergonomic constraints

As stated in the FSAE 2011 rules, clause A1.2.2, the vehicle must accommodate drivers whose stature ranges from 5th percentile female to 95th percentile male. Based on observation of existing FSAE designs, driver experience within the group, and recommendations from [13]; the steering wheel should sit at approximately 10° to the horizontal and at 90° to the angle of the front hoop part of the frame when looking in section.

According to [4], most FSAE cars have the steering wheel positioned around 300-450 mm away from the driver's chest for optimum ergonomics. According to [13], the preferred driver positions with a back angle in the range of 25 to 35° from the vertical and recommend a seat back angle of 30° and a steering wheel angle of 7° .

Data from [4, 11, 13] and FSAE were integrated into a sketch, Fig. 2, to ascertain the optimum location for the centre of the steering wheel.

2.2. Geometric constraints

As the frame of "Omega" is already constructed and considered to be of sound design, a key parameter influencing the design problem was the existing geometries, within which the upper stage steering assembly must perform its desired function. Set dimensions influencing the development of a steering system include the front hoop geometry, seat location and rack and pinion positioning.

The most geometrical constraints that the upper stage steering assembly must abide by are:

- angle that must be resolved between the rear of the front hoop and centre rack and pinion is 158° or a 22° deflection from the angle of the upper stage steering shaft,
- the upper stage steering shaft must pass the normal front hoop 191.75 mm from the top of the front hoop along a plane inclined from the horizontal by 10° .

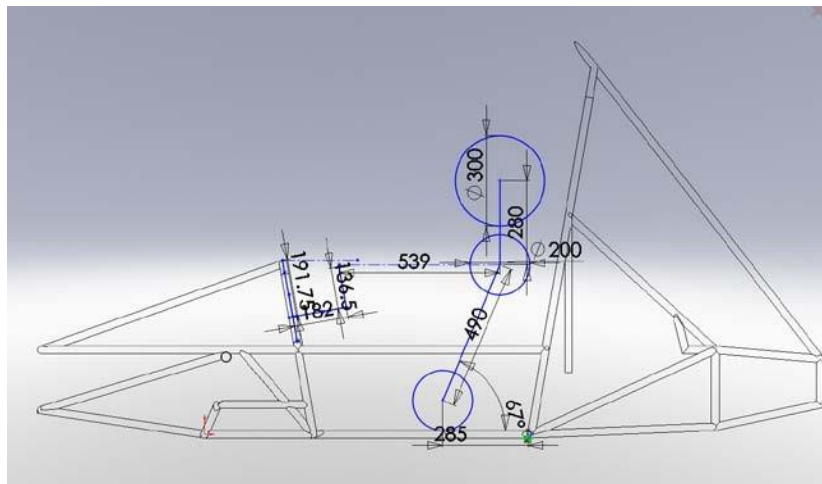

Fig. 2. “Percy” template seated in the vehicle

2.3. Loading determination on upper stage assembly

Loading on the upper stage steering assembly can be effectively divided into two components; bending loading and torsional loading. For bending loading, the steering assembly must be able to withstand 660 N of radial force applied at the steering wheel in any direction without failure [4]. Although this force would only be applied in extreme circumstances, it is a fundamental requirement of the design that this loading is adhered to as failure of the steering assembly will result in further endangerment through the lack of vehicle control. The driver should not be required to exert any radial load on the steering assembly during normal operation. However, a nominal value of around 10 N is assumed based on a secondary force that may be applied by the driver when turning the wheel.

Torque can be exerted on the upper stage steering assembly by the road-tyre interaction and by driver input. For the driver imparted torque, Fox [4] compiled data on the maximum torque that can be exerted by a driver using a 254 mm diameter steering wheel with arms fully extended, at mid-reach and close to the chest. This data concludes that any “well-constructed” FSAE car should be able to withstand a minimum of 135 N.m of torque applied at the steering wheel (Table 1).

The road-tyre interaction imparted torque depends on the geometry of the system, and the speed and angle of cornering. Due to the large coefficient of friction between the tyres and road at standstill, it is reasonable to conclude that the maximum torque required to turn the wheels of an average FSAE car is 411 N.m [4], will be present when the car is stationary. Assuming a nominal pinion diameter of 16.7 mm is connected directly to the lower steering shaft, the torque needed to provide 1533.36 N of translational force to the pinion mechanism is calculated as 25.607 N.m.

Tab. 1

Key constraint summary

Key factor	Constraint
Angle of shaft	12-32°
Length restriction (along longitudinal frame axis)	210 mm
Maximum radial loading	660 N

Normal radial loading	10 N
Maximum axial loading	660 N
Normal axial loading	0 N
Maximum torque	135 N.m
Normal torque	11 N.m

3. CONCEPT DEVELOPMENT

The concept development stage of the design process encompassed the examination of design alternatives for each functional component. From this, preliminary design decisions were made for further detailed design analysis.

3.1. Universal joint

Several universal joint components were considered for the assembly. A decision matrix ranking their merits is provided in Tab. 2, showing that a needle bearing universal joint is the most suitable coupling mechanism for the assembly.

Tab. 2

Concept design analysis rankings for universal joint options

	Friction bearing single	Friction bearing double	Needle bearing single	Needle bearing double	BMW assembly
Free play	5	5	10	10	N/A
Cost	7	3	5	1	10
Weight	7	3	7	3	8
Angular velocity fluctuation	5	10	7	10	10
Load rating	10	10	10	10	N/A
Reliability	8	8	10	10	N/A
Suitability	10	5	10	5	0
Total score	52	44	59	49	33

* All options were rated out of a maximum of 10

3.2. Upper steering shaft

From the loading analysis, several calculations were undertaken to provide a suitable diameter for the upper stage steering shaft. These calculations, in Tab. 3, were performed following AS1403 - Design of rotating steel shafts. A nominal 20 mm shaft diameter was assigned according to von-Mises stress.

Tab. 3

Calculated minimum shaft diameters

Approach	von-Mises	Goodman	AS1403 Formula 1	AS1403 Formula 2
Min. shaft dia. (mm)	20.22	27.87	20.206	33.45

3.3. Bearings

Four preliminary bearing designs were researched and evaluated by a decision matrix (Tab. 4). Based on the dimensional and functional constraints, the Spyraflow Pillow Block Bearing and igubal® Pillow Block Bearing were chosen due to their weight and height, as a main bearing and a lower shaft bearing, respectively.

Tab. 4

Bearing specification summary

	SKF Pillow-Block Bearing	SKF Y-Bearing Plummer Block	Spyraflow Pillow Block Bearing	igubal® Pillow Block Bearing
Weight (kg)	0.24	0.24	0.1	0.0274
Radial Load Capability (kN)	12.7	12.7	6.6	2.4
Height (mm)	64	50	39.5	40

3.4. Connection points to frame

The connection points to the frame are of the highest importance to the design of a steering system. The connections must be designed to satisfy the frame constraints and to withstand any force transmitted from the steering system through the bearings. The two most common methods to attach the steering system is to either bolt or weld it to the frame. From the pillow-block bearing design, the best solution was a bracket design to be welded into the frame with the bearing and steering assembly bolted to it. This design allows for the ease of removal and maintenance of the whole steering assembly.

To further stabilise the steering assembly and reduce free play in the system, the decision was made to add a secondary bearing between the universal joint and the rack and pinion. This meant that the design for the brace had to be modified to allow the second bearing support. The conceptual secondary brace design is dependent upon the exact angle of the lower stage steering shaft orientation, and consequently, the steering gear design. It is important to note that using this design, the entire steering assembly can be easily removed from the car by removing the four bolts that hold the two bearing housings to the brace component.

3.5. Quick release mechanism and steering wheel

The lifeline quick release steering boss is CNC manufactured using aircraft quality aluminium hard anodised for strength and durability (Table 5). Both male and female splines are precision gear cut incorporating a master spline for accurate alignment. The male spigot, which needs to be welded to the upper steering shaft, can be manufactured from three materials, one of which is EN3B, also known as AS1018, a compatible material for welding to our shaft. It is the same diameter as our shaft, which will allow for a simple sleeve joint welded to the spigot and shaft.

In terms of dimensions, formula racing steering wheels tend to be smaller than usual steering wheels to limit the range of movement a driver has to make to turn it. Although a steering wheel diameter is a personal preference, however, an acceptable range is around or less than 10 in. The wheel also has to be small enough that in any angular position, the top of the steering wheel

will not be any higher than the top-most surface of the front hoop. Lastly, the wheel needs to be of a shape that permits easy access to the quick release mechanism. The Mod 103 Momo Steering Wheel suits all these needs and is relatively cheap at US\$125.

Tab. 5

Quick release mechanism evaluation

Criteria	Price	Simplicity	Strength	Availability of Details	Suitability	Ease of use	Total
Weight	10	6	6	8	8	10	48
Lifeline	4	8	10	6	10	10	48
Works Bell Rapfix	4	2	8	2	4	6	26
Overship	10	2	2	0	4	2	20
Jegs	10	6	2	8	10	4	40

* All options were rated out of a maximum of 10

3.6. Universal joint connection

The universal joint is designed to mate to the upper stage steering shaft through a key. To constrain movement between the steering shaft and the universal joint in the axial plane of the shafts, grub screws were designed. A sleeve coupling mechanism was designed for the connection of the quick release male spigot to the upper stage steering shaft. The supplier recommended this mode of connection over a simple butt weld. The exact sleeve weld thickness and length was confirmed through FEA analysis.

4. FINITE ELEMENT ANALYSIS

All parts of the steering assembly were modelled in the FE software ANSYS (Table 6). Six models (Fig. 3) were created in a 3-D space and solved for von Mises' stress, von Mises' strain, total deformation, fatigue life, damage, and safety factor. The fatigue portion of the results were all analysed with the Goodman criterion and a fully reversed load.

Mesh refinements were added on the corners, welding, and contact regions. A frictionless contact was created to simulate the bearings in the spider while the other contacts (the key with the shaft and welds on the sleeve and the respective shafts) were modelled as a bonded contact. In addition, a fatigue factor of 0.68 was incorporated into the analysis to compensate for the key slot in the shaft.

Tab. 6

FEA models' summary

	Mesh and refinement	B. C.	Applied load
Universal joint	0.003 m 0.0001 m	Fixed at one yoke and loaded on the other	Torque = 135 N.m Axial load = 660 N

Steering	default	Fixed at the end of the shaft	Torque = 135 N.m (on the key) Axial load = 660 N (on the shaft)
Main brace	default	Fixed at the holes in housing	Bending moment = 105.5 N.m (about the y-axis)
Secondary brace	default	-	-
Secondary bearing	default	-	-
Main bearing	default	-	-
Sleeve	0.001 m 0.0005 m	Fixed at one end and loaded on the other	Bending moment = 54.78 N.m
Steering shaft	default	Fixed at the end of the shaft	-
Spigot	default	-	Torque = 135 N.m

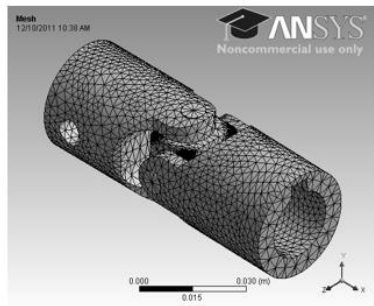

(a)

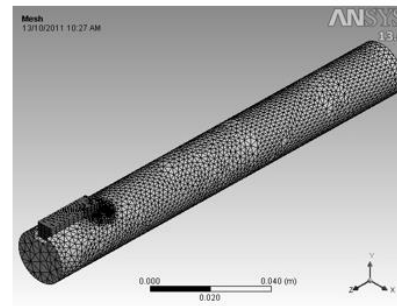

(b)

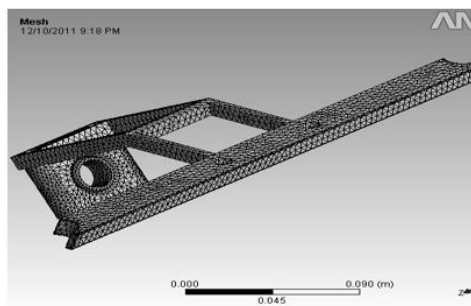

(c)

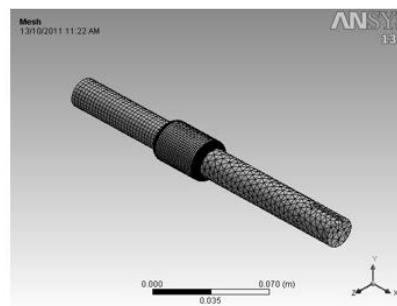

(d)

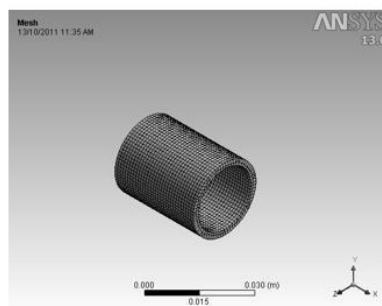

(e)

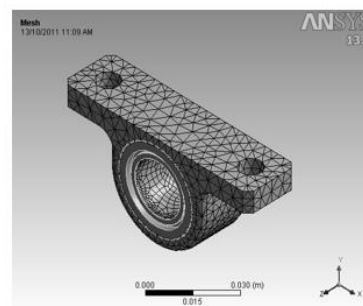

(f)

Fig. 3. Mesh of universal joint (a), steering shaft (b), main brace and secondary bearing assembly (c), welds (d), sleeve (e), and main bearing (f)

5. RESULTS

Generally, FEA results showed that the design will perform correctly during its service.

For the universal joint, the equivalent stress and fatigue life are plotted in Fig. 4 and showed that this component will safely transfer torques from the upper steering shaft to the lower one.

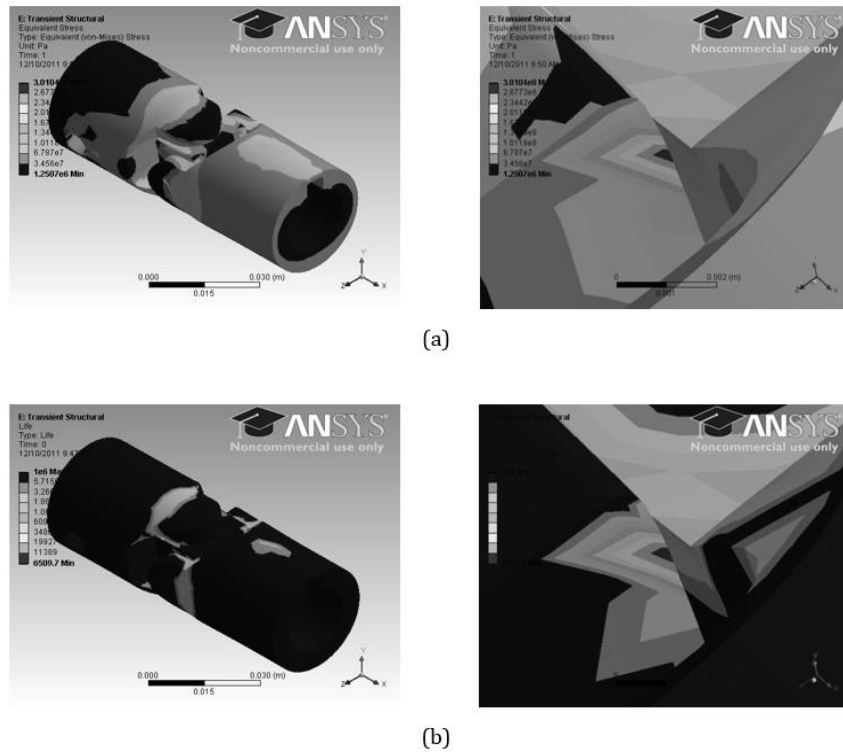

Fig. 4. Equivalent stress (a) and fatigue life of the universal joint (b)

For the steering shaft, the equivalent stress and fatigue life are plotted in Fig. 5. These values confirmed that the shaft is capable to transmit torques, from the quick release mechanism to the universal joint, without failure.

The sleeve was designed for connecting the quick release male spigot to the upper steering shaft. It was welded to them, as recommended by the supplier. Results, in Fig. 6 and Fig. 7, proved that sleeve and welds, respectively, will withstand all forces transmitted through them.

For the main bearing housing and brace assembly, their equivalent stresses and fatigue lives are plotted in Fig. 8 and Fig. 9, respectively, and evidenced that their performance during service will be safe.

Conclusively, the results of all models are summarised in Tab. 7.

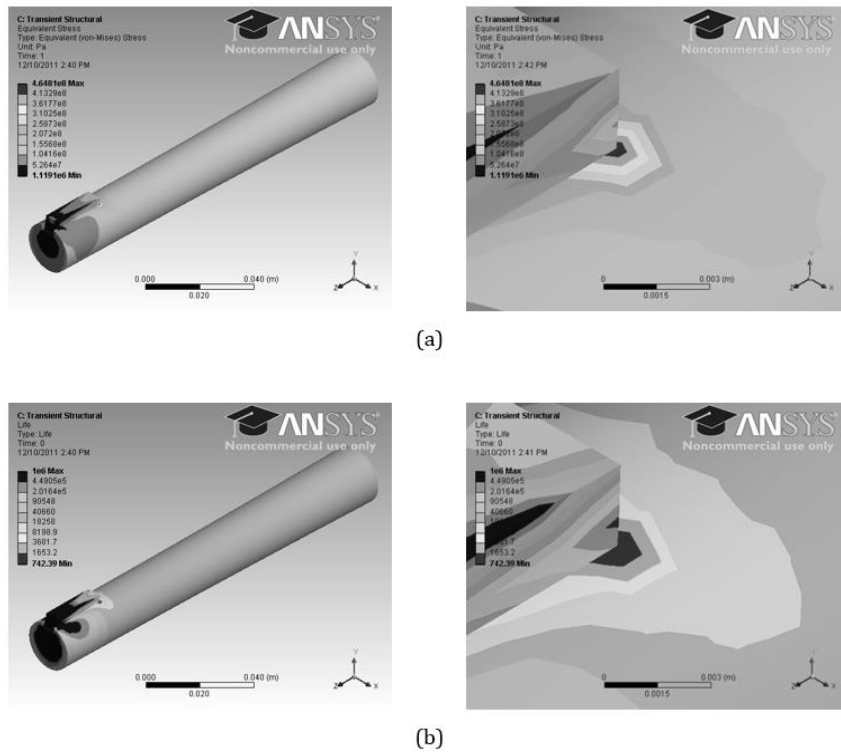

Fig. 5. Equivalent stress (a) and fatigue life of the steering shaft (b)

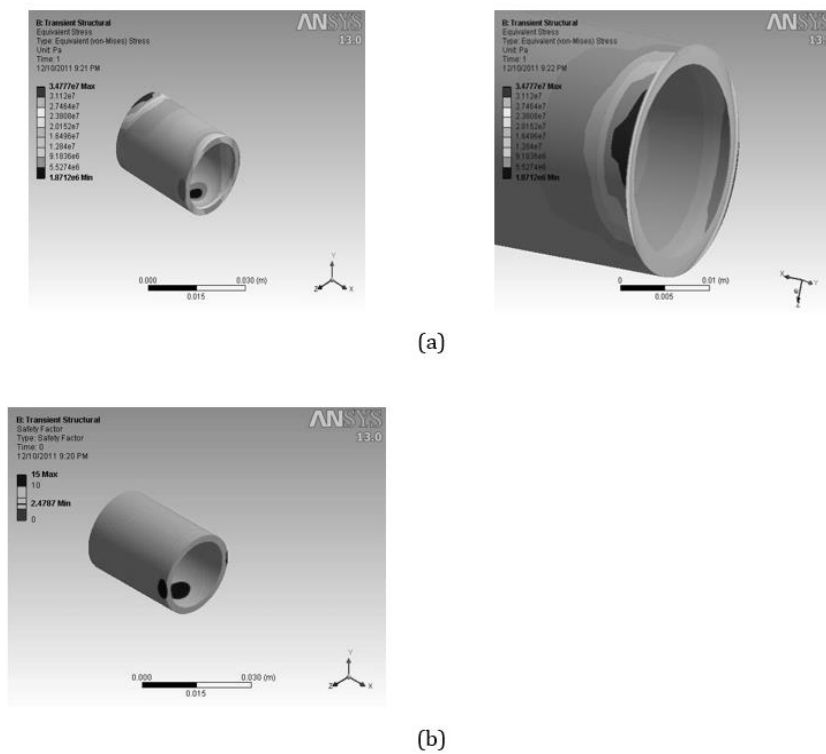
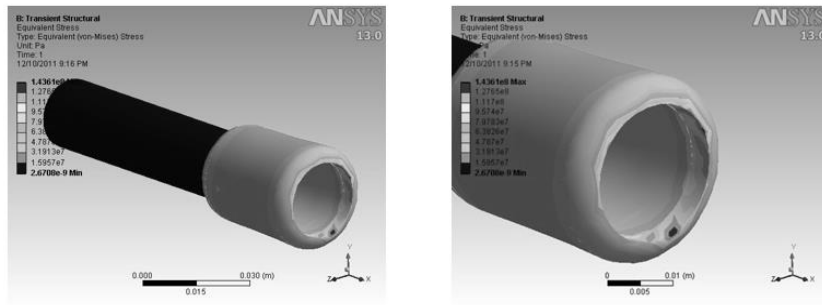
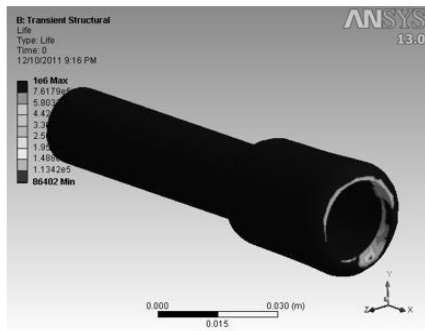

Fig. 6. Maximum stress (a) and safety factor of the sleeve (b)



(a)



(b)

Fig. 7. Equivalent stress (a) and fatigue contour on welds (b)

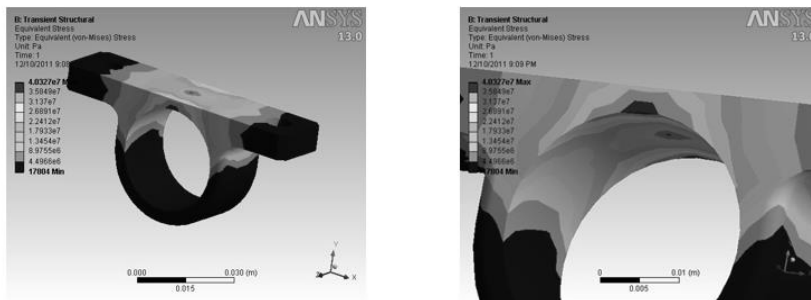

(a)

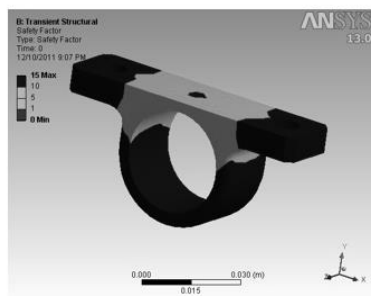

(b)

Fig. 8. Equivalent stress (a) and safety factor on the main bearing housing (b)

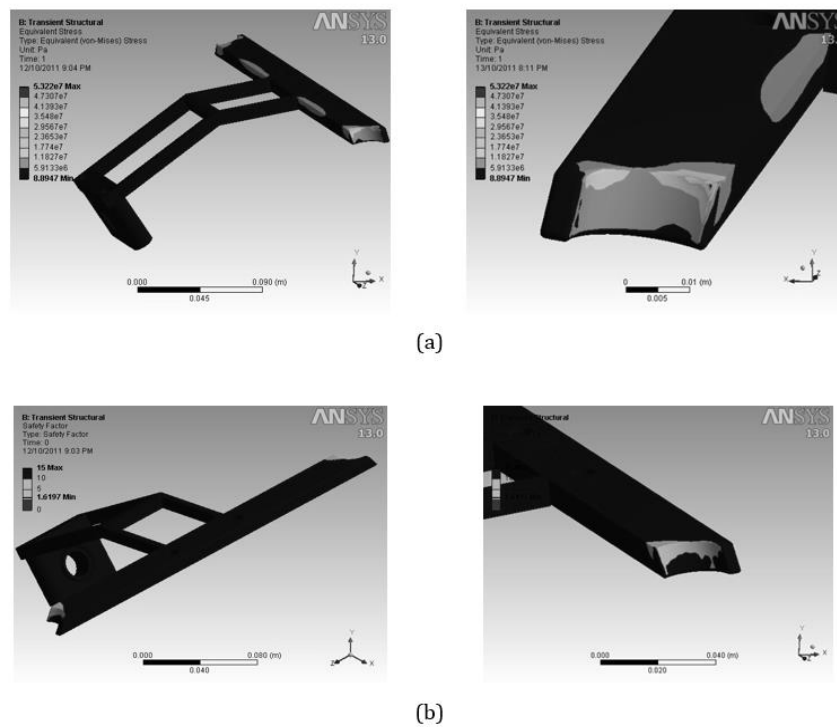

Fig. 9. Equivalent stress (a) and safety factor on the brace assembly (b)

Tab. 7

Summary of FEA results

Part	Total deflection	Max stress	Life
Universal joint	0.048 mm	301 MPa	6,509 cycles
Steering shaft	0.23 mm	464.8 MPa	742 cycles
Main brace	0.02 mm	34.8 MPa	-
Welds	-	60 MPaa	86,402 cycles
Main bearing	7.11 μ m	40.3 MPa	-
Brace assembly	0.015 mm	53.2 MPa	-

6. CONCLUSION

The objective of this work was to provide a preliminary arrangement and sizing of structural components for an upper stage steering assembly for the Formula FSAE car of “Omega”. The investigated parameters were performance, weight, cost, ergonomics, maintainability, manufacturability and reliability.

First, reviews of ergonomic, geometric, and loading constraints according to the FSAE 2011 rules were conducted. The selected design of the steering system is consisting of a steering wheel, steering shafts, universal joints, quick release mechanism, and connection points to the car.

Then, several design alternatives for each functional component were evaluated, and the design decisions were made by using decision matrices.

Finally, critical forces and moments acting on the tyres and steering wheel were determined and applied to the respective structural parts, using the FEA software package of ANSYS to determine the corresponding stresses and margins of safety, which was found to be positive along the components of the steering assembly showing good enough strength.

References

1. Crolla David. 2009. *Automotive Engineering*. London: Elsevier. ISBN 978-1-8561-7577-7.
2. Dyakov Ivan, Olegas Prentkovskis. 2008. "Optimization problems in designing automobiles". *Transport* 23(4): 316-322.
3. ELESA+GANTER. „Universal Joints”. Available at: <http://www.elesa-ganter.com>.
4. Formula SAE. „Cockpit Control Forces or How Robust Do Driver Controls Really Need To Be?”. Available at: <http://www.fsaonline.com/content/Cockpit%20Control%20Forces%20SI%20SAE.pdf>.
5. Fulmer Matthew. 2009. „Reducing Free Play in an Automotive Steering System Public”. Student Work, Worcester, MA, USA: Worcester Polytechnic Institute.
6. Gaffney Edmund, Anthony Salinas. 1997. „Introduction to Formula SAE Suspension and Frame Design”. In 48th Earthmoving Industry Conference and Exposition: 1-11. SAE International, Warrendale, PA, USA. 09-10 April 1997, Peoria, Illinois, USA. ISSN 0148-7191.
7. Gillespie Thomas. 1992. *Fundamentals of Vehicle Dynamics*. Warrendale: SAE International. ISBN 978-1-56091-199-9.
8. Juvinal Robert, Kurt Marshek. 2006. *Fundamentals of Machine Component Design*. Texas: John Wiley and Sons. ISBN 978-1-119-32153-8.
9. Milliken William, Douglas Milliken. 1995. *Race Car Vehicle Dynamics*. Warrendale: SAE International. ISBN 978-1-56091-526-3.
10. Pacejka Hans. 2006. *Tire and Vehicle Dynamics*. London: Elsevier. ISBN 978-0-7506-6918-4.
11. Peacock Brian, Waldemar Karwowski. 1993. *Automotive Ergonomic*. London: Taylor and Francis. ISBN 978-0-7484-0005-8.
12. Shock and Vibration Components. „The analytical design of universal joints”. Available at: <http://vibrationmounts.dev.inquestmarketing.com/V100/PDF/VM11004.pdf>.
13. Way Michelle, Nicole Berndt, Badih Jawad. 2003. „The Study of a Cockpit with a Fixed Steering Wheel Position: Methods and Model”. In Digital Human Modeling for Design and Engineering Conference and Exposition: 1-7. SAE International, Warrendale, PA, USA. 16-19 June 2003, Montreal, Canada. ISSN 0148-7191.

Received 12.10.2021; accepted in revised form 19.11.2021



Scientific Journal of Silesian University of Technology. Series Transport is licensed under a Creative Commons Attribution 4.0 International License