

THE ANALYSIS OF CHOSEN TECHNOLOGICAL PARAMETERS IN THE PROCESS OF MANUFACTURING COMPONENTS OF LANDING GEAR OF STRUCTURAL POST AIRCRAFT

Piotr Boś, Mikhael Hakim

*Państwowa Wyższa Szkoła Zawodowa w Krośnie im. Stanisława Pigonia
Rynek 1, 38-400 Krosno, Poland
tel.: +48 134375570, fax: +48 134375571
e-mail: piotrb44@wp.pl, mhakim@o2.pl*

Grzegorz Budzik

*Politechnika Rzeszowska, Katedra Konstrukcji Maszyn
Powstańców Warszawy Av. 8, 35-959 Rzeszów, Poland
tel.: +48 178651986
e-mail: gbudzik@prz.edu.pl*

Mirosław Rybak

*Goodrich Aerospace Poland Sp. z o.o.
Żwirki i Wigury Street 6a, 38-400, Krosno, Poland
tel.: +48 13 4376600, fax. +48 13 4322006
e-mail: miettek@interia.pl*

Abstract

High quality of components used in constructions of Landing Gears forces the manufacturers to choose appropriate technologies in order to manufacture and control dimensions of particular details. It is especially difficult to predict how the elements of huge dimensions will act during heat treat and chemical processing. The changes in size and shape of the elements of suspension of STRUCTURAL POST aircraft are connected with hardening stresses. This requires accurate determining of allowance of final machining. The analysis of processing parameters and manufacturing of a precise component is possible with the use of high-tech coordinate measuring techniques based on touch and untouched measurements. The highest quality of machines used in manufacturing and measuring as well as innovative technologies used during the process of manufacturing STRUCTURAL POST components result in effects assumed by the designing engineer. The aim of this article is to present issues connected with technological process of manufacturing STRUCTURAL POST components as well as the analysis of particular parameters of manufacturing process which have an impact on the accuracy of dimensions and shape of the final product. These parameters are also responsible for functionality, operational reliability and safety of the Landing Gear.

Keywords: *transport, aviation, landing gear, measuring method, engineering*

1. Introduction

The production process of elements of STRUCTURAL POST type begins with making a steel forged form in a foundry for further heat processing (in most cases it is steel 4340 300M). The construction of landing gear of an aircraft necessitates specific shape of the element which reminds a cylinder with protruding elements for mounting and it is difficult to manufacture (Fig. 1).

We can obtain a proper form thanks to different kinds of machining. During the production process about 80% of the forging's material is removed. In general, the beginning of technological

process can be divided into the following types of processing:

1. qualifying,
2. drilling,
3. profiling,
4. turning,
5. deburring,
6. in process inspection.



Fig. 1. The example of an element of STRUCTURAL POST type

As a result, the manufactured element has a specific form together with initially assumed allowance material for final treatment. Thanks to the use of the latest technologies we get the assumed accuracy of dimensions, form and location [1]. Variable cross-section on the length and, what follows it, different time of cooling in later phase of heat treatment, has an impact on hardening stress and the change of the element's dimensions. During the process of hardening elements undergo distortion and torsion. It also often happens that they become oval due to a specific shape of the elements: long bushing with thin walls thickness and clear passages into massive mounting lugs. Next, the element undergoes an arduous process of straightening and tempering so that the allowance material left for the final machining was enough to receive so called characteristic dimensions, which must be checked in the final element. We must not forget that during the production process of aviation elements it is necessary to follow proper aviation standards namely AS 9100 and AS 9102 (FAI) which require to carry out FA- 100% of measurements characteristic of the elements. The aim of these actions is to present an objective proof that all the requirements are explicitly understood, investigated and documented. Those standards force the manufacturers to create sections responsible for testing measurable key characteristics.

Straightening process, which is based on workers' experience as well as on the working procedures after being repeated several times usually ends with obtaining a satisfying form of the element. Each straightening operation is connected with a measuring process [3]. In the diagram, the whole process can be described as follows:

1. hardening,
2. snap tempering,
3. distortion test after h/t,
4. temper hot straightening i,
5. distortion re-inspection,
6. temper hot straightening ii,
7. distortion re-inspection,
8. temper hot straightening iii,
9. final tempering,
10. hardness test,
11. mechanical properties check.

There is a need to work out a quick and accurate measuring method which does not suspend production process and provides with a defined dimensional accuracy of the dimensions, deviations in the form and location. At present measurements are usually taken with universal measuring tools and special devices adapted to particular types of elements based on center line fixture (Fig. 2), flat tapers, bench plates etc.

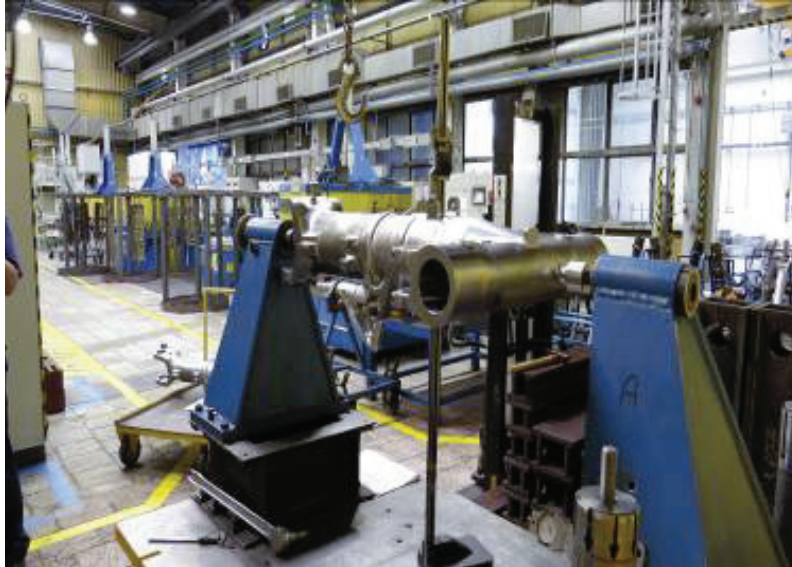

Fig. 2. The measurement of height in relations to a bench plate

Therefore, a lot of new workstations should be created. Special appliances are expensive and they take a lot of space, proportionally to the size of the manufactured elements. While introducing new elements into production, new measuring devices are made, new workers are trained how to use them properly and new measuring procedures are worked out. The warehouse for measuring appliances is built. Tests conducted with Coordinate Measure Machine (CMM) produced the effect-the measurements were more accurate, at least of one level of precision [5-6].

CMM measurement is more universal and excludes the necessity of using numerous appliances. It is usually enough to have several basic, universal additional tools to use with it. Unfortunately, the measurement is connected with transfer of the element to the measuring machine room, tooling setup and checking particular dimensions which is effortful and causes significant extension of time of the operation (Fig. 4).

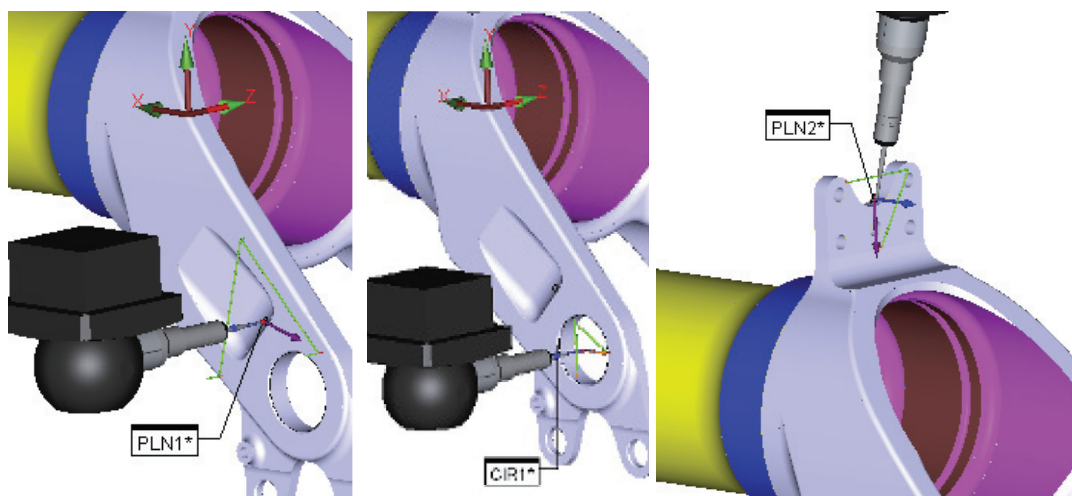

Fig. 3. Modelling of the measurement on the Coordinate Measure Machine



Fig. 4. Taking measurements on the Coordinate Measure Machine

Adding a laser head to a Coordinate Measure Machine shortens the measuring time but, unfortunately, dampens the measuring accuracy (Fig. 4). There are also problems with reflection of light and checking internal dimensions/ID-inside diameters. Additionally, there still is a problem with transporting the parts to the measuring machine room.



Fig. 5. The measurement taken on the Coordinate Measure Machine equipped with a laser head

Application of CMM, even in spite of their high accuracy, is insufficient regarding the needs. Thus, there is a need for more effective measuring methods retaining current precision of the measurements.

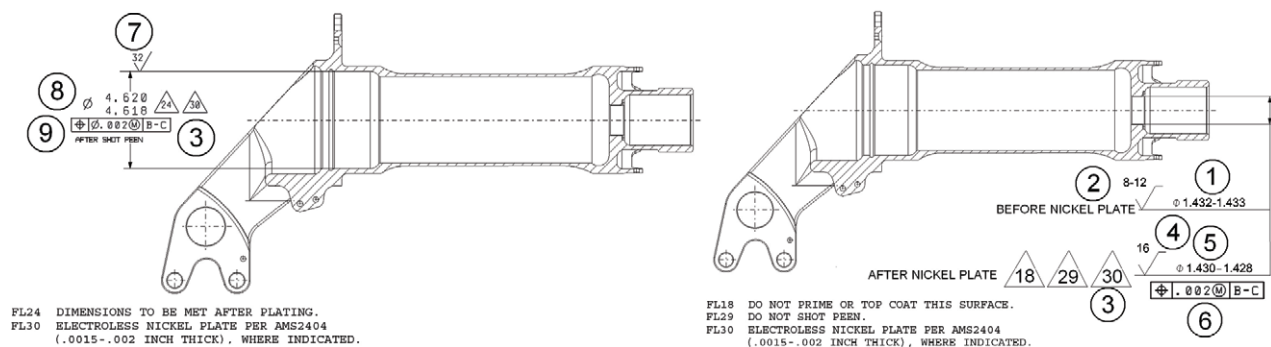

Fig. 6. The set of key characteristics of the elements of STRUCTURAL POST type [4]

Tab. 1. Exemplary results of the measurements taken on key characteristics of STRUCTURAL POST elements (the measurements of length are given in inches, of coarseness in microinches)

Key Characteristics No.	1	2	3	4	5	6	7	8	9
Characteristics	Ø1.432 /1.433	Ra 8-12	.0015 / .0020	Ra16	Ø1.430 /1.428	L .002m B-C	Ra32	Ø4.620 /4.618	LØ.002m B-C
KPB 000010	1.4323	12	0.00181	10	1.4291	0.0006	28	4.618	0.0004
KPB 000011	1.4323	11.5	0.00181	15	1.4292	0.0009	30	4.618	0.0006
KPB 000012	1.4321	12	0.00181	15	1.4295	0.0007	29	4.618	0.0006
KPB 000013	1.433	8	0.0016	12	1.43	0.0007	31	4.6189	0.0005
KPB 000014	1.433	8	0.0016	10	1.43	0.0005	30	4.6188	0.001
KPB 000015	1.433	10	0.0017	11	1.4299	0.0004	30	4.619	0.0018
KPB 000016	1.433	8	0.0015	10	1.43	0.0006	24	4.619	0.0005
KPB 000017	1.433	9	0.00161	10	1.43	0.0006	27	4.619	0.0007
KPB 000018	1.4324	9	0.0017	12	1.429	0.0004	22	4.619	0.0004
KPB 000019	1.432	9	0.0016	10	1.4288	0.0008	30	4.6186	0.0002
KPB 000020	1.432	11	0.0017	13	1.4286	0.0011	27	4.6185	0.0009
KPB 000021	1.4321	12	0.00175	14	1.4286	0.0009	26	4.6193	0.0007
KPB 000022	1.4325	11	0.0019	13	1.4287	0.001	28	4.6183	0.0007
KPB 000023	1.4322	8	0.0019	10	1.4284	0.0012	27	4.6182	0.0003
KPB 000024	1.4324	10	0.0019	12	1.4286	0.0014	30	4.6182	0.0007
KPB 000025	1.4326	10	0.0018	12	1.4289	0.0008	18	4.6189	0.0009

Analyzing the measurements presented above (Tab. 1) (Fig. 6), we can state that there are some slight discrepancies in the dimensions of the measured key characteristics but these discrepancies are within tolerance limits. This means that the applied measuring methods meet their objectives. However, the problems described earlier remain unsolved.

Conclusions

At present we can observe an intensive development of the untouched methods. Contrary to coordinate machines, it is possible to transport the optical system, which is important in case of the lack of possibility to transport an item. Systems based on untouched methods are more universal than Coordinate Measure Machines and have a wide range of application [7]. It is possible to use them not only for measuring the exact elements but also for measuring those of a bigger size. The elements that are modelled at the stage of construction, may serve as a model to compare with a map of points created with the use of the untouched method (Fig. 7) [2]. The process may concern the final product but it can also be used earlier, during process measurements.

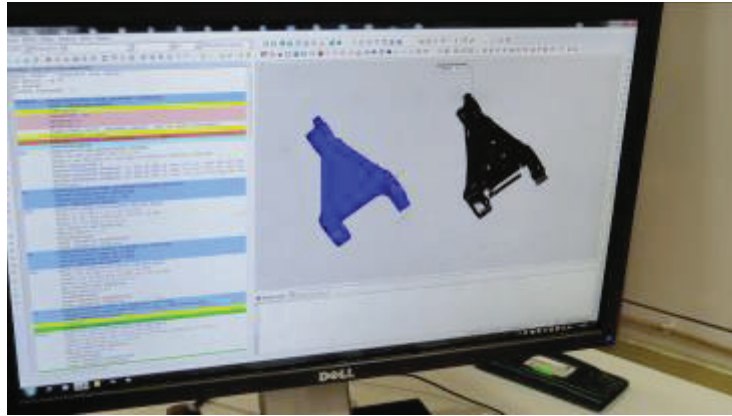

Fig. 7. Overlying of the model on the scanned element

The efficiency of the measuring process depends on the accuracy of the equipage of the measuring device but also on the knowledge and skills of the operator himself. The choice of a measuring strategy allows us to shorten the time of the measurements and to preserve or even improve the accuracy of the results of the measurements.

References

- [1] Budzik, G., *Synteza i analiza metod projektowania i wytwarzania prototypów elementów o skomplikowanych kształtach na przykładzie wirników turbosprężarek*, Oficyna Wydawnicza Politechniki Rzeszowskiej, Rzeszów 2007.
- [2] Filipowski, R., *Wspomaganie komputerowe przy pomiarze krzywych wypukłych na współrzędnościowej maszynie pomiarowej*, pp. 287, *Mechanik* nr 8-9/1993.
- [3] Grzelka, M., Gapiński, B., Marciniak, L., Wieczorowski, M., Maliński, K., Olszewska, I., *Pomiary cech geometrycznych przedmiotów obrotowo – symetrycznych*, *Miesięcznik Naukowo-Techniczny, Pomiary Automatyka Kontrola* ISSN 0032-4140, Vol. 56, pp. 35-37, 1-2010, Warszawa 2010.
- [4] Goodrich Aerospace Poland Sp. z o.o. materials property.
- [5] Ratajczyk, E., *Współrzędnościowa technika pomiarowa*, Oficyna Wydawnicza Politechniki Warszawskiej, Warszawa 2005.
- [6] Starczak, M., Płowucha, W., Jakubiec, W., *Pomiary powierzchni krzywoliniowych*, *Zeszyty naukowe PŁ Filii w Bielsku Białej* Nr 44, pp. 199, Bielsko Biała 1998.
- [7] Wieczorowski, M., Gruszka, J., *Wykorzystanie technik optycznych do kontroli produkcji tulei cylindrowych*, *Miesięcznik Naukowo-Techniczny, Pomiary Automatyka Kontrola* ISSN 0032-4140, Vol. 56, pp. 38-39 1-2010, Warszawa 2010.