

The Althoff-Radtke Test Adapted for High Chromium Cast Iron

D. Kopyciński^a, D. Siekaniec^{a,*}, A. Szczęsny^a, M. Sokolnicki^b, A. Nowak^b

^a AGH University of Science and Technology, Department of Foundry Engineering,
Al. Mickiewicza 30, 30-059 Kraków, Poland

^b Odlewnie Polskie S.A. based in Starachowice, al. Wyzwolenia 70, 27-200 Starachowice, Poland

*Corresponding author. E-mail address: dsiek@agh.edu.pl

Received 07.06.2016; accepted in revised form 14.07.2016

Abstract

The paper presents results of the possibility of adapting the Althoff-Radtke test for High Chromium Cast Iron. The Althoff-Radtke test is a clump attempt used for steel. The Althoff-Radtke test has four different lengths of clamp which qualifies it as a test to quantitatively take into account different kinds of shrinkage ΔL . The length of the slot of the cracked corner and the length of each staple (50 - 350 mm) are the parameters tendency to cast cracks. Castings of white cast iron have a high tendency to hot cracking due to the large range of solidification temperatures, unfavorable kinetics parameters of shrinkage, and especially a lack of expansion before shrinkage. Shrinkage of high chromium white cast iron is similar to the shrinkage of cast steel, and is approximately 2%. Therefore it is important to test susceptibility to hot cracks. Research was carried out under industrial conditions. Four melts were performed, one of the initial chemical composition and the other three modified by different amounts of Fe-Ti, respectively, 0.25%, 0.5% and 0.75% Fe-Ti. The propensity for hot cracking was based on the observation of the dark surface in the corner of the sample. The study shows that the Althoff-Radtke test can be adapted to determine the tendency for hot cracking of high chromium cast iron. It should however be noted that the test results can not be compared with those for other alloys.

Keywords: Mechanical properties, Castings defects, Hot crack, High chromium cast iron, Modification.

1. Introduction

Cracks are frequent casting defects, especially hot cracks. Cold cracks occur in the cooling temperature (when the casting material already shows distinct elastic features), hot cracks occur in a liquid-solid state, especially when the temperature of the solidifying casting is close to the equilibrium solidus temperature, or below that temperature. This is due to the fact that near the solidus temperature, the solidifying metal has a very small capacity and a small deformation resistance [1].

Hot cracks can be identified on the basis of a dark surface, as the consequences of strong oxidation when passing through a high

temperature range. There are three main causes for these cracks occur [2,3]:

- Alloy characterized by a wide range solidification temperature;
- The shape of casting makes defined areas of the casting solidify at a lower rate than the others, and at the same are not sufficiently fed;
- In those areas stresses are formed.

As a numerical criterion for the tendency to hot cracking, it is assumed, among other things, the so-called "degree of strain localization (irregularity distribution)", defined as the difference between the relative values of deformation walls: thicker ε_1 and thinner ε_2 , or in general, the relative deformation: the maximum

and the minimum in two places of the cast. This value describes the formula:

$$L = m \sqrt{\frac{l_1 + l_2}{2l_1}} \left(\frac{\tau_1 - \tau_2}{\tau_1} \right)^a \mu \quad (1)$$

where:

m, a – factors dependent on the type of alloy;
 l_1, l_2 – length of the wall: thicker and thinner;
 τ_1, τ_2 – solidification time of the wall: thicker and thinner;
 μ – coefficient dependence on the resistance of the mold.

$$\mu = 1 - \frac{\varepsilon_{real}}{\varepsilon_{free}} \quad (2)$$

where:

ε_{real} i ε_{free} – represents actual shrinkage (inhibited) and the free shrink of the casting at the time of achieving a thicker wall in the lower limit of the temperature range and the formation of hot cracks.

In the case of rigid molds $\varepsilon_{real} = 0$ i $\mu = 1$.

The degree of localization strain caused by the temperature difference of various parts of the sample solidifying during the braking contraction, which determines the ratio of:

Table 1.

The relative tendency to hot cracking for selected white cast iron [2].

Type of cast iron	Content, %						Structure ⁽¹⁾	The relative tendency to hot cracking (degrees contractual)
	C	Si	Mn	Cr	Ni	Mo		
White unalloyed	2,54- 2,75	0,74- 1,00	0,58- 0,61	0,14	0,14	-	P + C	-
White martensitic (Ni-Hard)	2,45- 3,35	0,44- 1,11	0,70- 1,00	1,2- 2,3	3,8- 4,9	-	A + M + (Fe,Cr) ₃ C	1
High Chromium	2,61- 3,07	0,79- 1,17	0,73- 1,00	27,7- 30,2	2,10- 2,30	-	F + A + (Fe,Cr) ₇ C ₃	3
High Chromium	2,64- 2,80	0,56- 0,97	2,04- 2,80	15,60- 18,75	1,51- 2,50	-	A + (Fe,Cr) ₇ C ₃ + (Fe,Cr) ₂₃ C ₆	3
Medium Chromium	2,13- 2,18	0,35- 0,43	0,50- 0,66	12,30- 12,80	-	-	M + (Fe,Cr) ₇ C ₃	-
Chromium-Molybdenum	2,75- 3,05	0,44- 1,00	0,68- 0,85	12,30- 12,80	-	1,45- 1,57	M + B + A + (Fe,Cr) ₇ C ₃	2
Chromium-Molybdenum (15-3)	2,70- 3,00	0,52- 0,75	0,72- 1,16	12,30- 12,80	-	3,62- 3,83	M + B + A + (Fe,Cr) ₇ C ₃	-

⁽¹⁾ P – Pearlite; C – Cementite; A – Austenite; M – Martensite; B – Bainite.

Castings of white cast iron have a high tendency to hot cracking due to the large range of solidification temperatures, unfavorable kinetic parameters of shrinkage, and especially a lack of expansion before shrinkage.

$$L_1 = \frac{\varepsilon}{\varepsilon_{free}} \quad (3)$$

where:

ε – the actual relative deformation (shrinkage) in the critical part of the casting (the slowest cooled part) occurs;
 ε_{free} – free deformation of the same part of the casting.

An analysis of these issues shows that hot cracks are formed when, for various reasons, the value of L_1 exceeds the critical level. It has also been demonstrated that the critical value of L_1 is equal to the so-called. technological supply strength at a given temperature, described by ratio [4]:

$$n_l = \frac{R'_m}{\sigma} \quad (4)$$

where:

R'_m – tensile strength in the solidification range, MPa;
 σ – stresses in the sample, assuming a uniform distribution of strain, MPa.

Shrinkage of chromium white cast iron is similar to the shrinkage of cast steel, and is approximately 2%. Therefore it is important to test susceptibility to hot cracks [5-8]. The relative tendency to hot cracking for selected white cast iron is shown in Table 1.

In performed studies for high chromium cast iron, adapted to the Althoff-Radtke test used for steel castings, the Althoff-Radtke test consists in pouring a standardized mold (Fig. 1.) of liquid metal.

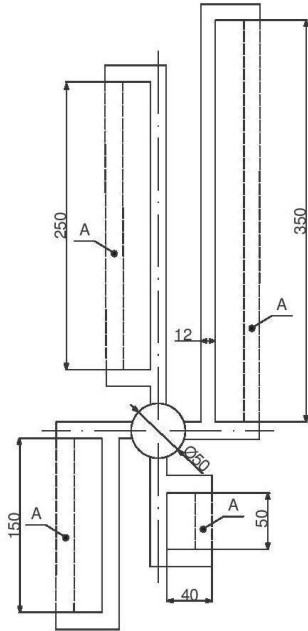

Fig. 1. Standardized form for Althoff-Radtke test [9]

It is a clamp attempt. The clamp arms stretched a rod with the same cross section as the sample clamp. The thermal centre of this attempt is formed in the corners of the clamp. This test has an unequivocally localized crack. The clamp after pouring, shrinks the " ΔL ", causing the bending of the arms. Strut "A" does not allow them to move parallel to the arms.

If cast iron has a high tendency to crack, a dark surface will be visible in the corner. If there would not be any visible changes it will indicate that the alloy has a high resistance to hot cracking. This type of comparative test is only valid for the same shrinkage ΔL , as for the same clamp length. The Althoff-Radtke test has four different lengths of clamp which qualifies it as a test to quantitatively take into account the different shrinkage of ΔL . The length of the slot of cracked corner and the length of each staple (50 - 350 mm) are parameters for a tendency to cast cracks [7, 9].

2. Methodology

The aim of this work was to verify the ability of adapting the Althoff-Radtke test for high chromium cast iron.

The mold was made by loose self-hardening moulding sands (Fig.2). Melts were carried out in industrial conditions. Performed series of melts for high chromium cast iron with a content of C \approx 2% and Cr \approx 21% were carried out. First with the initial chemical composition and the other three modified by different amounts of Fe-Ti, respectively, 0.25%, 0.5% and 0.75% Fe-Ti. The pouring temperature was 1530°C. The castings were knocked out and then the arm of the samples were broken.

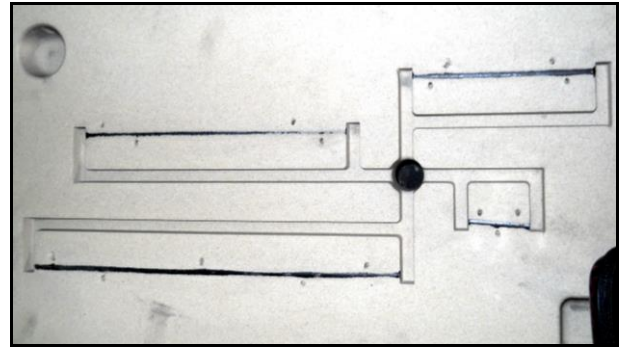

Fig. 2. Mold for Althoff-Radtke test

3. Results and discussion

The propensity to hot cracking was based on the observation of a dark surface in the corner of samples. Figures below show the obtained results. Figure 3 shows the reference sample, Figure 4, 5, 6 respectively showing samples modified by 0.25%, 0.5% and 0.75% Fe-Ti.

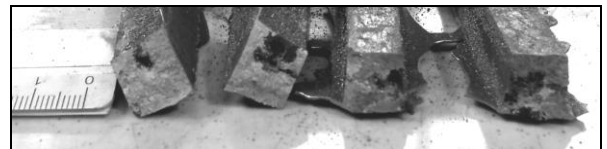

Fig. 3. Result of Althoff-Radtke test for reference sample; respectively, from the left arm length 50, 150, 250, 350 mm



Fig. 4. Result of Althoff-Radtke test for sample modified 0.25% Fe-Ti; respectively, from the left arm length 50, 150, 250, 350 mm

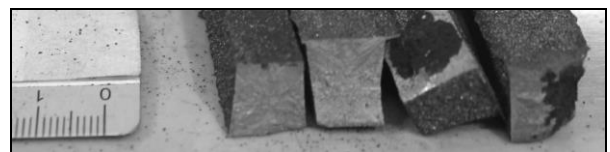

Fig. 5. Result of Althoff-Radtke test for sample modified 0.5% Fe-Ti; respectively, from the left arm length 10, 150, 250, 350 mm

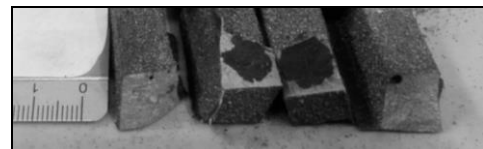

Fig. 6. Result of Althoff-Radtke test for sample modified 0.75% Fe-Ti; respectively, from the left arm length 50, 150, 250, 350 mm

The experimental results indicate that a modification of titanium reduces the tendency to hot cracking. Most preferably, the smallest addition of titanium (0.25% Fe-Ti) is affected. Modification 0.5% Fe-Ti minimized stresses in the shorter arms (50 and 150 mm), while on the longer arms (250 and 350 mm) there are visible dark areas. Modification of 0.75% Fe-Ti reduced tendency to hot cracking in the shortest arm (50mm).

Therefore, it can be noticed that a modification of titanium affects not only the improvement of hardness and abrasion resistance [5, 6], but the appropriate choice of amount of modifier may also reduce the tendency to hot cracking.

An analysis of the chemical composition of each sample are presented in Table 2.

Table 2.
The chemical composition of samples.

Sample	C	Si	Mn	P	S	Cr	Ni	Ti
As cast	1,99	0,538	0,454	0,020	0,013	21,8	0,160	0,0096
Modified 0.25% Fe-Ti	1,96	0,535	0,362	0,019	0,012	21,6	0,161	0,1290
Modified 0.5% Fe-Ti	1,87	0,483	0,386	0,018	0,011	21,6	0,165	0,2024
modified 0.75% Fe-Ti	1,86	0,602	0,442	0,017	0,012	22,4	0,234	0,4115

4. Conclusions

The present work, aimed at adapting the Althoff-Radtke test for High Chromium Cast Iron, led to interesting results.

Most profitably to reduce the susceptibility to hot cracking of high chromium cast iron influenced by the addition of 0.25% Fe-Ti. In breakthroughs dark surfaces were invisible.

The addition of Fe-0.5% Ti improves the hot crack resistance in parts less exposed to defects, ie. the shorter arms. Modification of 0.75% Fe-Ti least favorably influenced the reduction of the tendency to the formation of hot cracks. According to the literature [10-14] titanium improves the strength properties of chromium cast iron, presented studies have demonstrated positive effects of titanium also on tendency to hot cracking.

The research shows that the Althoff-Radtke test can be adapted to determine the tendency for hot cracking for high chromium cast iron. However, it should be noted that the test results can not be compared with results for other alloys.

Acknowledgements

The study was co-financed by NCBiR as a targeted project No. PBS/B5/44/2015.

References

[1] Parkitny, R. & Sczygiol, N. (1987). Rating tendency castings to hot cracking. *Solidification of Metals and Alloys*. 12, 5-28. (in Polish).
 [2] Podrzucki, Cz. (1991). *Cast Iron T I and II*. Cracow: ZG STOP Publication. (in Polish).
 [3] Bałandin, G.F. & Kaszirczew, L.P. (1978). *Litiejnoje Proizvodstvo*, 1, 5.

[4] Röhring, K. & Wolters, D. (1970). *Legiertes Gusseisen T.I. Gusseisen mit Lamellengraphit und karbidisches Gusseisen*. Düsseldorf: Giesserei-Verlag.
 [5] Röhring, K. (1996). *Ni-Hard Material Data and Applications*. Nickel Development Institute.
 [6] Tabrett, C.P., Sare, I.R. & Ghomashchi, M.R. (1996). Microstructure-property relationships in high chromium white iron alloys. *International Materials Reviews*. 41(2), 59-82.
 [7] Bennet, S., Bevries, K. & Williams, M. (1974). Adhesive Fracture Mechanics. *International Journal of Fracture*. 10, 33.
 [8] Drotlew, A. & Garbiak, M. (1998). Cracking behaviour of carbides in erosion wear. *Solidification of Metals and Alloys*. 38, 195-200.
 [9] Jura, S., Cybo, J. & Jura, Z. (2001). Pęknięcia na gorąco odlewów staliwnych problemem ciągle nierozwiązanym. *Archives of Foundry*. 1(2/2), 512-519. (in Polish).
 [10] Qiang, Liu. (2012). *Control of Wear-Resistant Properties in Ti-added Hypereutectic High Chromium Cast Iron*. Sweden: Licentiate Thesis, Royal Institute of Technology, Stockholm.
 [11] Bedolla-Jacuinde, A., Correa, R., Mejía, I., Quezada, J.G. & Rainforth, W.M. (2007). The effect of titanium on the wear behavior of a 16%Cr white cast iron under pure sliding. *Wear*. 263, 808-820.
 [12] Kopyciński, D., Guzik, E., Siekaniec, D. & Szczęsny, A. (2015). The effect of addition of titanium on the structure and properties of High Chromium Cast Iron. *Archives of Foundry Engineering*. 15(3), 35-38.
 [13] Studnicki, A., Dojka, R., Gromczyk, M. & Kondracki, M. (2016). Influence of Titanium on Crystallization and Wear Resistance of High Chromium Cast Iron. *Archives of Foundry Engineering*. 16(1), 117-123.
 [14] Studnicki, A. (2005). Crystallization temperatures of chromium cast iron in function cooling rate. *Archives of Foundry*. 5(48), 371-378 (in Polish).