

# Contemporary Methods of Designing Rail Vehicle Running Systems with the Use of CAD and CAM Solutions

Tomasz ANTKOWIAK<sup>1</sup>, Marcin KRUS<sup>2</sup>

**Summary**

The article discusses the process of designing the running system of a rail vehicle using CAD and CAM tools as the solutions supporting the process. It describes the particular stages of design taking its final shape: from a preliminary design, through a detailed design, ending with the stage of production. Each stage includes a presentation of how CAD and CAM tools are used to support design engineers in their practice.

**Keywords:** running system, design, CAD, CAM

## 1. Introduction

According to the definition, design is “a sequence of unique, complex, and interconnected tasks performed to achieve a common goal, to be carried out within a set time frame, without exceeding the determined budget, in line with the adopted requirements” [1]. Fig. 1 presents the stages of designing contemporary running systems of rail vehicles.

Given the market requirements, many operations involved in the design of running systems, which used to be both resource- and time-consuming, have now been optimised. The construction process has

become easier thanks to CAD (computer-aided design) and CAM (computer-aided manufacturing) solutions.

## 2. Computer-aided design (CAD)

Designing running systems is nowadays supported by CAD software at each stage of design. In the case of the first stage (Fig. 1) – 2D design software makes it possible to:

- adopt preliminary construction specifications for a new design without the need for 3D modelling,

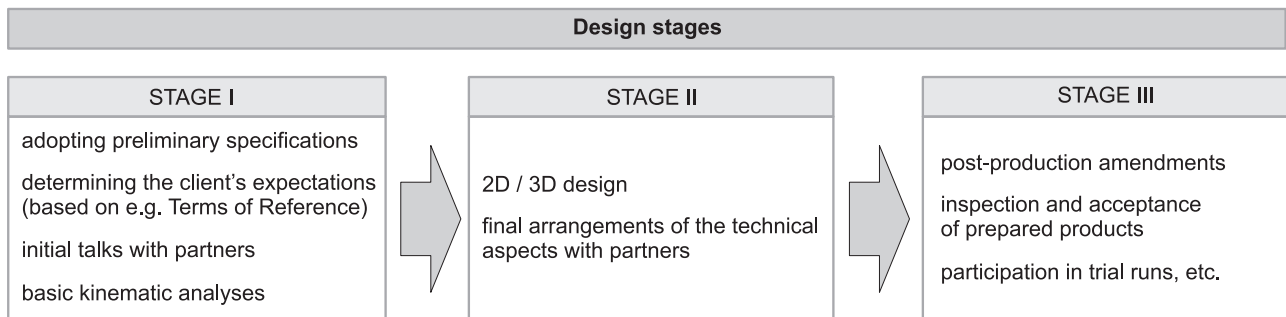

Fig. 1. Stages of designing the running system of a rail vehicle [authors' own work]

<sup>1</sup> M.Sc., Eng.; Łukasiewicz Research Network – TABOR Rail Vehicles Institute, Poznań; e-mail: tomasz.antkowiaktabor.com.pl.

<sup>2</sup> Ph.D. Eng.; Łukasiewicz Research Network – TABOR Rail Vehicles Institute, Poznań; e-mail: marcin.krus@tabor.com.pl.

- perform kinematic analyses to estimate the likelihood of fulfilment of the adopted requirements (Fig. 2) and identify any potential conflicts,
- review the incorporation of elements provided by sub-suppliers (Fig. 3).

The above examples clearly show how the employment of 2D design software can shorten the duration of design development. Given a quick analysis, performed taking various aspects into consideration, it is possible to review structural solutions and eventually approve the design stage in question. In order to proceed to the next stage of design, it is necessary to

approve all the crucial elements of the running systems, i.e.:

- the shape of the bogie frame,
- the drive system together with its sub-assemblies (engine, gearbox, and accessories),
- the primary and secondary type suspension with specific solutions regarding the fine parts provided by sub-suppliers,
- the solution for the transmission of the rim pull,
- the solution for the wheelset axle boxes and steering.

Stage two (Fig. 2) takes place after the approval of the adopted preliminary guidelines. This part of

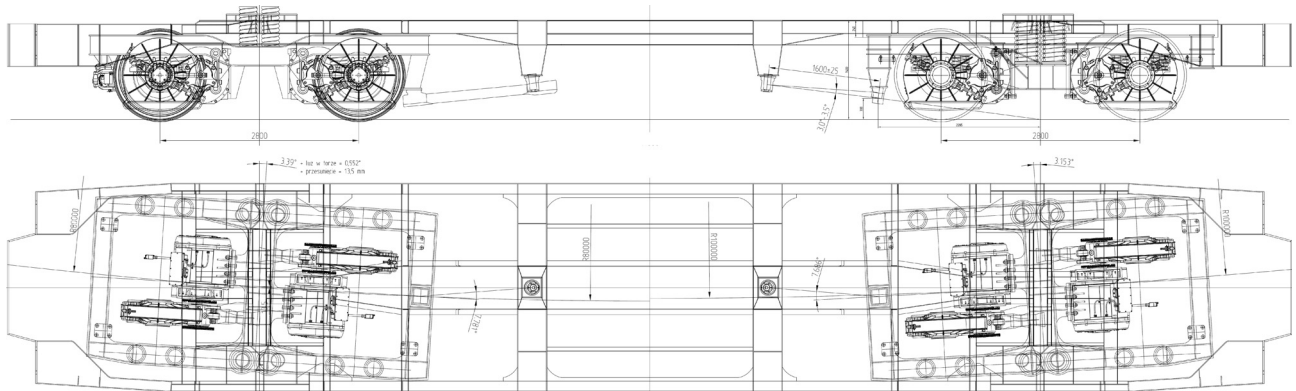

Fig. 2. An example of a 2D analysis performed using 2D design software [own elaboration]

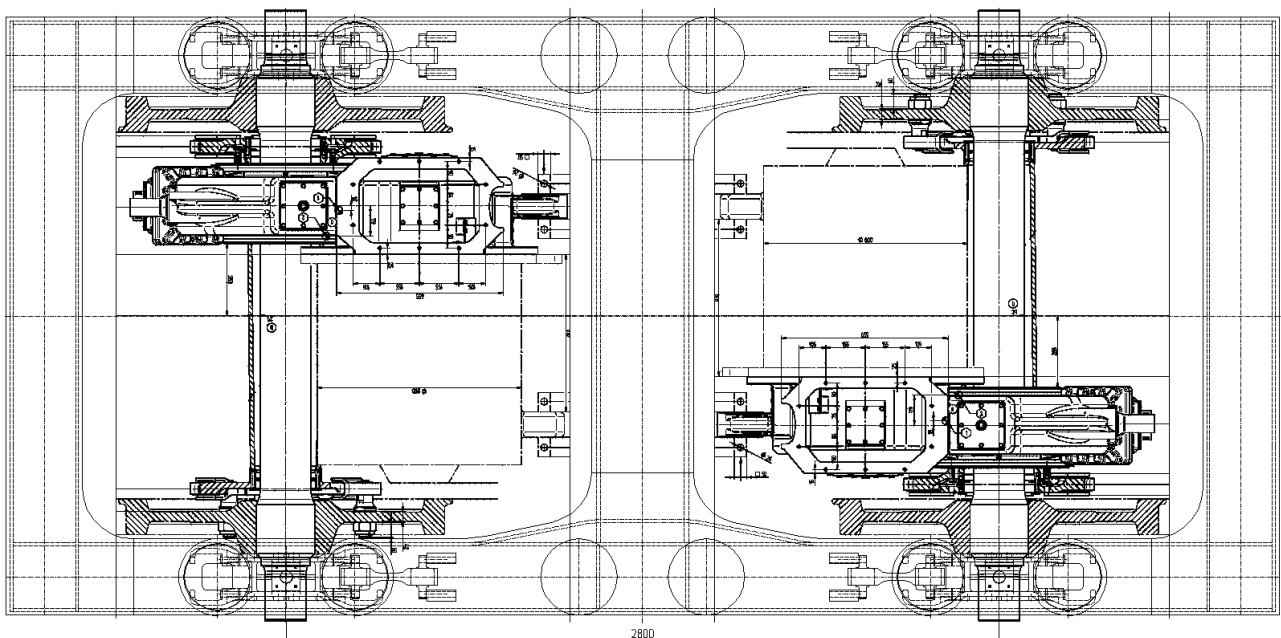

Fig. 3. An example of a review of the development of a drive system using 2D design software [authors' own work]

design involves performing: numerical analyses of elements, such as the bogie frame, the axle box, the wheelset, etc., to review the adopted construction solutions. The analyses mentioned above are performed using software based on the finite element method (FEM) [3]. An example of input data used in the software is given in Table 1.

Table 1

Example of input data used in numerical analysis

Input data
<b>Weight and load</b>
weight of a loaded 4-axle wagon
weight of the body of an empty wagon
tare weight of the bogie
weight of a single wheelset with axle boxes
weight of the bogie frame with accessories
maximum load per wheel
static vertical load on the side bearers
<b>Dimensions</b>
bogie axle spacing
axle box spacing
wheel rolling circle spacing
rolling wheel diameter
side bearer spacing
<b>Suspension</b>
vertical stiffness of the primary suspension
longitudinal stiffness of the primary suspension
lateral stiffness of the primary suspension
<b>Additional parameters</b>
wheel/rail adhesion maximum ratio
wheel/rail adhesion operating ratio
maximum braking deceleration
operating braking deceleration

[Authors' own work].

After the input data is duly processed, load states are adopted. The values of particular loads are determined based on the relations defined in the relevant standards and technical requirements, depending on the analysed element (bogie frame, axle box, wheelset, etc.). The adopted load states are verified based on selected assessment criteria, which can be:

- permissible stress,
- permissible deviation,
- fatigue strength – Goodman diagram (Fig. 4).

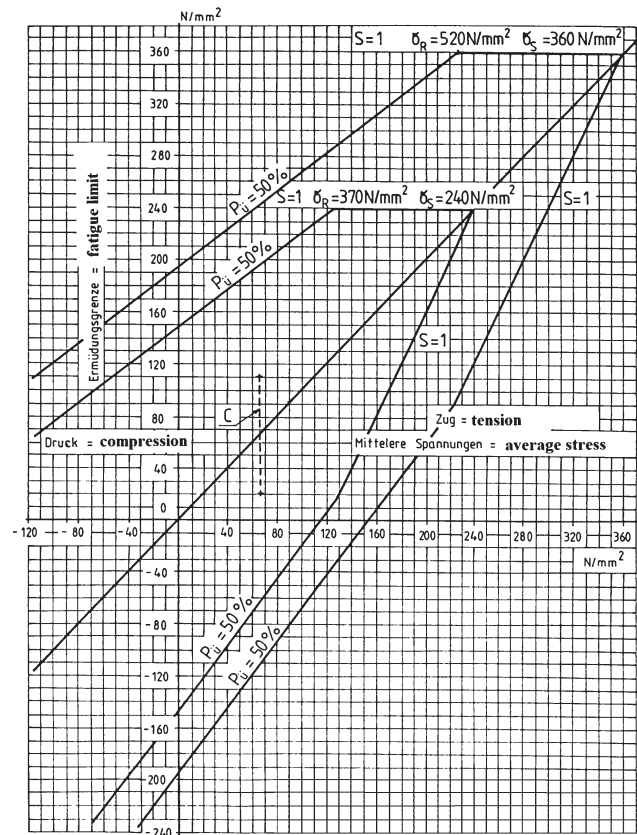

Fig. 4. A Goodman diagram illustrating the fatigue strength for non-welded elements made of S235JR and S355J2 steel [1]:  $P_u$  – survival probability,  $\sigma_R$  – tensile strength,  $\sigma_S$  – yield point

The next step involves deriving a computational model for a given element (Fig. 5a). In the case of symmetrical elements, it is possible to deal with a part thereof, but in the case of non-symmetrical elements, each element needs to be covered as a whole. The computational model takes into account all elements affecting the performance of the chassis and the correct modelling of feeding and receiving the analysed loads. A ready computational model is divided into finite elements (Fig. 5b).

With such compiled data at our disposal, we can proceed with the calculations. An example of calculations for the chassis element – of a running system for a selected load state is shown in Fig. 6.

After all of the adopted load states are considered and all of the set criteria are verified, a post-calculation report is drawn up. This is “feedback” that makes it possible to close the stage of design. Simulation analyses performed to assess the dynamic properties of rail vehicles used within the European network of rails of standard width (nominal value of 1,435 mm) [4]. Simulation models are developed on the basis of the adopted input data. An example of such a model is presented in Fig. 7. The mechanical model of the ana-

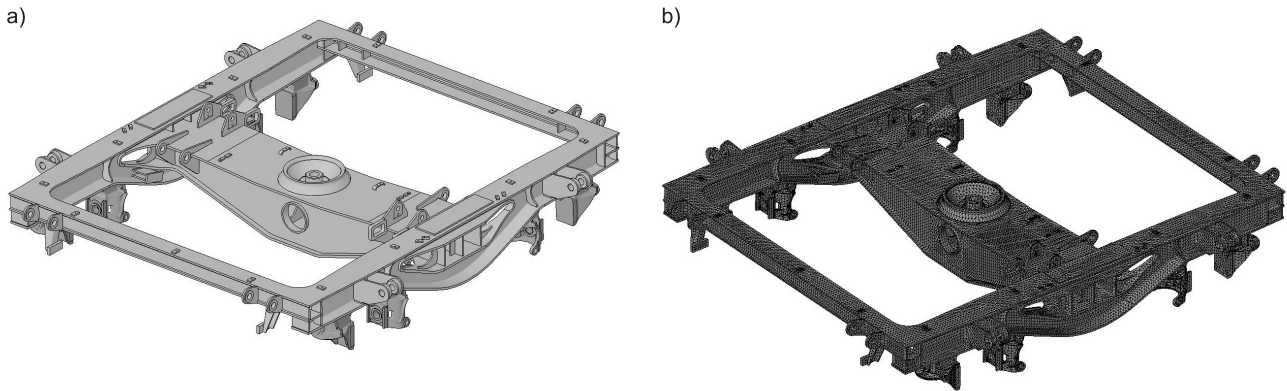

Fig. 5. A computational model of a bogie frame [1]: a) computational model, b) a model divided into finite elements

lysed vehicle is composed of rigid solid elements connected by means of flexible elements and connecting elements making it possible to insert constraints between the solid elements.

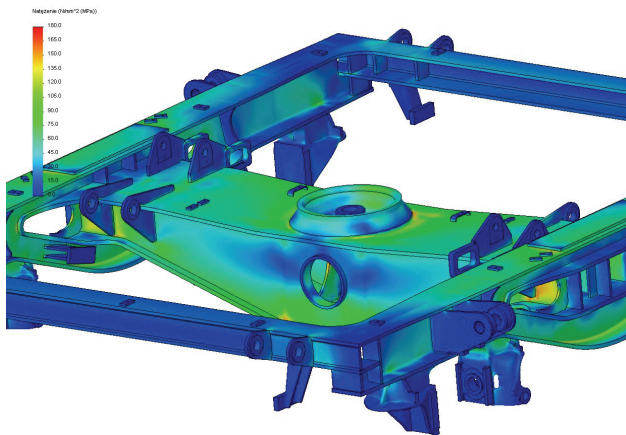

Fig. 6. Distribution of reduced stressed occurring in the bogie frame under the impact of vertical load [1]

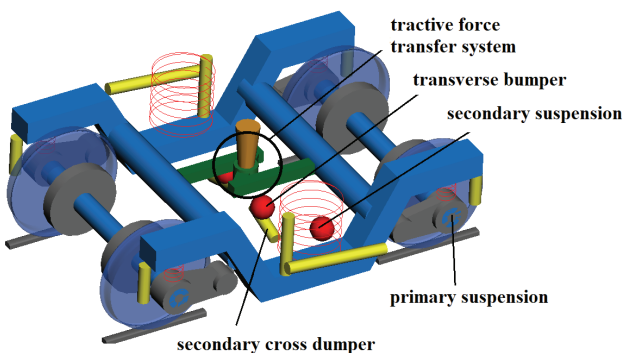

Fig. 7. The computational model adopted in simulation analyses [2]

The next step involves parametrising the values of particular solid elements of the vehicle – together with its connecting elements. It is then necessary to perform a simulation for such boundary conditions adopted in order to check if the model meets the relevant criteria, i.e.:

- safety against derailment on twisted tracks,
- running over a minimum-radius curve,
- roll motion properties,
- linear studies in the fields of: driving safety, track loading, dynamic properties (passage properties).

After simulation analyses are performed, it is necessary to draw up a report which should include the calculation results and the reference criteria. The obtained results make it possible to positively verify the stage of selection of the running system components, such as: springs, hinges, primary and secondary suspension, vibration dampers, etc. and to close the stage of bogie design.

Those stages are followed by stage three, which involves considering the “feedback” from the stage of manufacturing preparations to make the modifications necessary to optimise the manufacturing process. This stage involves making changes to the produced documentation in the scope of:

- base materials – in the event some suggested material is hard to obtain;
- welded parts – if it appears technically difficult to make the necessary welded parts or if it is necessary to optimise the welding process by lowering the quality class of the joints and thus reduce the costs of the process. In such circumstances, the joints are fatigue tested to verify the boundary conditions adopted by the design engineer in the scope of the adopted quality class of joints and safety factors. After such analysis, it is possible to verify and, usually, reduce the costs of manufacture;



- post processing – in the scope of changes of element shapes, work surfaces, etc.

### 3. Computer-aided manufacturing (CAM)

The main purpose of CAM-type software is to create toolpaths (i.e. cut by a milling head, a tool bit, a laser beam, etc.) based on 2D computer drawings or 3D models (these can be both spatial and surface elements). A toolpath means a relative movement of a tool in relation to the processed element – the kinematics of this machine-based process may take different forms. A post-processor translates the paths into control functions the machine is able to recognise and understand. Following the instructions provided in a CNC code makes it possible to manufacture a given element in line with the guidelines.

In the process of designing running systems, thanks to the application of CAD methods, the CAM process has become much more efficient as a result of the application of:

1. 2D design software, where 2D elements can be used directly as the “input” for CNC machine tools – without the need for dimensioning individual elements, which can be a time-consuming and laborious process. An example of such an element is shown in Fig. 8. The software in use at present makes it possible to implement elements directly into CNC<sup>3</sup> machine tools.

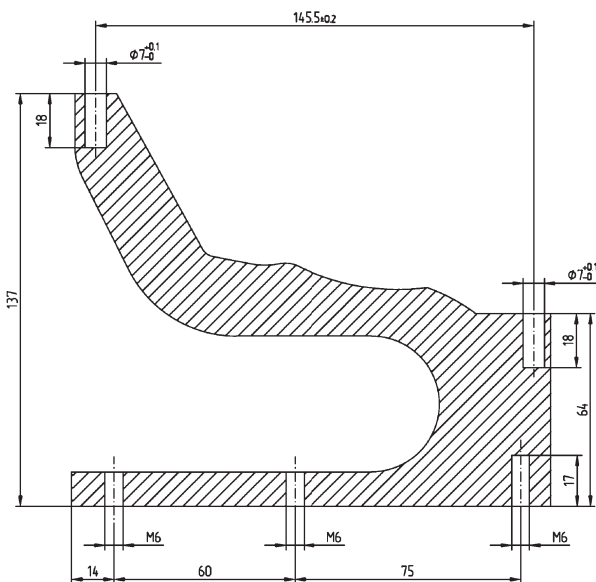

Fig. 8. A fine part designed in 2D software, acting as an “input” for a CNC machine tool [authors’ own work]

2. 3D design software, where 3D elements can be used directly as the “input” for CNC machine tools, e.g. air pipes, control oil lines. Complex 3D elements do not have to come with detailed designs in the form of 2D drawings with dimensions – it is enough to have a correctly implemented file from the 3D design software in use (in a format compatible with a given CNC machine tool) to arrive at a ready product. An example of such a model is shown in Fig. 9.

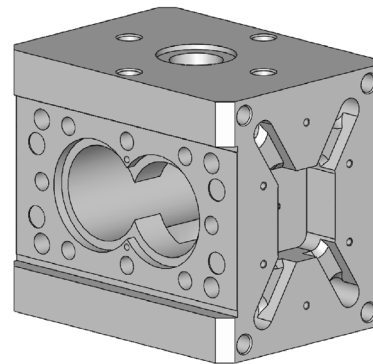

Fig. 9. A fine part designed in 3D software, acting as an “input” for a CNC machine tool [authors’ own work]

### 4. Conclusion

As shown in the article, designing the running systems of rail vehicles is a multi-stage process which involves many complementary factors. The process of design itself follows the cause-and-effect relationship based on feedback from each following stage.

The methods of supporting design engineers in the design process, as presented in the article, contribute greatly to the optimisation of the entire design process in the scope of:

- 1) the duration of the whole process from the moment of commencement until the stage of review and validation,
- 2) the manufacturing costs.

The continuous technological advancement requires design engineers to use increasingly modern tools in the area of computer-aided design and manufacturing in order to make sure that their models are compatible with third-party equipment (CNC machine tools, CNC centres, etc.). The CAD and CAM software in use, in turn, needs to be updated due to the ever-changing requirements regarding the relevant industry standards, regulations, and legislation, etc.

<sup>3</sup> CNC machine – numerically controlled machine tool (Computerized Numerical Control).

## Literature

1. Bryk K.: *Sprawozdanie z oceny bezpieczeństwa ruchu oraz właściwości dynamicznych wagonu osobowego typu 174a o oznaczeniu fabrycznym po modernizacji 111a-10 w oparciu o symulację komputerową* [Report on the assessment of traffic safety and dynamic properties of the type 174a passenger car with factory designation after modernization 111a-10 based on computer simulation], OR11492, Instytut Pojazdów Szynowych TABOR, Poznań, 2018.
2. EN 13749:2011: Railway systems. Wheelsets and bogies. Methods of specifying the structural requirements of bogie frames. 2011.
3. Kuligowski P.: *Sprawozdanie z analizy wytrzymałości ramy wózka 27TNS na tor o szerokości 1668 mm, OR9502* [Report on the analysis of 27TNS bogie frame strength on a 1668 mm wide track], OR9502, Instytut Pojazdów Szynowych TABOR, Poznań, 2009.
4. PN-EN 14363: 2016: Kolejnictwo – Badania i symulacje modelowe właściwości dynamicznych pojazdów przed dopuszczeniem do ruchu, Badania właściwości biegowych i próby stacjonarne [Railway systems. Dynamic properties testing for type approval of railway vehicles. Running properties tests and stationary tests].