

ANALYSIS OF CHATTERING PHENOMENON IN INDUSTRIAL S6-HIGH ROLLING MILL

Maria Cristina VALIGI¹, Susanna PAPINI²

¹ Department of Industrial Engineering, University of Perugia, Italy
E-mail: mariacristina.valigi@unipg.it

² Department of Industrial Engineering, University of Florence, Italy
E-mail: susanna.papini@unifi.it

Abstract

Chatter in rolling mills is the undesirable vibration observed in most of the rolling mills operating at high speed and rolling thin strip. In this work the authors discuss some problems relative to the vibrations occurring in a S6-high cold rolling mill. It can result in not good surface finish for some applications and, rare cases, in gauge variations in the rolled strip and it is considered to be the result of interaction between rolling mill structure and rolling-process. Three basic types of chatter can be classified in rolling mills: torsional, third-octave mode, and fifth-octave-mode chatter.

S6-high rolling mill is an innovative mode to work the steel: it allows the use of very small work rolls laterally guided by individually adjustable side support rolls, which are supported by two rows of roller bearings mounted in cassettes. It has six rolls able to roll steel strip coming directly from hot rolling mill train.

A proposed solution based on empirical observations, vibration analysis and considerations of a model is described with the aim to improve the quality of the product and increasing production.

Keywords: Chatter, vibration analysis, S6-high rolling mill.

1. INTRODUCTION

Due to their excellent features, the S6-high rolling mills are increasingly used for steel strip rolling. The integrated tandem S6-high rolling mill studied in this paper is positioned at the entry section of the annealing and pickling line. Using the integrated treatment line at S6-High, the strip is transported to the processing line, laminated, annealed and pickled in one step thus obtaining a semi-finished product but already laminated, workable again (also on the same line) or marketable. The market share of products perfectly stackable is relevant and the use of this technology offers new scenarios for the steel industry of the future. The attention is focused on the vibrations generated in the rolling mill with the aim to investigate the problem of chatter marks generation. Such marks are regular, parallel marking across the width of strip metal that not only significantly affects the mill performance, but also reduces surface quality of the strip steel. The defects of the strip are the consequence of insurgence of vibrations, generically denominated 'chatter'. Its manifestation is the classical regular, parallel marking across the width of strip metal called "chatter marks" or skid marks [1–5]. There are several types of rolling mill vibration that can have a significant impact on the quality and productivity of the cold rolling process. Under extreme conditions of chatter, strip rupture or damage to the rolling mill can also occur.

Chatter in rolling is considered to be the result of interactions between the mill structure and the rolling

process. The dynamic forces which are generated in the rolling process deflect the structure of the mill, leading to variations in the roll gap, rolls speed, tension, etc. These, in turn, result in further variations in the rolling forces. Self-excited systems begin to vibrate of their own accord spontaneously, the amplitude increasing until some non-linear effect limits any further increase. Chatter is a particular case of self-excited vibrations: the alternating force that sustains the motion is created by the motion itself and stops when the motion stops. Three basic types of rolling chatter have been observed in rolling mills which causes significant chatter bands across the strip and small thickness fluctuations. Torsional chatter, occurs in the 5–25Hz range. Third-octave-mode chatter, which produces large thickness variations and strip rupture, lies in the 125–240Hz range. Fifth-octave-mode chatter occurs in the 500–800Hz range. The third-octave-mode chatter is considered the most critical because it generates large gauge variations in the rolled materials. It therefore has the most detrimental effects in terms of loss productivity due to the lower rolling speeds required to avoid the phenomenon [6-11]. To understand the conditions which lead to the dynamic instability of the rolling process suggests the solutions able to limit the phenomena. Thus, the interaction between the structural dynamics of the mill and the dynamics of the rolling process must be investigated [12-13]. This investigation is often carried out by modelling the rolling mill and the rolling process and their interaction. Figure 1 describes the closed loop diagram

representing schematically the interaction between the structure and the process [14-16].

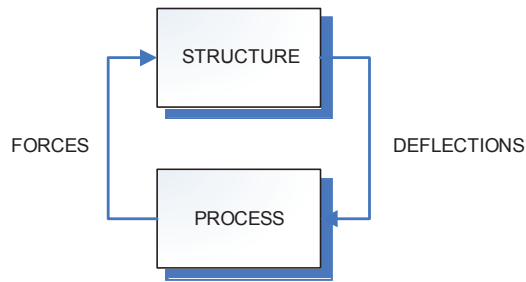

Fig. 1. Diagram scheme

A number of model have been proposed and developed to better understand the rolling process [17].

Unimodal e multimodal structural models have been developed together with models of the rolling process [18-21]. Lumped parameter models have been widely used to represent the mill dynamic [22-26].

1 S6-HIGH ROLLING MILL: CHATTER MARKS AND VIBRATION ANALYSIS

The S6-high cold rolling has six rolls with different diameters arranged horizontally one above each other and symmetrically to the neutral rolling plane. The six rolls are: the work rolls (WRs) the intermediate rolls (IRs), and the backup rolls (BURs). The IRs are the only ones motorized ad transmit the rotation to the stand through gear-boxes linked by means of spindles. In addition there are four cassettes fixed with an additional cylinder called Side Support Roll (SSR). The aim of the SSR is to support the

horizontal load created on the work roll during the process (Figure 2).

The vertical rolling force is transmitted through an hydraulic system that acts on back-up rolls which then transmit the force up to the work rolls. The cassettes have the function to get a rolls packing condition helpful to provide a sufficient compression inside the rolling stand. The two rows of roll bearings have the axis parallel to the side support roll and they have the function to reduce the strokes originated by work rolls during the process. During the rolling process the WR is pushed on SSR because of the horizontal force and transmitted to the roll bearings with the aim to restrain the force. Little fluctuations on the process parameters take to little fluctuations on the forces values so that WR is pushed towards SSR with a vibration mode. When the WR pushes SSR towards its roll bearings with little force, SSR must react to follow the WR contact in order to damp the stroke effects of the following load increasing. This is the important role played by the springs located on the extremities of the SSRs necks into the cassette. The SSRs rolls have a limited grinded life of about some hundreds of rolled strip because they have to resist to the horizontal loads and because they are made with a softer material than the WRs [25-26].

The analyzed plant presents the problem of chatter marks on the strip.

The aim of this paper is to investigate the reason of chatter-marks using a vibration analysis and understand which of parameters is involved in the self-exciting behaviour and how a rolling mill can be adjusted to ensure highest quality and maximum productivity.

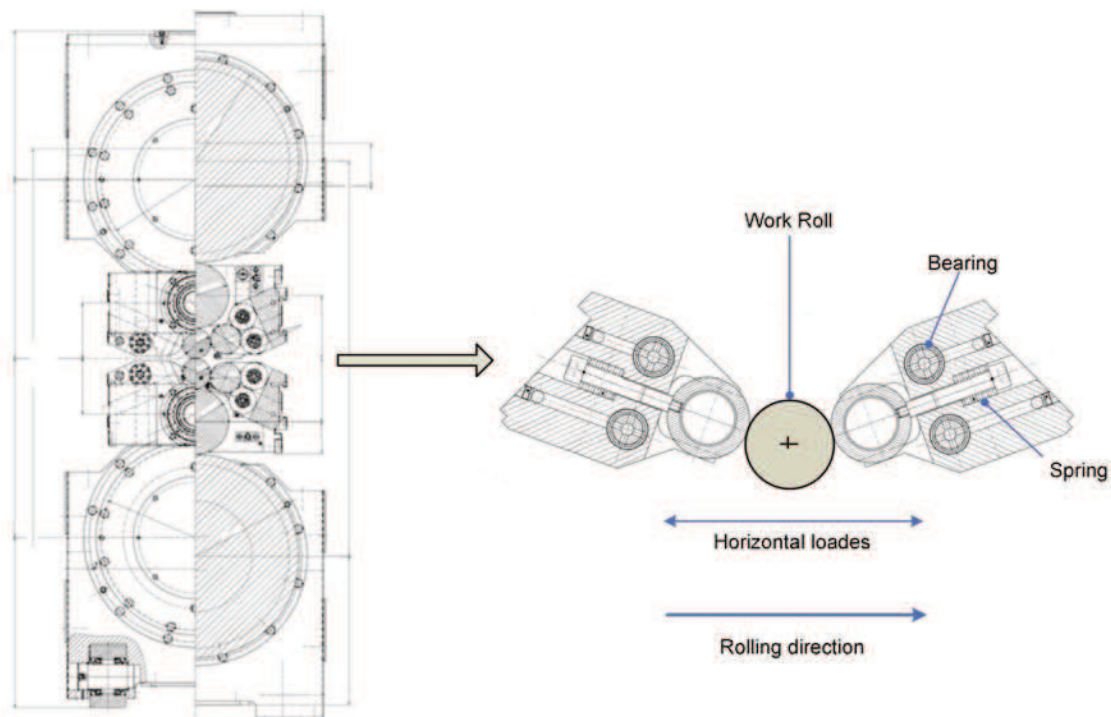

Fig. 2. S6-high rolling mill and side support cassettes

Since the start-up of the plant a series of chatter marks, perpendicular to the rolling direction, compromising the aesthetically quality of the product was noted.

The frequency of the skid marks was about two marks per centimeter so that for a rolling speed of 40 m/min gives a characteristic frequency of about 130 Hz. Because an inaccurate grinding of involved rolls in the process can be a cause of defects a promptly analysis of the grinding process parameters, measurements and inspection reports checks was carried out but results excluded this hypothesis. Experimental evidences showed that the gravity occurrence of chatter marks followed a periodic trend of rolling mill campaigns with to the replacement of SSR cassettes. Particularly chatter marks were noted on SSRs' surfaces the so called facets so that after just 150 km of rolled strip the cassettes had to be replaced. Disappearing the problem with the replacement of the cassettes, the immediate relationship between the age of the SSR rolls and the chatter marks on the strip was deduced. Vibration measurements made directly on the motor gear-box systems and the rolling mill stands for the rolling speeds 40 m/min in order to investigate the origin of chatter.

Since the vibration behavior of the gear-box systems presents a prevalent and admissible component attributable to tooth mesh frequency the gear-box system was left out the possible origin of self-excited vibration.

The vibration measurements made directly on the rolling stand before (in red) and after (in blue) the change of the cassettes, showed a critical value of 124.5 Hz at 40 m/min rolling speed (Figure 3) and 249 Hz at 80 m/min (Figure 4). This results show the origin of the chatter inside the stand and specifically in the cassettes.

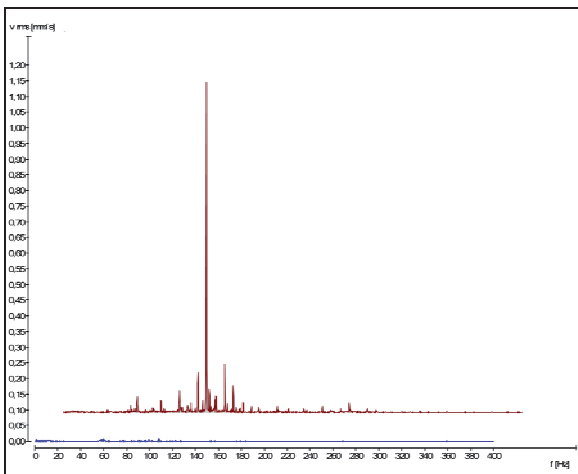

Fig. 3. Measures at 40 m/min

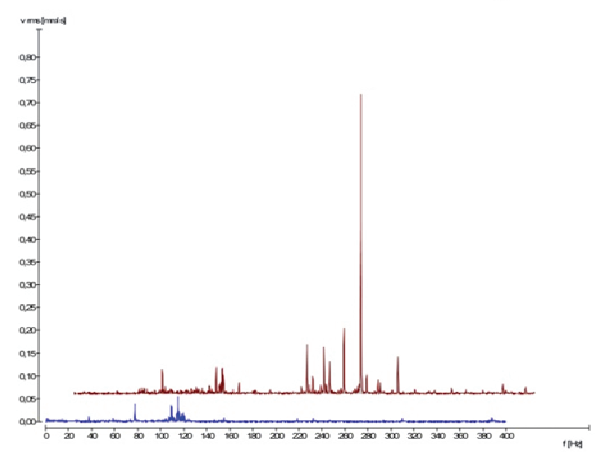

Fig. 4. Measures at 80 m/min

3. PROPOSED MODEL

In order to investigate the influence of individual parameters on the dynamic instability, a lumped parameter model of the rolling mill have been proposed, as the conventional, linear-mass-damping-spring system [21] [24-26]. Firstly a model having ten degree of freedoms (Figure 5-a) where the masses are reduced to the ten rolls involved in the process can be considered but, to simplify the problem, the stand was assumed symmetrical in relation to the rolled strip and symmetrical to the vertical axis of the stand so that the ten degrees of freedoms model was reduced into the simplest system with two degree of freedoms (Figure 5-b).

Equations for the two degree of freedoms model are:

$$\begin{bmatrix} m_1 & 0 \\ 0 & m_2 \end{bmatrix} \begin{Bmatrix} \ddot{y}_1 \\ \ddot{y}_2 \end{Bmatrix} + \begin{bmatrix} c_1 & 0 \\ 0 & 0 \end{bmatrix} \begin{Bmatrix} \dot{y}_1 \\ \dot{y}_2 \end{Bmatrix} + \begin{bmatrix} k_1+k_2 & -k_2 \\ -k_2 & k_2+k_3 \end{bmatrix} \begin{Bmatrix} y_1 \\ y_2 \end{Bmatrix} = \begin{Bmatrix} F \\ 0 \end{Bmatrix} \quad (1)$$

This model takes into account the equivalent mass m_1 of the working rolls, the intermediate rolls and the back-up rolls and the equivalent mass m_2 of the side support rolls.

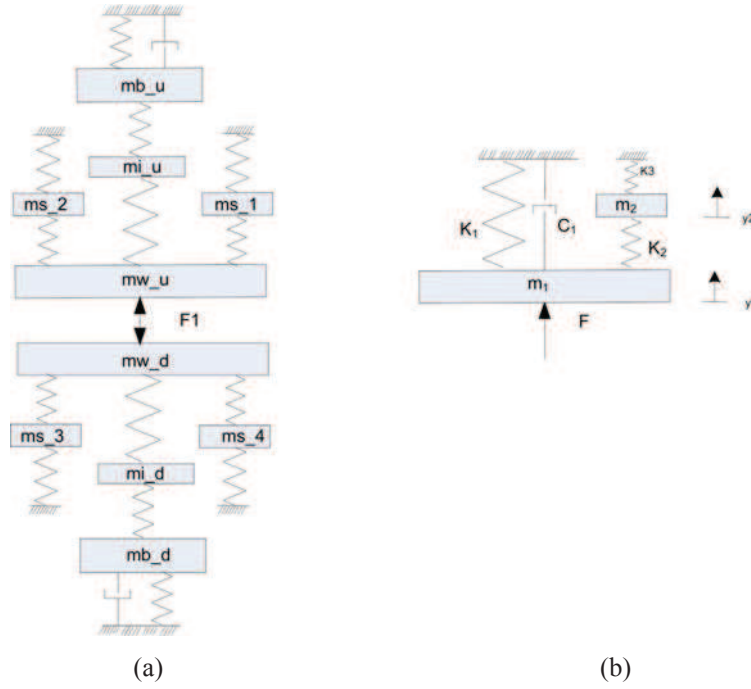

Fig. 5. Lumped parameter model with 10 DOF (a) reduced to a model with 2 DOF (b)

Then k_1 e c_1 represent the stiffness and the damping of the mass frame connection, k_2 the contact stiffness between working rolls and side support rolls, and k_3 is the stiffness of spring in the cassettes. The vertical component F of the rolling force acting between strip and working rolls can be evaluated by a wide used model: the slab theory (Figure 6).

$$dp = 2 \frac{k}{y} dy \pm \frac{\mu P}{y} + 2dk \quad (2)$$

It supposes infinitesimal segments in deformation delimited by two surfaces that remain flat during the process where p is the rolling pressure, μ is the coefficient of friction and k is the mean yield stress in plane strain [1][22]. The model determines the rolling force that, assuming that the roll radius is constant, may be implicitly written as a function of several variables :

$$F = F(y_e, y_d, \sigma_{xe}, \sigma_{xd}, \mu, \lambda) \quad (3)$$

where y_e , y_d , are the half thickness of rolled strip at the entry and at the exit of the stand, σ_{xe} , σ_{xd} , are the horizontal tensile stress at entry and at exit of the stand and λ is the resistance to deformation dependent on strain hardening characteristics [23-25].

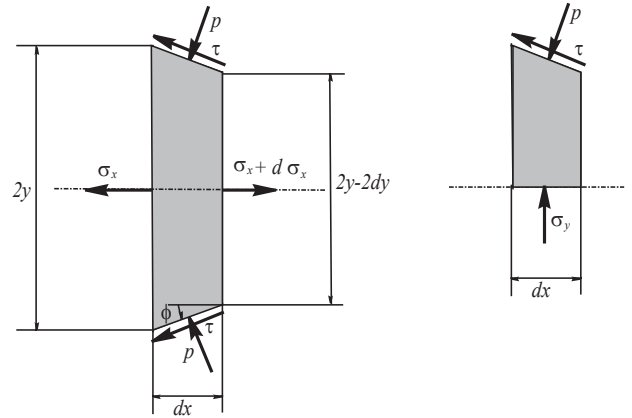

Fig. 6. Slab analysis

4. PROPOSED SOLUTION

The disturbances and the variations of the strip thickness due to roll vibration generate the dynamic component of the rolling force. This dynamic component deflects the structure of the mill leading to variations in the roll gap, y_1 , which in turn result in further variations in the rolling force. Under certain conditions, however, this interaction between the structure and process leads to dynamic instability. By applying the Laplace transform to the above equations (1), the following relationships are obtained:

$$\begin{cases} \frac{L[y_1]}{L[F]} = G1(s) = \frac{(m_2 s^2 + k_{sw} + k_s)}{(m_1 s^2 + c_0 s + k_0 + k_{sw})(m_2 s^2 + k_{sw} + k_s) - k_{sw}} \\ \frac{L[y_2]}{L[F]} = G2(s) = \frac{k_{sw}}{(m_2 s^2 + k_{sw} + k_s)} \frac{(m_2 s^2 + k_{sw} + k_s)}{(m_1 s^2 + c_0 s + k_0 + k_{sw})(m_2 s^2 + k_{sw} + k_s) - k_{sw}} \end{cases} \quad (4)$$

On the basis of the model a proposed solution for improve the productivity of the plant is the change of spring stiffness in the cassettes in order to have an anti-resonance at 124 Hz. Figure 7 shows the diagrams of $G1(s)$ with two different values of k_s : the red line regards the system with the current value of 260 N/mm and the blue one with the proposed value of 485 N/mm. Immediately after replacing the springs the presence of skid marks appeared after 350 km of rolled strip so that the proposed solution has resulted in doubling of the side support rolls life [25-26].

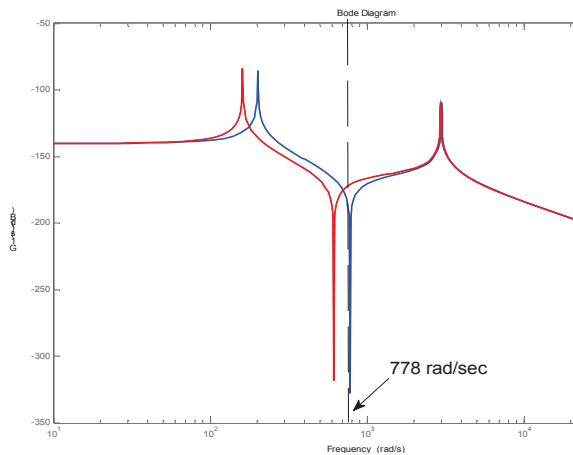

Fig. 7. Frequency response $G1(s)$: the blue line with the proposed value of k_s the red line with the current value of k_s

5. CONCLUSION

In this work the source of the chatter in a rolling mill was identified in side support rolls so that a proposed solution based on a linearized two degrees of freedoms model has improved the mill performances. This just the beginning of the study of chatter problem in the analyzed plant; the authors are going to investigate the phenomenon with a more complex models using non-linear models in closed loop and considering more refined model of the process (e.g. the Orowan's model) with the aim to analyze the problem and further increase the productivity of the mill.

Acknowledgements

This work is a result of collaboration between the Acciai Speciali Terni Spa and University of Perugia. The authors desire to thank the competent consultant team of A.S.T. in particular the engineers S. Cervo and A. Petrucci. Furthermore a special thanks to Prof. Paolo Toni for the careful supervision at the activity.

References

- [1] L. Chefneux, J.-P. Fischbach, J. Gouzou, *Study and control of chatter in cold rolling*. (1980) Iron and Steel Engineer 17–26.
- [2] R.-M. Guo, A. C. Urso. *Analysis of chatter vibration phenomena of rolling mills using finite element method*. (1993) Iron and Steel Engineer Jan. 29–39.
- [3] D. L. Paton, S. Critchley. *Tandem mill vibration: its cause and control*. (1985) Iron and Steel Making 37–43.
- [4] I. S. Yun, W. R. D. Wilson, K. F. Ehmann. *Review of chatter studies in cold rolling*. International (1998) Journal of Machine Tools & Manufacture 38 1499–1530.
- [5] W. L. Roberts. *Four-h mill-stand chatter of the fifth octave mode*. (1978) Iron Steel Engineering, 55, 41-47.
- [6] Evans, P. R., Hill, D. E., and Vaughan, N. D. *Dynamic Characteristics of a Rolling Mill*. (1996), Proc. Instn. Mech. Engrs., V210 259-271.
- [7] J. Tlustý, G. Chandra, S. Critchley, D. Paton, *Chatter in cold rolling*. (1982) Annals of the CIRP, 31, 195.
- [8] M. Malvezzi, M. Rinchi. *Control systems of strip tension in hot steel rolling mills trains*. Proceedings of Nineteenth IASTED International Conference -MIC 2000 - Modelling, Identification and Control, Innsbruck, Austria, February 14-17, 2000.
- [9] M. Rinchi; A. Rindi. *Fenomeni vibratori autoeccitati nei laminatoi finitori*. In: XIV Congresso Nazionale AIMETA, Como, 6-9 ottobre 1999.
- [10] Pei-Hua Hu Huyue Zhao K F Ehmann. *Third-octave-mode chatter in rolling. Part 1: Chatter model*. (2006), Proceedings of the Institution of Mechanical Engineers, Part B: Journal of Engineering Manufacture August 1, 220: 1267-1277.
- [11] Y Chen, S Liu, T Shi, S. Yang, G. Liao. *Stability analysis of the rolling process and regenerative chatter on 2030 tandem mills*. (2002) Imech Part C: J Mechanical Engineering Science, 216 1225-1235.
- [12] D. R. Bland, H. Ford. *The calculation of roll force and torque in cold strip rolling with tensions*. (1948) Proceedings of the Institute of Mechanical Engineers 159 144–163.
- [13] I. S. Yun, W. R. D. Wilson, K. F. Ehmann. *Review of chatter studies in cold rolling*. (1998) International Journal of Machine Tools & Manufacture 38 1499–1530.
- [14] J. M. Alexander. *On the theory of rolling*. Proceedings of the Royal Society of London A326 (1972) 535–563.
- [15] T. Tamiya, K. Furui, H. Hida. *Analysis of chattering phenomenon in cold rolling*. (1980) Proceedings of International Conference on Steel Rolling, 2, 1191-1207.

- [16] G. L. Nessler, J. F. Cory, "Identification of chatter sources in cold rolling mills", (1993), *Iron and steel Engineer*, 40-45.
- [17] P.-H. Hu, K. F. Ehm. *A dynamic model of the rolling process. Part I: homogeneous model.* (2000) *International Journal of Machine Tools & Manufacture* ,40, 1–19.
- [18] I. Yarita, K. Furukawa, Y. Seino. *An analysis of chattering in cold rolling of ultrathin gauge steel strip.* (1978) *Transactions ISIJ* 19 (1) 1–10.
- [19] K. Misonoh. *Analysis of chattering in cold rolling of steel strip.* (1980) *Journal of the JSTP* 21 (238) 1006–1010.
- [20] R. Venter, A. Abd-Rabbo, "Modelling of the rolling process—part I", (1980), *International Journal of Mechanical Science* 22 , 83–92.
- [21] A. Swiatonoswki, A. Bar. *Parametrical Excitement vibration in tandem mills-mathematical model and its analysis.* (2003) *Journal of material processing Technology* 134 214-224.
- [22] Malvezzi M, Valigi M. C., (2008) "Cold rolling mill process: A numerical procedure for industrial applications. *Meccanica* 43 (1) 1-9
- [23] Johnson, R. E., and Qi, Q. *Chatter Dynamics in Sheet Rolling,*" (1994) *Int. J. Mech. Sci.*, 36(7). pp. 617–30.
- [24] Gryllias, K. C. , Antoniadis, I. A. *Modeling and experimental analysis of a 6-High industrial rolling mill vibration response.* in Proc. The Seventh International Conference on Condition Monitoring and Machinery Failure Prevention Technologies, Ettington Chase, Stratford-upon-Avon, England June ,22-24,(2010).
- [25] Valigi, M. C., Cervo, S., Petrucci, A. *Chatter Marks and Vibration Analysis in a S6-high cold rolling mill.* in Proc. III Inter. Conference on Condition Monitoring of Machinery in Non-Stationary Operations (CMMN02013), Ferrara ,Italy, May,8-10,(2013).
- [26] Valigi, M. C., Papini S. *Chatter in a S6-high rolling mill.* XXI Congresso AIMETA, Torino, Italy, 17-20 Settembre (2013).